

Distributed by:

JAMECO[®]
ELECTRONICS

www.Jameco.com ♦ 1-800-831-4242

The content and copyrights of the attached
material are the property of its owner.

Jameco Part Number 741335

FEATURES AND SPECIFICATIONS

Features and Benefits

- Blind mating panel mount receptacle
- For wire-to-wire and wire-to-board applications
- Fully isolated terminals to protect contacts from damage
- Uses standard Mini-Fit series terminals

Reference Information

Product Specification: PS-5556-0002

Packaging: Tray and bag

UL File No.: E29179

CSA File No.: LR19980

TUV License No.: R75142

Mates With: [42404](#), [42440](#), [43759](#), [43810](#), [43879](#), [44068](#) and [44474](#) headers or [42475](#) and [43770](#) plugs

Use With: [5556](#) or [44476](#) HCS terminals

Designed In: Millimeters

Electrical

Current: (Used with 16 AWG)

Circuits	2-3	4-6	7-10	12-24
Amperes-BMI	9	8	7	6
Amperes-BMI with HCS	12	11	10	9

Mechanical

Contact Insertion Force: 1.5kg max.

Contact Retention to Housing: 3.0kg min.

Wire Pull-Out Force: 9.0kg min.

Mating Force: 0.7kg (1.54 lb) max.

Unmating Force: 0.35kg (0.7 lb) min.

Normal Force: 200g min.

Durability: 30 cycles

Physical

Housing: 6/6 nylon, UL 94V-2 or 94V-0

Contact: Brass or Phosphor Bronze

Plating: Tin, select Gold or overall Gold

Operating Temperature: -40 to +105°C



4.20mm (.165") Pitch Mini-Fit, BMI™ Receptacle

42474/43760

Dual Row With Panel Mount Ears

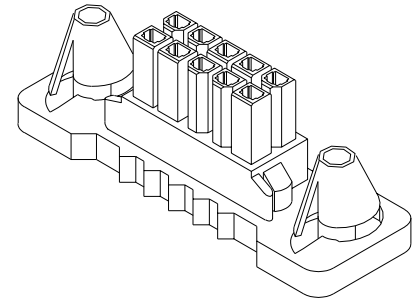

Power Connectors

F

CATALOG DRAWING (FOR REFERENCE ONLY)

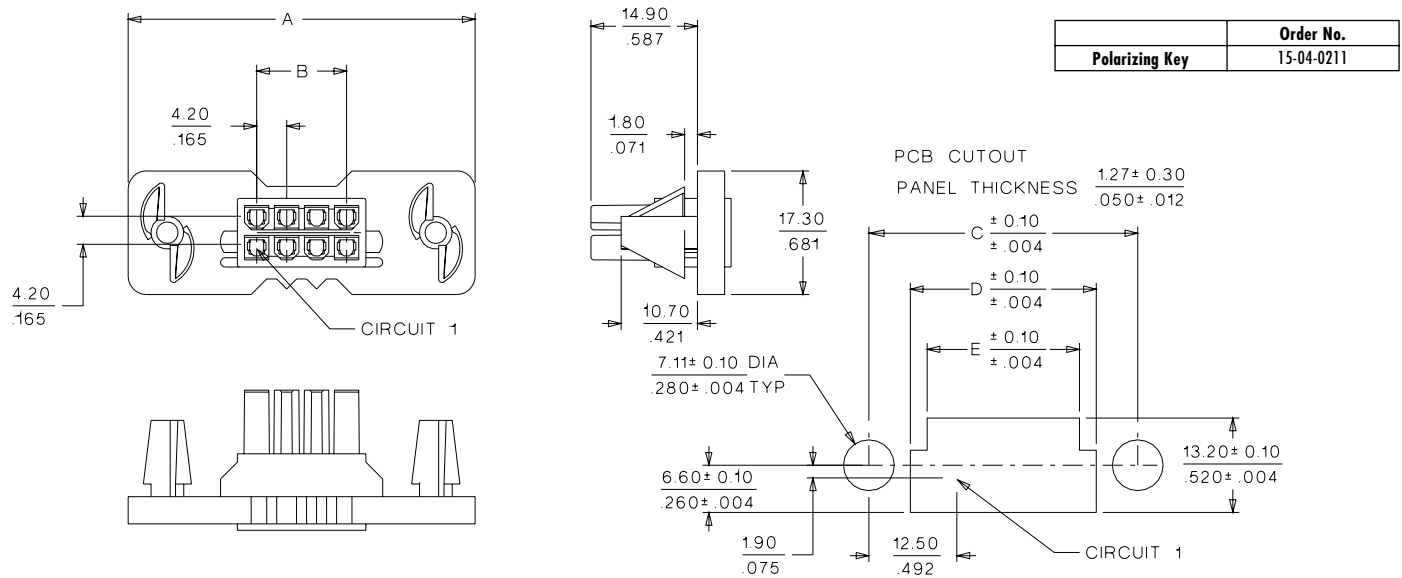

ORDERING INFORMATION AND DIMENSIONS

Circuits	Order No.		Dimension				
	94V-2	94V-0	A	B	C	D	E
4	• 15-06-0040	• 15-06-0041	40.20 (1.583)	4.20 (.165)	29.20 (1.150)	17.60 (.693)	12.90 (.508)
6	• 15-06-0060	• 15-06-0061	44.40 (1.748)	8.40 (.331)	33.40 (1.315)	21.80 (.858)	17.10 (.673)
8	• 15-06-0080		48.60 (1.913)	12.60 (.496)	37.60 (1.480)	26.00 (1.023)	21.30 (.838)
10	• 15-06-0100	• 15-06-0101	52.80 (2.078)	16.80 (.661)	41.80 (1.645)	30.20 (1.189)	25.50 (1.004)
14	• 15-06-0140	• 15-06-0141	61.20 (2.409)	25.20 (.992)	50.20 (1.976)	38.60 (1.520)	33.90 (1.335)
18	• 15-06-0180	• 15-06-0181	69.60 (2.740)	33.60 (1.323)	58.60 (2.307)	47.00 (1.850)	42.30 (1.665)
24	• 15-06-0240	• 15-06-0241	82.20 (3.236)	46.20 (1.819)	71.20 (2.803)	59.60 (2.346)	54.90 (2.161)
36	43760-0001		107.40 (4.228)	71.40 (2.811)	96.40 (3.795)	81.50 (3.208)	76.78 (3.023)

• US Standard Product, available through Molex franchised distributors



PRODUCT SPECIFICATION

MINI-FIT HCS (High Current System)

1.0 SCOPE

This Product Specification covers performance requirements for the MINI-FIT HCS 4.20 mm (.165 inch) centerline (pitch) printed circuit board (PCB) connector series with Tin or Gold plating, and The MINI-FIT HCS connector series terminated with 16 to 28 AWG wire using Crimp technology with Tin or Gold plating.

2.0 PRODUCT DESCRIPTION

2.1 PRODUCT NAME AND SERIES NUMBER (S)

<u>PRODUCT NAME</u>	<u>PART NUMBER</u>
Female Crimp Terminal (Mini-Fit HCS)	44476-****
Male Crimp Terminal (Mini-Fit HCS)	44478-****
Receptacle Housing (Mini-Fit Jr.)	5557-****
Receptacle Housing (Mini-Fit PTA)	30067-****
Receptacle Housing (Mini-Fit BMI)	42474-****
Receptacle Header Assembly (Mini-Fit BMI)	44475-****
Plug Housing (Mini-Fit Jr.)	5559-****
Plug Housing (Mini-Fit TPA)	30068-****
Plug Housing (Mini-Fit BMI)	42475-****
Vertical Header Assembly (Mini-Fit HCS)	44472-****
Vertical Header Assembly (Mini-Fit TPA)	44473-****
Vertical Header Assembly (Mini-Fit (BMI)	44474-****
Vertical Header Assembly (Mini-Fit SMC)	44068-****
Right Angle Header Assembly (Mini-Fit Jr.)	5569-****
Right Angle Header Assembly (Mini-Fit TPA)	30070-****
Right Angle Header Assembly (Mini-Fit BMI)	42404-****
Right Angle Header Assembly (Mini-Fit SMC)	43810-****

Mating the Mini-Fit receptacles to Mini-Fit plugs or Mini-Fit headers using 44476 or 44478 terminals allow it to qualify as a Mini-Fit HCS system.

2.2 DIMENSIONS, MATERIALS, PLATINGS AND MARKINGS

See the appropriate sales drawings for the information on dimensions, materials, platings and markings.

2.3 SAFETY AGENCY APPROVALS

UL File #E29179
CSA Certificate #LR 19980
TUV Certificate #R75142-8

3.0 APPLICABLE DOCUMENTS AND SPECIFICATIONS

See sales drawings and the other sections of this specification for the necessary referenced documents and specifications

REVISION: D	ECR/ECN INFORMATION: <u>EC No:</u> UCP2003-2604 <u>DATE:</u> 2003 / 06 / 12	TITLE: PRODUCT SPECIFICATION FOR MINI-FIT HCS CONNECTOR SYSTEM	SHEET No. 1 of 5
DOCUMENT NUMBER: PS-44476-001	CREATED / REVISED BY: C.STEWART	CHECKED BY: Y. MARGULIS	APPROVED BY: Y. MARGULIS



PRODUCT SPECIFICATION

NGS

4.1 VOLTAGE

600 Volts AC (RMS) (or 600 Volts DC)

4.2 CURRENT AND APPLICABLE WIRES

Maximum Insulation Diameter and Applicable Wire Gauges	16 AWG: 3.10/. 122 MAXIMUM			
	18-24 AWG: 3.10/. 122 MAXIMUM			
MAXIMUM CURRENT RATING (Amperes)				
Ckt. Size Wire	2 & 3	4 - 6	7 - 10	12 - 24
AWG #16	12	11	10	9
AWG #18	12	11	10	9
AWG #20	9	9	8	8

4.3 TEMPERATURE

Operating: * - 40°C to + 105°C

Nonoperating: - 40°C to + 105°C

**Including 30°C terminal temperature at rated current*

4.0 PERFORMANCE

5.1 ELECTRICAL REQUIREMENTS

ITEM	DESCRIPTION	TEST CONDITION	REQUIREMENT
1	Contact Resistance (Low Level)	Mate connectors: apply a maximum voltage of 20 mV and a current of 100 mA. Wire resistance shall be removed from the measured value.	10 milliohms MAXIMUM [initial]
2	Contact Resistance @ Rated Current	Mate connectors: apply a maximum voltage of 20 mV at rated current.	10 milliohms MAXIMUM [initial]
3	Contact Resistance of Wire Termination (Low Level)	Terminate the applicable wire to the terminal and measure wire using a voltage of 20 mV and a current of 100 mA.	5 milliohms MAXIMUM [initial]

REVISION:	ECR/ECN INFORMATION:	TITLE:	SHEET No.
D	EC No: UCP2003-2604 DATE: 2003 / 06 / 12	PRODUCT SPECIFICATION FOR MINI-FIT HCS CONNECTOR SYSTEM	2 of 5
DOCUMENT NUMBER:	CREATED / REVISED BY:	CHECKED BY:	APPROVED BY:
PS-44476-001	C.STEWART	Y. MARGULIS	Y. MARGULIS



PRODUCT SPECIFICATION

4	Insulation Resistance	Mate connectors: apply a voltage of 500 VDC between adjacent terminals and between terminals to ground.	1000 Megohms MINIMUM
----------	------------------------------	---	-------------------------

5.1 ELECTRICAL REQUIREMENTS (continued)

ITEM	DESCRIPTION	TEST CONDITION	REQUIREMENT
5	Dielectric Withstanding Voltage	Mate connectors: apply a voltage of 1500 VAC for 1 minute between adjacent terminals and between terminals to ground.	No breakdown. Current leakage < 5 mA
6	Temperature Rise (via Current Cycling)	Mate connectors. Measure the temperature rise at the rated current after 96 hours, during current cycling (45 minutes ON and 15 minutes OFF per hour) for 240 hours, and after final 96-hour steady state.	Temperature rise: +30°C MAXIMUM

5.2 MECHANICAL REQUIREMENTS

ITEM	DESCRIPTION	TEST CONDITION	REQUIREMENT
1	Terminal Mate and Unmate Forces	Insert and withdraw terminal (male to female) at a rate of 25 ± 6 mm (1 ± ¼ inch) per minute.	14.7 N (3.30 lbf) MAXIMUM insertion force & 1.0 N (0.02 lbf) MINIMUM withdrawal force
2	Terminal Retention Force (in Housing)	Axial pullout force on the terminal in the housing at a rate of 25 ± 6 mm (1 ± ¼ inch) per minute.	30 N (6.74 lbf) MINIMUM retention force
3	Durability	Mate connectors up to 30 cycles at a maximum rate of 10 cycles per minute prior to Environmental Tests.	20 milliohms MAXIMUM
4	Vibration (Random)	Mate connectors and vibrate per EIA 364-28, test condition VII.	10 milliohms MAXIMUM (change from initial) & Discontinuity < 1 microsecond
5	Shock (Mechanical)	Mate connectors and shock at 50 g's with ½ sine wave (11 milliseconds) shocks in the ±X, ±Y, ±Z axes, (18 shocks total).	20 milliohms MAXIMUM & Discontinuity < 1 microsecond

<u>REVISION:</u> D	<u>ECR/ECN INFORMATION:</u> <u>EC No:</u> UCP2003-2604 <u>DATE:</u> 2003 / 06 / 12	<u>TITLE:</u> PRODUCT SPECIFICATION FOR MINI-FIT HCS CONNECTOR SYSTEM	<u>SHEET No.</u> 3 of 5
<u>DOCUMENT NUMBER:</u> PS-44476-001		<u>CREATED / REVISED BY:</u> C.STEWART	<u>CHECKED BY:</u> Y. MARGULIS
		<u>APPROVED BY:</u> Y. MARGULIS	



PRODUCT SPECIFICATION

6	Wire Pullout Force (Axial)	Apply an axial pullout force on the wire at a rate of 25 ± 6 mm (1 ± ¼ inch).	16 Awg = 88.0 N (19.8 lbf) Min. 18 Awg = 88.0 N (19.8 lbf) Min. 20 Awg = 59.0 N (13.3 lbf) Min. 22 Awg = 39.0 N (8.78 lbf) Min. 24 Awg = 29.0 N (6.52 lbf) Min. 26 Awg = 19.0 N (4.27 lbf) Min. 28 Awg = 9.80 N (2.20 lbf) Min.
----------	-----------------------------------	---	---

5.2 MECHANICAL REQUIREMENTS (continued)

7	Terminal Insertion Force (into Housing)	Apply an axial insertion force on the terminal at a rate of 25 ± 6 mm (1 ± ¼ inch).	15.0 N (3.37 lbf) MAXIMUM insertion force
8	Normal Force	Apply a perpendicular force.	0.49 N (50 grams) MINIMUM [Gold (noble) plating] OR 1.47 N (150 grams) MINIMUM [Tin (non-noble) plating]
9	PCB Engagement and Separation Forces	Engage and separate a connector at a rate of 25 ± 6 mm (1 ± ¼ inch) per minute.	49.0 N (11.0 lbf) MAXIMUM insertion force & 10.0 N (2.24 lbf) MINIMUM withdrawal force
10	Panel Insertion and Withdrawal Forces	Insert and withdraw a connector at a rate of 25 ± 6 mm (1 ± ¼ inch) per minute.	225 N (50.7 lbf) MAXIMUM insertion force & 157 N (35.3 lbf) MINIMUM withdrawal force

5.3 ENVIRONMENTAL REQUIREMENTS

ITEM	DESCRIPTION	TEST CONDITION	REQUIREMENT
1	Thermal Shock	Mate connectors: expose for 5 cycles between temperatures -55 and 105°C; dwell 0.5 hours at each temperature.	20 milliohms MAXIMUM Visual: No Damage Dielectric Strength per 5.1.5 Insulation Resistance per 5.1.4
2	Thermal Aging	Mate connectors; expose to: 96 hours at 105 ± 2°C	20 milliohms MAXIMUM & Visual: No Damage
3	Humidity (Steady State)	Mate connectors: expose to a temperature of 60 ± 2°C with a relative humidity of 90-95% for 96 hours.	20 milliohms MAXIMUM Dielectric Strength per 5.1.5 Insulation Resistance per 5.1.4 Visual: No Damage

<u>REVISION:</u> D	<u>ECR/ECN INFORMATION:</u> <u>EC No:</u> UCP2003-2604 <u>DATE:</u> 2003 / 06 / 12	<u>TITLE:</u>	PRODUCT SPECIFICATION FOR MINI-FIT HCS CONNECTOR SYSTEM	<u>SHEET No.</u> 4 of 5
<u>DOCUMENT NUMBER:</u> PS-44476-001		<u>CREATED / REVISED BY:</u> C.STEWART	<u>CHECKED BY:</u> Y. MARGULIS	<u>APPROVED BY:</u> Y. MARGULIS



PRODUCT SPECIFICATION

4	Solderability	Per SMES-152	Solder coverage: 95% MINIMUM (per SMES-152)
5	Solder Resistance	Dip connector terminal tails in solder: Solder Duration: 5 ± 0.5 seconds; Solder Temperature: 235 ± 5°C	Visual: No Damage to insulator material

5.3 ENVIRONMENTAL REQUIREMENTS (continued)

ITEM	DESCRIPTION	TEST CONDITION	REQUIREMENT
6	Cold Resistance	Mate connectors: Duration: 96 hours; Temperature: -40 ± 3°C	20 milliohms MAXIMUM Visual: No Damage
7	Corrosive Atmosphere: Sulfur Dioxide Gas (SO₂)	Mate connectors: Duration: 24 hours exposure. Atmosphere: 50 parts per million (ppm) SO ₂ Gas. Temperature: 40 ± 3°C	20 milliohms MAXIMUM Visual: No damage

5.0 PACKAGING

Parts shall be packaged to protect against damage during handling, transit and storage.

REVISION: D	ECR/ECN INFORMATION: EC No: UCP2003-2604 DATE: 2003 / 06 / 12	TITLE: PRODUCT SPECIFICATION FOR MINI-FIT HCS CONNECTOR SYSTEM	SHEET No. 5 of 5
DOCUMENT NUMBER: PS-44476-001	CREATED / REVISED BY: C.STEWART	CHECKED BY: Y. MARGULIS	APPROVED BY: Y. MARGULIS

20 19 18 17 16 15 14 13 12 11 10 9 8 7 6 5 4 3 2 1

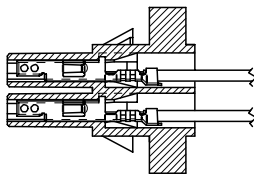

SECTION "A-A"
TERMINAL ORIENTATION

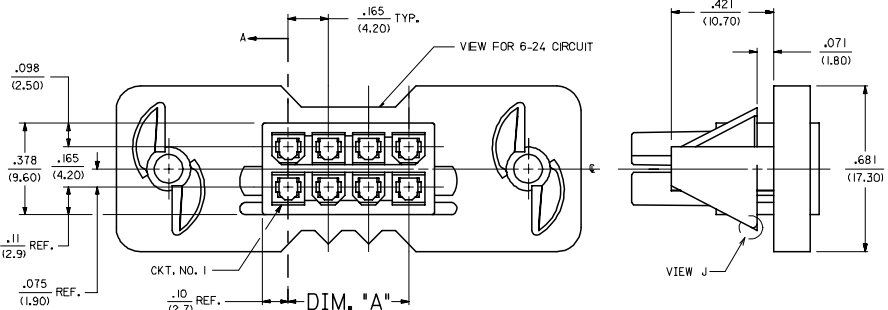

THIS AREA CAN BE SHARP TO .025/(0.64) MAXIMUM RADIUS

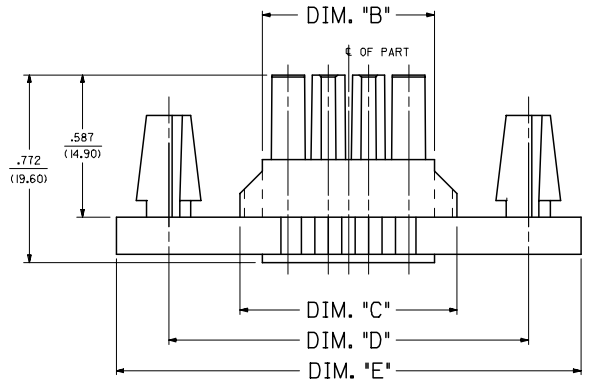

2-8 & 12-24 CIRCUIT HEADER
(SEE SHEET 2 FOR 10 CIRCUIT HEADER DESIGN)

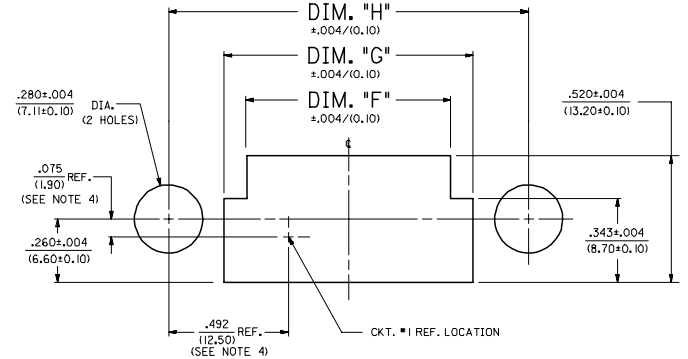

RECOMMENDED PANEL CUT-OUT FOR .050±0.02/(1.27±0.30) THICK PANEL
(SEE NOTE 11)

CKT. SIZE	DIM. "A"	DIM. "B"	DIM. "C"	DIM. "D"	DIM. "E"	DIM. "F"	DIM. "G"	DIM. "H"
2	N/A	.213 (5.40)	.398 (10.10)	.984 (25.00)	1.417 (36.00)	.343 (8.70)	.528 (13.40)	.984 (25.00)
4	N/A	.318 (8.10)	.563 (14.30)	1.150 (29.20)	1.593 (40.40)	.509 (12.90)	.693 (17.60)	1.150 (29.20)
6	.331 (8.40)	.543 (13.80)	.728 (18.50)	1.316 (33.40)	1.748 (44.40)	.673 (17.10)	.858 (21.80)	1.316 (33.40)
8	.496 (12.60)	.709 (18.00)	.894 (22.70)	1.480 (37.60)	1.913 (48.60)	.813 (20.80)	1.024 (26.00)	1.480 (37.60)
10	.661 (16.80)	.874 (22.20)	1.059 (26.90)	1.645 (41.80)	2.078 (52.80)	1.004 (25.50)	1.189 (30.20)	1.645 (41.80)
12	.827 (21.00)	1.039 (26.40)	1.224 (31.10)	1.811 (46.00)	2.244 (57.00)	1.169 (29.70)	1.354 (34.40)	1.811 (46.00)
14	.992 (25.20)	1.205 (30.60)	1.390 (35.30)	1.976 (50.20)	2.409 (61.20)	1.335 (33.90)	1.520 (38.60)	1.976 (50.20)
16	1.157 (29.40)	1.370 (34.80)	1.555 (39.50)	2.142 (54.40)	2.575 (65.40)	1.500 (38.10)	1.685 (42.80)	2.142 (54.40)
18	1.323 (33.60)	1.535 (39.00)	1.720 (43.70)	2.307 (58.60)	2.740 (69.60)	1.665 (42.30)	1.850 (47.00)	2.307 (58.60)
20	1.488 (37.80)	1.701 (43.20)	1.886 (47.90)	2.472 (62.80)	2.906 (73.80)	1.841 (46.50)	2.016 (51.20)	2.472 (62.80)
22	1.653 (42.00)	1.866 (47.40)	2.051 (52.10)	2.638 (67.00)	3.071 (78.00)	1.996 (50.70)	2.181 (55.40)	2.638 (67.00)
24	1.819 (46.20)	2.031 (51.60)	2.217 (56.30)	2.803 (71.20)	3.236 (82.20)	2.161 (54.90)	2.346 (59.60)	2.803 (71.20)

NOTES:

- MATERIAL:
 *1 = NYLON 6/6, 94V-2, COLOR: NATURAL.
 *2 = NYLON 6/6, 94V-0, COLOR: NATURAL.
 *3 = NYLON 6/6, 94V-2, COLOR: BLACK.
 *4 = NYLON 6/6, 94V-0, COLOR: BLACK.
- PART IS DESIGNED IN METRIC.
- PART TO BE USED WITH MOLEX FEMALE TERMINAL #5556.
- THIS DIMENSION TO BE USED FOR ALIGNMENT OF THE MATING CONNECTOR.
- THIS CONNECTOR ALLOWS FOR .050/(1.27) MAX. MISALIGNMENT IN ANY DIRECTION.
- A MAXIMUM TOLERANCE OF .050/(1.27) ALLOWS FOR 2 POINTS OF ELECTRICAL CONTACT. A MAXIMUM TOLERANCE OF .020/(.51) ALLOWS FOR 4 POINTS OF CONTACT.
- PART MATES WITH MINI-FIT B.M.I. PLUG #42475, AND HEADERS 42404, 42440, 43810, 44068 & 43879.
- PRODUCT SPECIFICATION: PS-5556-002
- CONNECTOR ASSEMBLIES ARE NOT TO BE MATED OR UNMATED WHILE CIRCUITS ARE LIVE.
- THIS PART IS INTENDED FOR ONE PANEL INSERTION ONLY; REMOVAL AND RE-INSERTION CAN DAMAGE THE MOUNTING SPIRALS.
- PANEL SHOULD BE PUNCHED IN THE DIRECTION OF CONNECTOR INSERTION.
- BOTH SPIRALS SHOULD BE INSERTED INTO THE PANEL AT THE SAME TIME; ROCKING THE PART INTO PLACE MAY CAUSE SPIRAL DAMAGE.
- THIS PART IS NOT INTENDED TO PROVIDE ANY ALIGNMENT OF CUSTOMER COMPONENTS OR MODULES, SUCH AS POWER SUPPLIES AND CHASSIS.
- IF THIS PRODUCT IS STORED IN AN ENVIRONMENT WITH A RELATIVE HUMIDITY OF LESS THAN 50%, MOISTURE MUST BE ADDED AS PER THE FOLLOWING:
 A) ADD 0.4 OZ. OF DEIONIZED WATER PER 1.0 LB. OF PRODUCT
 B) RESEAL PLASTIC BAG AFTER MOISTURIZATION

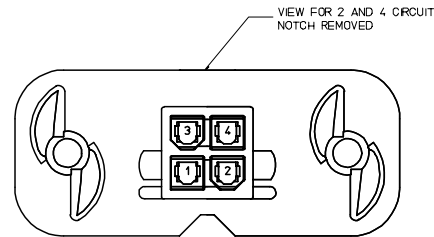

LEGEND:
 42474 - ** * 1
 BASE NUMBER
 CIRCUIT SIZE (02-24)
 MATERIAL (SEE NOTE 1.)

ADDED 4 CKT VIEW EC NO: UCP2006-0365 2005/08/15 DRW:NDUNNE 2005/08/15 CHK:KBPOLAR 2005/08/16 APPR: JCOMERL 2005/08/16	QUALITY SYMBOLS ▽=0 ▽=0	GENERAL TOLERANCES (UNLESS SPECIFIED) mm INCH 4 PLACES ±.004 ±.0005 3 PLACES ±.005 ±.0015 2 PLACES ±.038 ±.004 1 PLACE ±.004 ±.0015 ANGULAR ±1/2°	DIMENSION STYLE IN/MM DRAWN BY DATE GEP 8/24/89 CHECKED BY DATE RJF 8/24/89 APPROVED BY DATE RAS 8/2/89	SCALE 4:1 DESIGN UNITS METRIC THIRD ANGLE PROJECTION	TITLE PANEL-MOUNT RECEPTACLE BLIND MATE MINI-FIT JR. SERIES MOLEX INCORPORATED	MATERIAL NO. SD-42474-****	DOCUMENT NO. SHEET NO. 1 OF 2	
	DRAFT WHERE APPLICABLE MUST REMAIN WITHIN DIMENSIONS		SEE SHEET 2		THIS DRAWING CONTAINS INFORMATION THAT IS PROPRIETARY TO MOLEX INCORPORATED AND SHOULD NOT BE USED WITHOUT WRITTEN PERMISSION			
	DRAFT WHERE APPLICABLE MUST REMAIN WITHIN DIMENSIONS							
	SEE SHEET 2							

