

154BC

SPECIFICATIONS

- ◆ **Low Cost**
- ◆ **316L Stainless Steel or Titanium**
- ◆ **19mm Diameter Package**
- ◆ **0 - 100mV Output**
- ◆ **Gage and Absolute**
- ◆ **Wide Compensated Temperature Range**

The 154BC is a 19mm small profile, media compatible, piezoresistive silicon pressure sensor packaged in a 316L stainless steel or ASTM Grade 2 CP titanium housing. The 154BC is a low cost unit designed without a header for o-ring mounting and OEM applications where compatibility with corrosive media is required. The titanium option offers greater resistance to corrosive materials and harsh cleaning chemicals, opening the range of its application use to things such as dialysis machines and salt/brackish water measurements.

The sensing package utilizes silicone oil to transfer pressure from either a 316L stainless steel or titanium diaphragm to the sensing element. A ceramic substrate is attached to the package that contains laser-trimmed resistors for temperature compensation and offset correction. An additional laser-trimmed resistor is included which can be used to adjust an external differential amplifier and provide span interchangeability to within $\pm 1\%$.

Please refer to the 154N uncompensated and constant voltage datasheets for more information on different features of the 154.

FEATURES

- ◆ O-Ring Mount
- ◆ -20°C to +85°C Compensated Temperature
- ◆ 1.0% Interchangeable Span
1. (provided by gain set resistor)
- ◆ Solid State Reliability
- ◆ ±0.3% Pressure Non Linearity
- ◆ Titanium Option

APPLICATIONS

- ◆ Medical Instruments (Dialysis Machines)
- ◆ Process Control
- ◆ Fresh, Waste, Salt and Brackish Water Measurements
- ◆ Refrigeration/Compressors
- ◆ Pressure Transmitters
- ◆ Hydraulic Controls

STANDARD RANGES

Range (psi)	Gage	Range (Bar)	Absolute
0 to 015	◆		
0 to 030	◆		
0 to 050	◆		
0 to 100	◆	0 to 007	◆
		0 to 012	◆
		0 to 018	◆
0 to 300	◆	0 to 028	◆

PERFORMANCE SPECIFICATIONS

Supply Current: 1.5 mA

Ambient Temperature: 25°C (unless otherwise specified)

PARAMETERS	MIN	TYP	MAX	UNITS	NOTES
Span	75	100	150	mV	1
Zero Pressure Output	-1.0	0	1.0	mV	2
Pressure Non Linearity	-0.30		0.30	%Span	3
Pressure Hysteresis	-0.20		0.20	%Span	
Repeatability		±0.02		%Span	
Input Resistance	2.0	3.5	5.8	kΩ	3
Output Resistance	3.0		6.0	kΩ	
Temperature Error – Span	-1.0		1.0	%Span	4
Temperature Error – Offset	-1.0		1.0	%Span	4
Thermal Hysteresis – Span	-0.25	±0.05	0.25	%Span	4
Thermal Hysteresis – Offset	-0.25	±0.05	0.25	%Span	4
Long Term Stability – Span		±0.10		%Span/Year	
Long Term Stability – Offset		±0.25		%Span/Year	
Supply Current	0.5	1.5	2.0	mA	5
Output Load Resistance	5			MΩ	6
Insulation Resistance (50Vdc)	50			MΩ	7
Output Noise (10Hz to 1kHz)		1.0		μV p-p	
Response Time (10% to 90%)		0.1		ms	
Overload Pressure			2X	Rated	8
Burst Pressure			3X	Rated	9
Compensated Temperature	-20		+85	°C	
Operating Temperature	-40		+125	°C	10
Storage Temperature	-50		+125	°C	10
Media – Pressure Port	Liquids and Gases compatible with 316L Stainless Steel or ASTM Grade 2 CP Titanium				

Notes

1. For amplified output circuits, 3.012V ±1% interchangeability with gain set resistor. See application schematic.
2. Measured at vacuum for absolute (A), ambient for gage (G).
3. Best fit straight line.
4. Over the compensated temperature range with respect to 25°C.
5. Guarantees output/input ratiometricity.
6. Load resistance to reduce measurement errors due to output loading.
7. Between case and sensing element.
8. 2X or 500psi, whichever is less. The maximum pressure that can be applied without changing the transducer's performance or accuracy.
9. 3X or 600psi, whichever is less. The maximum pressure that can be applied to a transducer without rupture of either the sensing element or transducer.
10. Maximum temperature range for product with standard cable and connector is -20°C to +105°C.

DIMENSIONS

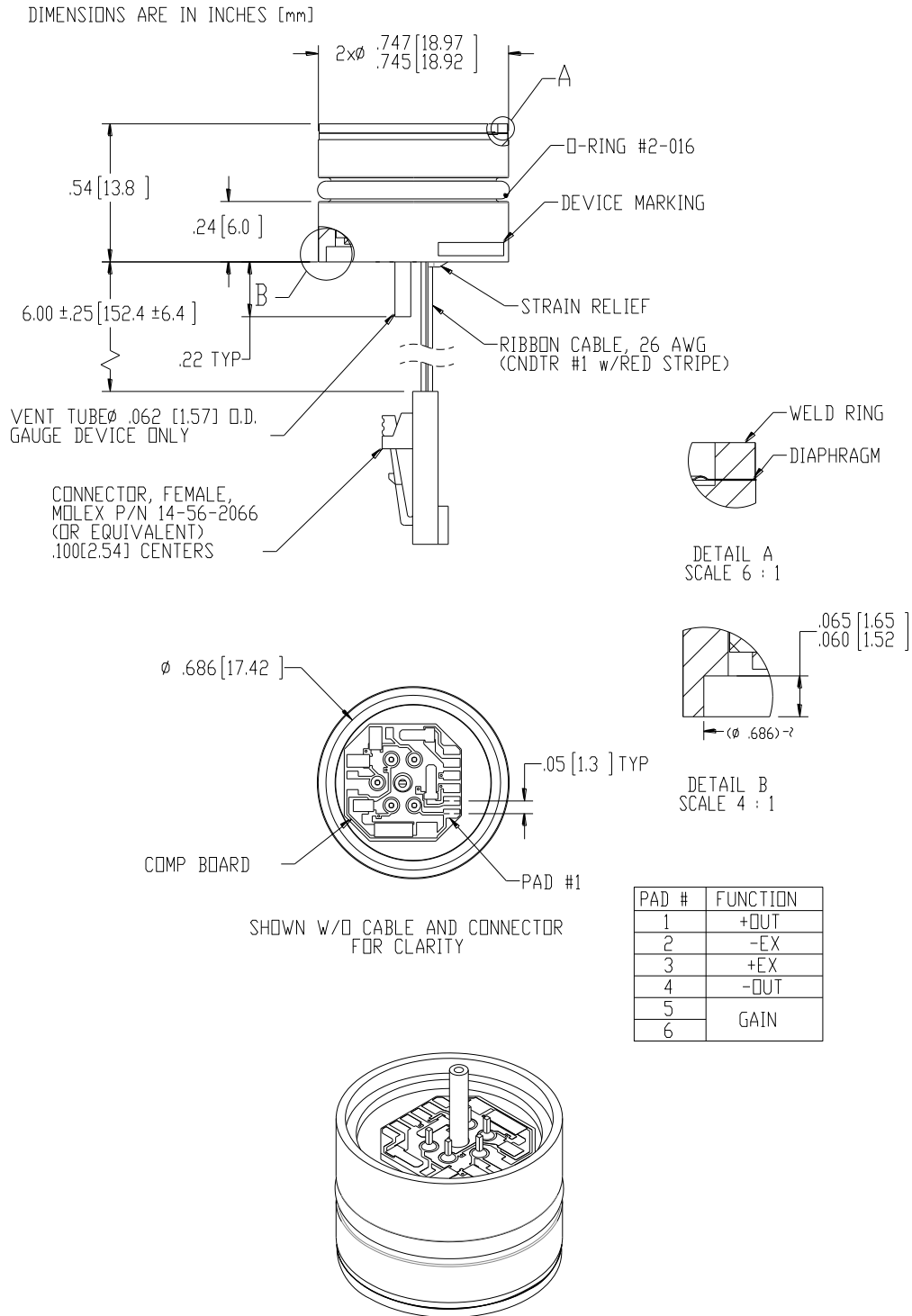

APPLICATION SCHEMATIC

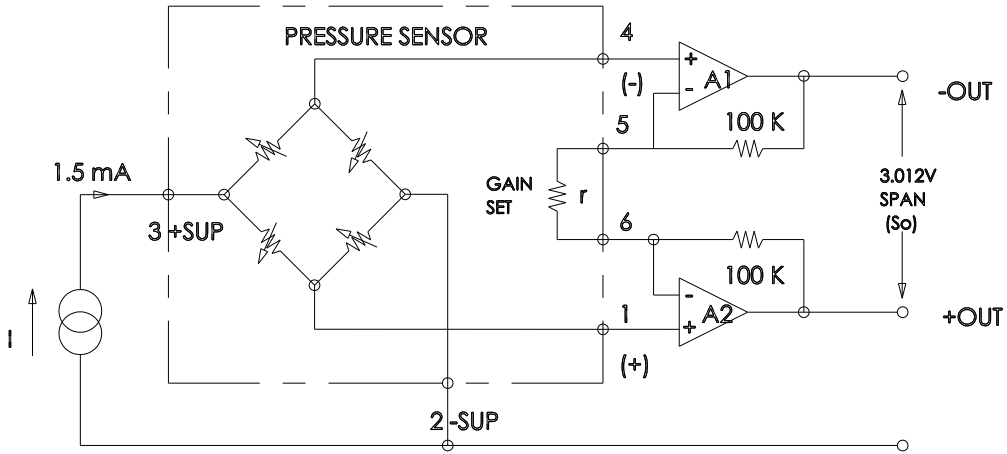

ORDERING INFORMATION

154BC	-	S	-	100PG	-	C
Model	-	Material	-	Pressure Type and Range	-	Electrical
154BC	-	S = 316L Stainless Steel T = ASTM Grade 2 CP Ti	-	015PG 030PG 050PG 100PG 300PG	-	007BA 012BA 018BA 028BA P = Solder Pads R = Ribbon Cable C = Cable w/ Connector

NORTH AMERICA

Measurement Specialties, Inc.,
a TE Connectivity Company
Tel: 800-522-6752 (option 2)
Email: customercare.fgmt@te.com

EUROPE

Measurement Specialties (Europe), Ltd.,
a TE Connectivity Company
Tel: 800-440-5100
Email: customercare.lcsb@te.com

ASIA

Measurement Specialties (China), Ltd.,
a TE Connectivity Company
Tel: 0400-820-6015
Email: customercare.shzn@te.com

TE.com/sensorsolutions

Measurement Specialties, Inc., a TE Connectivity company.

Measurement Specialties, TE Connectivity, TE Connectivity (logo) and EVERY CONNECTION COUNTS are trademarks. All other logos, products and/or company names referred to herein might be trademarks of their respective owners.

The information given herein, including drawings, illustrations and schematics which are intended for illustration purposes only, is believed to be reliable. However, TE Connectivity makes no warranties as to its accuracy or completeness and disclaims any liability in connection with its use. TE Connectivity's obligations shall only be as set forth in TE Connectivity's Standard Terms and Conditions of Sale for this product and in no case will TE Connectivity be liable for any incidental, indirect or consequential damages arising out of the sale, resale, use or misuse of the product. Users of TE Connectivity products should make their own evaluation to determine the suitability of each such product for the specific application.

© 2015 TE Connectivity Ltd. family of companies All Rights Reserved.

Mouser Electronics

Authorized Distributor

Click to View Pricing, Inventory, Delivery & Lifecycle Information:

TE Connectivity:

[154BC-S-028BA-C](#) [154BC-S-012BA-C](#) [154BC-T-015PG-C](#) [154BC-T-028BA-C](#) [154BC-S-030PG-C](#) [154BC-T-012BA-C](#) [154BC-T-030PG-C](#) [154BC-S-015PG-C](#)