

Professionally approved products.

Datasheet

RS BNC Male to Female Test Box, 2 Connectors, Blue

RS Stock 168-5208

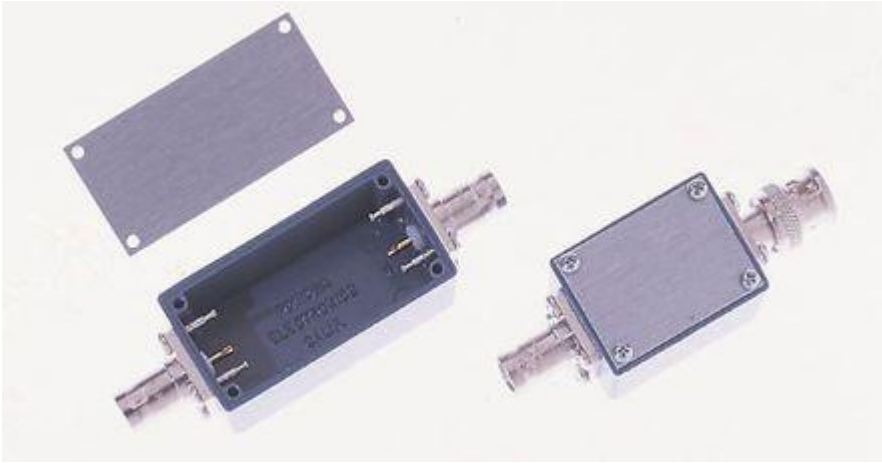

Dimensions: (mm)

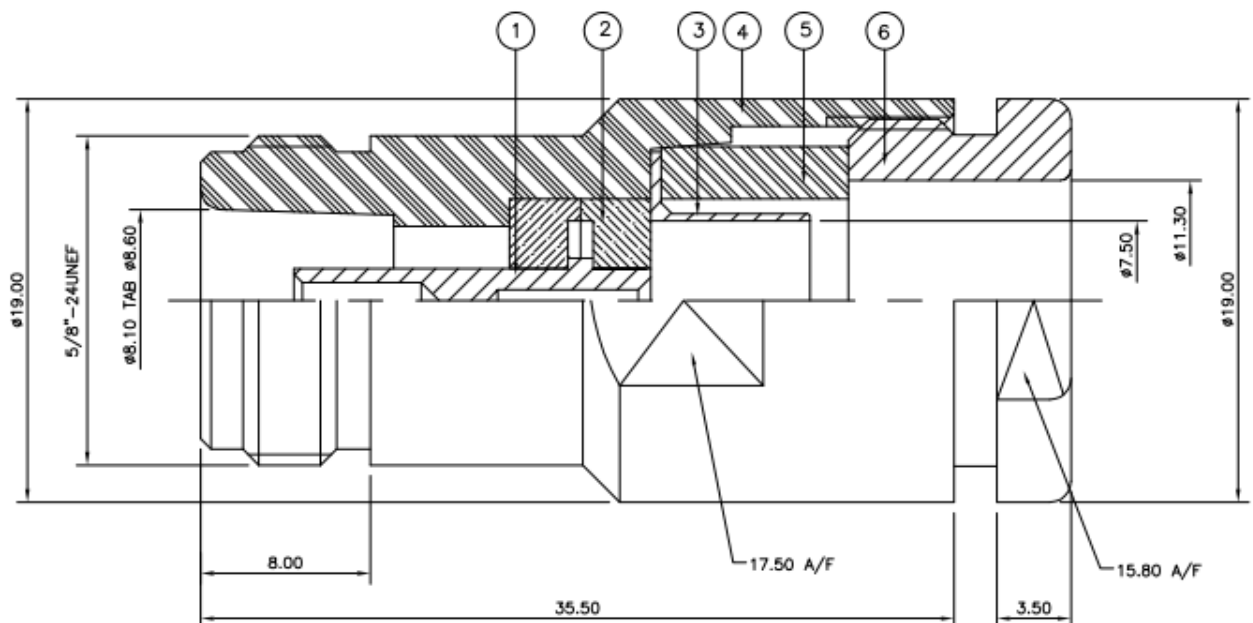

Professionally approved products.

Datasheet

Specifications

- Electrical Characteristics
 - Frequency Range: DC – 11 GHZ
 - Nominal Impedance: 50 Ohm
 - Insulation Resistance: 5000 Mohm
 - Working Voltage : 1000 Volts RMS at sea level
 - Dielectric Withstand Voltage: 2500 Volts RMS Max
- Contact Resistance
 - Centre contact: 1.00 mOhm max
 - Outer contact: 1.00 mOhm max
 - VSWR @ 4GHz: 1.30.1 Max
 - Insertion Loss dB @ x 4 Ghz: 0.30 Max
- Mechanical Characteristics
 - Coupling nut retention force N/A
 - Cable Retention Force: 350N Min
 - Clamp Nut Recommended Torque: 4.5N
 - Durability: 500 Cycles Min
- Environmental Characteristics:
 - Operating Temperature: -65 to +165 DegC

