

METRAL 5 ROW STANDARD, 1000, 2000, & 4000 SERIES, & EE HEADER / SHROUD INSERTION TOOLING

FEATURES:

- Inserts Metral 5 Row Standard, 1000, 2000, & 4000 Series, & EE headers onto a PCB.
- Inserts Metral 5 Row 1000 Series & 2000 Series shrouds onto the headers installed on the PCB.**
 **Metral standard 5 row shroud can be installed w/ 166624-xxx shroud press block. See the Info sheet for Metral 4 & 5 Row Standard Shroud Insertion Tooling.
- End-to-End stackable.
- Use manually or in an automatic insertion machine.
- Polarization keys insure proper tooling-to-connector alignment.
- End web design allows tooling to fit within length of connector & prevents end wall damage.
- Press block can be used as bottom PCB support.

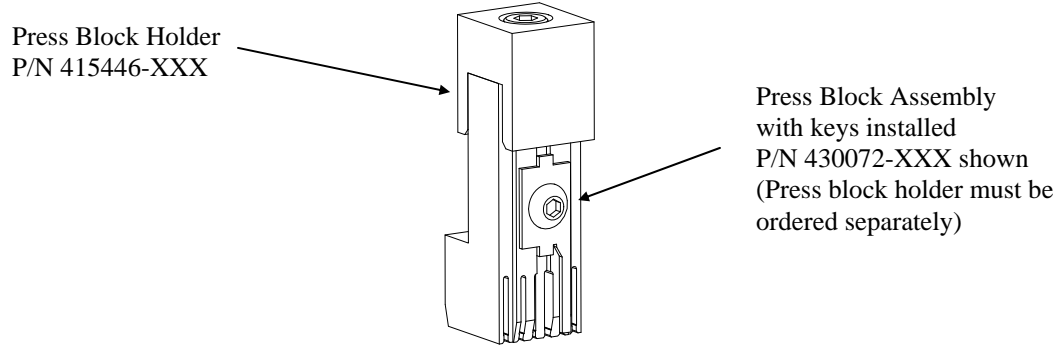

5 ROW WIDE BODY PRESS BLOCK ASS'Y P/N:

TOOLING P/N

PRODUCT DESCRIPTION

<u>430072-001</u>	1 module Metral 5 row Standard 1000, 2000, & 4000 series & EE header/shroud press block
<u>430072-002</u>	2 module Metral 5 row Standard 1000, 2000, & 4000 series & EE header/shroud press block
<u>430072-003</u>	4 module Metral 5 row Standard 1000, 2000, & 4000 series & EE header/shroud press block
<u>430072-004</u>	8 module Metral 5 row Standard 1000, 2000, & 4000 series & EE header/shroud press block

5 ROW WIDE BODY EXTENDED PRESS BLOCK ASS'Y P/N:

TOOLING P/N

PRODUCT DESCRIPTION

<u>430075-001</u>	1 Module Metral 5 Row 1000 & 2000 Series Wide Body header/shroud press block
<u>430075-002</u>	2 Module Metral 5 Row 1000 & 2000 Series Wide Body header/shroud press block
<u>430075-003</u>	4 Module Metral 5 Row 1000 & 2000 Series Wide Body header/shroud press block
<u>430075-004</u>	8 Module Metral 5 Row 1000 & 2000 Series Wide Body header/shroud press block

4 & 5 ROW PRESS BLOCK HOLDER P/N:

<u>415446-001</u>	1 – 12 mm module	<u>415446-013</u>	12 – 12 mm modules
<u>415446-002</u>	2 – 12 mm modules	<u>415446-014</u>	13 – 12 mm modules
<u>415446-003</u>	4 – 12 mm modules	<u>415446-015</u>	14 – 12 mm modules
<u>415446-004</u>	8 – 12 mm modules	<u>415446-016</u>	15 – 12 mm modules
<u>415446-005</u>	21 – 12 mm modules	<u>415446-017</u>	16 – 12 mm modules
<u>415446-006</u>	3 – 12 mm modules	<u>415446-018</u>	17 – 12 mm modules
<u>415446-007</u>	5 – 12 mm modules	<u>415446-019</u>	18 – 12 mm modules
<u>415446-008</u>	6 – 12 mm modules	<u>415446-020</u>	19 – 12 mm modules
<u>415446-009</u>	7 – 12 mm modules	<u>415446-021</u>	20 – 12 mm modules
<u>415446-010</u>	9 – 12 mm modules	<u>415446-101</u>	21 – 12 mm modules
<u>415446-011</u>	10 – 12 mm modules		
<u>415446-012</u>	11 – 12 mm modules		

5 ROW BOARD SUPPORT: (for use with 5 Row Metral Headers Only – not to be used with shrouds)

<u>415609-001</u>	1- 12 mm module	<u>415609-003</u>	1- 48 mm module
<u>415609-002</u>	1- 24 mm module	<u>415609-004</u>	1- 96 mm module

PRESSES TO INSERT METRAL 5 ROW STANDARD, 1000, 2000, & 4000 SERIES VERTICAL HEADERS & SHROUDS

Metral vertical press-fit headers and shrouds can be installed with any standard press as long as it has enough force to properly install the number of pins that are being inserted.

FCI also offers a manual press that can be used to insert up to 4 modules at a time. Insertion tooling must be purchased separately. Bottom tooling is not supplied since most customers prefer to design their own support fixtures, or use a PCB with oversized holes.

MT-301 HAND PRESS P/N 194205-002

- Inserts up to 4 modules at a time.
- Height of ram is adjustable from 1.5” to 6.5”
- Throat depth is 4.5” to center of ram
- Press capacity is 1 ton

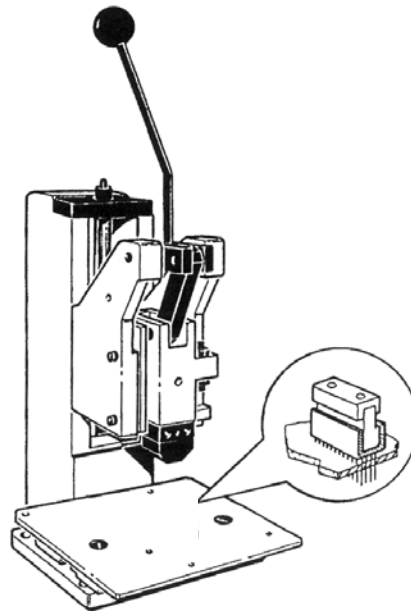

Impress Press

FCI manufactures a complete line of servo-driven electric presses to install all press fit connectors. The Impress line of presses range from a manual placement, operator actuated press to a fully automated pick, place, and press unit. The entire line up of machine features includes state of the art electronic press controls with a closed loop feedback system. Contact your local sales representative for additional information on the Impress line of presses or visit our website at www.FCICONNECT.COM.

Mouser Electronics

Authorized Distributor

Click to View Pricing, Inventory, Delivery & Lifecycle Information:

[FCI / Amphenol:](#)

[415446-003](#) [415446-014](#) [430075-003](#) [415446-001](#)