

SN54182, SN54S182, SN74182, SN74S182

Look-Ahead Carry Generators

The SN54182, SN54S182, SN74182, and SN74S182 are high-speed, look-ahead carry generators capable of anticipating a carry across four binary adders or group of adders. They are cascadable to perform full look-ahead across n-bits adders.

When used in conjunction with the '181, 'LS181, or 'S181 arithmetic logic unit (ALU), these generators provide high-speed carry look-ahead capability for any word length. Each '182 or 'S182 generates the look-ahead (anticipated carry) across a group of four ALU's and, in addition, other carry look-ahead circuits may be employed to anticipate carry across sections of four look-ahead packages up to n-bits.

Rochester Electronics Manufactured Components

Rochester branded components are manufactured using either die/wafers purchased from the original suppliers or Rochester wafers recreated from the original IP. All recreations are done with the approval of the OCM.

Parts are tested using original factory test programs or Rochester developed test solutions to guarantee product meets or exceeds the OCM data sheet.

Quality Overview

- ISO-9001
- AS9120 certification
- Qualified Manufacturers List (QML) MIL-PRF-38535
 - Class Q Military
 - Class V Space Level
- Qualified Suppliers List of Distributors (QSLD)
 - Rochester is a critical supplier to DLA and meets all industry and DLA standards.

Rochester Electronics, LLC is committed to supplying products that satisfy customer expectations for quality and are equal to those originally supplied by industry manufacturers.

The original manufacturer's datasheet accompanying this document reflects the performance and specifications of the Rochester manufactured version of this device. Rochester Electronics guarantees the performance of its semiconductor products to the original OEM specifications. 'Typical' values are for reference purposes only. Certain minimum or maximum ratings may be based on product characterization, design, simulation, or sample testing.

TYPES SN54182, SN54S182, SN74182, SN74S182 LOOK-AHEAD CARRY GENERATORS

BULLETIN NO. DL-S 7611823, DECEMBER 1972—REVISED OCTOBER 1976

- Directly Compatible for Use With:
SN54181/SN74181, SN54LS181/SN74LS181,
SN54S281/SN74S281, SN54S381, SN74S381,
SN54S481/SN74S481

SN54182, SN54S182 ... J OR W PACKAGE
SN74182 ... J OR N PACKAGE
SN74S182 ... D, J OR N PACKAGE
(TOP VIEW)

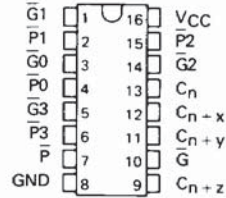

SN54S182 ... FK PACKAGE
SN74S182 ... FN PACKAGE
(TOP VIEW)

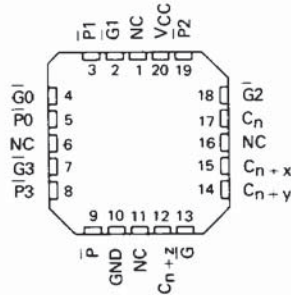

NC - No internal connection

PIN DESIGNATIONS

ALTERNATIVE DESIGNATIONS†	DESIGNATIONS†	PIN NOS.	FUNCTION
$\bar{G}_0, \bar{G}_1, \bar{G}_2, \bar{G}_3$	G0, G1, G2, G3	3, 1, 14, 5	CARRY GENERATE INPUTS
$\bar{P}_0, \bar{P}_1, \bar{P}_2, \bar{P}_3$	P0, P1, P2, P3	4, 2, 15, 6	CARRY PROPAGATE INPUTS
C_n	C_n	13	CARRY INPUT
$C_{n+x}, C_{n+y}, C_{n+z}$	$C_{n+x}, C_{n+y}, C_{n+z}$	12, 11, 9	CARRY OUTPUTS
G	Y	10	CARRY GENERATE OUTPUT
\bar{P}	X	7	CARRY PROPAGATE OUTPUT
	VCC	16	SUPPLY VOLTAGE
	GND	8	GROUND

† Interpretations are illustrated in the '181, 'LS181, 'S181 data sheet.

logic symbol†

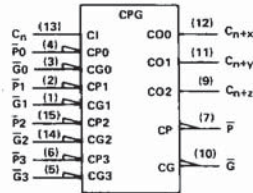

Pin numbers shown on logic notation are for D, J or N packages.

description

The SN54182, SN54S182, SN74182, and SN74S182 are high-speed, look-ahead carry generators capable of anticipating a carry across four binary adders or group of adders. They are cascaded to perform full look-ahead across n-bit adders. Carry, generate-carry, and propagate-carry functions are provided as enumerated in the pin designation table above.

When used in conjunction with the '181, 'LS181, or 'S181 arithmetic logic unit (ALU), these generators provide high-speed carry look-ahead capability for any word length. Each '182 or 'S182 generates the look-ahead (anticipated carry) across a group of four ALU's and, in addition, other carry look-ahead circuits may be employed to anticipate carry across sections of four look-ahead packages up to n-bits. The method of cascading '182 or 'S182 circuits to perform multi-level look-ahead is illustrated under typical application data.

The carry functions (inputs, outputs, generate, and propagate) of the look-ahead generators are implemented in the compatible forms for direct connection to the ALU. Reinterpretations of carry functions as explained on the '181, 'LS181, and 'S181 data sheet are also applicable to and compatible with the look-ahead generator. Logic equations for the '182 and 'S182 are:

$$\begin{aligned}
 C_{n+x} &= G_0 + P_0 C_n & \bar{C}_{n+x} &= \bar{Y}_0 (X_0 + C_n) \\
 C_{n+y} &= G_1 + P_1 G_0 + P_1 P_0 C_n & \bar{C}_{n+y} &= \bar{Y}_1 [X_1 + Y_0 (X_0 + C_n)] \\
 C_{n+z} &= G_2 + P_2 G_1 + P_2 P_1 G_0 + P_2 P_1 P_0 C_n & \bar{C}_{n+z} &= \bar{Y}_2 \{X_2 + Y_1 [X_1 + Y_0 (X_0 + C_n)]\} \\
 G &= G_3 + P_3 G_2 + P_3 P_2 G_1 + P_3 P_2 P_1 G_0 & Y &= Y_3 (X_3 + Y_2) (X_3 + X_2 + Y_1) (X_3 + X_2 + X_1 + Y_0) \\
 \bar{P} &= P_3 P_2 P_1 P_0 & X &= X_3 + X_2 + X_1 + X_0
 \end{aligned}$$

PRODUCTION DATA

This document contains information current as of publication date. Products conform to specifications per the terms of Texas Instruments standard warranty. Production processing does not necessarily include testing of all parameters.

TEXAS
INSTRUMENTS

POST OFFICE BOX 225012 • DALLAS, TEXAS 75265

3-721

3

TTL DEVICES

**TYPES SN54182, SN54S182, SN74182, SN74S182
LOOK-AHEAD CARRY GENERATORS**

logic

logic diagram

FUNCTION TABLE FOR \bar{G} OUTPUT

INPUTS							OUTPUT
\bar{G}_3	\bar{G}_2	\bar{G}_1	\bar{G}_0	\bar{P}_3	\bar{P}_2	\bar{P}_1	\bar{G}
L	X	X	X	X	X	X	L
X	L	X	X	L	X	X	L
X	X	L	X	L	L	X	L
X	X	X	L	L	L	L	L
All other combinations							H

FUNCTION TABLE FOR \bar{P} OUTPUT

INPUTS				OUTPUT
\bar{P}_3	\bar{P}_2	\bar{P}_1	\bar{P}_0	\bar{P}
L	L	L	L	L
All other combinations				H

FUNCTION TABLE FOR C_{n+x} OUTPUT

INPUTS			OUTPUT
\bar{G}_0	\bar{P}_0	C_n	C_{n+x}
L	X	X	H
X	L	H	H
All other combinations			L

FUNCTION TABLE FOR C_{n+y} OUTPUT

INPUTS					OUTPUT
\bar{G}_1	\bar{G}_0	\bar{P}_1	\bar{P}_0	C_n	C_{n+y}
L	X	X	X	X	H
X	L	L	X	X	H
X	X	L	L	H	H
All other combinations					L

FUNCTION TABLE FOR C_{n+z} OUTPUT

INPUTS							OUTPUT
\bar{G}_2	\bar{G}_1	\bar{G}_0	\bar{P}_2	\bar{P}_1	\bar{P}_0	C_n	C_{n+z}
L	X	X	X	X	X	X	H
X	L	X	L	X	X	X	H
X	X	L	L	L	X	X	H
X	X	X	L	L	L	H	H
All other combinations							L

H = high level, L = low level, X = irrelevant
Any inputs not shown in a given table are irrelevant with respect to that output.

absolute maximum ratings over operating free-air temperature range (unless otherwise noted)

Supply voltage, V_{CC} (see Note 1)	7 V
Input voltage	5.5 V
Intermitter voltage (see Note 2)	5.5 V
Operating free-air temperature range: SN54', SN54S' Circuits	-55°C to 125°C
SN74', SN74S' Circuits	0°C to 70°C
Storage temperature range	-65°C to 150°C

NOTES: 1. Voltage values, except intermitter voltage, are with respect to network ground terminal.
2. This is the voltage between two emitters of a multiple-emitter input transistor. For these circuits, this rating applies to each \bar{G} input in conjunction with any other \bar{G} input or in conjunction with any \bar{P} input.

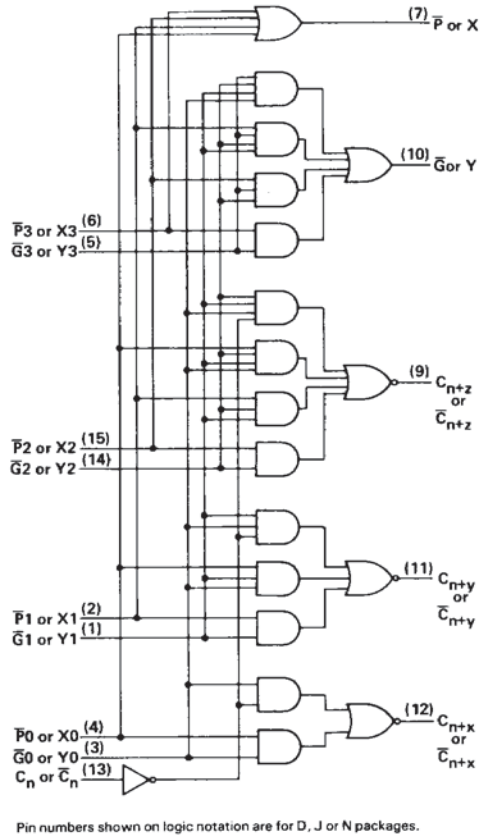

3 TTL DEVICES

TYPES SN54182, SN74182
LOOK-AHEAD CARRY GENERATORS

recommended operating conditions

	SN54182			SN74182			UNIT
	MIN	NOM	MAX	MIN	NOM	MAX	
Supply voltage, V_{CC}	4.5	5	5.5	4.75	5	5.25	V
High-level output current, I_{OH}			-800			-800	μ A
Low-level output current, I_{OL}			16			16	mA
Operating free-air temperature, T_A	-55		125	0		70	$^{\circ}$ C

electrical characteristics over recommended operating free-air temperature range (unless otherwise noted)

PARAMETER		TEST CONDITIONS [†]	SN54182			SN74182			UNIT
			MIN	TYP [‡]	MAX	MIN	TYP [‡]	MAX	
V_{IH}	High-level input voltage		2			2			V
V_{IL}	Low-level input voltage				0.8			0.8	V
V_{IK}	Input clamp voltage	$V_{CC} = \text{MIN}, I_I = -12 \text{ mA}$			-1.5			-1.5	V
V_{OH}	High-level output voltage	$V_{CC} = \text{MIN}, V_{IH} = 2 \text{ V}, V_{IL} = 0.8 \text{ V}, I_{OH} = -800 \mu\text{A}$	2.4	3.4		2.4	3.4		V
V_{OL}	Low-level output voltage	$V_{CC} = \text{MIN}, V_{IH} = 2 \text{ V}, V_{IL} = 0.8 \text{ V}, I_{OL} = 16 \text{ mA}$		0.2	0.4		0.2	0.4	V
I_I	Input current at maximum input voltage	$V_{CC} = \text{MAX}, V_I = 5.5 \text{ V}$			1			1	mA
I_{IH}	High-level input current	C_n input			80			80	μ A
		$\overline{P}3$ input			120			120	
		$\overline{P}2$ input			160			160	
		$\overline{P}0, \overline{P}1, \text{ or } \overline{G}3$ input			200			200	
		$\overline{G}0$ or $\overline{G}2$ input			360			360	
		$\overline{G}1$ input			400			400	
I_{IL}	Low-level input current	C_n input			-3.2			-3.2	mA
		$\overline{P}3$ input			-4.8			-4.8	
		$\overline{P}2$ input			-6.4			-6.4	
		$\overline{P}0, \overline{P}1, \text{ or } \overline{G}3$ input			-8			-8	
		$\overline{G}0$ or $\overline{G}2$ input			-14.4			-14.4	
		$\overline{G}1$ input			-16			-16	
I_{OS}	Short-circuit output current [§]	$V_{CC} = \text{MAX}$	-40		-100	-40		-100	mA
I_{CCH}	Supply current, all outputs high	$V_{CC} = 5 \text{ V},$ See Note 3		27			27		mA
I_{CCL}	Supply current, all outputs low	$V_{CC} = \text{MAX},$ See Note 4	45	65		45	72		mA

[†]For conditions shown as MIN or MAX, use the appropriate value specified under recommended operating conditions.

[‡]All typical values are at $V_{CC} = 5 \text{ V}, T_A = 25^{\circ}\text{C}$.

[§]Not more than one output should be shorted at a time and duration of the short-circuit test should not exceed one second.

NOTES: 3. I_{CCH} is measured with all outputs open, inputs $\overline{P}3$ and $\overline{G}3$ at 4.5 V, and all other inputs grounded.

4. I_{CCL} is measured with all outputs open; inputs $\overline{G}0, \overline{G}1,$ and $\overline{G}2$ at 4.5 V; and all other inputs grounded.

switching characteristics, $V_{CC} = 5 \text{ V}, T_A = 25^{\circ}\text{C}$

PARAMETER	TEST CONDITIONS	MIN	TYP	MAX	UNIT
t_{PLH}	Propagation delay time, low-to-high-level output		11	17	ns
t_{PHL}	Propagation delay time, high-to-low-level output		15	22	ns

NOTE 5: See General Information Section for load circuits and voltage waveforms.

3

TTL DEVICES

TYPES SN54S182, SN74S182
LOOK-AHEAD CARRY GENERATORS

recommended operating conditions

	SN54S182			SN74S182			UNIT
	MIN	NOM	MAX	MIN	NOM	MAX	
Supply voltage, V_{CC}	4.5	5	5.5	4.75	5	5.25	V
High-level output current, I_{OH}			-1			-1	mA
Low-level output current, I_{OL}			20			20	mA
Operating free-air temperature, T_A	-55		125	0		70	°C

electrical characteristics over recommended operating free-air temperature range (unless otherwise noted)

PARAMETER		TEST CONDITIONS†	SN54S182			SN74S182			UNIT
			MIN	TYP‡	MAX	MIN	TYP‡	MAX	
V_{IH}	High-level input voltage		2			2			V
V_{IL}	Low-level input voltage				0.8			0.8	V
V_{IK}	Input clamp voltage	$V_{CC} = \text{MIN}, I_I = -18 \text{ mA}$			-1.2			-1.2	V
V_{OH}	High-level output voltage	$V_{CC} = \text{MIN}, V_{IH} = 2 \text{ V}, V_{IL} = 0.8 \text{ V}, I_{OH} = -1 \text{ mA}$	2.5	3.4		2.7	3.4		V
V_{OL}	Low-level output voltage	$V_{CC} = \text{MIN}, V_{IH} = 2 \text{ V}, V_{IL} = 0.8 \text{ V}, I_{OL} = 20 \text{ mA}$			0.5			0.5	V
I_I	Input current at maximum input voltage	$V_{CC} = \text{MAX}, V_I = 5.5 \text{ V}$			1			1	mA
I_{IH}	High-level input current	C_n input			50			50	μA
		$\bar{P}3$ input			100			100	
		$\bar{P}2$ input			150			150	
		$\bar{P}0, \bar{P}1, \text{ or } \bar{G}3$ input			200			200	
		$\bar{G}0$ or $\bar{G}2$ input			350			350	
		$\bar{G}1$ input			400			400	
I_{IL}	Low-level input current	C_n input			-2			-2	mA
		$\bar{P}3$ input			-4			-4	
		$\bar{P}2$ input			-6			-6	
		$\bar{P}0, \bar{P}1, \text{ or } \bar{G}3$ input			-8			-8	
		$\bar{G}0$ or $\bar{G}2$ input			-14			-14	
		$\bar{G}1$ input			-16			-16	
I_{OS}	Short-circuit output current‡	$V_{CC} = \text{MAX}$	-40	-100		-40	-100	mA	
I_{CCH}	Supply current, all outputs high	$V_{CC} = 5 \text{ V},$ See Note 3		35			35	mA	
I_{CCL}	Supply current, all outputs low	$V_{CC} = \text{MAX},$ See Note 4		69 99			69 109	mA	

† For conditions shown as MIN or MAX, use the appropriate value specified under recommended operating conditions for the applicable type.

‡ All typical values are at $V_{CC} = 5 \text{ V}, T_A = 25^\circ \text{C}$.

§ Not more than one output should be shorted at a time and duration of the short-circuit test should not exceed one second.

NOTES: 3. I_{CCH} is measured with all outputs open, inputs $\bar{P}3$ and $\bar{G}3$ at 4.5 V, and all other inputs grounded.

4. I_{CCL} is measured with all outputs open; inputs $\bar{G}0, \bar{G}1,$ and $\bar{G}2$ at 4.5 V; and all other inputs grounded.

switching characteristics, $V_{CC} = 5 \text{ V}, T_A = 25^\circ \text{C}$

PARAMETER¶	FROM (INPUT)	TO (OUTPUT)	TEST CONDITIONS	MIN	TYP	MAX	UNIT
t_{PLH}	$\bar{G}0, \bar{G}1, \bar{G}2, \bar{G}3,$	$C_{n+x}, C_{n+y},$	$R_L = 280 \Omega, C_L = 15 \text{ pF},$ See Note 5	4.5	7		ns
t_{PHL}	$P0, P1, P2, \text{ or } P3$	or C_{n+z}		4.5	7		
t_{PLH}	$\bar{G}0, \bar{G}1, \bar{G}2, \bar{G}3,$	\bar{G}		5	7.5		ns
t_{PHL}	$P1, P2, \text{ or } P3$			7	10.5		
t_{PLH}	$\bar{P}0, \bar{P}1, \bar{P}2, \text{ or } \bar{P}3$	\bar{P}		4.5	6.5		ns
t_{PHL}				6.5	10		
t_{PLH}	C_n	$C_{n+x}, C_{n+y},$		6.5	10		ns
t_{PHL}		or C_{n+z}		7	10.5		

¶ t_{PLH} = propagation delay time, low-to-high-level output

¶ t_{PHL} = propagation delay time, high-to-low-level output

NOTE 5: See General Information Section for load circuits and voltage waveforms.

3

TTL DEVICES

TYPES SN54182, SN54S182, SN74182, SN74S182
LOOK-AHEAD CARRY GENERATORS

schematics of inputs and outputs

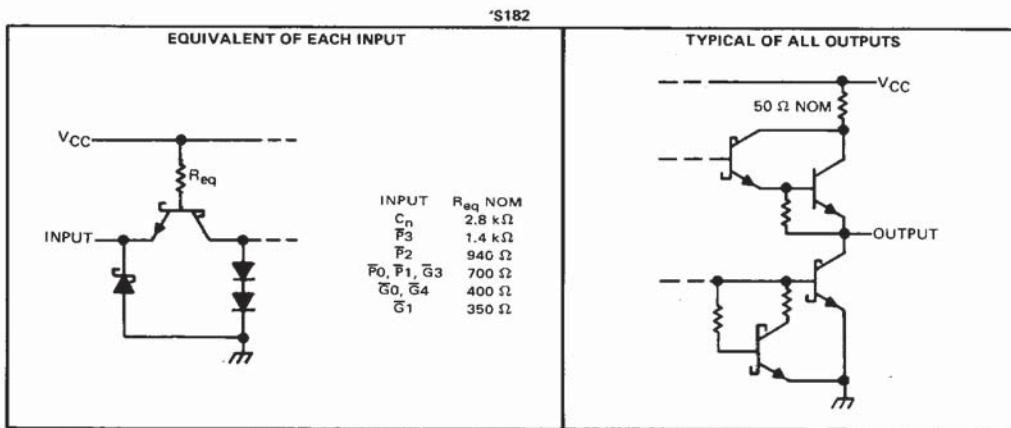
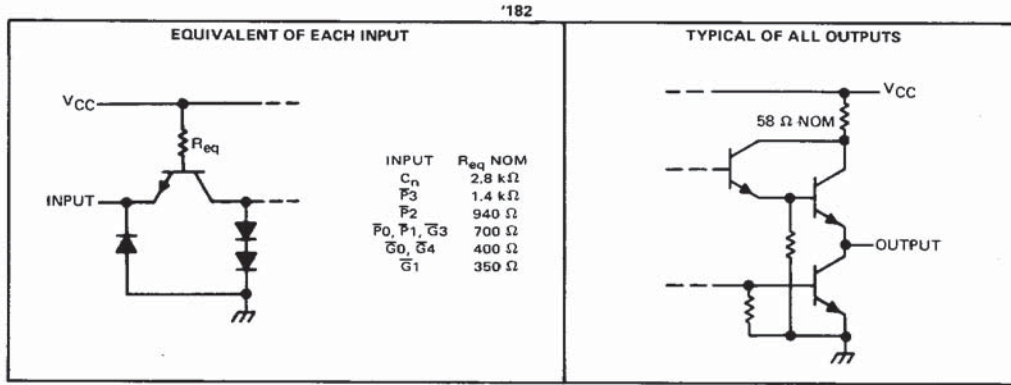

3
TTL DEVICES

TYPES SN54182, SN54S182, SN74182, SN74S182
LOOK-AHEAD CARRY GENERATORS



TTL DEVICES

TYPICAL APPLICATION DATA

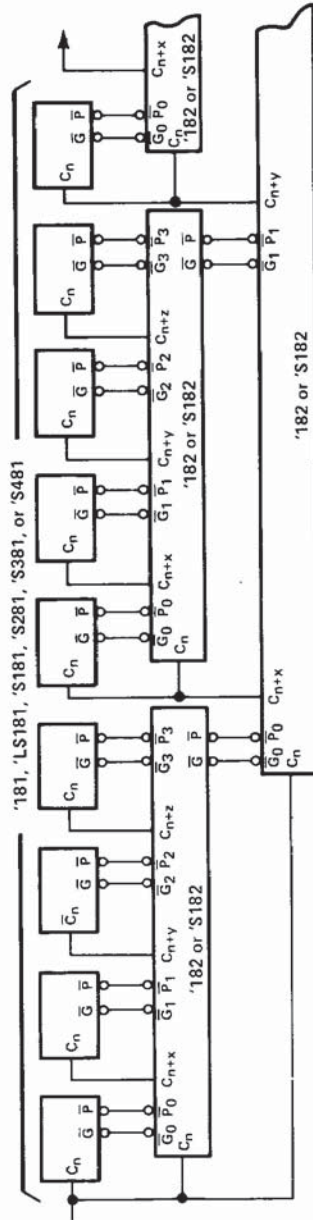

64-BIT ALU, FULL-CARRY LOOK-AHEAD IN THREE LEVELS

Remaining inputs and outputs of '181, 'LS181, 'S181, 'S281, 'S381, and 'S481 are not shown.