

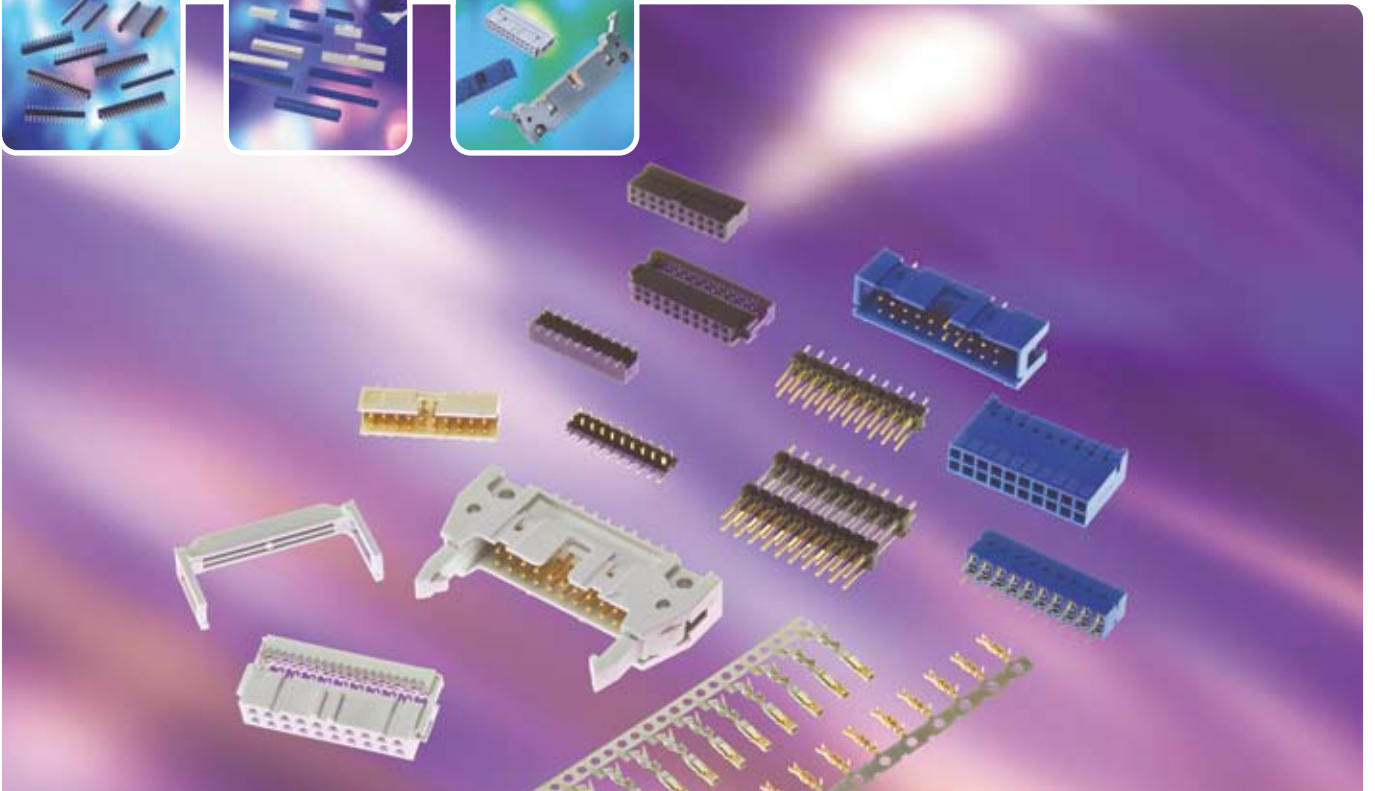

NEW
SHORT LEAD TIMES
www.fci.com/basicstleadtimes



 Product Catalog



FCI: SETTING THE STANDARD FOR CONNECTORS

With operations in 30 countries and sales of 1.3 billion euros in 2007, FCI is a leading manufacturer of connectors. Our 14,200 employees are committed to providing customers with high-quality, innovative products for a wide range of consumer and industrial applications.



SELECT YOUR STANDARD PART FROM THIS CATALOG OR THE BASICS+ MICROSITE

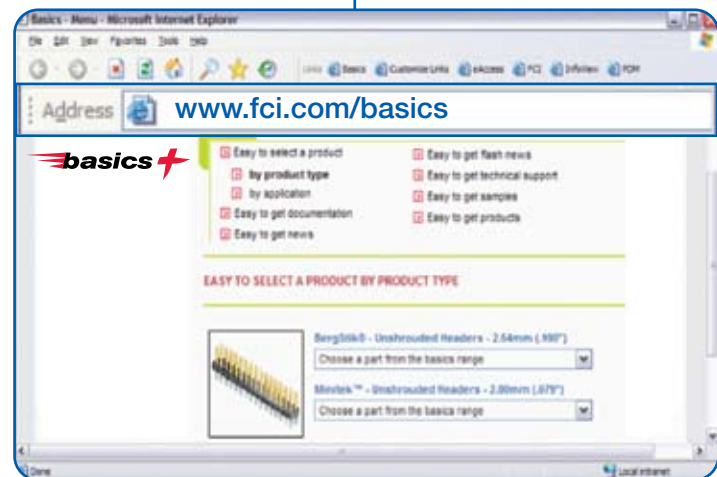

ORDER YOUR FAST SHIPMENT SAMPLES ONLINE

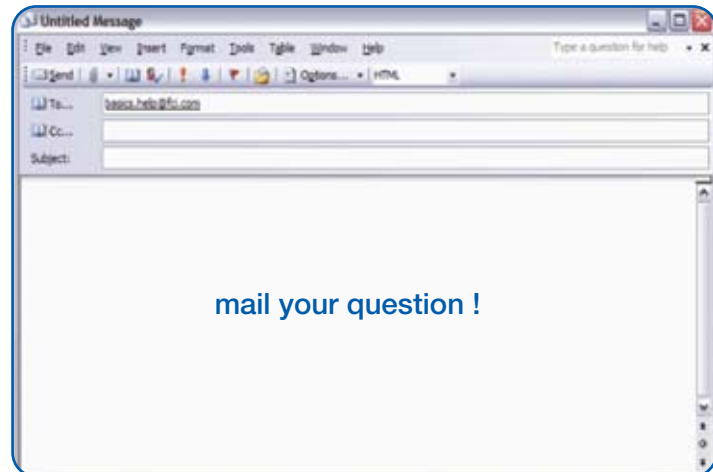

GET THE TECHNICAL HELP YOU NEED FROM [BASICS.HELP@FCI.COM](mailto:basics.help@fci.com)

RE SERVICE. LESS WAITING.

■ CATALOG PARTS NORMALLY AVAILABLE FOR SHIPMENT IN 3 DAYS. CHECK ONLINE !

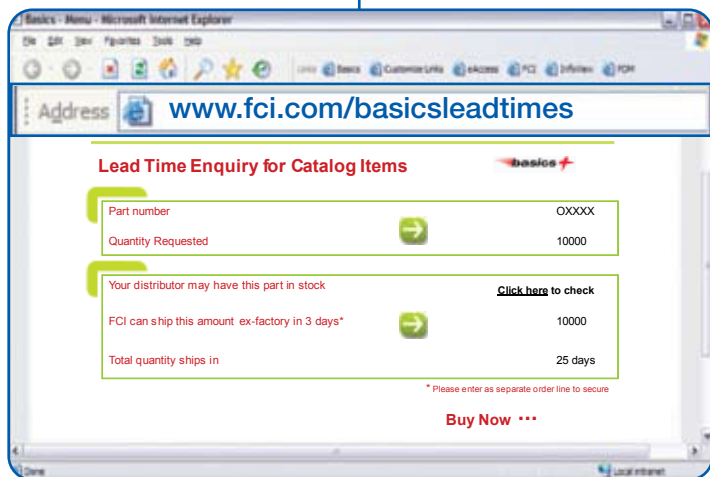

■ OR GET THE SPECIAL YOU NEED VIA THE BASICS+ DESIGN SERVICE

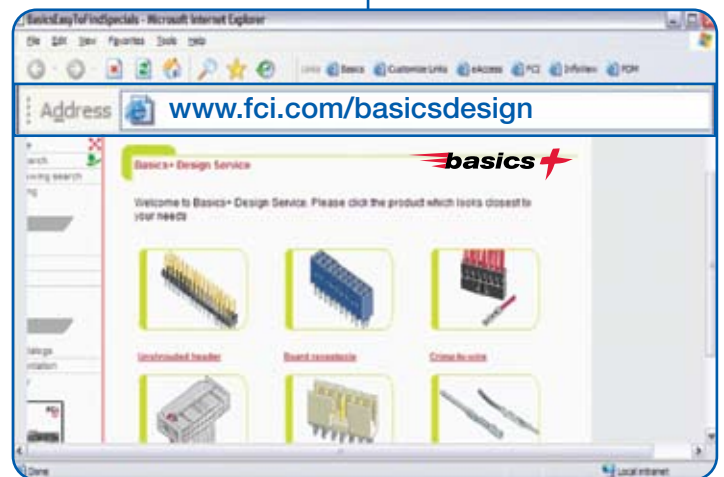

■ NEED SOME PRODUCTION GRADE PARTS FOR YOUR PRE-SERIES? PHONE OUR CUSTOMER SERVICE

UNSHROUDED HEADERS



BergStik® Unshrouded Headers 2.54mm (.100")

Vertical - standard sizes	8
Vertical - custom sizes	10
Vertical - continuous	12
Right angle - standard sizes	14
Right angle - custom sizes	16
Stacking headers	18

Minitek™ Unshrouded Headers 2.00mm (.079")

Vertical	52
Right angle	54
Pin-in-Paste	56
Stacking	58

SHROUDED HEADERS



Dubox™ Shrouded Headers 2.54mm (.100)

30

PV™ Superior Performance Shrouded Headers 2.54mm (.100")

36

Minitek™ Shrouded Headers 2.00mm (.079")

Vertical	64
Right angle	66
Pin-in-Paste	68
Eject latch	70

Quickie® Shrouded Headers 2.54mm (.100")

Low Profile	42
Surface Mount and Pin-in-Paste	44
Eject latch	46

BOARD-TO-BOARD RECEPTACLES



Dubox™ Board-to-Board Receptacles 2.54mm (.100")

Vertical	22
Low profile vertical - through mount	24
Low profile vertical - surface mount	26
Horizontal	28

Minitek™ Vertical receptacles

60

CRIMP-TO-WIRE TERMINALS AND HOUSINGS



Dubox™ Crimp-To-Wire 2.54mm (.100")

Contacts	32
Housings	34

PV™ Superior Performance Crimp-To-Wire 2.54mm (.100")

Contacts	38
Housings	40

Minitek™ Crimp-To-Wire 2.00mm (.079")

Contacts	72
Housings	72
Active latch	74

IDC RECEPTACLES



Quickie® IDC Receptacles 2.54mm (.100")

48

Quickie® IDC PCB connector 2.54mm (.100")

50

Minitek™ IDC strain relief

76

SHUNTS



Dubox™ Shunts 2.54mm (.100")

20

Minitek™ Shunts 2.00mm (.079")

62

MORE OPTIONS

78

APPLICATION EQUIPMENT

80

PART NUMBER INDEX

82



Pick an item from anywhere in the catalog. Most parts available to ship from our factory to you in 3 days. Check online at www.fci.com/basics/leadtimes

Pin-in-Paste

Our new PiP range has been specifically designed to meet the requirements of this process, complete with paste stencil design
Pages 56, 68

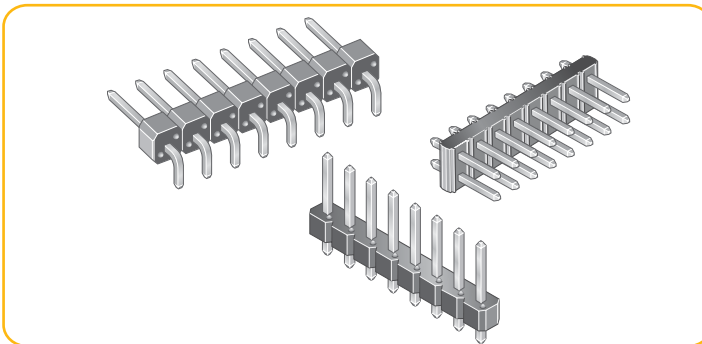

Minitek Active Latch

A latching crimp-to-wire system for demanding environments
Pages 64, 74

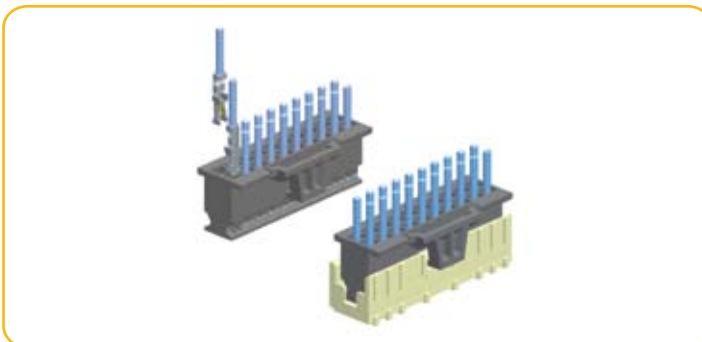

Minitek Eject Latch Header

This ribbon cable connector mates securely, but can be unmated with no difficulty.
Pages 70, 76



The Minitek 2mm Modular System

Now the most complete and versatile system available: intermateable, high temperature compatible, low coplanarity and space saving
Pages 52 – 76

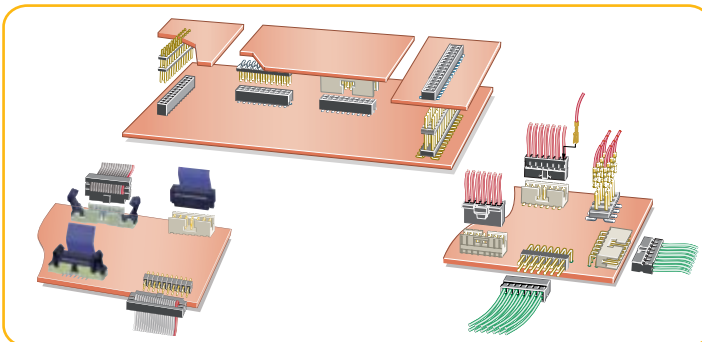

BOARD-TO-BOARD SOLUTIONS

PARALLEL

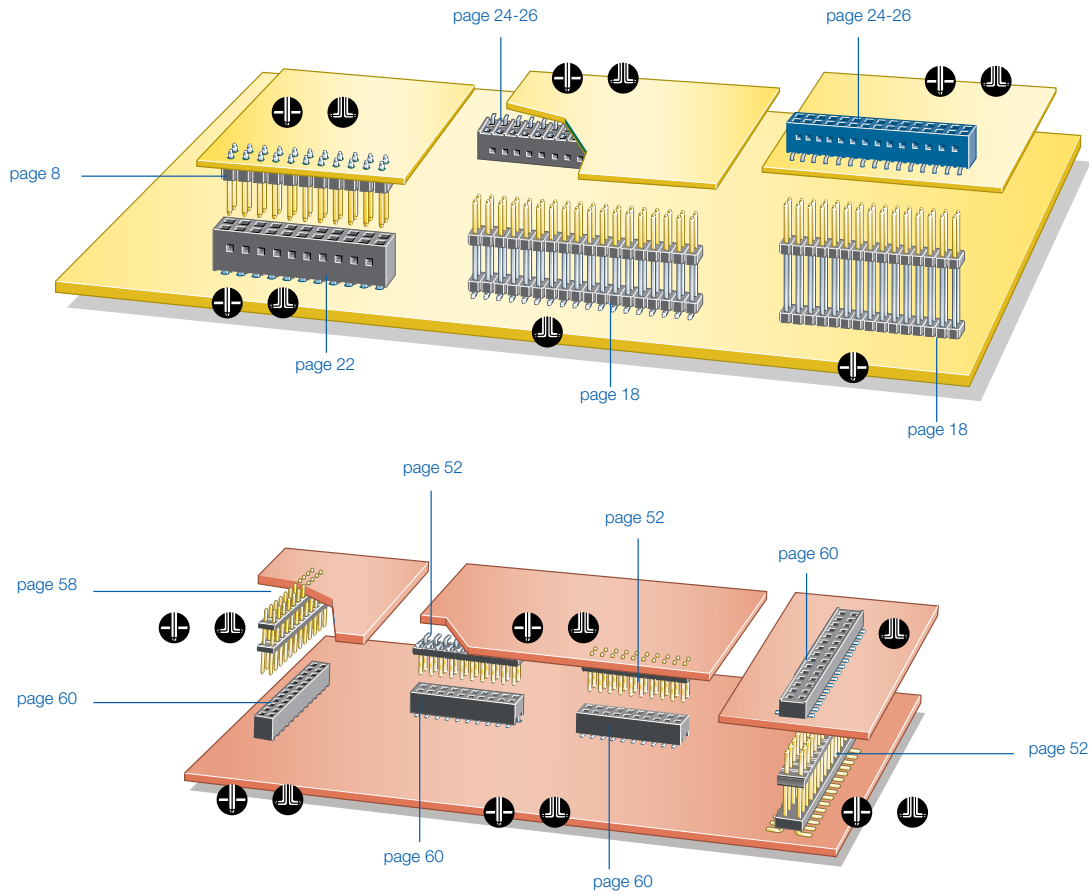

PERPENDICULAR

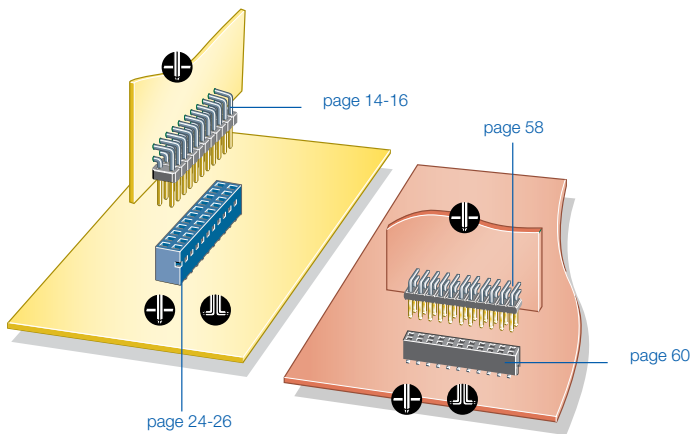

PLANAR

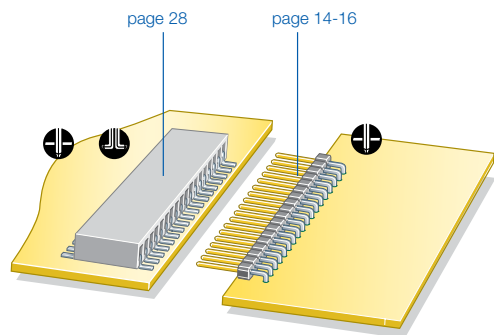

- = 2.54 mm
- = 2.00 mm
- = Through Mount
- = Surface Mount

CABLE-TO-BOARD SOLUTIONS

FLAT CABLE IDC

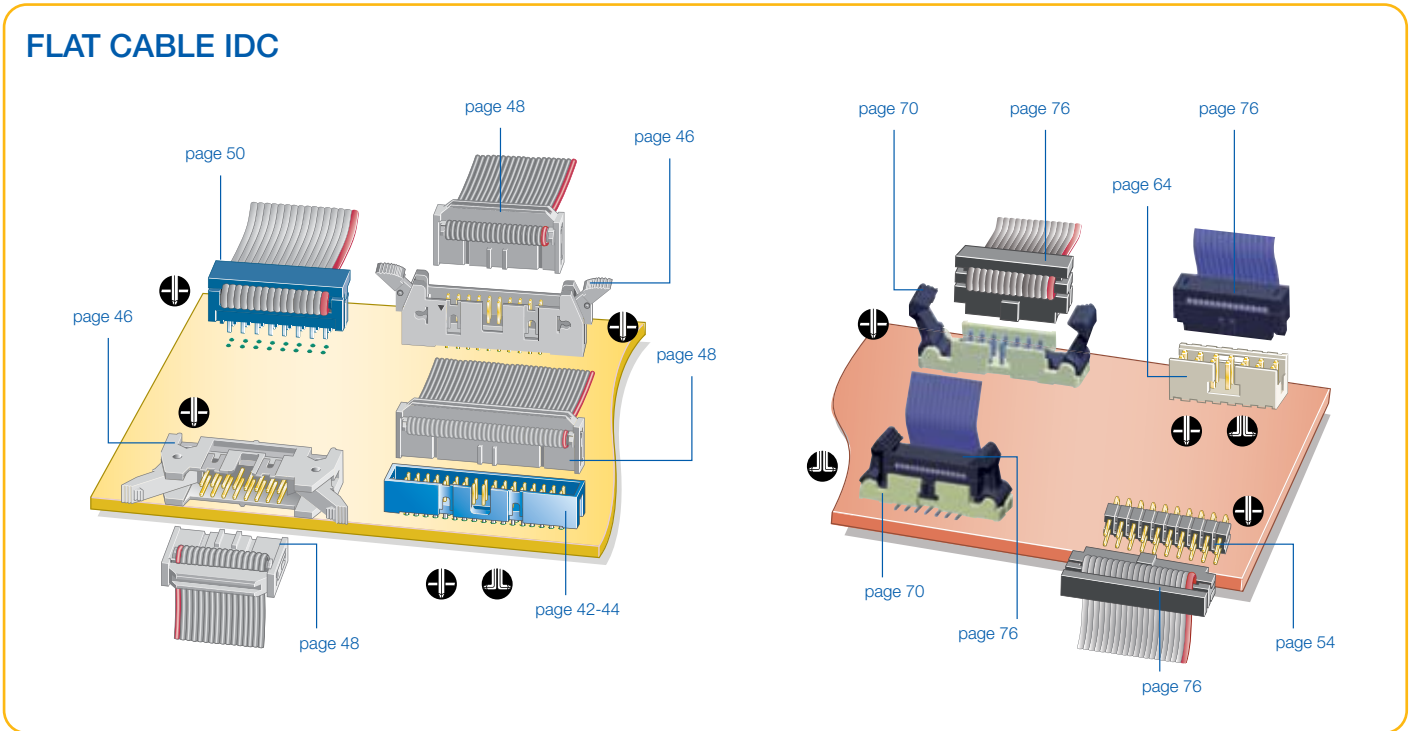

WIRE-TO-BOARD SOLUTIONS

DISCRETE WIRE

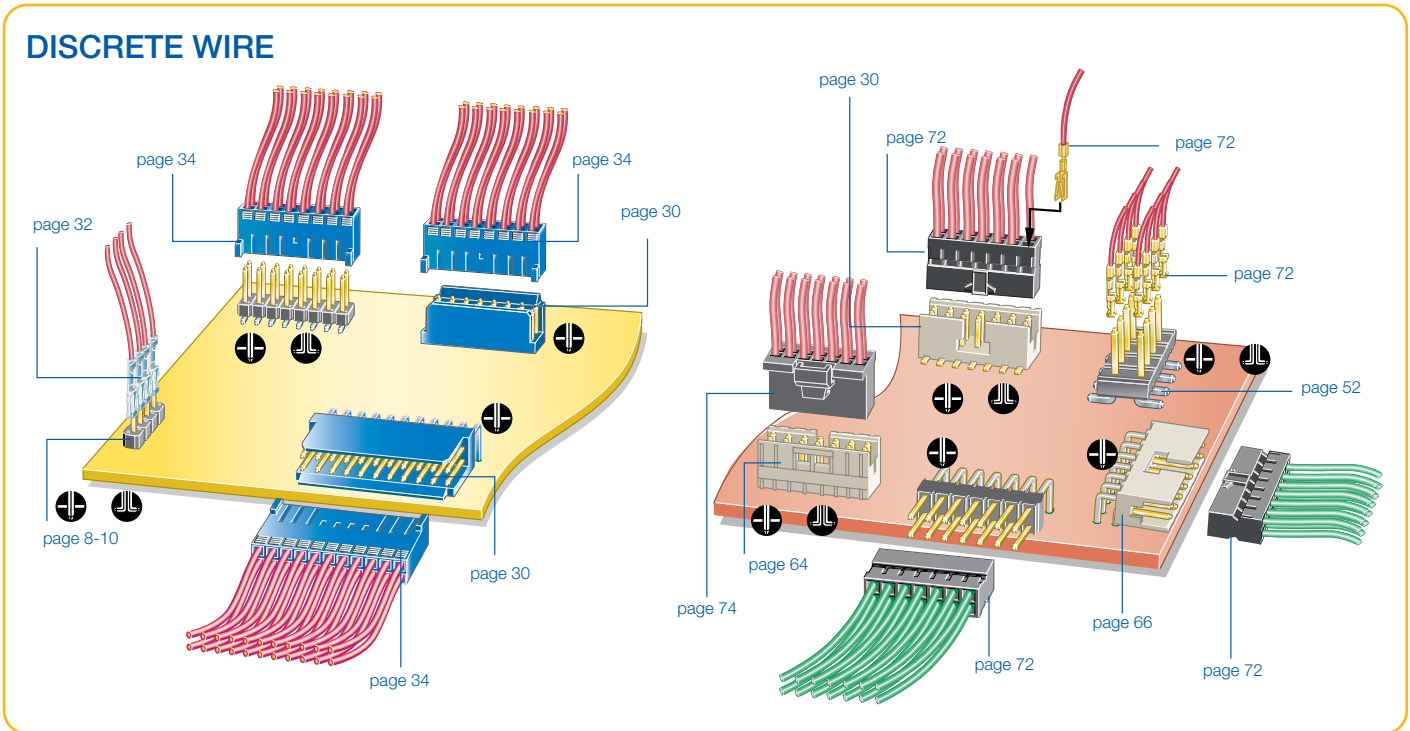

- = 2.54 mm
- = 2.00 mm
- = Through Mount
- = Surface Mount

2.54 mm (.100")

TECHNICAL DATA

PHYSICAL

- Housing: High temperature, black thermoplastic
- Flammability rating: UL 94 V-0
- Pin: Phosphor-bronze
- Plating: Gold or tin over 1.27 μm (50 μ") nickel

ELECTRICAL PERFORMANCE

- Current rating: 3 A continuous
- Insulation resistance: 5000 MΩ min.
- Dielectric withstanding voltage: 1500 V

MECHANICAL PERFORMANCE

- Pin retention to housing: 9 N min.



OPERATING TEMPERATURE RANGE

- -65°C to +125°C

PACKAGING

- Standard: Bags
- Optional: Tubes or
Tape-and-reel with pick-up cap
(SMT pin style 01 only)

REFERENCE INFORMATION

-  File no. E66906
-  File no. LR46923
- Product drawing: By 5-digit base part number
- Product specification: BUS-12-114
- Tape and Reel packaging data: TA-840

PROCESSING INFORMATION

- Compatible with wave, vapor-phase, and (for SMT) IR reflow soldering processes
- Recommended IR profile TA 842 for SMT

RoHs INFORMATION

- This product is RoHs compatible according to the European Union Directive 2002/95/IEC

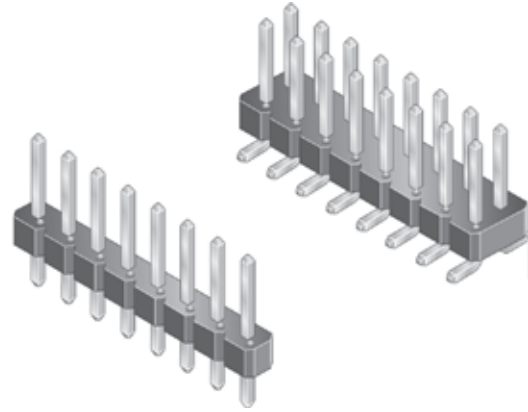

MATING DATA

■ Dubox™ Crimp-to-wire contacts	32
■ Dubox™ Crimp-to-wire housings	34
■ Dubox™ Vertical receptacles	22
■ Dubox™ Low profile vertical receptacles	24, 26
■ Dubox™ Horizontal receptacles	28
■ Quickie™ IDC receptacles	48
■ PV™ Crimp-to-Wire Contacts	38
■ PV™ Crimp-to-Wire Housings	40

TYPICAL APPLICATIONS

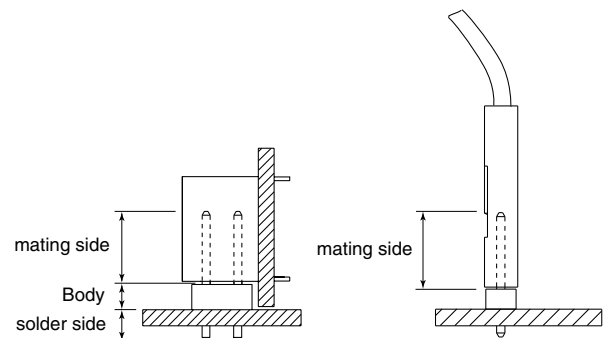

BergStik® Unshrouded Header, Vertical, Standard Sizes

2.54 mm (.100")

PART NUMBERS



Through mount
77311 = Single Row
77313 = Double Row

Surface mount
95293 = Single Row
95278 = Double Row

02 to 36 = Single row TMT
03 to 17 = Single Row SMT
04 to 72 = Double row TMT
04 to 50 = Double Row SMT
08 to 50 = Double Row SMT with pegs

Surface mount		Through mount			
Pin style	Mating	Pin style	Mating	Solder	overall length (OAL)
01	5.84	01	5.84	2.41	10.80
02	8.08	18	5.84	3.05	11.43
		02	5.84	3.42	11.80
		27	6.60	2.66	11.82
		22	7.75	3.06	13.35
		24	6.75	2.90	12.20

Option	Packaging
-	Plastic bag
A	Tape-and-reel with pick-up cap*
B	Tube with pick-up cap
	availability on request

1 = 0.76 µm (30µ")gold/GXT on mating area, tin on solder side
4 = tin
8 = 0.38 µm (15µ")gold/GXT on mating area, tin on solder side

77311	-	101	-	XXLF
77311	-	118	-	XXLF
77311	-	124	-	XXLF
77313	-	101	-	XXLF
77313	-	118	-	XXLF
77313	-	124	-	XXLF
95278	-	101	A	XXLF

CORE RANGE

XX = 04, 06, 08, 10, 12, 16, 20

* as available

PRODUCT

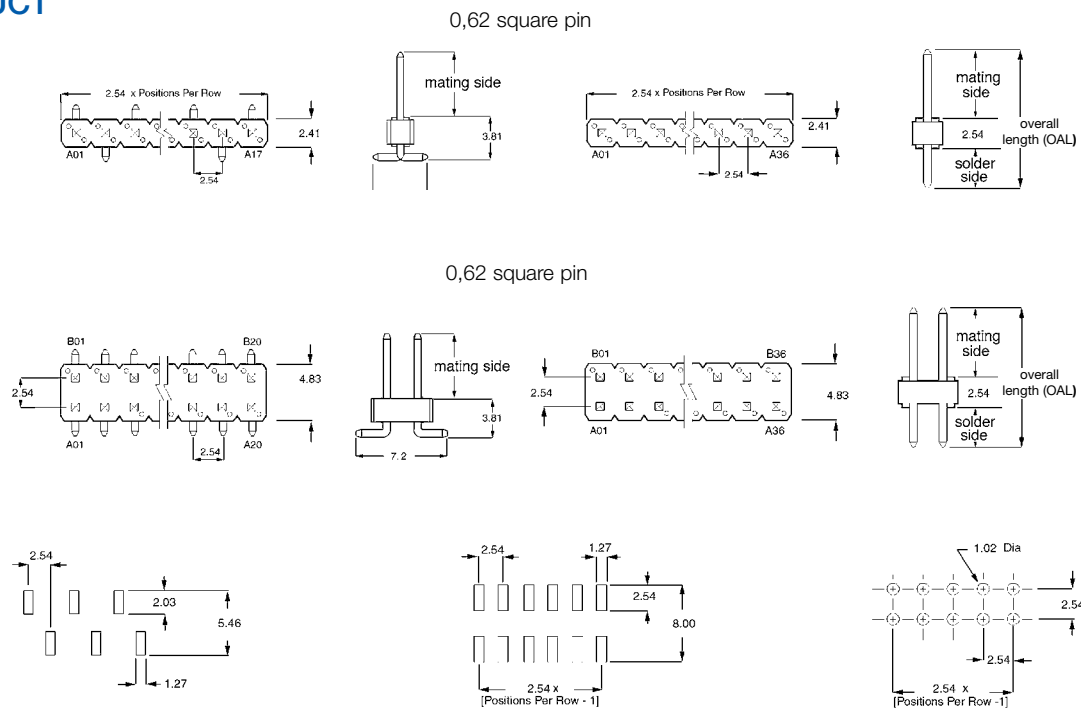

Dimension in mm

2.54 mm (.100")

TECHNICAL DATA

PHYSICAL

- Housing: High temperature, black thermoplastic
- Flammability rating: UL 94 V-0
- Pin: Phosphor-bronze
- Plating: Gold or tin over 1.27 µm (50 µ") nickel



ELECTRICAL PERFORMANCE

- Current rating: 3 A continuous
- Insulation resistance: 5000 MΩ min.
- Dielectric withstanding voltage: 1500 V

MECHANICAL PERFORMANCE

- Pin retention to housing: 9 N min.
- Retentive leg insertion force: >44.48 N max.
- Retentive leg board retention: 2.22 N

OPERATING TEMPERATURE RANGE

- -65°C to +125°C

PACKAGING

- Standard: Bags
- Optional: Tubes or Tape-and-reel with pick-up cap (SMT pin style 01 only)

REFERENCE INFORMATION

- File no. E66906
- File no. LR46923
- Product drawing: By 5-digit base part number
- Product specification: BUS-12-114

PROCESSING INFORMATION

- Compatible with wave, vapor-phase, and IR reflow soldering processes

RoHS INFORMATION

- This product is RoHS compatible according to the European Union Directive 2002/95/IEC

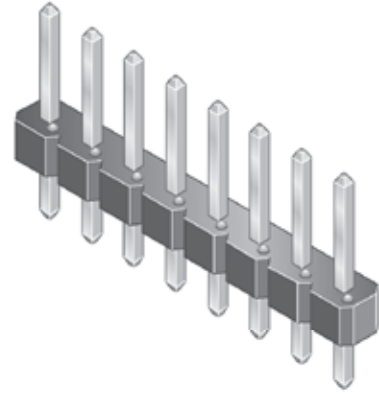

MATING DATA

■ Dubox™ Crimp-to-wire contacts	32
■ Dubox™ Crimp-to-wire housings	34
■ Dubox™ Vertical receptacles	22
■ Dubox™ Low profile vertical receptacles	24, 26
■ Dubox™ Horizontal receptacles	28
■ Quickie™ IDC receptacles	48
■ PV™ Crimp-to-Wire Contacts	38
■ PV™ Crimp-to-Wire Housings	40

TYPICAL APPLICATIONS

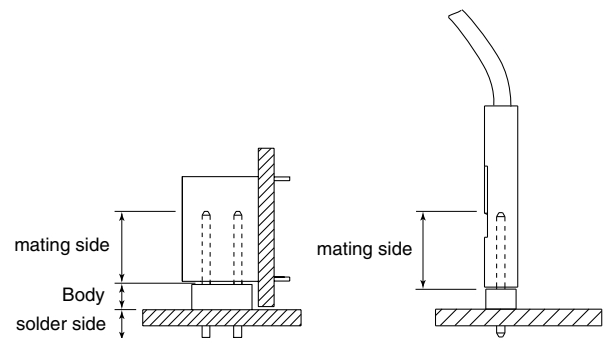

BergStik® Unshrouded Header, Vertical, Custom Sizes

2.54 mm (.100")

PART NUMBERS

Compile your own part number using custom dimensions (Please allow for initial setup on our system)

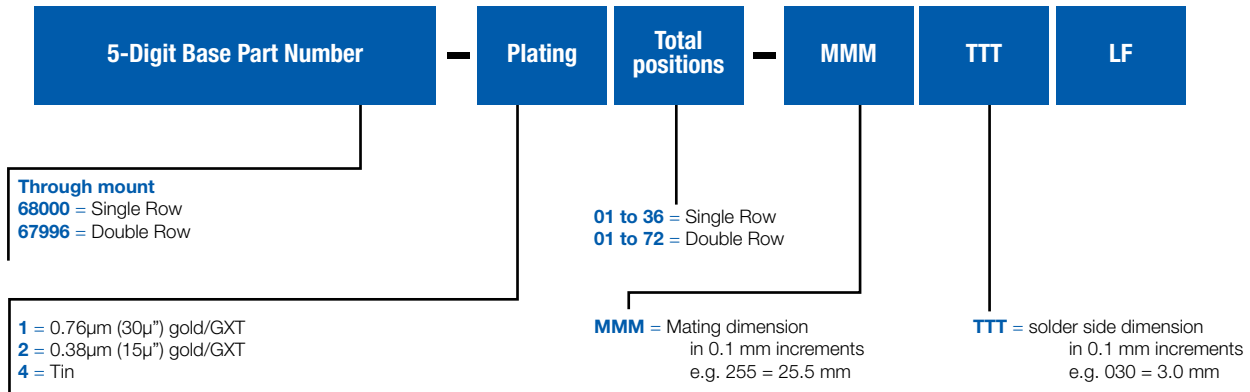

- Note:**
1. The total combined dimension for mating and solder side may not exceed 27 mm
 2. Standard packaging in bulk
 3. Special packaging availability upon request

PRODUCT

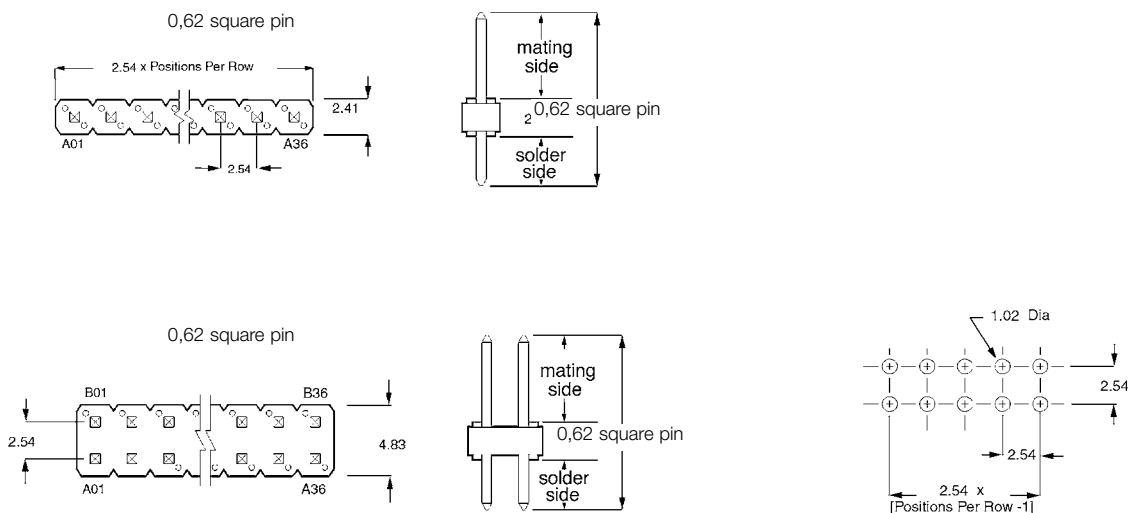

Recommended PCB layouts

Dimension in mm

2.54 mm (.100")

FEATURES

- Continuously molded and reeled
- High temperature plastic
- Various lengths cut from 1 part number
- Benchtop machine cuts, polarizes, and applies retentive leg

TECHNICAL DATA

PHYSICAL

- Housing: High temperature, black thermoplastic
- Flammability rating: UL 94 V-0
- Pin: Phosphor-bronze
- Plating: Gold or tin over 1.27 µm (50 µ") nickel



ELECTRICAL PERFORMANCE

- Current rating: 3 A continuous
- Insulation resistance: 5000 MΩ min.
- Dielectric withstanding voltage: 1500 V

MECHANICAL PERFORMANCE

- Pin retention to housing: 9 N min.

OPERATING TEMPERATURE RANGE

- 65°C to +125°C

PACKAGING

- Reel

REFERENCE INFORMATION

- File no. E66906
- File no. LR46923
- Product drawing: 54101 or 54102
- Product specification: BUS-12-059

PROCESSING INFORMATION

- Compatible with wave, vapor-phase, and IR reflow soldering processes

RoHs INFORMATION

- This product is RoHs compatible according to the European Union Directive 2002/95/IEC



MATING DATA

■ Dubox™ Crimp-to-wire contacts	32
■ Dubox™ Crimp-to-wire housings	34
■ Dubox™ Vertical receptacles	22
■ Dubox™ Low profile vertical receptacles	24, 26
■ Dubox™ Horizontal receptacles	28
■ Quickie™ IDC receptacles	48
■ PV™ Crimp-to-Wire Contacts	38
■ PV™ Crimp-to-Wire Housings	40

TYPICAL APPLICATIONS

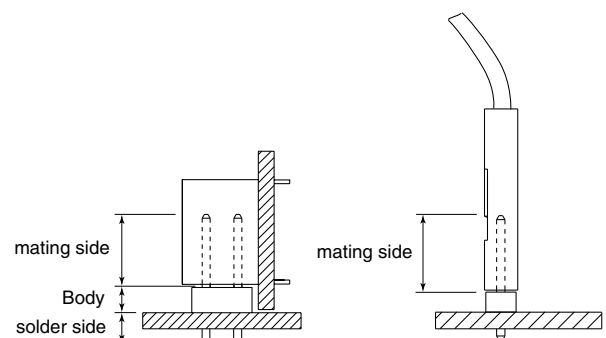

BergStik® Unshrouded Header, Continuous

2.54 mm (.100")

PART NUMBERS



Through mount
77311 = Single Row
77313 = Double Row

1 = 0.76µm (30µ") gold/GXT on mating area, tin on solder side
4 = tin
8 = 0.38µm (15µ") gold/GXT on mating area, tin on solder side

Pin Style	mating length	solder length	overall length (OAL)
01	5.84	2.41	10.80
18	5.84	3.05	11.43
02	5.84	3.42	11.80
27	6.60	2.66	11.82
22	7.75	3.06	13.35
24	6.75	2.90	12.20

PRODUCT

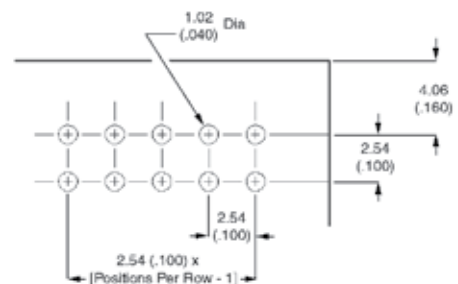
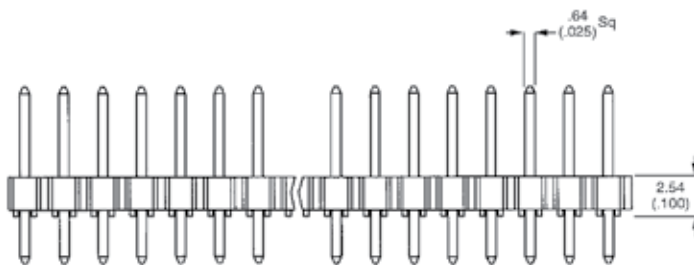
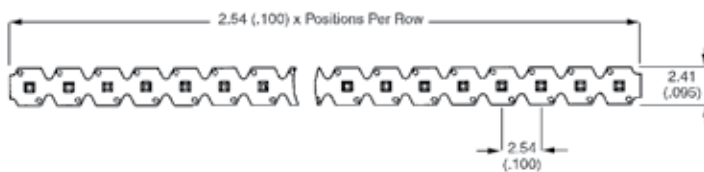

Recommended PCB layouts

Dimension in mm

2.54 mm (.100")

FEATURES

- High temperature plastic
- Selective plating

TECHNICAL DATA

PHYSICAL

- Housing: High temperature, black thermoplastic
- Flammability rating: UL 94 V-0
- Pin: Phosphor-bronze
- Plating: Gold or tin over 1.27 µm (50 µ") nickel



ELECTRICAL PERFORMANCE

- Current rating: 3 A continuous
- Insulation resistance: 5000 MΩ min.
- Dielectric withstanding voltage: 1500 V

MECHANICAL PERFORMANCE

- Pin retention to housing: 9 N min.

OPERATING TEMPERATURE RANGE

- 65°C to +125°C

PACKAGING

- Bags

REFERENCE INFORMATION

- File no. E66906
- File no. LR46923
- Product drawing: By 5-digit base part number
- Product specification: BUS-12-114

PROCESSING INFORMATION

- Compatible with wave, vapor-phase, and IR reflow soldering processes

RoHs INFORMATION

- This product is RoHs compatible according to the European Union Directive 2002/95/IEC

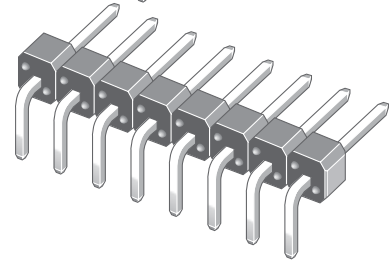
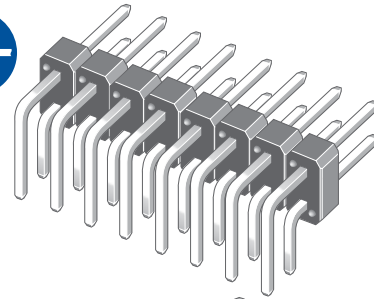

MATING DATA

■ Dubox™ Crimp-to-wire contacts	32
■ Dubox™ Crimp-to-wire housings	34
■ Dubox™ Vertical receptacles	22
■ Dubox™ Low profile vertical receptacles	24, 26
■ Dubox™ Horizontal receptacles	28
■ Quickie™ IDC receptacles	48
■ PV™ Crimp-to-Wire Contacts	38
■ PV™ Crimp-to-Wire Housings	40

TYPICAL APPLICATIONS

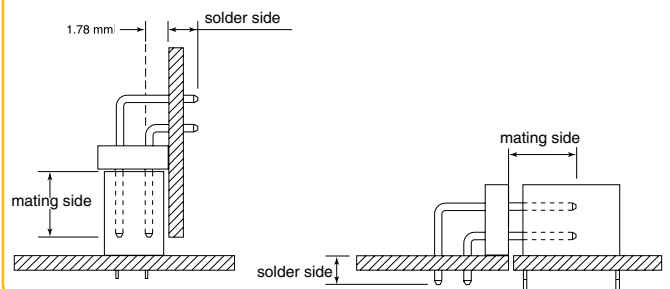
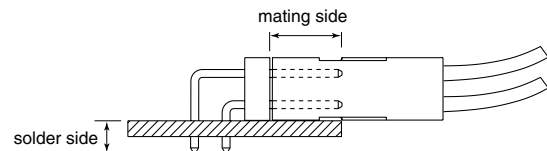

BergStik® Unshrouded Header, Right Angle, Standard Sizes

2.54 mm (.100")

PART NUMBERS



Through mount
77315 = Single Row
77317 = Double Row

02 to 36 = Single row TMT
04 to 72 = Double row TMT

Pin style		Mating	Solder
77315	77317		
01	03	5.84	2.41
18	04	5.84	3.05
24	12	6.75	2.90

1 = 0.76 µm (30µ") gold/GXT on mating area, tin on solder side
4 = tin
8 = 0.38 µm (15µ") gold/GXT on mating area, tin on solder side

PRODUCT

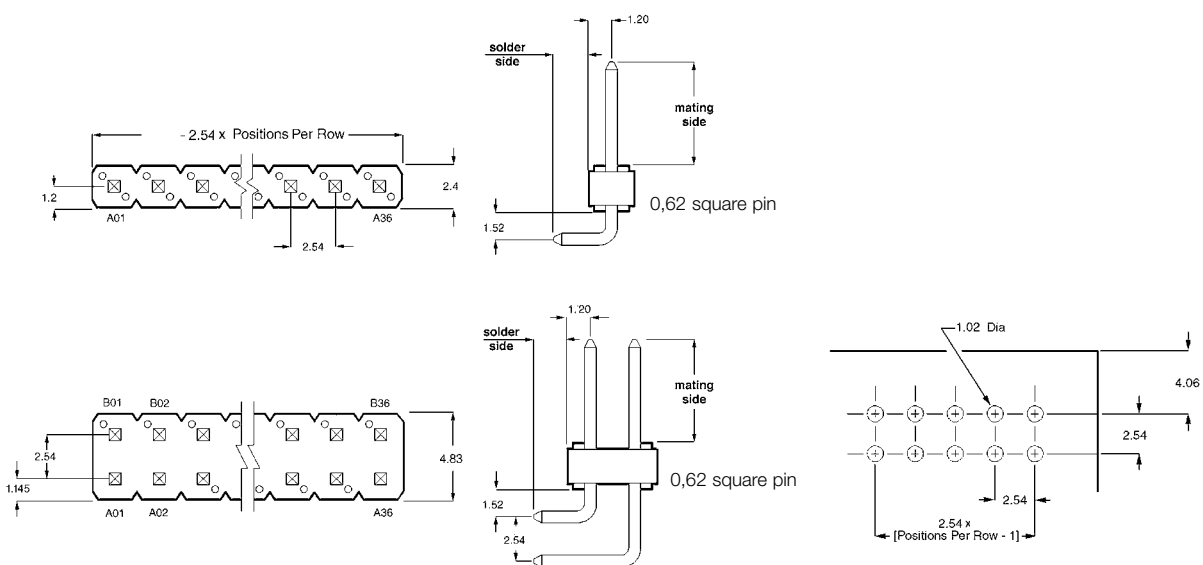

Recommended PCB layouts

Dimension in mm

2.54 mm (.100")

TECHNICAL DATA

PHYSICAL

- Housing: High temperature, black thermoplastic
- Flammability rating: UL 94 V-0
- Pin: Phosphor-bronze
- Plating: Gold or tin over 1.27 µm (50 µ") nickel



ELECTRICAL PERFORMANCE

- Current rating: 3 A continuous
- Insulation resistance: 5000 MΩ min.
- Dielectric withstanding voltage: 1500 V

MECHANICAL PERFORMANCE

- Pin retention to housing: 9 N min.
- Retentive leg insertion force: >44.48 N max.
- Retentive leg board retention: 2.22 N

OPERATING TEMPERATURE RANGE

- -65°C to +125°C

PACKAGING

- Bags

REFERENCE INFORMATION

- File no. E66906
- File no. LR46923
- Product drawing: 55101 or 55102
- Product specification: BUS-12-114

PROCESSING INFORMATION

- Compatible with wave, vapor-phase, and IR reflow soldering processes

RoHs INFORMATION

- This product is RoHs compatible according to the European Union Directive 2002/95/IEC

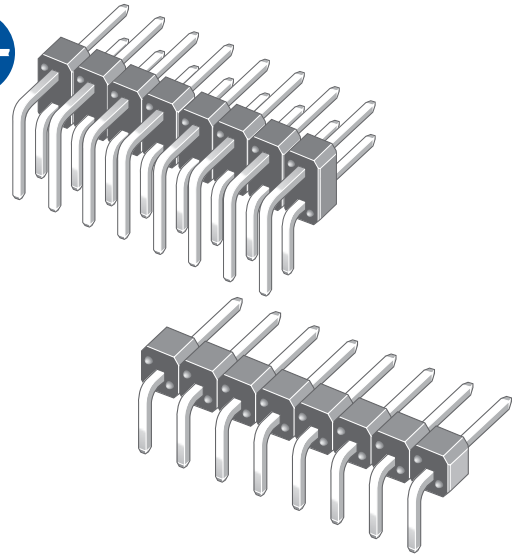

MATING DATA

■ Dubox™ Crimp-to-wire contacts	32
■ Dubox™ Crimp-to-wire housings	34
■ Dubox™ Vertical receptacles	22
■ Dubox™ Low profile vertical receptacles	24, 26
■ Dubox™ Horizontal receptacles	28
■ Quickie™ IDC receptacles	48
■ PV™ Crimp-to-Wire Contacts	38
■ PV™ Crimp-to-Wire Housings	40

TYPICAL APPLICATIONS

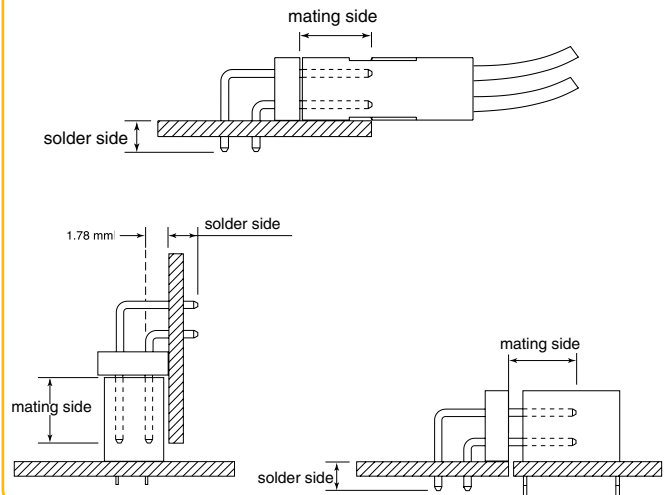

BergStik® Unshrouded Header, Right Angle, Custom Sizes

2.54 mm (.100")

PART NUMBERS

Compile your own part number using custom dimensions (Please allow for initial setup on our system)

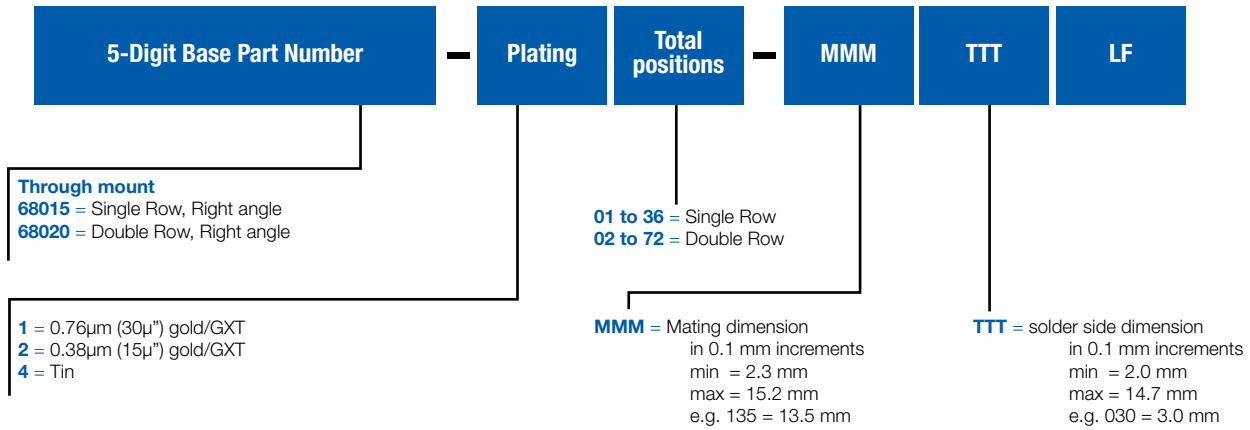

- Note:**
1. Bend dimension 1.52 mm only
 2. The total combined dimension for mating and solder side may not exceed 25,5 mm

PRODUCT

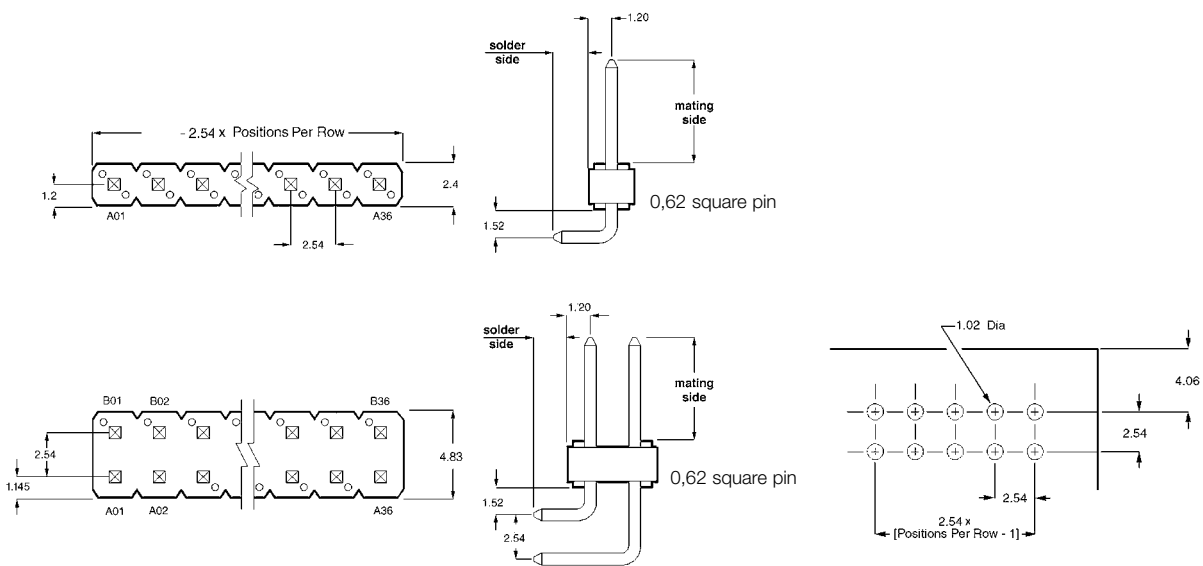

Dimension in mm

Recommended PCB layouts

2.54 mm (.100")

FEATURES

- Wide variety of stack heights in 0.5 mm increments
- High temperature plastic
- Selective plating

TECHNICAL DATA

PHYSICAL

- Housing: High temperature, black thermoplastic
- Flammability rating: UL 94 V-0
- Pin: Phosphor-bronze
- Plating: Gold or tin over 1.27 μm (50 μ") nickel



ELECTRICAL PERFORMANCE

- Current rating: 3 A continuous
- Insulation resistance: 5000 MΩ min.
- Dielectric withstanding voltage: 1500 V

MECHANICAL PERFORMANCE

- Pin retention to housing: 9 N min.

OPERATING TEMPERATURE RANGE

- 65°C to +125°C

PACKAGING

- Bags

REFERENCE INFORMATION

- File no. E66906
- File no. LR46923
- Product drawing: By 5-digit base part number
- Product specification: BUS-12-114

PROCESSING INFORMATION

- Compatible with wave, vapor-phase, and IR reflow soldering processes

RoHs INFORMATION

- This product is RoHs compatible according to the European Union Directive 2002/95/IEC

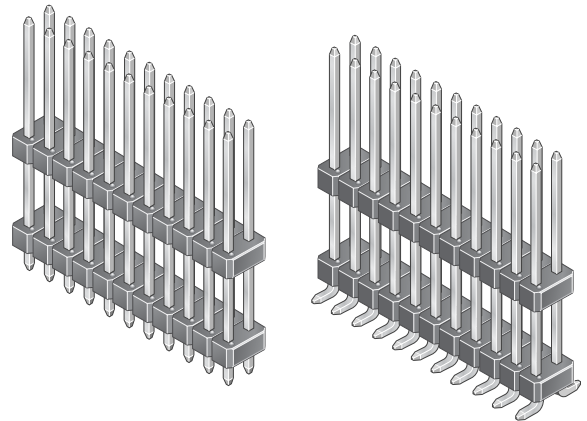

MATING DATA

- Dubox™ Vertical receptacles 22
- Dubox™ Low profile vertical receptacles 24, 26

TYPICAL APPLICATIONS

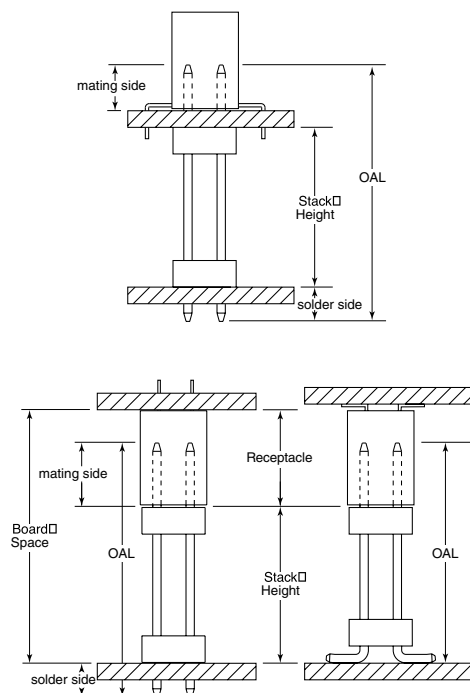

BergStik® Unshrouded Header, Stacking

2.54 mm (.100")

PART NUMBERS

Compile your own part number using custom dimensions (Please allow for initial setup on our system)



1 = Through Hole (TMT)
2 = Surface Mount (SMT)

1 = Single Row (TMT only)
2 = Double Row

1 = 2.41 mm
2 = 3.05 mm
4 = SMT (double row only)

1 = 0.76 μm (30μ") gold/GXT on mating area, tin on solder side
8 = 0.38 μm (15μ") gold/GXT on mating area, tin on solder side

02 to 36 single row (TMT)
04 to 72 double row (TMT)
04 to 50 double row (SMT)

Pin Style	Overall length (TMT) mm	Overall length (SMT) mm
01	12.20	10.42
02	13.50	11.72
03	15.90	14.12
04	16.76	14.98
05	17.65	15.87
06	18.91	17.13
07	20.96	19.18
08	23.50	21.72
09	26.04	24.26
10	28.58	26.80
11	31.12	29.34
12	33.66	31.88

XX.XX = mm

Specify mm

i.e. 08.50 = 8.50 mm
in 0.50 mm increments

TMT = 08.00 min. - 25.00 max.

SMT = 09.50 min. - 26.00 max.

PRODUCT

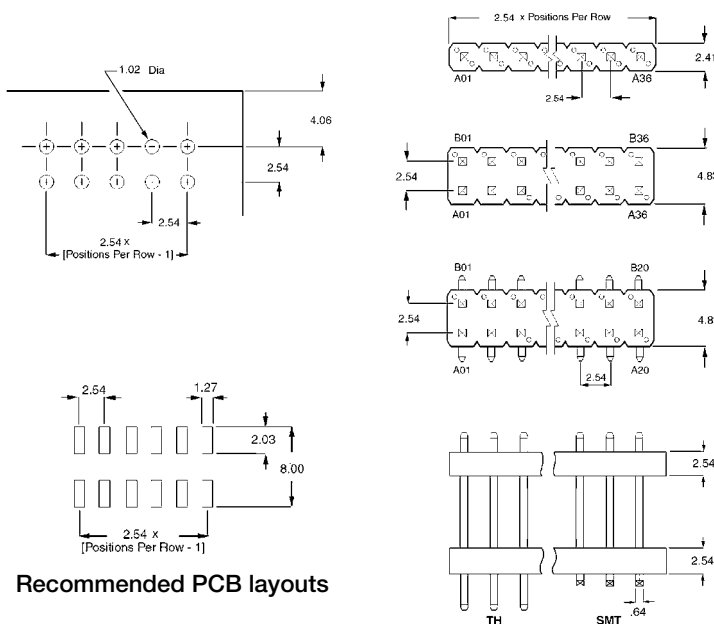

Recommended PCB layouts

The board spacing

is the stack height of this header, plus the height of the receptacle (see application drawings on opposite page)

Dimension in mm

2.54 mm (.100")

FEATURES

- Dual-beam contacts for added reliability
- Slotted cutout in low profile housing simplifies electrical testing
- Side-by-side and end-to-end stackable

TECHNICAL DATA

PHYSICAL

- Housing: Black thermoplastic
- Flammability rating: UL 94 V-0
- Contact: Phosphor-bronze
- Plating: Gold or tin over 1.27 µm (50 µ") nickel



low profile only

ELECTRICAL PERFORMANCE

- Current rating: 2.5 A max. per contact
- Insulation resistance: 50,000 MΩ min.
- Contact resistance: 15 MΩ max. initial, 20 MΩ max. after environmental tests

Dielectric withstanding voltage: 800 V

MECHANICAL PERFORMANCE

- Mating cycles (durability): 50-Gold, 25-Tin.
- Insertion force: 450 gf max. per gold contact
500 gf max. per tin-lead contact
- Withdrawal force: 30 gf min. per gold contact
30 gf min. per tin-lead contact.

OPERATING TEMPERATURE RANGE

- -65°C to +125°C

PACKAGING

- Plastic bags

REFERENCE INFORMATION

- File no. E66906
- File no. LR46923
- Product drawing: By 5-digit base part number
- Product specification: BUS-12-071-gold
BUS-12-070-tin

RoHs INFORMATION

- This product is RoHs compatible according to the European Union Directive 2002/95/IEC

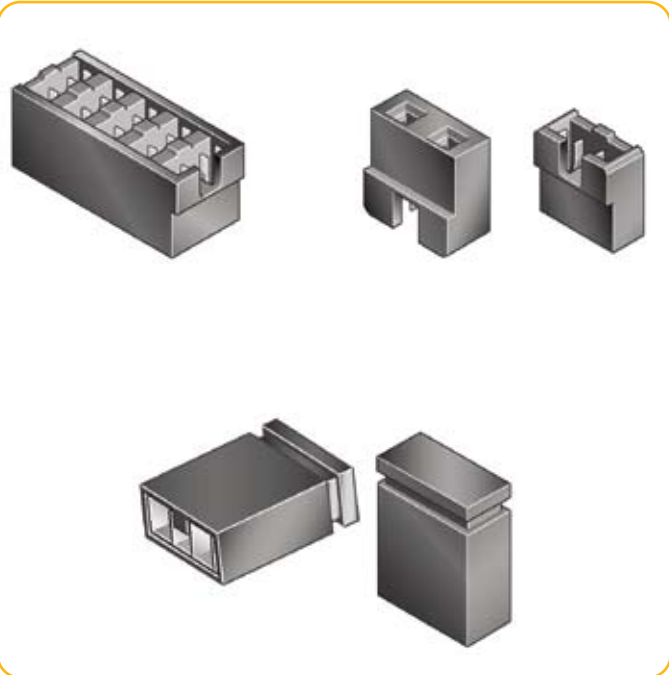

MATING DATA

- Continuous unshrouded headers 12
- Unshrouded vertical headers 8, 10
- Unshrouded right angle headers 1 14, 16

INSERTION DEPTH

- 4.85 mm (.191") min.
[provides 3.81 mm (.015") wipe] - Low profile

TYPICAL APPLICATIONS

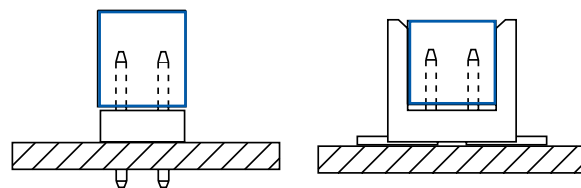

SHUNTS

2.54 mm (.100")

PART NUMBERS

Low profile



2 = 0.76 μm (30μ") gold
3 = tin

Standard



2 = 0.76 μm (30μ") gold
3 = tin

Multi-position



2 = 0.76 μm (30μ") gold
3 = tin
4 to 20 positions



PRODUCT

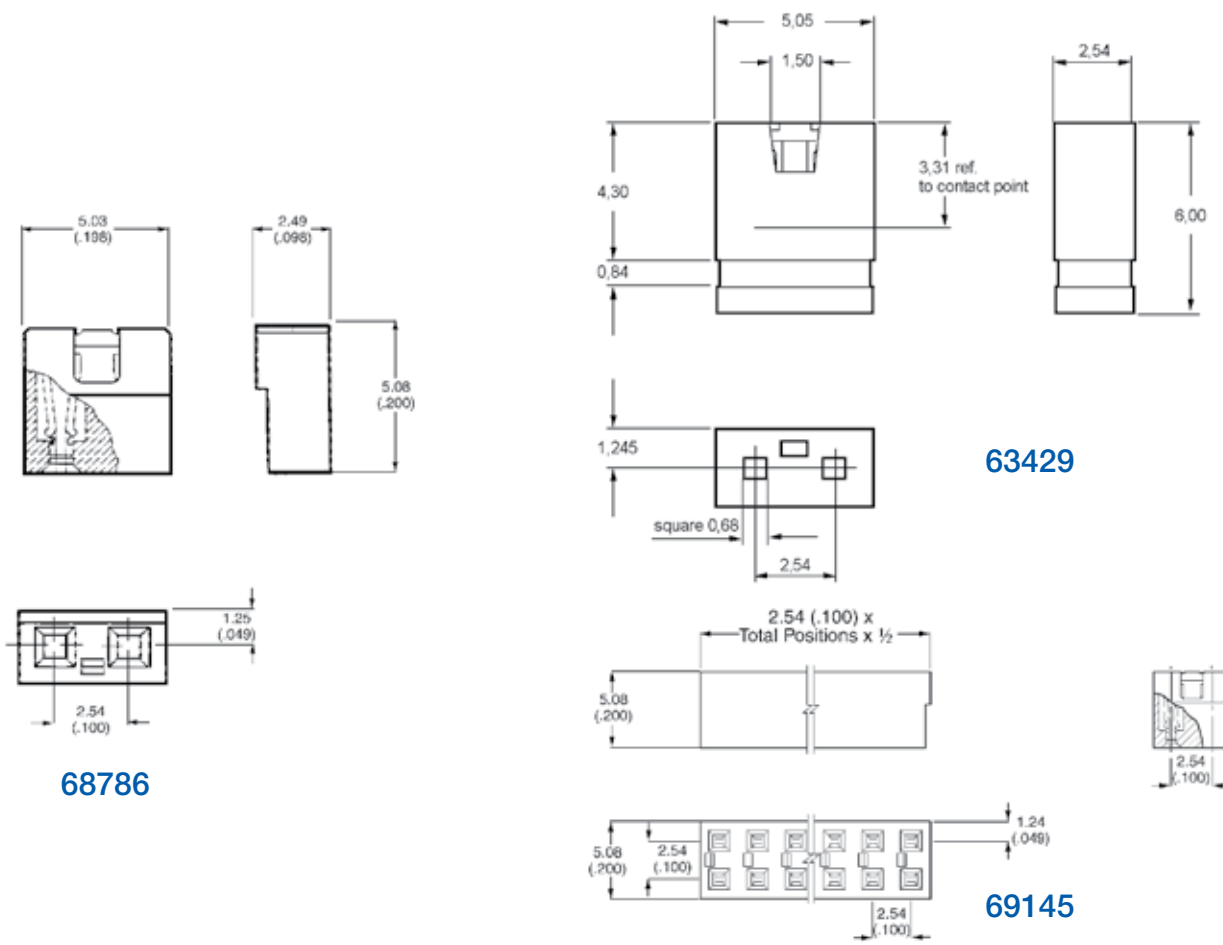

Dimension in mm

2.54 mm (.100")

FEATURES

- The Dubox™ contact has a pre-stressed, dual beam design to enable low insertion force
- 4-wall contact design for signal protection

TECHNICAL DATA

PHYSICAL

- Housing: Glass filled thermoplastic polyester, blue
- Flammability rating: UL 94 V-0
- Contact: Phosphor-bronze
- Plating: Gold or tin in accordance with IEC 603-81

ELECTRICAL PERFORMANCE

- Current rating: 3 A dc max. per individual contact
2 A dc max. per contact for fully energized connector
- Insulation resistance: 1×10^5 M Ω min.
- Contact resistance: 15 M Ω max. initial,
20 M Ω max. after environmental tests
- Dielectric withstanding voltage: 1000 V rms

MECHANICAL PERFORMANCE

- Mating cycles (durability): 200
- Insertion force per gold contact: 1.50 N (150 gf) max.
- Withdrawal force per gold contact: 0.30 N (30 gf) min.

OPERATING TEMPERATURE RANGE

- -65°C to +125°C



PACKAGING

- Plastic boxes or tubes

PROCESSING INFORMATION

- Compatible with wave soldering processes

REFERENCE INFORMATION

-  File no. E66906
-  File no. LR46923
- Product drawing: By 5-digit base part number
- Product specification: HE 13/14 and IEC 603-8

RoHs INFORMATION

- This product is RoHs compatible according to the European Union Directive 2002/95/IEC

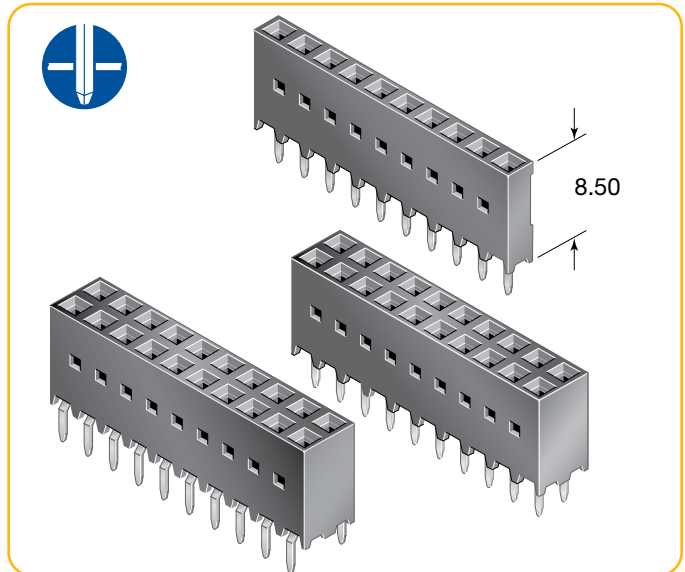

MATING DATA

- BergStik® Unshrouded vertical headers 8, 10
- BergStik® Unshrouded right angle headers 14, 16
- BergStik® Unshrouded stacking headers 18
- BergStik® continuous Unshrouded headers 12

INSERTION DEPTH

- Top Entry: 3.6 mm min. to 6.81 mm max.
[provides .381 mm wipe]
- Bottom Entry: 7 mm min.
[provides .381 mm wipe] plus board thickness

TYPICAL APPLICATIONS

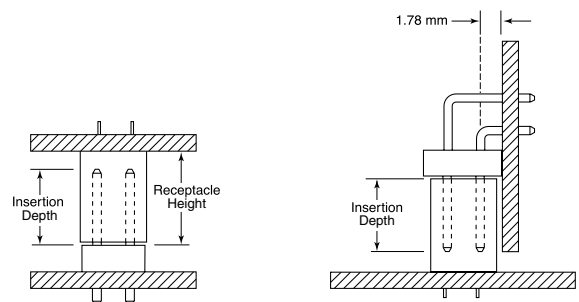

Dubox™ Vertical Receptacles

2.54 mm (.100")

PART NUMBERS

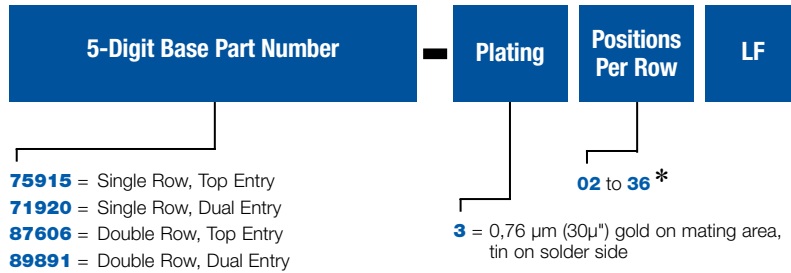

*Other sizes available on request

PRODUCT

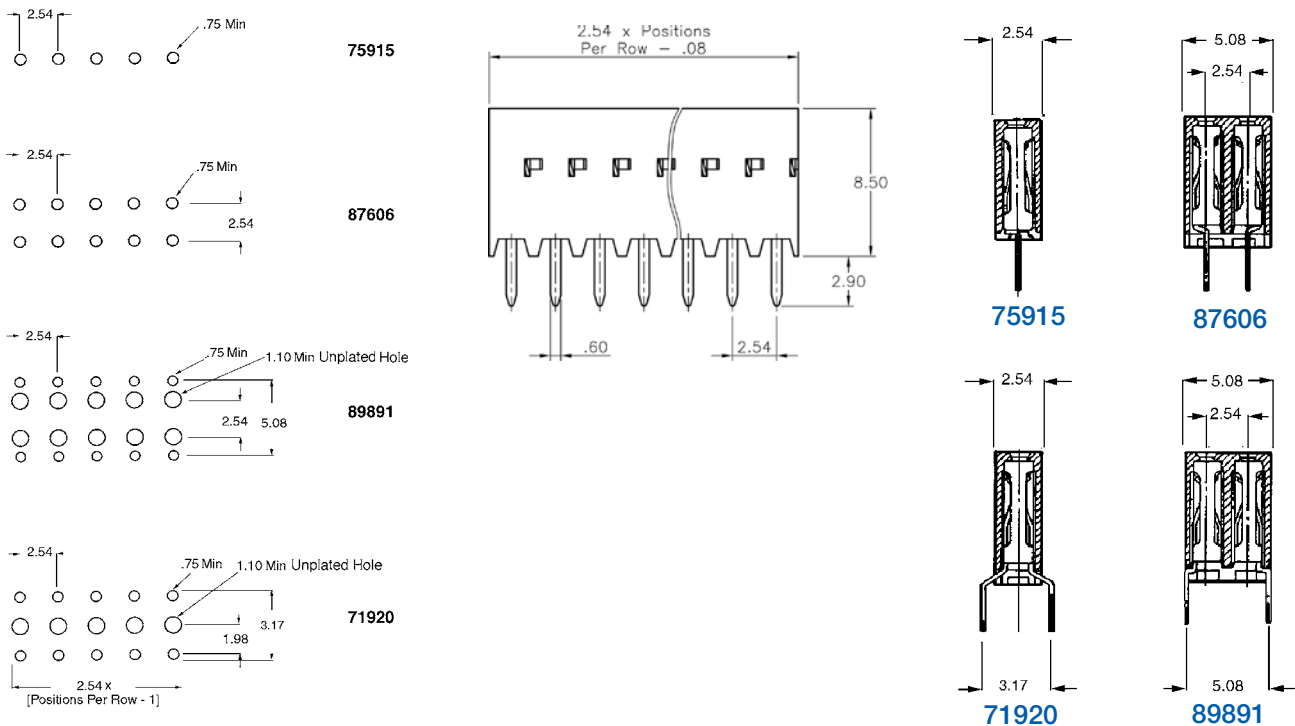

Recommended PCB layouts

Dimension in mm

2.54 mm (.100")

FEATURES

- The Dubox™ contact has a pre-stressed, dual beam design to enable low insertion force
- 4-wall contact design for signal protection

TECHNICAL DATA

PHYSICAL

- Housing: Glass filled thermoplastic polyester, blue
- Flammability rating: UL 94 V-0
- Contact: Phosphor-bronze
- Plating: Gold or tin over 1.27 µm (50 µ") nickel

ELECTRICAL PERFORMANCE

- Current rating: 3 A dc max. per individual contact
2 A dc max. per contact for fully energized connector
- Insulation resistance: 1x 10⁵ MΩ min.
- Contact resistance: 15 MΩ max. initial,
20 MΩ max. after environmental tests
- Dielectric withstanding voltage: 1000 V rms

MECHANICAL PERFORMANCE

- Mating cycles (durability): 200
- Insertion force per gold contact: 1.50 N (150 gf) max.
- Withdrawal force per gold contact: 0.30 N (30 gf) min.

OPERATING TEMPERATURE RANGE

- -65°C to +125°C



PACKAGING

- Plastic boxes or tubes

PROCESSING INFORMATION

- Compatible with wave soldering processes

REFERENCE INFORMATION

-  File no. E66906
-  File no. LR46923
- Product drawing: By 5-digit base part number
- Product specification: BUS-12-055

RoHS INFORMATION

- This product is RoHS compatible according to the European Union Directive 2002/95/IEC

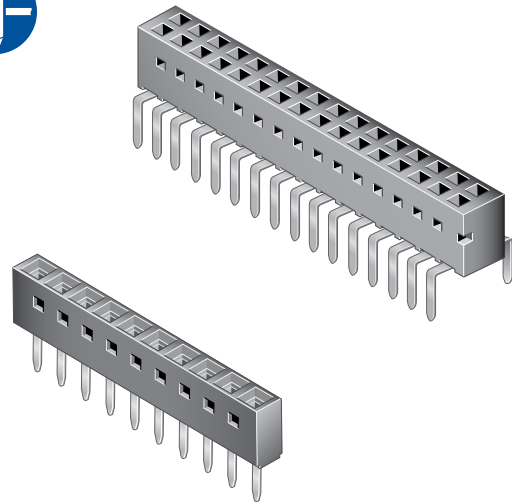

MATING DATA

- BergStik® Unshrouded vertical headers 8, 10
- BergStik® Unshrouded right angle headers 14, 16
- BergStik® Unshrouded stacking headers 18
- BergStik® continuous Unshrouded headers 12

INSERTION DEPTH

- Top Entry: 3.6 mm min. to 6.7 mm max.
[provides .381 mm wipe]
- Bottom Entry: 6 mm min.
[provides .381 mm wipe] plus board thickness

TYPICAL APPLICATIONS

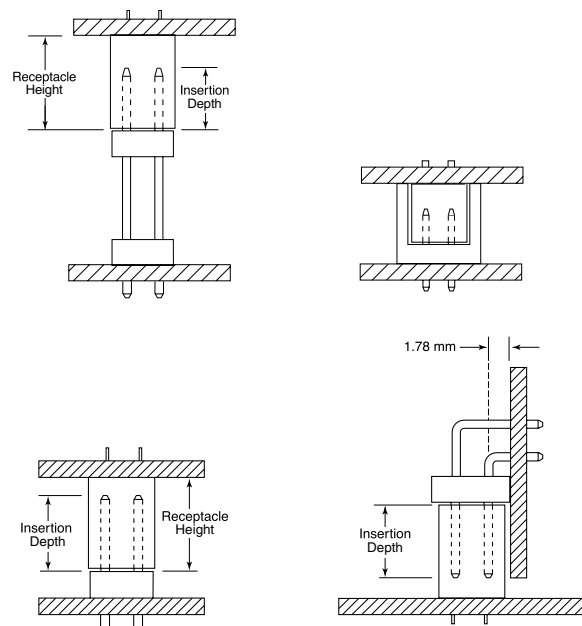

Dubox™ Vertical Receptacles, Low Profile

2.54 mm (.100")

PART NUMBERS

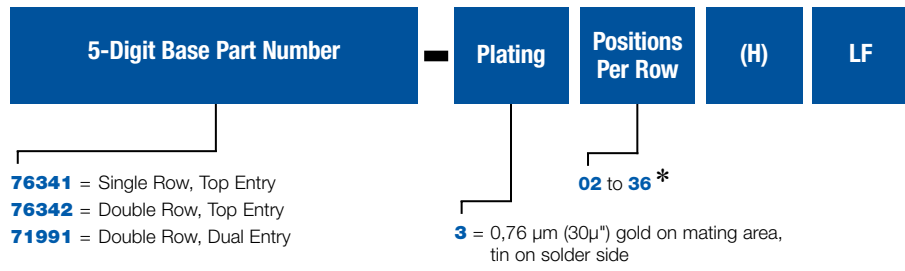

*Other sizes available on request

PRODUCT

P/N 76341
Top Entry

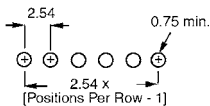

P/N 76342
Top Entry

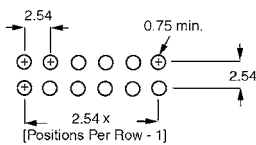

P/N 71991
Dual Entry

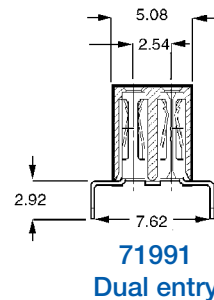
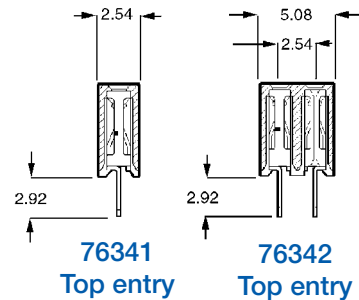
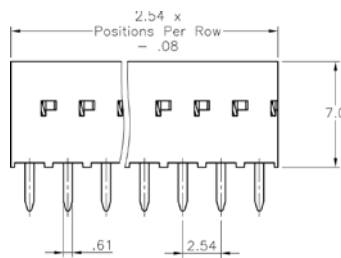
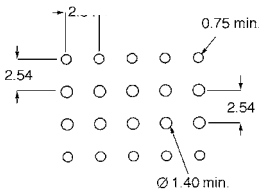

Recommended PCB layouts

Dimension in mm

2.54 mm (.100")

FEATURES

- The Dubox™ contact has a pre-stressed, dual beam design to enable low insertion force
- 4-wall contact design for signal protection

TECHNICAL DATA

PHYSICAL

- Housing: High temperature body, grey
- Flammability rating: UL 94 V-0
- Contact: Phosphor-bronze
- Plating: Gold or tin over 1.27 µm (50 µ") nickel



ELECTRICAL PERFORMANCE

- Current rating: 3 A dc max. per individual contact
2 A dc max. per contact for fully energized connector
- Insulation resistance: 1x 10⁵ MΩ min.
- Contact resistance: 15 MΩ max. initial,
20 MΩ max. after environmental tests
- Dielectric withstanding voltage: 1000 V rms

MECHANICAL PERFORMANCE

- Mating cycles (durability): 200
- Insertion force per gold contact: 1.50 N (150 gf) max.
- Withdrawal force per gold contact: 0.30 N (30 gf) min.

OPERATING TEMPERATURE RANGE

- -65°C to +125°C

PACKAGING

- Plastic boxes or tubes
- Tape and reel as available

PROCESSING INFORMATION

- Compatible with vapor-phase, and IR reflow soldering processes

REFERENCE INFORMATION

- File no. E66906
- File no. LR46923
- Product drawing: By 5-digit base part number
- Product specification: BUS-12-055

RoHS INFORMATION

- This product is RoHS compatible according to the European Union Directive 2002/95/IEC

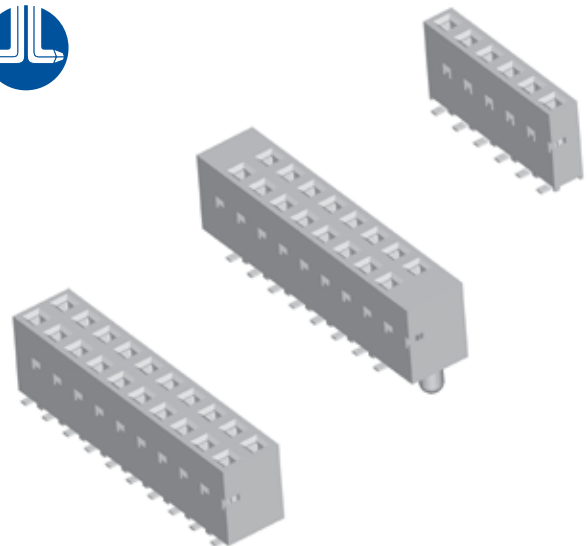

MATING DATA

- BergStik® Unshrouded vertical headers 8, 10
- BergStik® Unshrouded right angle headers 14, 16
- BergStik® Unshrouded stacking headers 18
- BergStik® continuous Unshrouded headers 12

INSERTION DEPTH

- Top Entry: 3.6 mm min. to 6.7 mm max.
[provides .381 mm wipe]
- Bottom Entry: 6 mm min.
[provides .381 mm wipe] plus board thickness

TYPICAL APPLICATIONS

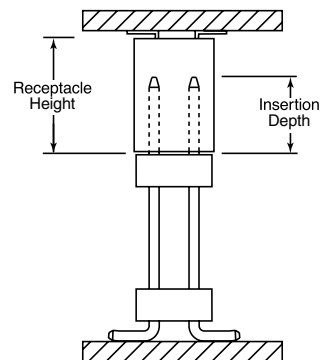

Dubox™ Vertical Receptacles, Low Profile

2.54 mm (.100")

PART NUMBERS



- 91601** = Single Row, Dual Entry
- 91614** = Single Row with external Locating Pegs, Dual Entry
- 89898** = Double Row, Dual Entry
- 91615** = Double Row with External Locating Pegs, Dual Entry
- 91618** = Double Row with Internal Locating Pegs, Dual Entry

- = standard-tubes
A = Tape-and-Reel packaging with pick-up cap *

02 to 25 Single Row
02 to 25 Double Row

3 = 0,76 µm (30µ") gold on mating area, tin on solder side

89898 - 3XXALF

XX = 02, 03, 04, 05, 06, 08, 10

* as available

PRODUCT

Standard

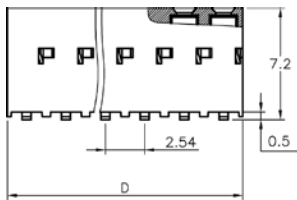

External Locating Pegs

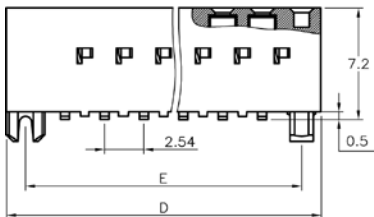

Internal Locating Pegs

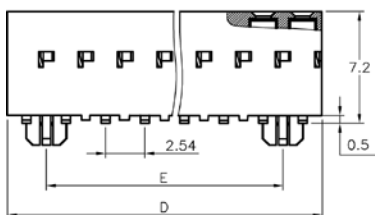

Dimension in mm

Single Row + Pad lay-outs

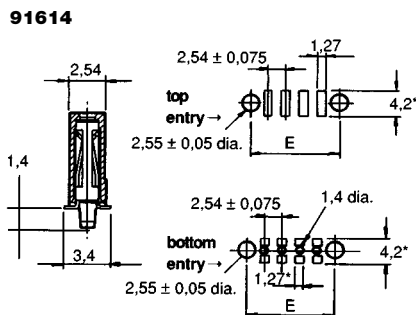
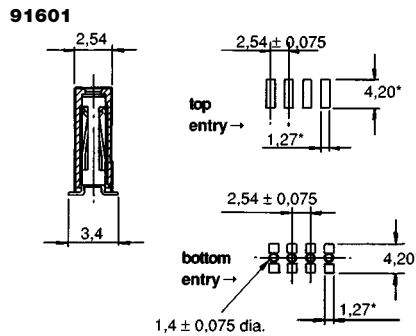

*Note: available as of 3 position versions

not available in single row

Note:
All dimensions marked with *
are minimum dimensions

Double Row + Pad lay-outs

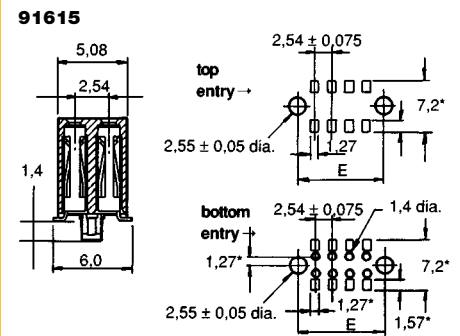
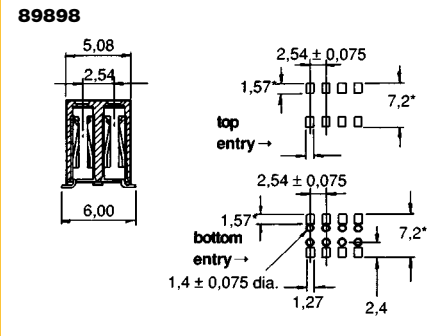

*Note: available as of 3 position versions

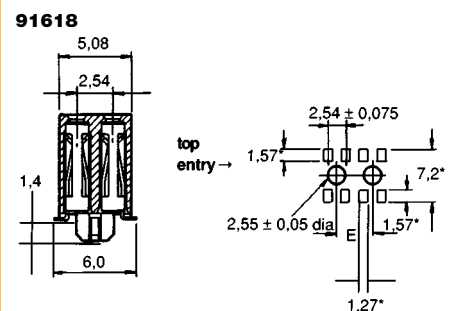

*Note: available as of 6 number of positions

2.54 mm (.100")

FEATURES

- The Dubox™ contact has a pre-stressed, dual beam design to enable low insertion force
- Floating solder tails self-center on circuit pads and assure coplanarity
- 4-wall contact design for signal protection

TECHNICAL DATA

PHYSICAL

- Housing: Blue thermoplastic -Through hole
High temp. grey thermoplastic - Surface mount
- Flammability rating: UL 94 V-0
- Contact: Phosphor-bronze
- Plating: Gold or tin over 1.27 μm (50 μ") nickel



ELECTRICAL PERFORMANCE

- Current rating: 3 A dc max. per individual contact
2 A dc max. per contact for fully energized connector
- Insulation resistance: 1x 10⁵ MΩ min.
- Contact resistance: 15 MΩ max. initial,
20 MΩ max. after environmental tests
- Dielectric withstanding voltage: 1000 V rms

MECHANICAL PERFORMANCE

- Mating cycles (durability): 200
- Insertion force per gold contact: 1.50 N (150 gf) max.
- Withdrawal force per gold contact: 0.30 N (30 gf) min.

OPERATING TEMPERATURE RANGE

- -65°C to +125°C

PACKAGING

- Standard: Tubes
- Optional: Tape-and-reel

PROCESSING INFORMATION

- Series 89882, 89883: compatible with wave soldering processes
- Series 71607, 71609: compatible with vapor-phase and IR reflow soldering processes

REFERENCE INFORMATION

- File no. E66906
- File no. LR46923
- Product drawing: 71607, 71609, 89882, 89883
- Product specification: HE 13/14 and IEC 603-8
- Application specification: TA-842 for SMT
- Tape and Reel packaging data : TA-856

RoHs INFORMATION

- This product is RoHs compatible according to the European Union Directive 2002/95/IEC

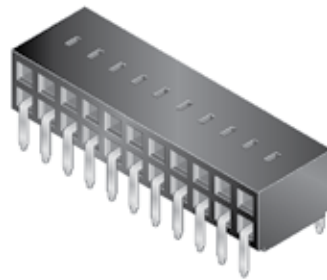

MATING DATA

- BergStik® Unshrouded vertical headers 8, 10
- BergStik® Unshrouded right angle headers 14, 16
- BergStik® continuous Unshrouded headers 12

INSERTION DEPTH

- 3,6 mm min. to 7.50 mm max.
[provides .381 mm wipe]

TYPICAL APPLICATIONS

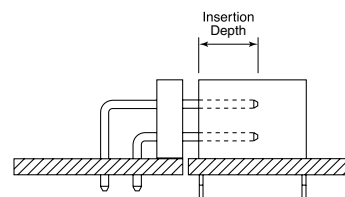
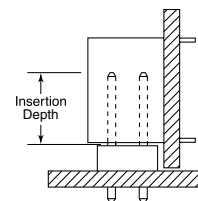

Dubox™ Horizontal Receptacles

2.54 mm (.100")

PART NUMBERS

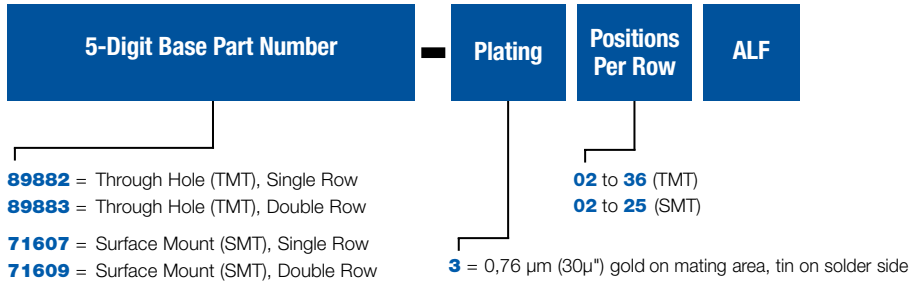

PRODUCT

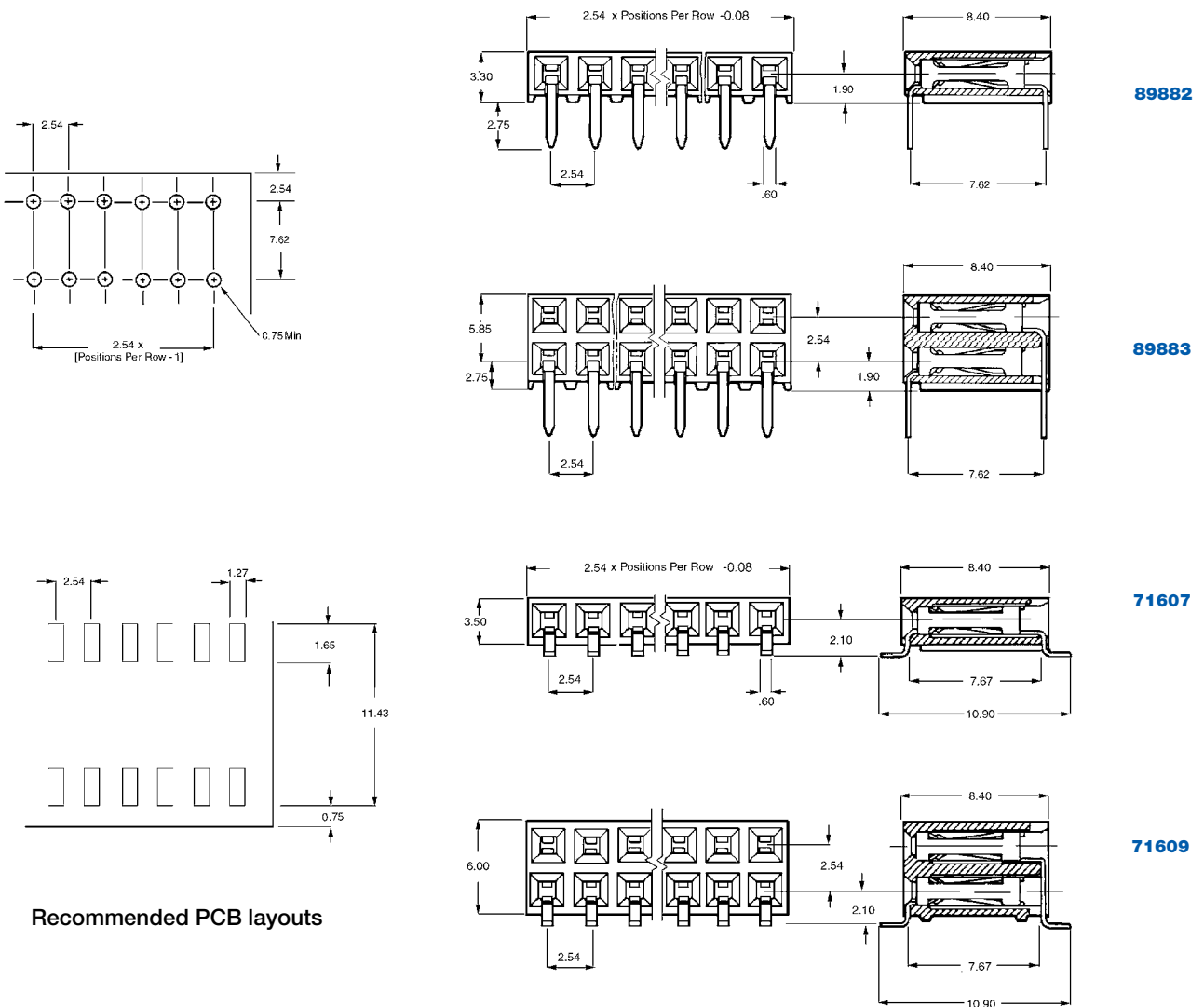

Dimension in mm

2.54 mm (.100")

FEATURES

- For use with Dubox™ crimp-to-wire housings
- Stackable end-to-end
- Passive latching, anti-reverse and anti-miss-match when used with Dubox™ crimp-to-wire housings
- Selective plating

TECHNICAL DATA

PHYSICAL

- Housing: Glass filled thermoplastic polyester
- Housing color for series 76382, 76383: blue
- Housing color for series 76384, 76385: black
- Flammability rating: UL 94 V-0
- Contact: copper Alloy
- Plating: Gold or tin over 1.27 μm (50μ") nickel

ELECTRICAL PERFORMANCE

- Current rating: 3 A continuous
- Insulation resistance: 1x 10⁵ MΩ min.
- Dielectric withstanding voltage: 1000 V rms

MECHANICAL PERFORMANCE

- Contact retention to housing: 20 N min.

OPERATING TEMPERATURE RANGE

- -40°C to +125°C



PACKAGING

- 1x2 to 1x6 and 2x2 to 2x6: plastic bags
- Other in tube

PROCESSING INFORMATION

- Compatible with wave soldering processes

REFERENCE INFORMATION

-  File no. E66906
-  File no. LR46923
- Product drawing: By 5-digit base part number
- Application specification: TA-531

RoHS INFORMATION

- This product is RoHS compatible according to the European Union Directive 2002/95/IEC

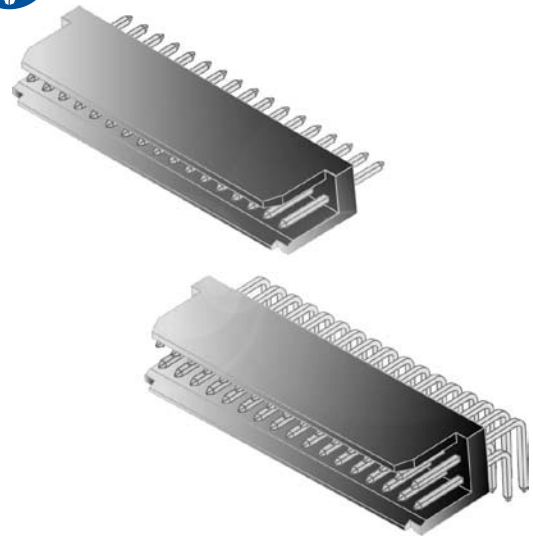

MATING DATA

- Dubox™ Crimp-to-wire contacts 32
- Dubox™ Crimp-to-wire housings 34

TYPICAL APPLICATIONS

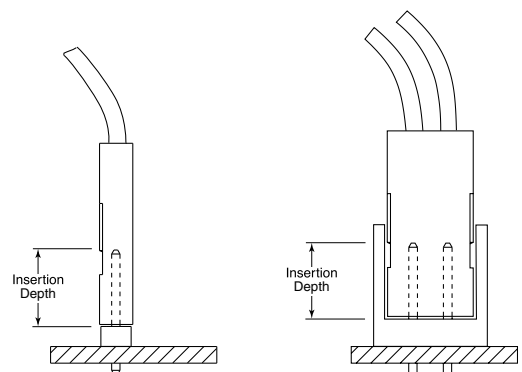
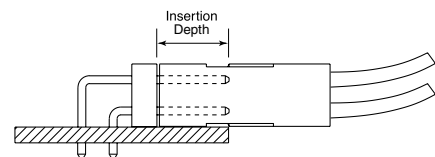

Dubox™ Shrouded Headers

2.54 mm (.100")

PART NUMBERS



- 76384** = Single row, straight
- 76382** = Single row, right angle
- 76385** = Double row, straight
- 76383** = Double row, right angle

02 up to 18

3 = 0.76 µm (30µ") gold/GXT on mating area, tin on solder side
4 = tin

76384	-	3XXLF	CORE RANGE
76385	-	3XXLF	

XX = 02, 03, 04, 05, 06, 08, 10

PRODUCT

Recommended PCB layouts

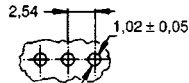

Recommended PCB layouts

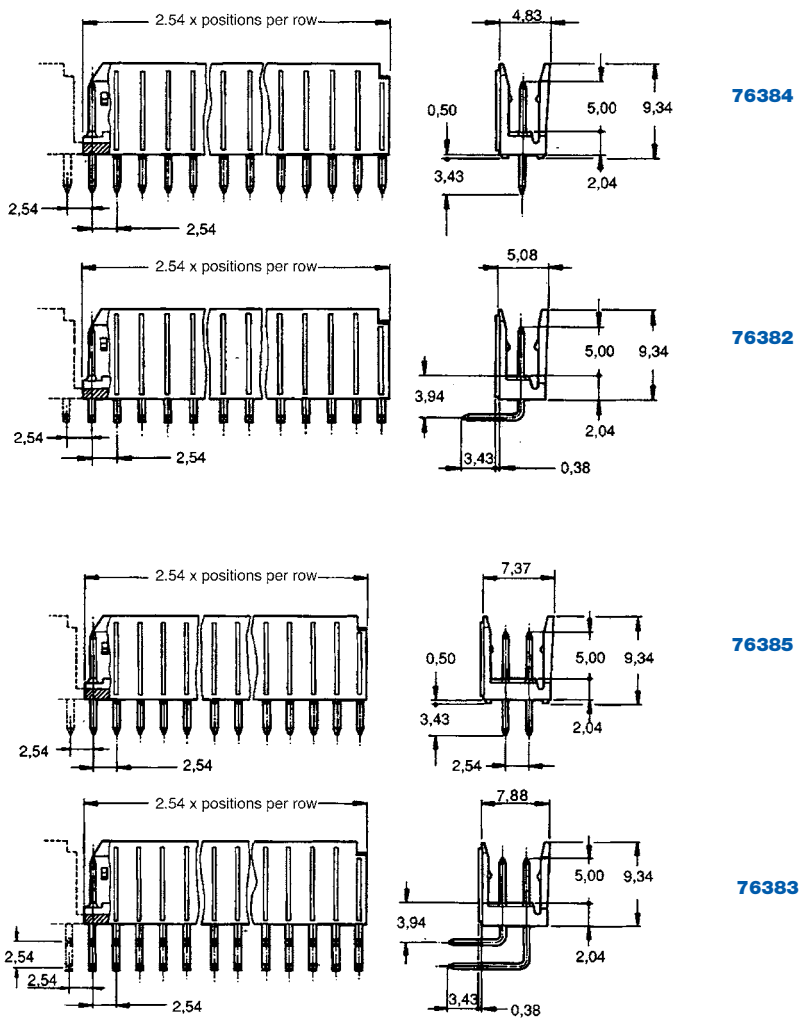
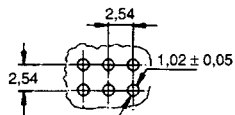

Dimension in mm

2.54 mm (.100")

FEATURES

- The Dubox™ contact has a pre-stressed, dual beam design to enable low insertion force.
- Mates with very short pins (5 mm)
- Universal crimp barrel accommodates wires from AWG 22-30
- Selective plating

TECHNICAL DATA

PHYSICAL

- Contact: phosphor bronze
- Plating: 0.76 µm (30µ") Gold over 1.27 µm (50 µ") nickel

ELECTRICAL PERFORMANCE

- Current rating: 3 A continuous
- Contact resistance after environmental test: 15Ω m max. – Contact
- Dielectric withstanding voltage: 1000 V rms

MECHANICAL PERFORMANCE

- Mating cycles (durability): 200 – Gold
- Insertion force gold finish contact: 1.3 N
- Withdrawal force (min) gold finish contact: 0.3 N.
- contact retention force to housing: 15 N per contact.



OPERATING TEMPERATURE RANGE

- -65°C to +125°C

PACKAGING

- 1 Reels
- Boxes - Loose piece

REFERENCE INFORMATION

-  File no. E66906
-  File no. LR46923
- Product drawing: By 5-digit base part number
- Product specification: BUS-12-055
- Application specification: TA-317, TA-340

RoHs INFORMATION

- This product is RoHs compatible according to the European Union Directive 2002/95/IEC



MATING DATA

- BergStik® unshrouded straight headers 8, 10
- BergStik® unshrouded right angle headers 14, 16
- Dubox™ shrouded vert./ra. headers 30
- BergStik® continuous unshrouded headers 12

INSERTION DEPTH

- Discrete Wire: 3.6 mm min. to 5.6 mm max. [provides .381 mm wipe]
- Crimp-to-Wire Housing: 5.1 mm min. to 6.2 mm max. [provides .381 mm wipe in housing]

TYPICAL APPLICATIONS

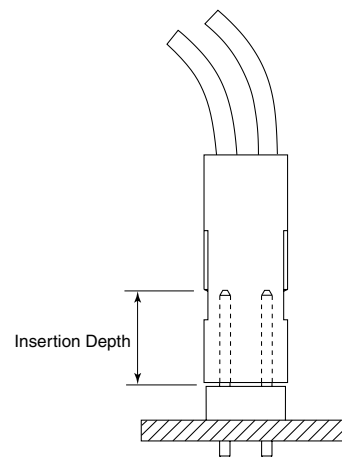

Dubox™ Crimp-to-Wire Contacts

2.54 mm (.100")

PART NUMBERS

Part numbers / Contacts on Reel

Wire size	insulation O.D.	Selective Gold Plated	Tin plated	Packaging
22-30	0.90 - 1.50	76347-301LF	76347-401LF	15.000/reel
22-30	0.90 - 1.50	76347-302 LF•	76347-402LF•	15.000/reel
22-30	0.90 - 1.50	76347-303 LF	76347-403LF	500/reel
20-22	1.10 - 1.60	76347-311LF	76347-411LF	15.000/reel
20-22	1.10 - 1.60	76347-312 LF•	76347-412LF•	15.000/reel

Part numbers / Contacts loose Piece

Wire size	insulation O.D.	Selective Gold Plated	Tin plated	Packaging
22-30	0.90 - 1.50	76357-301LF	76357-401LF	1000/box

Notes: • = reeled for application machine with left-to-right feeding



PRODUCT

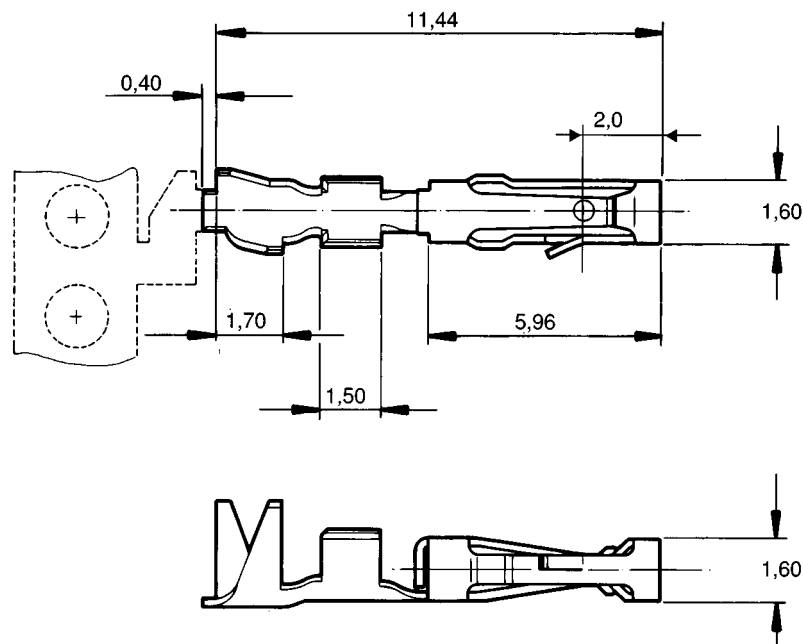

Contacts to be used with housing = 65239-xxx / 65240-xxx

Wire strip length = 3,00 ± 0,25 mm

Mating pin size = 0,62 mm square

Mating pin recommended length = 5,00 mm min.

2.54 mm (.100")

FEATURES

- For use with Dubox™ crimp-to-wire contacts
- Stackable end-to-end
- Passive latching, anti-reverse and anti-miss-match when used with Dubox™ shrouded headers
- Contacts removable for easy repairability

TECHNICAL DATA

PHYSICAL

- Housing: Glass filled thermoplastic polyester
- Housing color blue
- Flammability rating: UL 94 V-0

ELECTRICAL PERFORMANCE

- Insulation resistance: 1×10^5 M Ω min.
- Dielectric withstanding voltage: 1000 V rms

OPERATING TEMPERATURE RANGE

- -65°C to +125°C



PACKAGING

- Bulk

PROCESSING INFORMATION

- Compatible with wave soldering processes

REFERENCE INFORMATION

-  File no. E66906
-  File no. LR46923
- Product drawing: By 5-digit base part number
- Application specification: TA-317, TA-340

RoHs INFORMATION

- This product is RoHs compatible according to the European Union Directive 2002/95/IEC

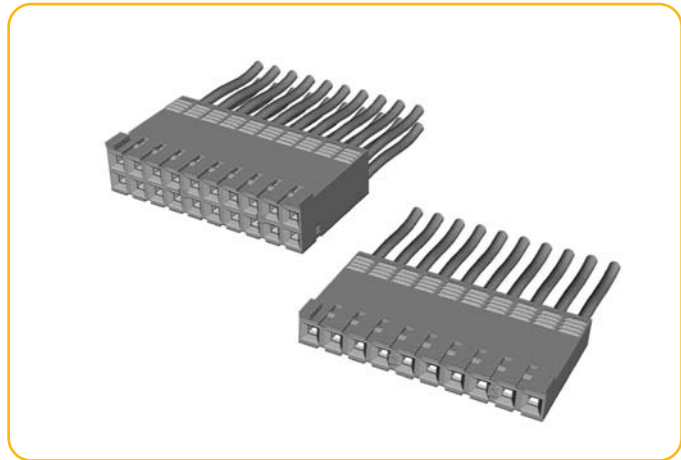

MATING DATA

- BergStik® unshrouded straight headers 8, 10
- BergStik® unshrouded right angle headers 14, 16
- Dubox™ shrouded vert./ra. headers 30

INSERTION DEPTH

- 3.6 mm min. to 6.0 mm max.

TYPICAL APPLICATIONS

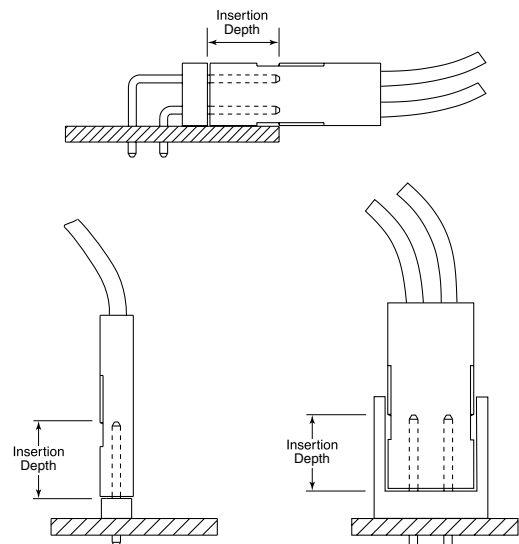

Dubox™ Crimp-to-Wire Housings

2.54 mm (.100")

PART NUMBERS

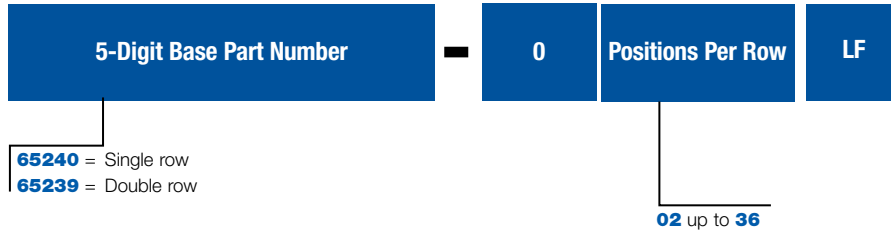

CORE RANGE

65239 - OXXLF
XX = 02, 03, 04, 05, 06, 08, 10

65240 - OXXLF
XX = 04, 06, 08, 10, 12, 16, 20

PRODUCT

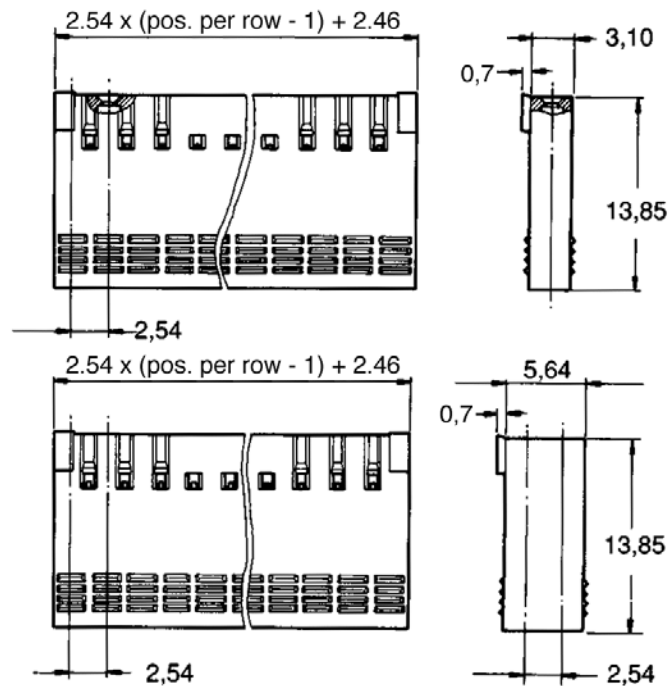

- Pin size: 0.62 mm square
- Recommended pin length: 5.00 mm min.

2.54 mm (.100")

FEATURES

- Housing uses our high reliability contact
- High temperature headers
- Passive latching system

TECHNICAL DATA

PHYSICAL

- Housing: Black thermoplastic
- Flammability rating: UL 94 V-0
- Contact: Phosphor-bronze
- Plating: Gold or tin-lead over 1.27 μm (50 μ") nickel

ELECTRICAL PERFORMANCE

- Current rating: 3 A continuous
- Insulation resistance: 1x 10⁵ MΩ min.
- Dielectric withstanding voltage: 1000 V rms

MECHANICAL PERFORMANCE

- Contact retention to housing: 17.76 N min.

OPERATING TEMPERATURE RANGE

- -40°C to +125°C



PACKAGING

- Bags

PROCESSING INFORMATION

- Compatible with wave soldering processes

REFERENCE INFORMATION

-  File no. E66906
-  File no. LR46923
- Product drawing: By 5-digit base part number
- Product specification: BUS-12-067, BUS-12-075
- Application specification: TA-531

RoHs INFORMATION

- This product is RoHs compatible according to the European Union Directive 2002/95/IEC

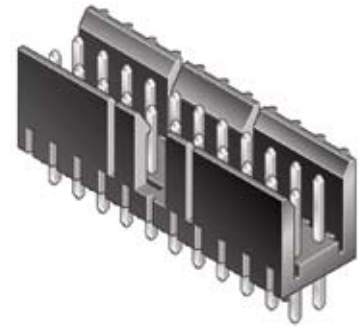

MATING DATA

- PV™ Crimp-to-wire contacts 38
- PV™ Crimp-to-wire housings 40

TYPICAL APPLICATIONS

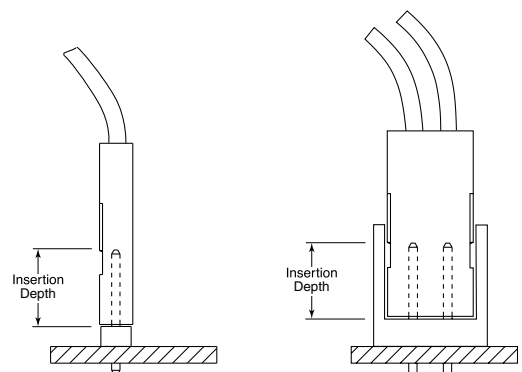
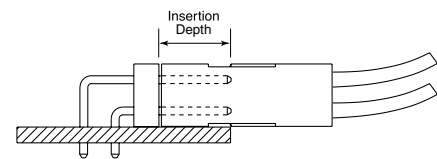

PV™ Shrouded Headers

2.54 mm (.100")

PART NUMBERS

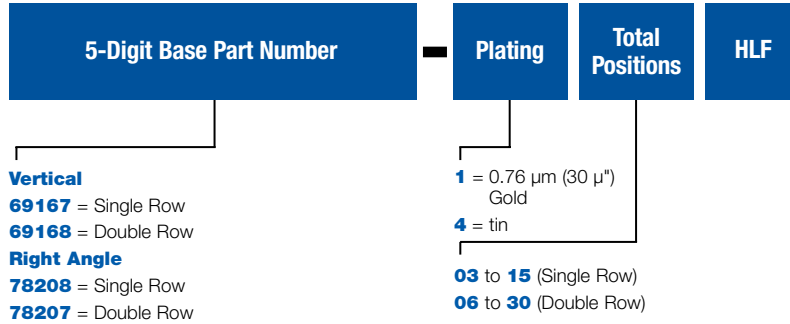

PRODUCT

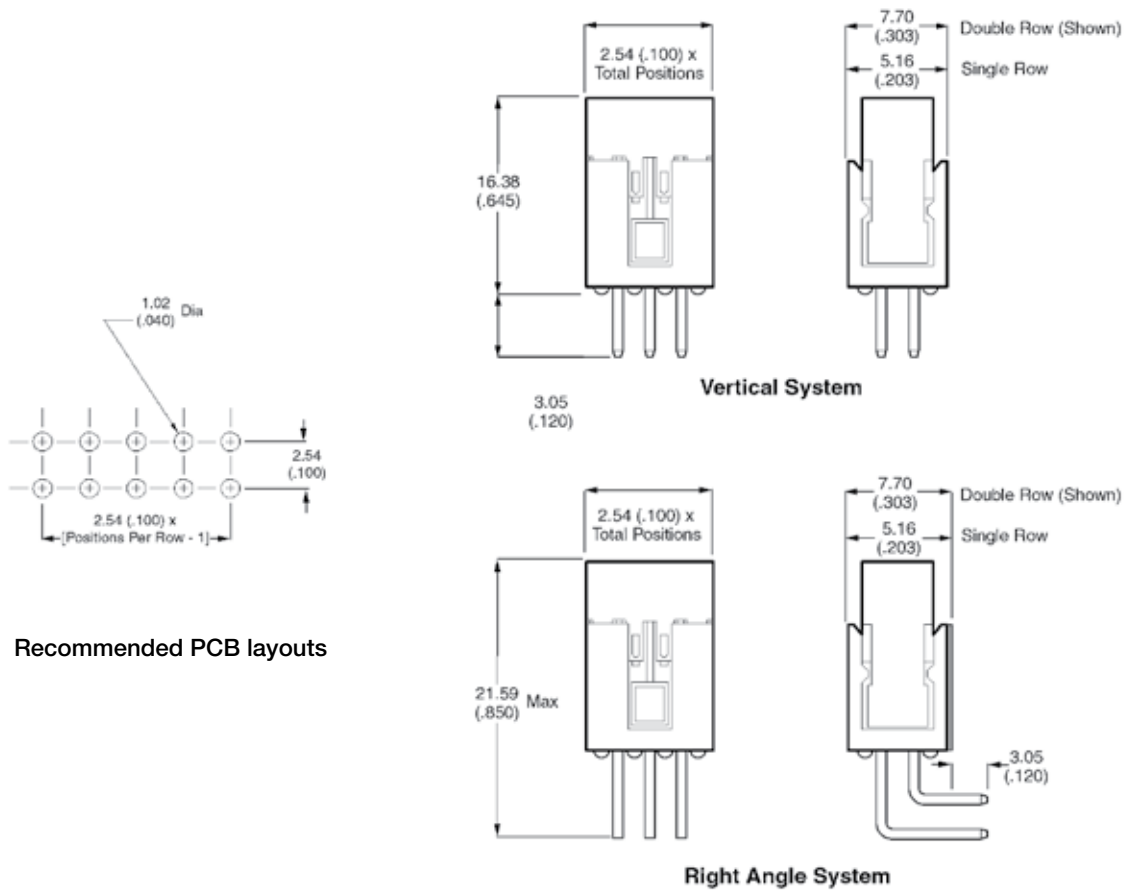

Dimension in mm

2.54 mm (.100")

FEATURES

- High reliability contacts for shock and vibration applications
- Three spring thickness options meet application specific insertion, withdrawal, and normal force requirements
- Leaf spring design provides constant retention force after repeated cycles

TECHNICAL DATA

PHYSICAL

- Contact: Brass body with beryllium-copper spring
- Pin: Brass
- Plating: Gold or tin over 1.27 µm (50 µ") nickel

ELECTRICAL PERFORMANCE

- Current rating: 3 A continuous depending on wire size
- Insulation resistance: 5000 mΩ min.
- Contact resistance after environmental test: 15Ω m max. – Contact
- Dielectric withstanding voltage: 1000 V rms

MECHANICAL PERFORMANCE

- Mating cycles (durability): 1000 - Gold
- Insertion force per gold contact:
 - 2.35 N (240 gf) - Standard spring
 - 4.41 N (450 gf) - High spring
 - 10.79 N (1100 gf) - Ultra high spring

OPERATING TEMPERATURE RANGE

- 65°C to +125°C

PACKAGING

- 1 Reels
- Boxes - Loose piece

REFERENCE INFORMATION

- File no. E66906
- File no. LR46923
- Product drawing: By 5-digit base part number
- Product specification: BUS-12-067 Contact
- Application specification: TA-75, TA-146 - Contact, TA-295, TA-228 and TA-302

RoHS INFORMATION

- This product is RoHS compatible according to the European Union Directive 2002/95/IEC

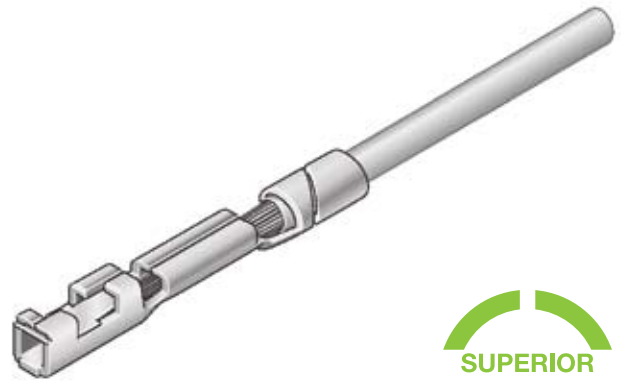

MATING DATA

- Continuous unshrouded headers 12
- Unshrouded vertical headers 8, 10
- Unshrouded right angle headers 14, 16

INSERTION DEPTH

- Discrete Wire: 3.5 mm min. to 5.3 mm max. [provides .381 mm wipe]
- Crimp-to-Wire Housing: 4.2 mm min. to 5.3 mm max. [provides .381 mm (.015") wipe in housing]

TYPICAL APPLICATIONS

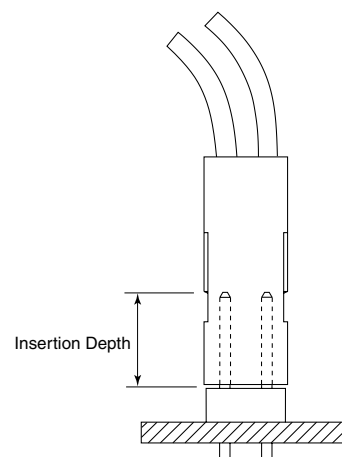

PV™ Crimp-to-Wire Contacts

2.54 mm (.100")

PART NUMBERS



HOW TO SELECT THE RIGHT CONTACT

- Step 1** Select Application
- Step 2** Select Spring Force
- Step 3** Select Wire Size

Application	Spring Force
Housing	
40-72 Contacts Per Housing	Standard
10-50 Contacts Per Housing	High
2-20 Contacts Per Housing	Ultra High
Discrete Contact	Ultra High

Wire Size (AWG)	Application Spring Force	Part Number
18, 20 or two 22 or two 24	Standard	48276-002LF
	High	48047-002LF
	Ultra High	47566-002LF
22, 24, 26 or two 26 or two 28	Standard	47457-002LF
	High	47439-002LF
	Ultra High	47565-002LF
28, 30, 32 or two 30 or two 32	Standard	48048-002LF
	High	47437-002LF
	Ultra High	47564-002LF

PRODUCT

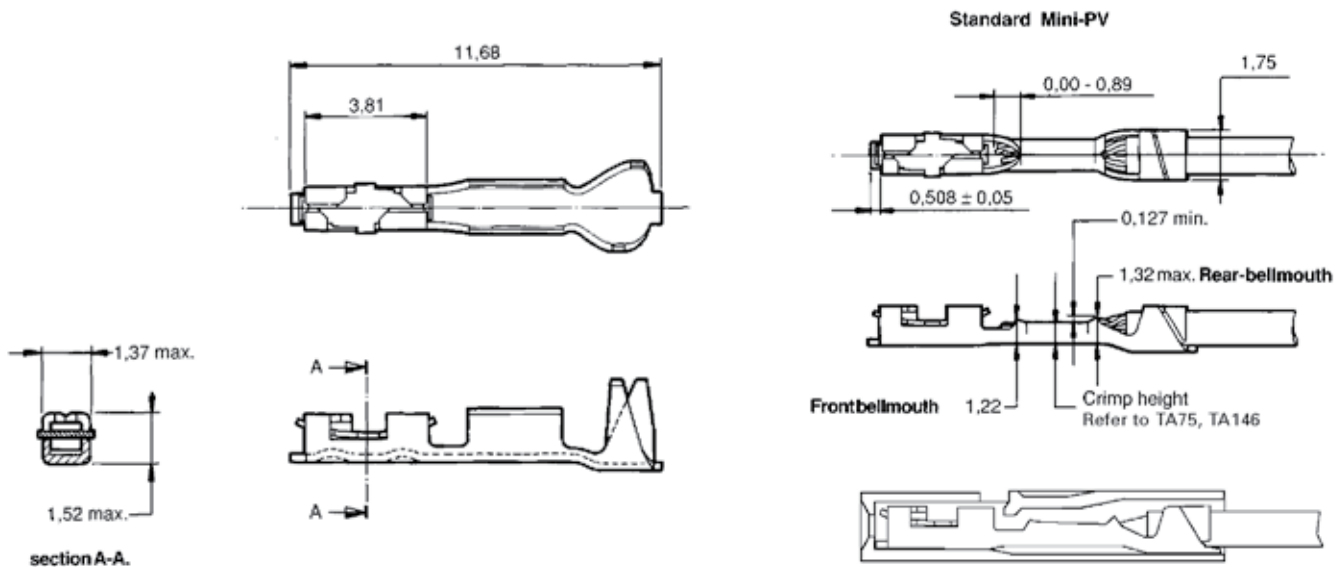

2.54 mm (.100")

FEATURES

- Lowest profile housing in the industry
- Designed for use with our high reliability PV™ Contact

TECHNICAL DATA

PHYSICAL

- Housing: Black thermoplastic
- Flammability rating: UL 94 V-0

ELECTRICAL PERFORMANCE

- Insulation resistance: 1×10^5 M Ω min.
- Dielectric withstanding voltage: 1000 V rms

MECHANICAL PERFORMANCE

- Contact retention to housing: 17.76 N min.

OPERATING TEMPERATURE RANGE

- 40°C to +125°C

PACKAGING

- Bags

PROCESSING INFORMATION

- Compatible with wave soldering processes

REFERENCE INFORMATION

- File no. E66906
- File no. LR46923
- Product drawing: By 5-digit base part number
- Product specification: BUS-12-067
- Application specification: TA-531

RoHS INFORMATION

- This product is RoHS compatible according to the European Union Directive 2002/95/IEC

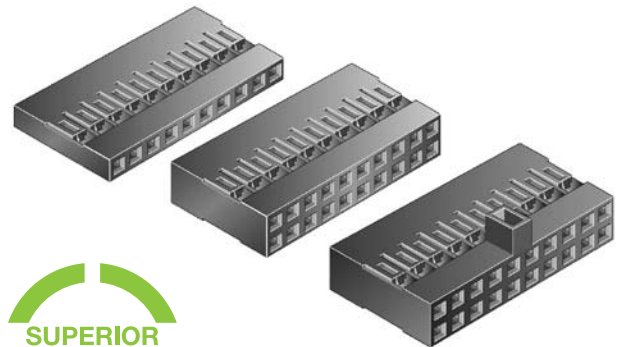

MATING DATA

- Continuous unshrouded headers 12
- Unshrouded vertical headers 8, 10
- Unshrouded right angle headers 14, 16

INSERTION DEPTH

- 4.2 mm (.165") min. to 5.3 mm (.210") max.
[provides .381 mm (.015") wipe in housing].

TYPICAL APPLICATIONS

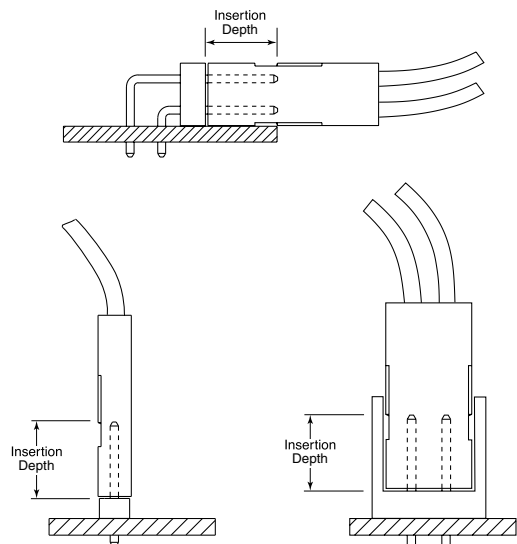

PV™ Crimp-to-Wire Housings

2.54 mm (.100")

PART NUMBERS



- 65039** = Single Row
- 65043** = Double Row
- 65846** = Double Row with Center Key

Total Positions	Single Row		Double Row		
	65039	78211	Total Positions	65043	65846
			4	-035	
2	-035		6	-034	
3	-034	-003	8	-033	
4	-033	-004	10	-032	
5	-032	-005	12	-031	-017
6	-031	-006	14	-030	
7	-030	-007	16	-029	
8	-029	-008	18	-028	
9	-028	-009	20	-027	
10	-027	-010	22	-026	-018
11	-026	-011	24	-025	
12	-025	-012	26	-024	-019
13	-024	-013	28	-023	-020
14	-023	-014	30	-022	
15	-022	-015	32	-021	-021
16	-021		34	-020	-022
17	-020		36	-019	-023
18	-019		38	-018	

Total Positions	Single Row		Double Row		
	65039	78211	Total Positions	65043	65846
19	-018		40	-017	-024
20	-017		42	-016	-025
21	-016		44	-015	-004
22	-015		46	-014	-026
23	-014		48	-013	-027
24	-013		50	-012	
25	-012		52	-011	-028
26	-011		54	-010	
27	-010		56	-009	-029
28	-009		58	-008	-030
29	-008		60	-007	-013
30	-007		62	-006	-031
31	-006		64	-005	-009
32	-005		66	-004	-032
33	-004		68	-003	-033
34	-003		70	-002	-034
35	-002		72	-001	-035
36	-001				

PRODUCT

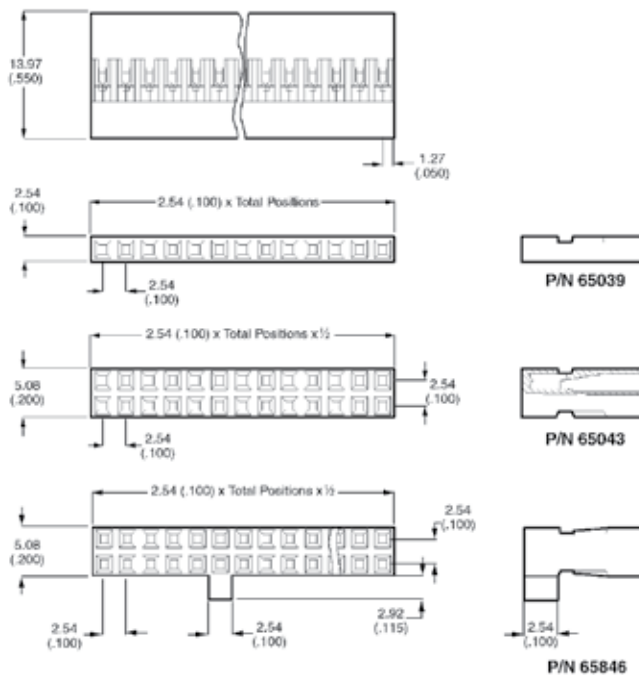

2.54 mm (.100")

FEATURES

- Recessed pins assure proper alignment and eliminate damage during mating
- End windows for latching with IDC receptacle

TECHNICAL DATA

PHYSICAL

- Housing: Glass filled, thermoplastic polyester, blue
- Flammability rating: UL 94 V-0
- Pin: Phosphor-bronze
- Plating: Gold/GXT over 1.27 µm (50µ") nickel

ELECTRICAL PERFORMANCE

- Current rating: 3 A continuous
- Insulation resistance: 1x 10⁵ MΩ min.
- Dielectric withstanding voltage: 500 V rms min.

MECHANICAL PERFORMANCE

- Pin retention to housing: 20 N min.

OPERATING TEMPERATURE RANGE

- -65°C to +105°C



PACKAGING

- Tubes

PROCESSING INFORMATION

- Compatible with wave soldering processes

REFERENCE INFORMATION

-  File no. E66906
-  File no. LR46923
- Product drawing: By 5-digit base part number
- Product specification: BUS-12-082

RoHS INFORMATION

- This product is RoHS compatible according to the European Union Directive 2002/95/IEC

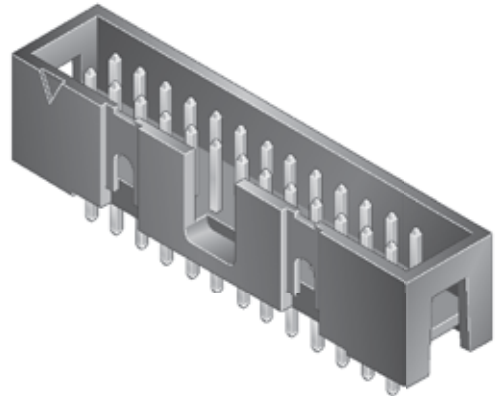

MATING DATA

- Quickie™ IDC receptacles 48

TYPICAL APPLICATIONS

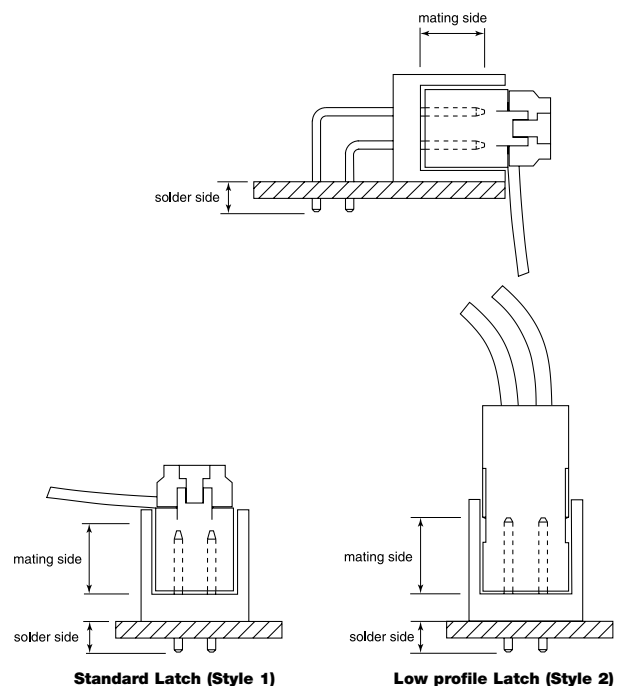

Quickie™ Shrouded Headers, Low Profile

2.54 mm (.100")

PART NUMBERS

5-Digit Base Part Number	Plating	Total Positions	LF
<p>Through mount 75869 = Vertical 75867 = Right angle</p>		<p>30 = 4 pos. 31 = 6 pos. 32 = 8 pos. 01 = 10 pos. 02 = 14 pos. 03 = 16 pos. 04 = 20 pos. 05 = 26 pos. 06 = 34 pos. 07 = 40 pos. 08 = 50 pos. 09 = 60 pos. 10 = 64 pos.</p>	
<p>1 = 0.76 μm (30μ")gold/GXT on mating area, tin on solder side</p>			

PRODUCT

Vertical

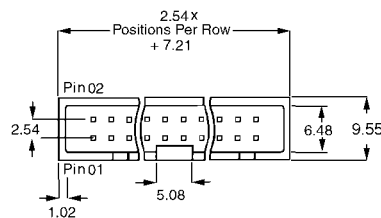

Right Angle

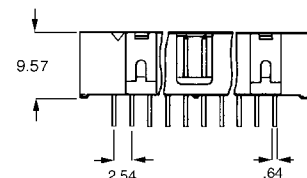
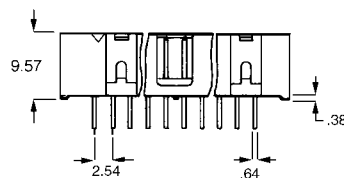
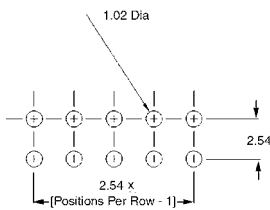
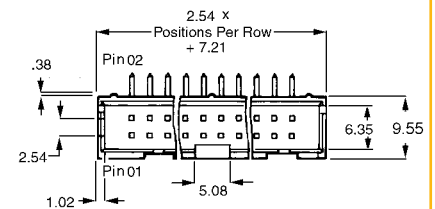

Recommended PCB layouts

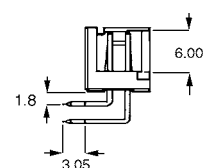
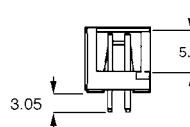

Dimension in mm

2.54 mm (.100")

FEATURES

- High temperature housing
- Compatible with IR reflow soldering processes
- Tape-and-Reel packaging for automatic pick-and-place

TECHNICAL DATA

PHYSICAL

- Housing: Glass filled, high temperature thermoplastic polyester, black
- Flammability rating: UL 94 V-0
- Pin: Phosphor-bronze
- Plating: Gold/GXT over 1.27 μm (50μ") nickel



ELECTRICAL PERFORMANCE

- Current rating: 3 A continuous
- Insulation resistance: 1 x 10⁵ MΩ min.
- Dielectric withstanding voltage: 500 V rms min.

MECHANICAL PERFORMANCE

- Pin retention to housing: 20 N min.

OPERATING TEMPERATURE RANGE

- 65°C to +125°C

PACKAGING

- SMT: Tape-and-reel with pick-up cap
- PiP, right angle: Tube without pick-up cap
- PiP, straight: Tape and reel

PROCESSING INFORMATION

- Compatible with wave, vapor-phase, and IR reflow soldering processes

REFERENCE INFORMATION

- File no. E66906
- File no. LR46923
- Product drawing: By 5-digit base part number
- Product specification: BUS-12-055

RoHS INFORMATION

- This product is RoHS compatible according to the European Union Directive 2002/95/IEC

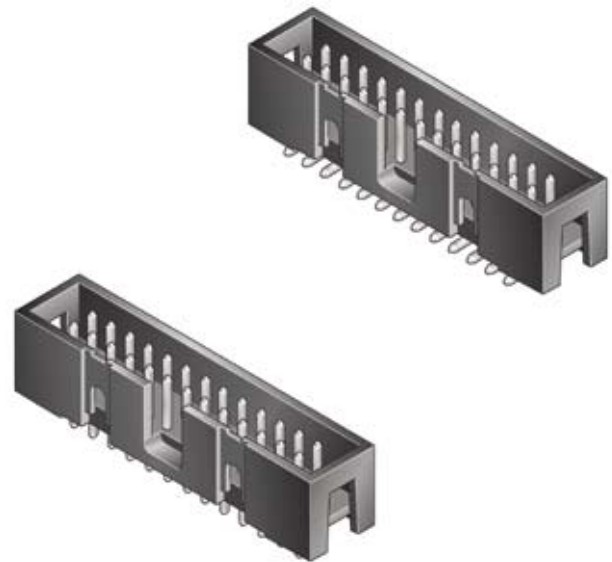

MATING DATA

- Quickie™ IDC receptacles 48

TYPICAL APPLICATIONS

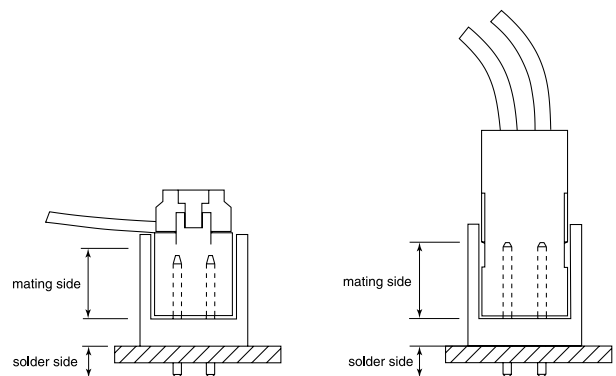

Quickie™ Shrouded Headers, Low Profile, SMT, Pin-in-Paste

2.54 mm (.100")

PART NUMBERS

SMT (Surface Mount)

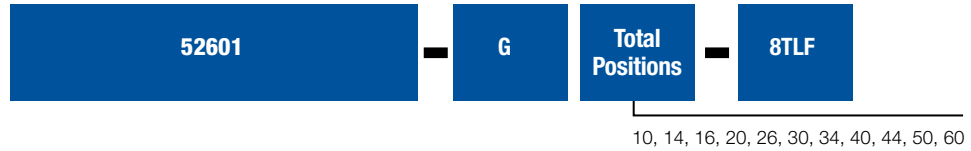

PIP (Pin-in-Paste)



PRODUCT

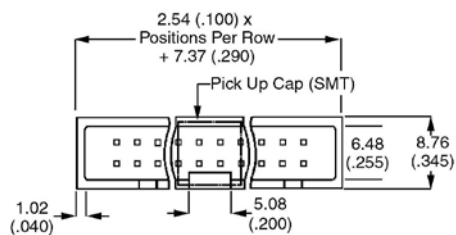

52601

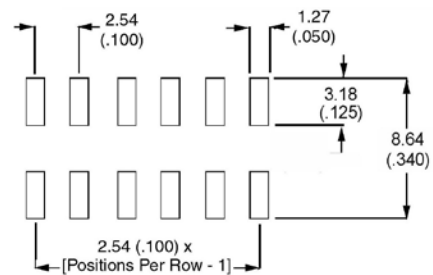

Recommended PCB layouts

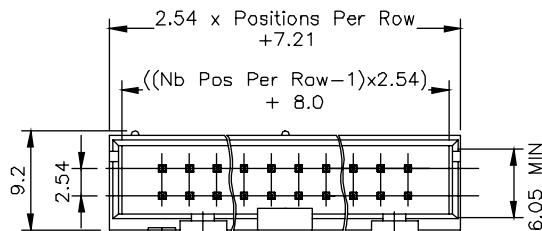
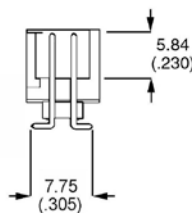
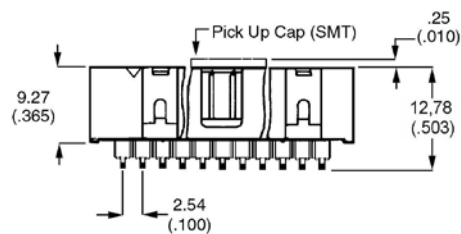

10056844

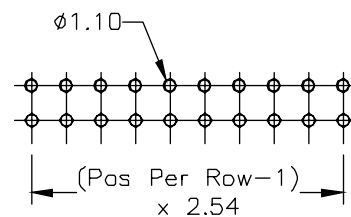

Recommended PCB layouts

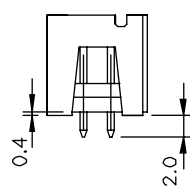
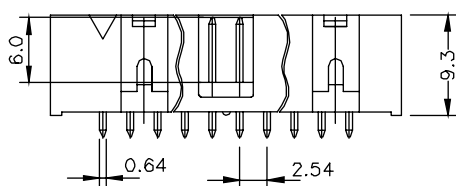

Dimension in mm

2.54 mm (.100")

FEATURES

- ▶ Selective plating
- ▶ Recessed pins assure proper alignment and eliminate damage during mating

TECHNICAL DATA

PHYSICAL

- ▶ Housing: Glass filled, high temperature thermoplastic polyester, grey
- ▶ Flammability rating: UL 94 V-0
- ▶ Pin: Phosphor-bronze
- ▶ Plating: Gold/GXT over 1.27 μm (50μ") nickel



ELECTRICAL PERFORMANCE

- ▶ Current rating: 3 A continuous
- ▶ Insulation resistance: 1x 10⁵ MΩ min.
- ▶ Dielectric withstanding voltage: 500 V rms min.

MECHANICAL PERFORMANCE

- ▶ Pin retention to housing: 20 N min.

OPERATING TEMPERATURE RANGE

- ▶ -65°C to +105°C

PACKAGING

- ▶ Tubes

PROCESSING INFORMATION

- ▶ Compatible with wave soldering processes

REFERENCE INFORMATION

- ▶ File no. E66906
- ▶ File no. LR46923
- ▶ Product drawing: By 5-digit base part number
- ▶ Product specification: BUS-12-082

RoHS INFORMATION

- ▶ This product is RoHS compatible according to the European Union Directive 2002/95/IEC

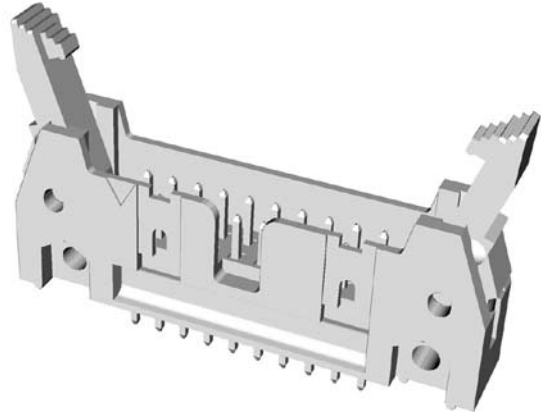

MATING DATA

- ▶ Quickie™ IDC receptacles 48

TYPICAL APPLICATIONS

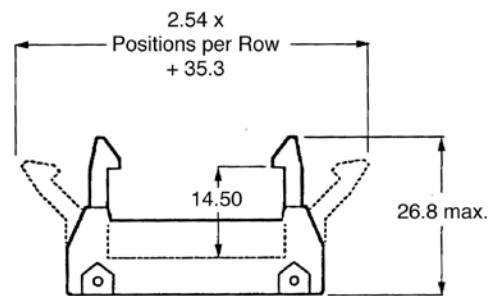

Standard Latch (Style 1)

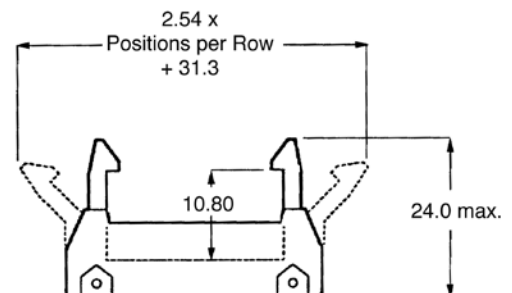

Low profile Latch (Style 2)

Quickie™ Shrouded Headers, Eject Latch

2.54 mm (.100")

PART NUMBERS

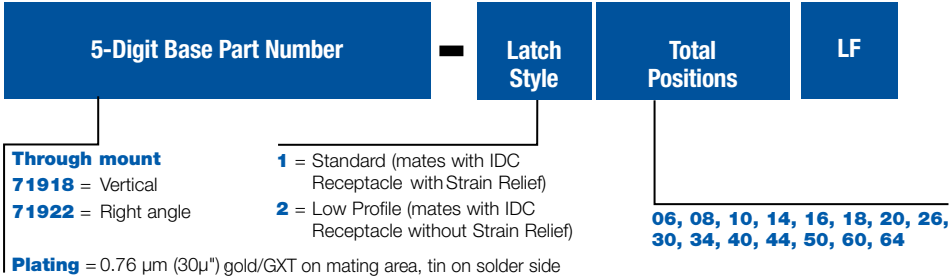

71918	-	1XXLF	CORE RANGE
71922	-	1XXLF	

XX = 06, 08, 10, 16, 20

PRODUCT

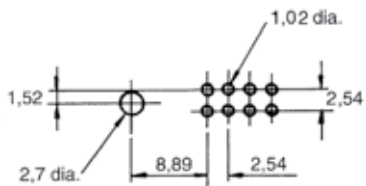

Vertical

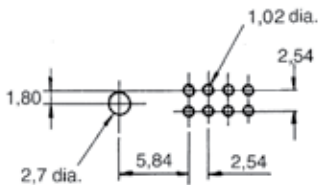
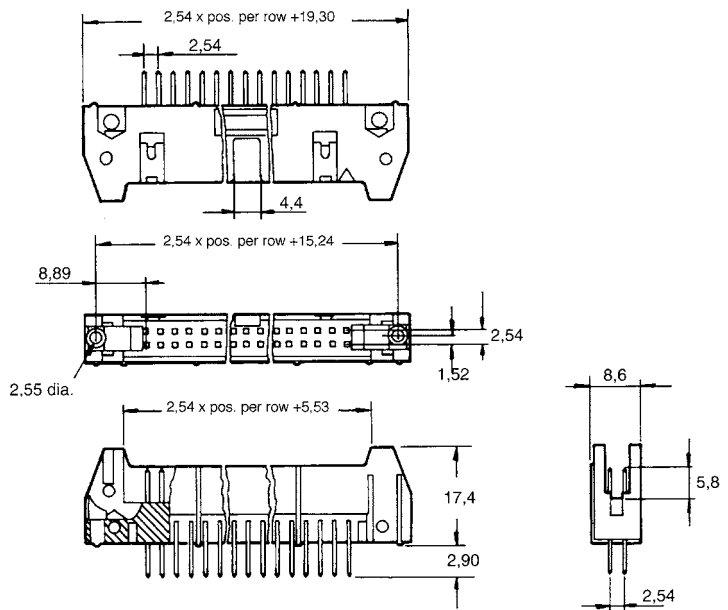

Right Angle

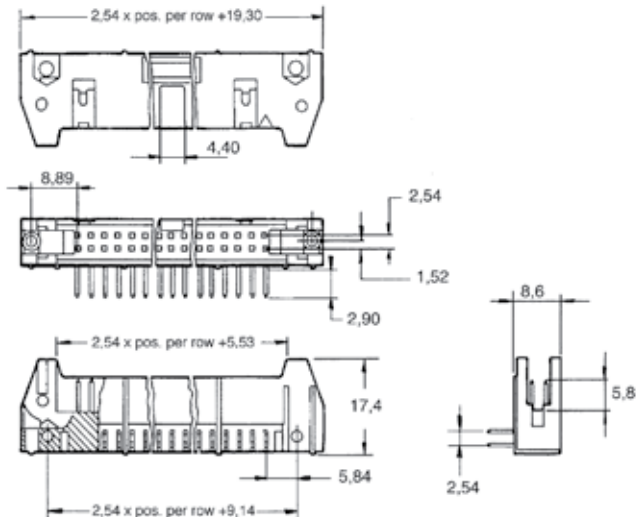

Recommended PCB layouts

Dimension in mm

2.54 mm (.100")

TECHNICAL DATA

PHYSICAL

- Housing: Grey thermoplastic
Flammability rating: UL 94 V-0
- Contact: Phosphor-bronze
- Plating: 0.76 µm (30µ") Gold over 1.27 µm (50 µ") nickel

ELECTRICAL PERFORMANCE

- Current rating: 1 A continuous
- Insulation resistance: 1x 10⁵ MΩ min.
- Contact resistance: 15 mΩ max.
- Dielectric withstanding voltage: 1000 V min. rms (sea level)

MECHANICAL PERFORMANCE

- Mating cycles (durability): 100

OPERATING TEMPERATURE RANGE

- -65°C to +105°C



PACKAGING

- Tubes

PROCESSING INFORMATION

- Compatible with wave soldering processes

REFERENCE INFORMATION

-  File no. E66906
-  File no. LR46923
- Product drawing: By 5-digit base part number
- Product specification: BUS-12-095

RoHS INFORMATION

- This product is RoHS compatible according to the European Union Directive 2002/95/IEC

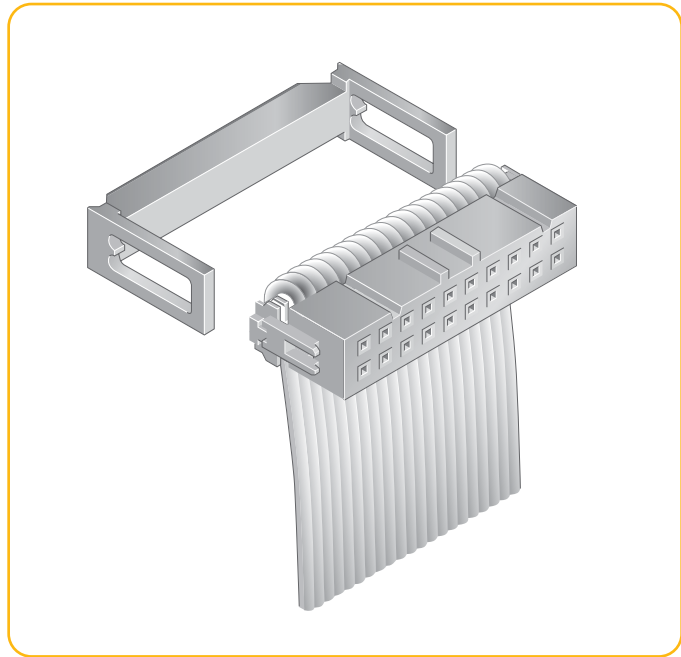

MATING DATA

- BergStik® unshrouded vertical headers 8, 10, 12
- Quickie® shrouded low profile headers 42, 44
- Quickie® shrouded eject latch headers 46

TYPICAL APPLICATIONS

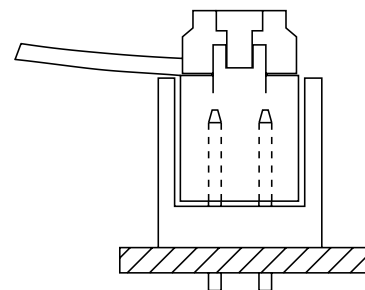

Low profile Latch (Style 2)

Quickie™ IDC Receptacle

2.54 mm (.100")

PART NUMBERS

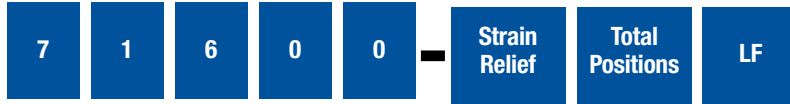

Note: 4 position available without strain relief only

04, 06, 08, 10, 14, 16, 20, 26, 34, 40, 50, 60, 64

- 0 = Standard (Mates with Shrouded Eject Latch Header Latch 1)
- 1 = None (Mates with Shrouded Eject Latch Header Latch 2)
- 6 = Latching (Mates with Low Profile Headers)

71600 - 0XXLF **CORE RANGE**
 XX = 04, 06, 08, 10, 16, 20

PRODUCT

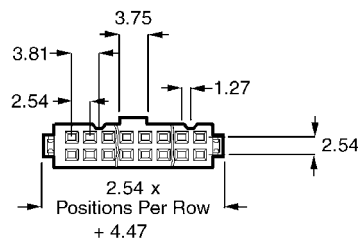
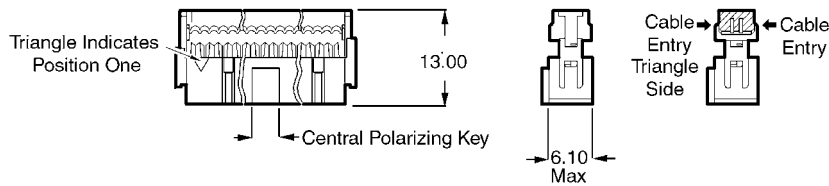

0 Standard Strain Relief

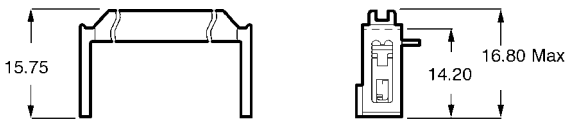

6 Latching Strain Relief For Low Profile Header

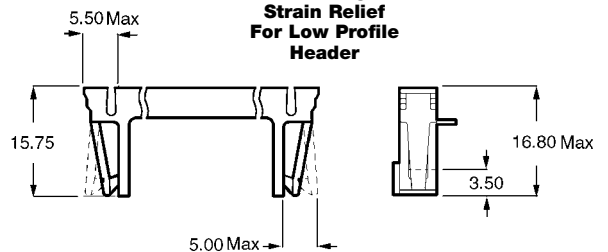

1 Without Strain Relief

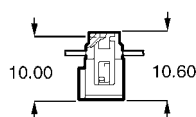

Dimension in mm

2.54 mm (.100")

FEATURES

- Ideal for daisy chain applications
- Single piece design provides one of the lowest applied costs in the industry

TECHNICAL DATA

PHYSICAL

- Housing: Blue thermoplastic
- Flammability rating: UL 94 V-0
- Pin: Phosphor-bronze
- Plating: Tin over 1.27 μm (50μ") nickel

ELECTRICAL PERFORMANCE

- Current rating: 1 A continuous
- Insulation resistance: 1x 10⁵ MΩ min.
- Contact resistance: 15 mΩ max.
- Dielectric withstanding voltage: 1000 V min. rms (sea level)

OPERATING TEMPERATURE RANGE

- -65°C to +125°C



PACKAGING

- Tubes

PROCESSING INFORMATION

- Compatible with wave and vapor phase soldering processes — Low temperature

REFERENCE INFORMATION

-  File no. E66906
-  File no. LR46923
- Product drawing: By 5-digit base part number
- Product specification: BUS-12-095

RoHS INFORMATION

- This product is RoHS compatible according to the European Union Directive 2002/95/IEC

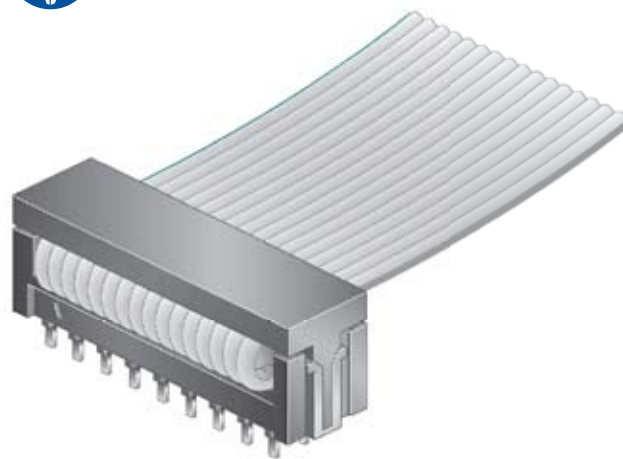

TYPICAL APPLICATIONS

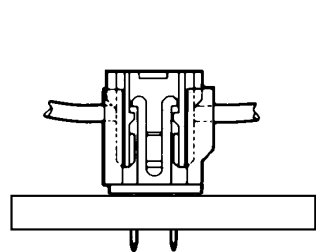

Quickie™ IDC PCB Connector

2.54 mm (.100")

PART NUMBERS



- | | | |
|---------------------|---------------------|---------------------|
| 06 = 6 pos. | 18 = 18 pos. | 34 = 34 pos. |
| 08 = 8 pos. | 20 = 20 pos. | 40 = 40 pos. |
| 10 = 10 pos. | 24 = 24 pos. | 50 = 50 pos. |
| 14 = 14 pos. | 26 = 26 pos. | 60 = 60 pos. |
| 16 = 16 pos. | 30 = 30 pos. | 64 = 64 pos. |

PRODUCT

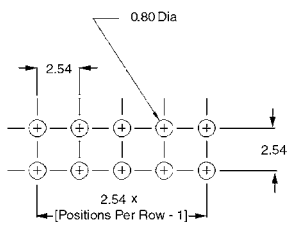

Recommended PCB layouts

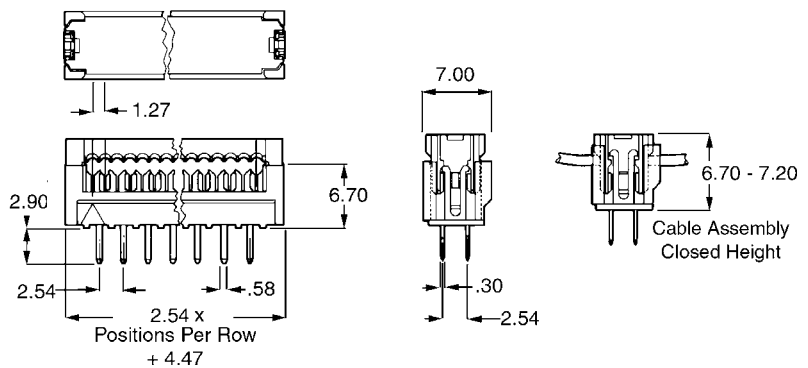

Dimension in mm

TECHNICAL DATA

PHYSICAL

- Housing: High-temperature, black thermoplastic
- Flammability rating: UL 94 V-0
- Pin: Phosphor-bronze
- Plating: Gold/GXT over 1.27 μm (50μ") nickel



ELECTRICAL PERFORMANCE

- Current rating: 3 A continuous
- Insulation resistance: 1 x 10⁵ MΩ min.
- Contact resistance: 25 mΩ max.
- Dielectric withstanding voltage: 650 V
- Voltage rating: 200 V.

MECHANICAL PERFORMANCE

- Mating cycles (durability): 100.

OPERATING TEMPERATURE RANGE

- -55°C to +125°C

PACKAGING

- Standard: TMT in tubes (04 to 06 pos. packed in box)
- SMT in Tape-and-reel
- Optional: SMT in Tubes

PROCESSING INFORMATION

- Compatible with wave, vapor-phase, and IR reflow soldering processes

REFERENCE INFORMATION

- File no. E66906
- File no. LR46923
- Product drawing: 57102 or 57202
- Product specification: DPS-12-011 and GS-12-163
- Tape and Reel packaging data: TA-884

RoHs INFORMATION

- This product is RoHs compatible according to the European Union Directive 2002/95/IEC

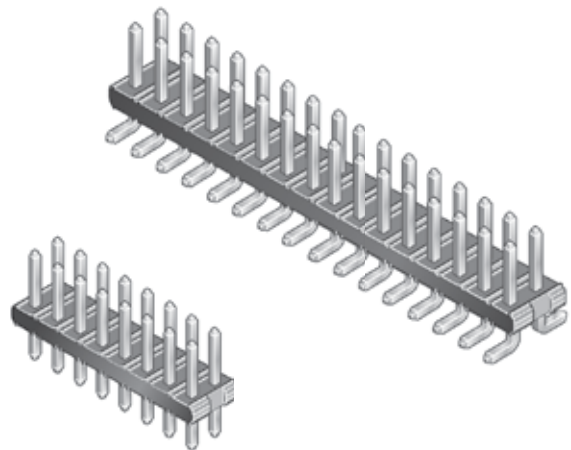

MATING DATA

■ Minitek™ ctw contacts and housings	72
■ Minitek™ Vertical receptacles	60
■ Minitek™ Shunts	62
■ Minitek™ IDC receptacles	76

TYPICAL APPLICATIONS

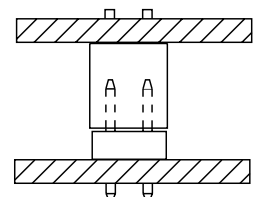
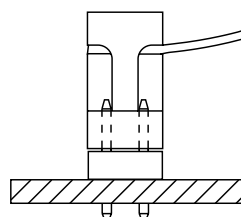
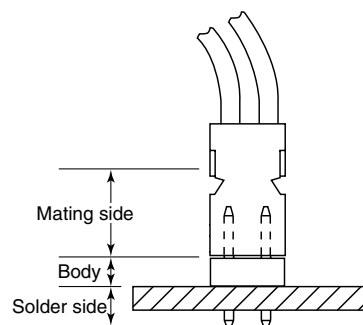

2.00 mm (.079")

Minitek™ Unshrouded Vertical Headers

PART NUMBERS



1 = Through Mount (TMT)
2 = Surface Mount (SMT)

G = 0,76 μm (30μ") gold/GXT on mating area,
 2-6 μm (79-237μ") Tin on solder side
F = Gold flash on mating area,
 2-6 μm (79-237μ") Tin on solder side

02 to 25 (TMT)
02 to 25 (SMT)

U = Tube without cap (TMT)
A = Tape-and-reel with cap (SMT)

57202 - G 52 - XXALF **CORE RANGE**
 XX = 02, 03, 04, 05, 06, 08, 10

Surface Mount		Through Mount			
Pin Style	Mating side mm	Pin Style	Mating Side mm	Solder Side mm	OAL mm
51	2.00	06	4.00	2.50	8.00
52	4.00	08	4.00	3.00	8.50

2.00 mm (.079")

PRODUCT

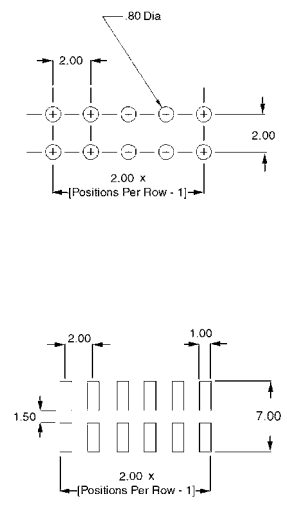

Recommended PCB layouts

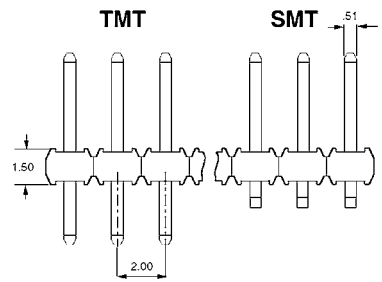
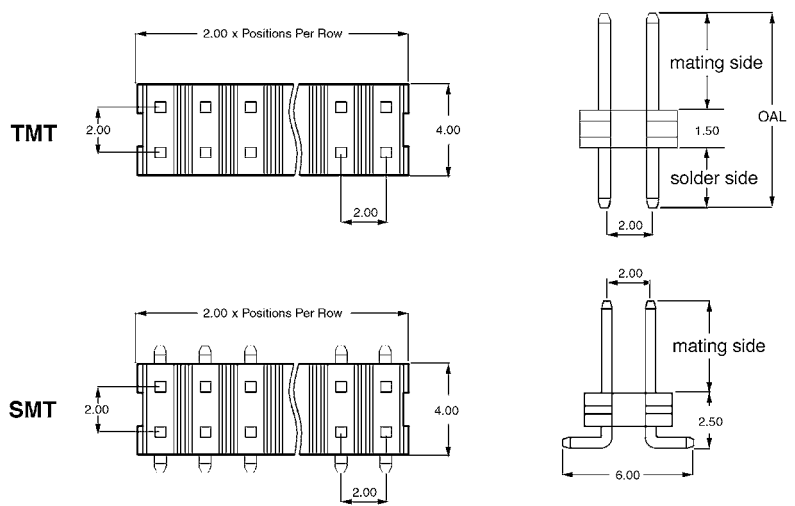

Dimension in mm

FEATURES

- High temperature plastic
- Selective plating

TECHNICAL DATA

PHYSICAL

- Housing: High-temperature, black thermoplastic
- Flammability rating: UL 94 V-0
- Pin: Phosphor-bronze
- Plating: Gold/GXT over 1.27 μm (50μ") nickel



ELECTRICAL PERFORMANCE

- Current rating: 3 A continuous
- Insulation resistance: 1x 10⁵ MΩ min.
- Contact resistance: 25 mΩ max.
- Dielectric withstanding voltage: 650 V
- Voltage rating: 200 V.

MECHANICAL PERFORMANCE

- Mating cycles (durability): 100.

OPERATING TEMPERATURE RANGE

- 55°C to +125°C

PACKAGING

- Tubes (04 to 06 pos. packed in box)

PROCESSING INFORMATION

- Compatible with wave, vapor-phase, and IR reflow soldering processes

REFERENCE INFORMATION

- File no. E66906
- File no. LR46923
- Product drawing: 98423
- Product specification: DPS-12-011 and GS-12-163

RoHS INFORMATION

- This product is RoHS compatible according to the European Union Directive 2002/95/IEC

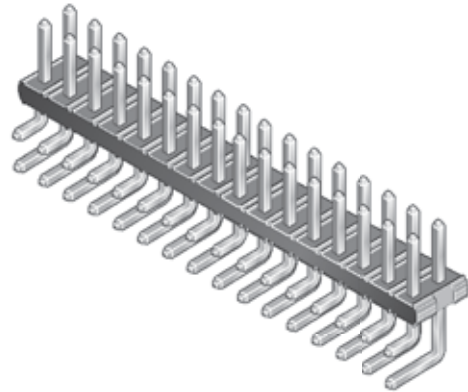

MATING DATA

■ Minitek™ ctw contacts and housings	72
■ Minitek™ Vertical receptacles	60
■ Minitek™ Shunts	62
■ Minitek™ IDC receptacles	76

TYPICAL APPLICATIONS

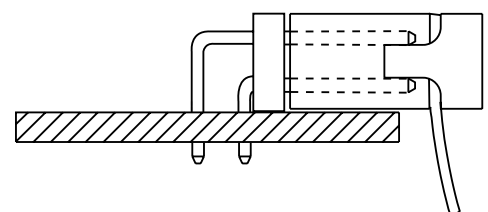
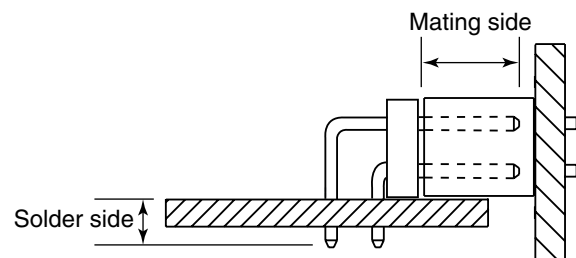

Minitek™ Unshrouded Right Angle Headers

PART NUMBERS



G = 0,76 μm ($30\mu\text{m}$) gold/GXT on mating area,
2-6 μm ($79\text{-}237\mu\text{m}$) Tin on solder side
F = Gold flash on mating area,
2-6 μm ($79\text{-}237\mu\text{m}$) Tin on solder side

02 to 25

2.00 mm (.079")

PRODUCT

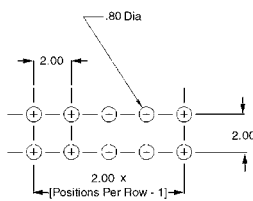

Recommended PCB layouts

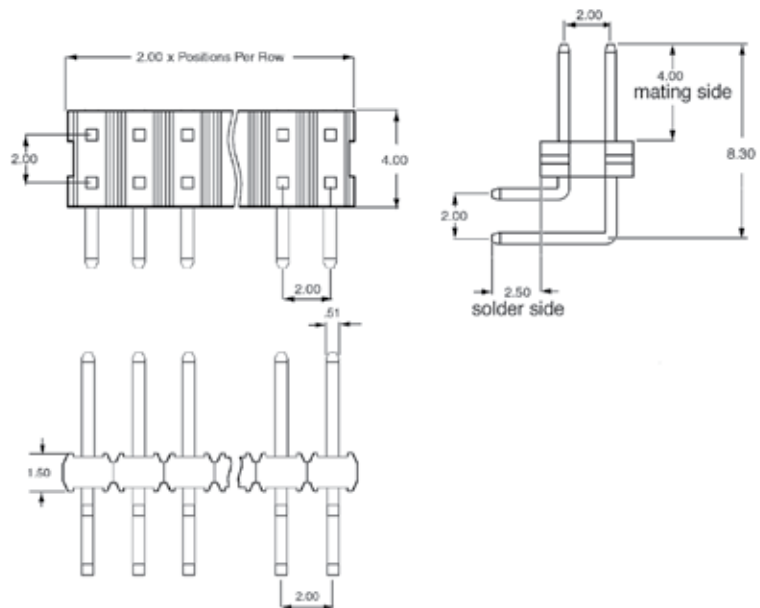

Dimension in mm

TECHNICAL DATA

PHYSICAL

- Housing: High-temperature, black thermoplastic
- Flammability rating: UL 94 V-0
- Pin: Phosphor-bronze
- Plating: Gold/GXT over 1.27 μm (50μ") nickel

ELECTRICAL PERFORMANCE

- Current rating: 3 A continuous
- Insulation resistance: 1x 10⁵ MΩ min.
- Contact resistance: 25 mΩ max.
- Dielectric withstanding voltage: 650 V
- Voltage rating: 200 V.



MECHANICAL PERFORMANCE

- Mating cycles (durability): 100.

OPERATING TEMPERATURE RANGE

- -55°C to +125°C

PACKAGING

- Tubes (04 to 06 pos. packed in box)
- Tape on reel with pick up cap

PROCESSING INFORMATION

- Compatible with wave, vapor-phase, and IR reflow soldering processes

REFERENCE INFORMATION

- File no. E66906
- File no. LR46923
- Product drawing: by 8-digit base part number
- Product specification: DPS-12-011 and GS-12-163
- Application specification: TA-895
- Reflow prfile: TA-842

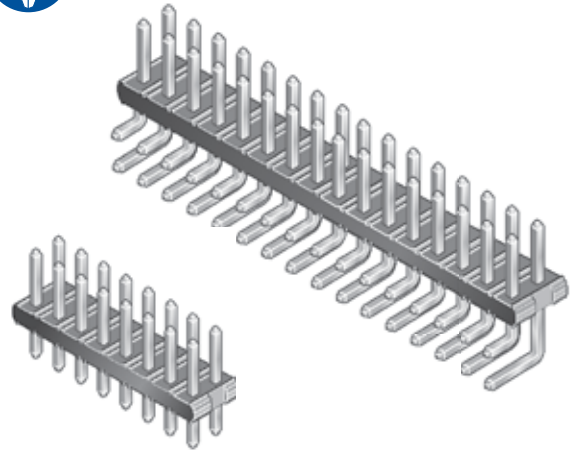

MATING DATA

■ Minitek™ ctw contacts and housings	72
■ Minitek™ Vertical receptacles	60
■ Minitek™ Shunts	62
■ Minitek™ IDC receptacles	76

TYPICAL APPLICATIONS

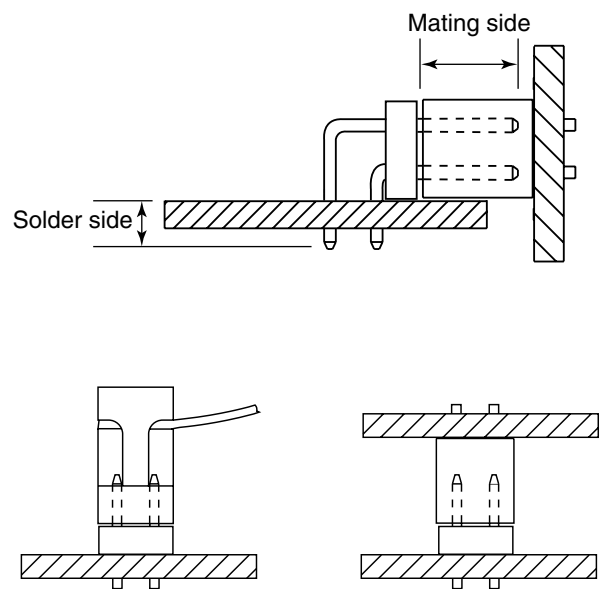

2.00 mm (.079")

Minitek™ Unshrouded Headers, Pin-in-Paste

PART NUMBERS

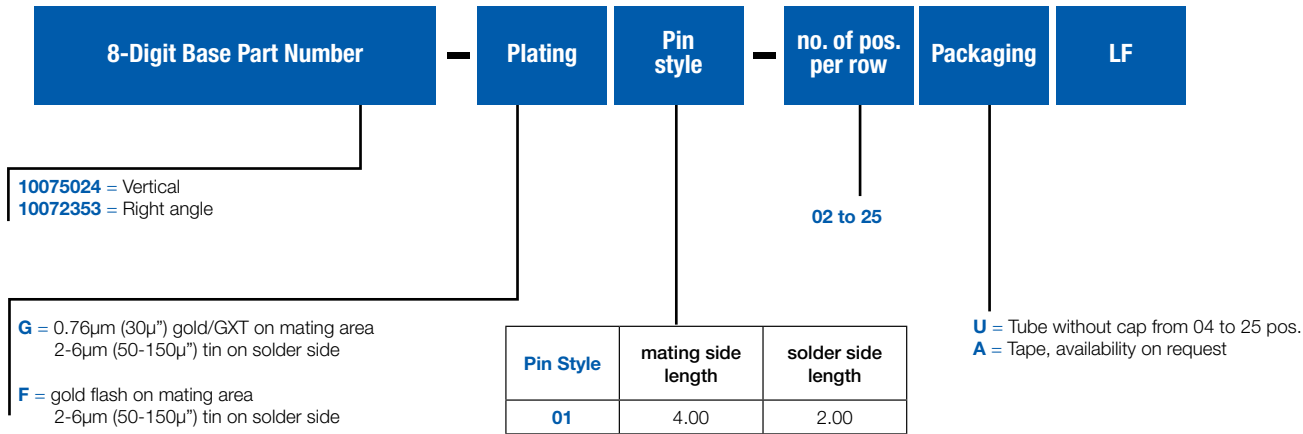

2.00 mm (.079")

PRODUCT

10075024 Vertical

10072353 Right angle

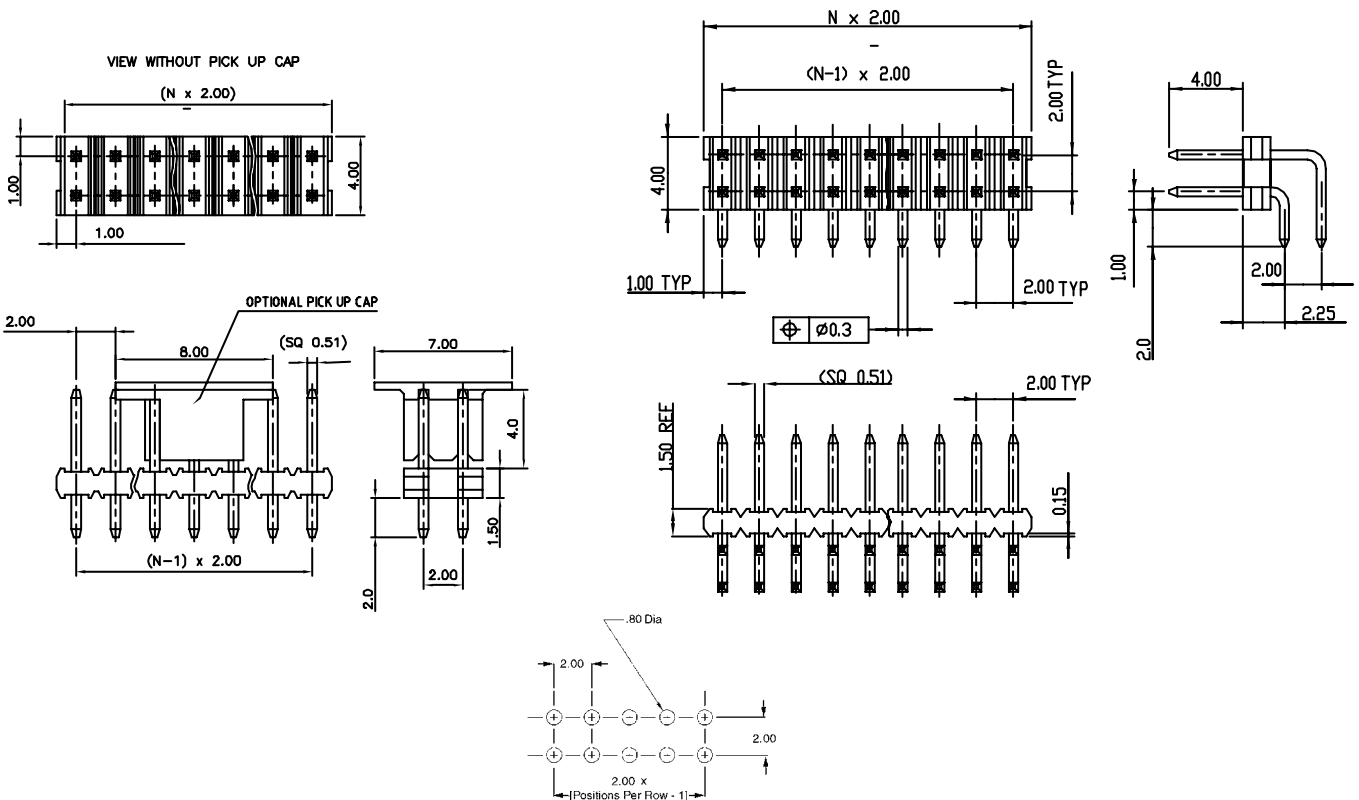

Dimension in mm

Recommended PCB layouts

FEATURES

- Wide variety of stack heights in 0.13 mm increments
- Custom sizes to meet your specific design requirements

TECHNICAL DATA

PHYSICAL

- Housing: High-temperature, black thermoplastic
- Flammability rating: UL 94 V-0
- Pin: Phosphor-bronze
- Plating: Gold over over 1.27 μm (50μ") nickel



ELECTRICAL PERFORMANCE

- Current rating: 2 A continuous
- Insulation resistance: 1x 10⁵ MΩ min.
- Contact resistance: 25 mΩ max.
- Dielectric withstanding voltage: 650 V
- Voltage rating: 200 V.

MECHANICAL PERFORMANCE

- Mating cycles (durability): 100.

OPERATING TEMPERATURE RANGE

- 55°C to +125°C

PACKAGING

- Standard: in bags

PROCESSING INFORMATION

- Compatible with wave, vapor-phase, and IR reflow soldering processes

REFERENCE INFORMATION

- File no. E66906
- File no. LR46923
- Product drawing: 59112, 59132, or 59202
- Product specification: DPS-12-011

RoHs INFORMATION

- This product is RoHs compatible according to the European Union Directive 2002/95/IEC

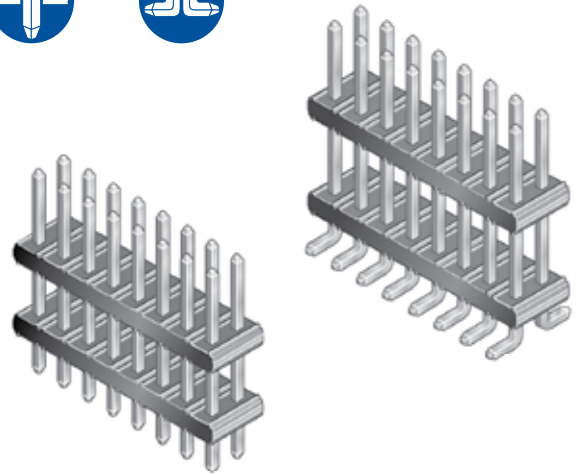

MATING DATA

■ Minitek™ ctw contacts and housings	72
■ Minitek™ Vertical receptacles	60
■ Minitek™ Shunts	62
■ Minitek™ IDC receptacles	76

TYPICAL APPLICATIONS

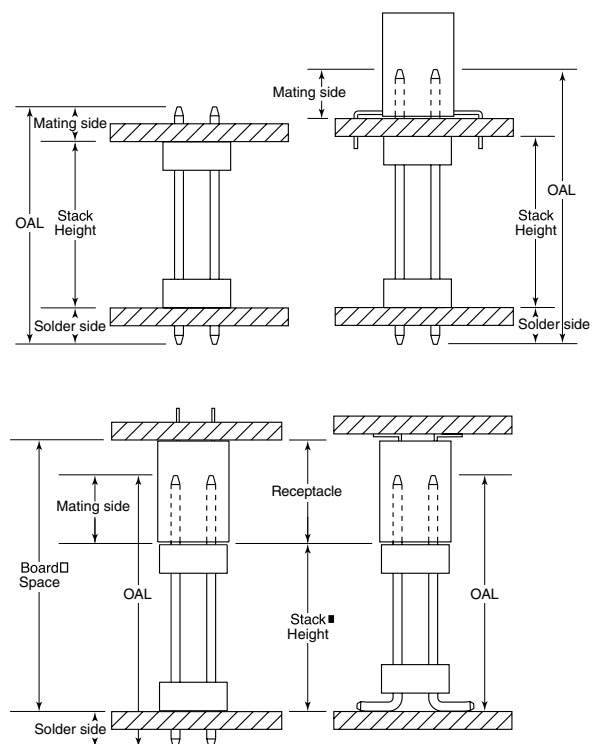

2.00 mm (.079")

Minitek™ Unshrouded Stacking Headers

PART NUMBERS

Compile your own part number using custom dimensions (Please allow for initial setup on our system)



1 = Through Mount (TMT)
2 = Surface Mount (SMT)

1 = 2.50
3 = 3.00
0 = SMT

T = 0,76 μm (30μ")
 Gold on mating side,
 tin on solder side

02 to 25 (TMT)
02 to 25 (SMT)

XXX = mm
 Specify mm
 [e.g., 037 = 03.7 mm]
 in 0.1 mm increments

Pin Style	Overall length (OAL)	
	(TMT) mm	(SMT) mm
22	8.20	6.53
24	9.55	7.87
26	10.19	8.51
28	11.79	10.11
30	13.54	11.86
32	14.10	12.42
34	15.60	13.92
36	17.09	15.42
38	19.08	17.40
40	21.08	19.41

2.00 mm (.079")

PRODUCT

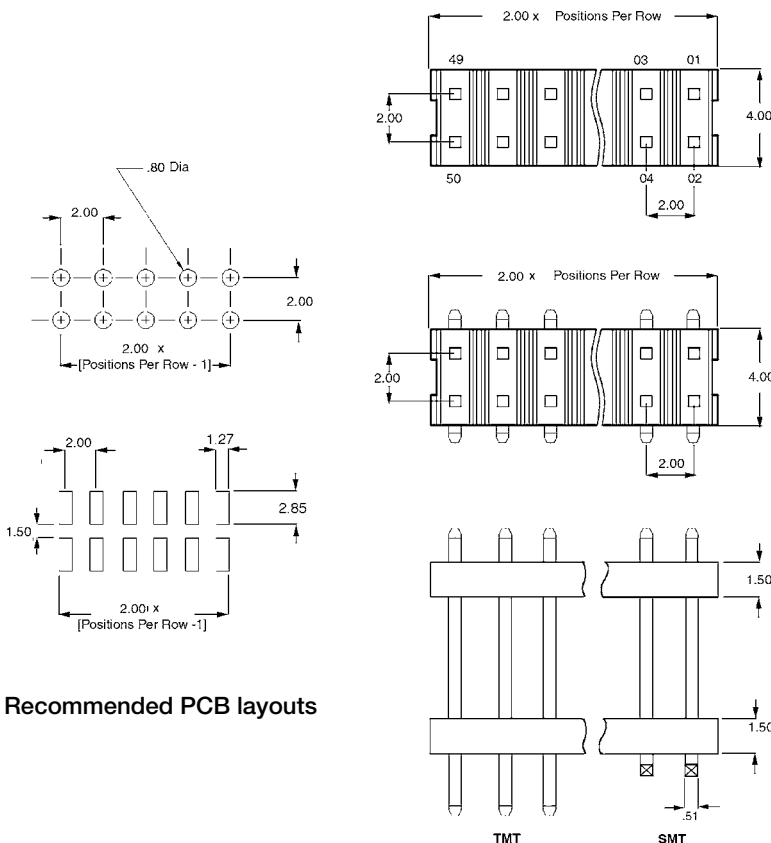

The board spacing is the stack height of this header, plus the height of the receptacle (see application drawings on opposite page)

Recommended PCB layouts

Dimension in mm

FEATURES

- Two housing heights: 2.30 mm, 4.50 mm
- Dual-beam contact design for highly reliable electrical performances

TECHNICAL DATA

PHYSICAL

- Housing: High-temperature, black thermoplastic
- Flammability rating: UL 94 V-0
- Contact: Phosphor-bronze
Beryllium-copper – 63453
- Plating: Gold over 1.27 µm (50 µ") nickel



ELECTRICAL PERFORMANCE

- Current rating: 2 A continuous
- Insulation resistance: 1×10^5 MΩ min.
- Contact resistance: 20 mΩ
25 mΩ - 63453
- Dielectric withstanding voltage: 650 V
- Voltage rating: 200 V.

MECHANICAL PERFORMANCE

- Mating cycles (durability): 25
100 - 63453
- Contact retention to housing: 2.20 N (227 gf) min.
4.90 N (500 gf) min. – 63453
- Insertion force per contact: 1.80 N (184 gf) max.
1.95 N (200 gf) – 63453
- Withdrawal force per contact: 0.20 N (20 gf) min.

OPERATING TEMPERATURE RANGE

- 55°C to +125°C

PACKAGING

- Standard: TMT in Tubes
SMT in Tape-and-reel
- Optional: Tubes (SMT)

PROCESSING INFORMATION

- Compatible with wave, vapor-phase, and IR reflow soldering processes

REFERENCE INFORMATION

- File no. E66906
- File no. LR46923
- Product drawing: by 5-digit base part number
- Product specification: GS-12-008
DPS-12-011 - for 63453

RoHS INFORMATION

- This product is RoHS compatible according to the European Union Directive 2002/95/IEC

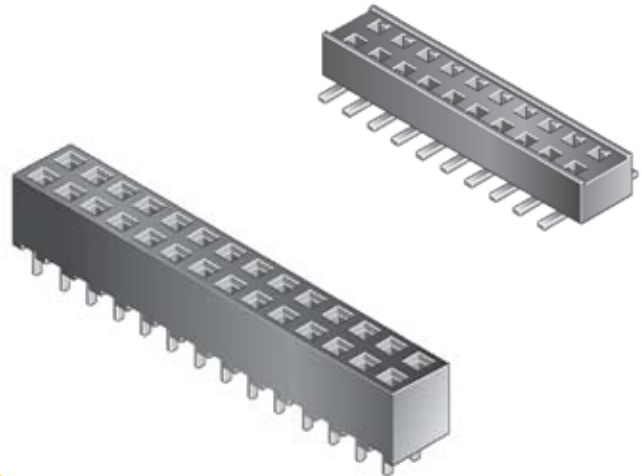

MATING DATA

- Minitek™ Unshrouded headers 52, 54, 58
- Minitek™ Shrouded headers 64, 66

INSERTION DEPTH

- 4.50 mm height: 3.00 mm min. to 4.30 mm max. [provides .381 mm wipe]
- 2.30 mm height – Top Entry: 1.30 mm min. to 2.20 mm max. [provides .381 mm wipe]
- 2.30 mm height – Bottom Entry: 1.40 mm min. to 2.20 mm max. [provides .381 mm wipe] plus board thickness

TYPICAL APPLICATIONS

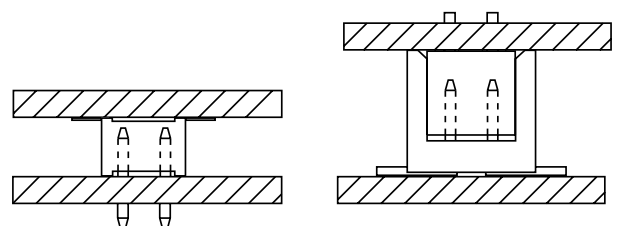
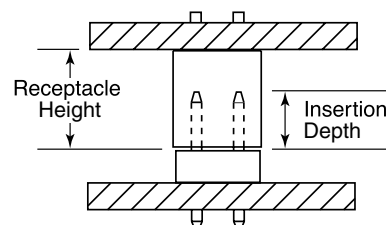

Minitek™ Vertical Receptacles

PART NUMBERS

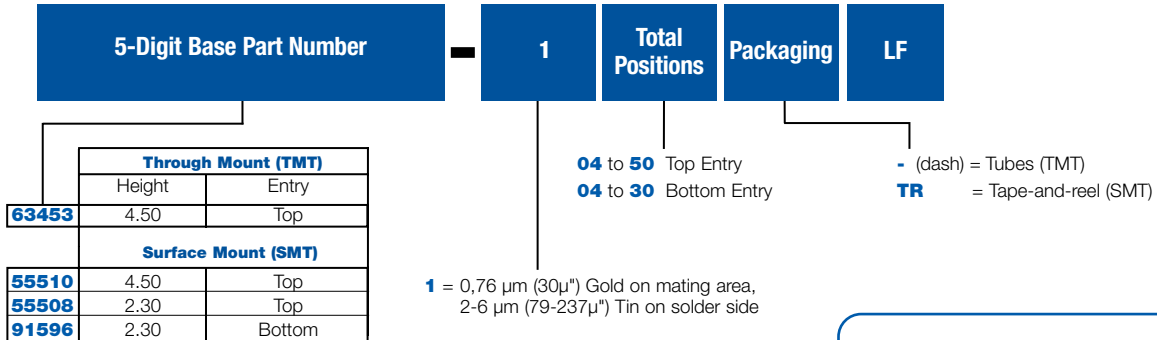

55510 - 1XXTRLF **CORE RANGE**
XX = 04, 06, 08, 10, 12, 16, 20

2.00 mm (.079")

PRODUCT

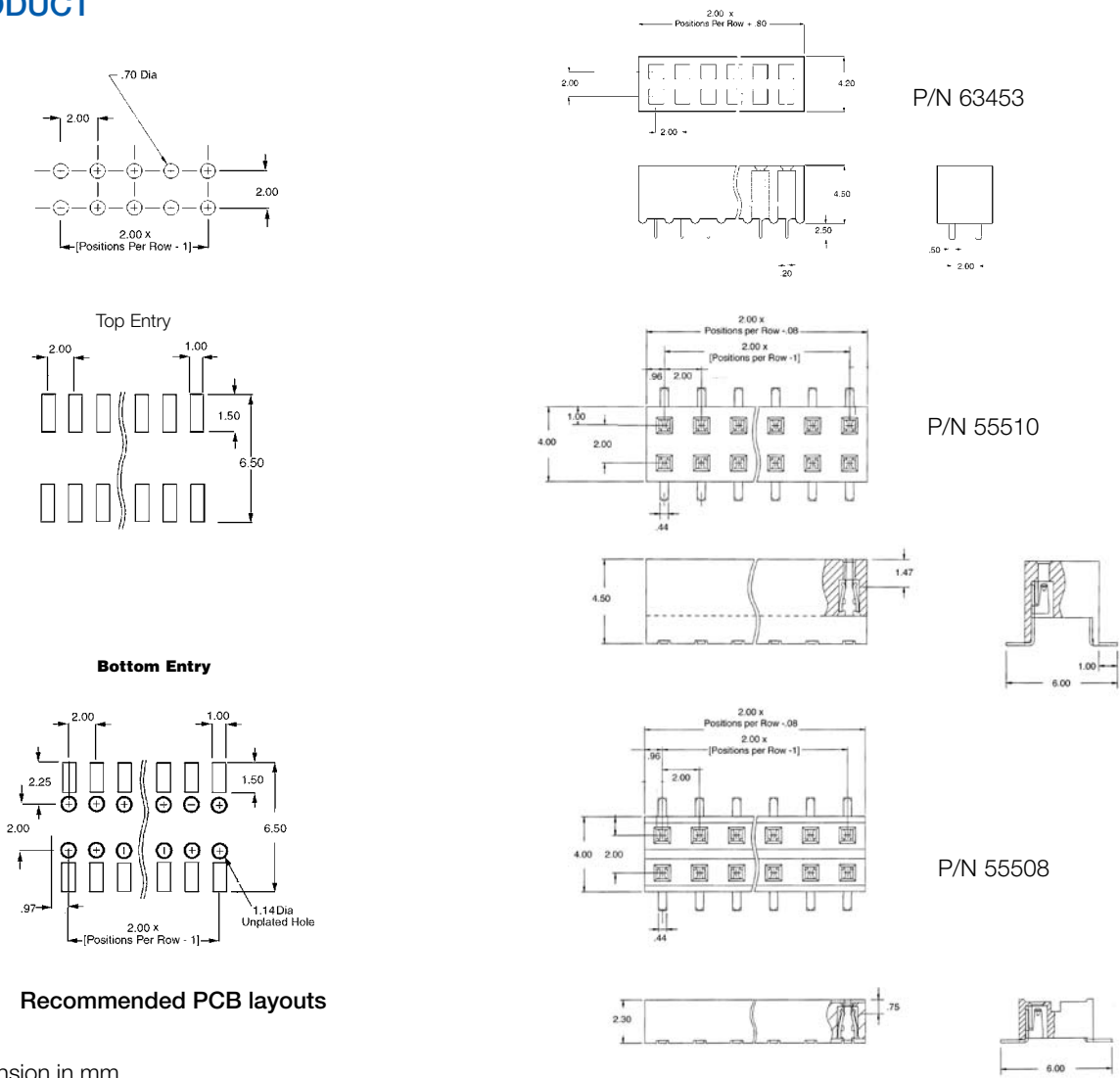

FEATURES

- Early entry, dual-beam contacts provide long wiping action for reliable electrical contact

TECHNICAL DATA

PHYSICAL

- Housing: Black thermoplastic
- Flammability rating: UL 94 V-0
- Contact: Phosphor-bronze
- Plating: Gold or tin-lead over 1.27 µm (50 µ") nickel

ELECTRICAL PERFORMANCE

- Current rating: 1 A continuous
- Insulation resistance: 1x 10⁵ MΩ min.
- Contact resistance: 25 mΩ
- Dielectric withstanding voltage: 650 V
- Voltage rating: 200 V.

MECHANICAL PERFORMANCE

- Mating cycles (durability): 50
- Insertion force per contact: 6.41 N (650 gf) max.
- Withdrawal force per contact: 0.49 N (50 gf) min.

OPERATING TEMPERATURE RANGE

- 55°C to +125°C



PACKAGING

- Bags

PROCESSING INFORMATION

- Compatible with wave, vapor-phase, and IR reflow soldering processes

REFERENCE INFORMATION

-  File no. E66906
-  File no. LR46923
- Product drawing: by 5-digit base part number
- Product specification: DPS-12-012

RoHs INFORMATION

- This product is RoHs compatible according to the European Union Directive 2002/95/IEC

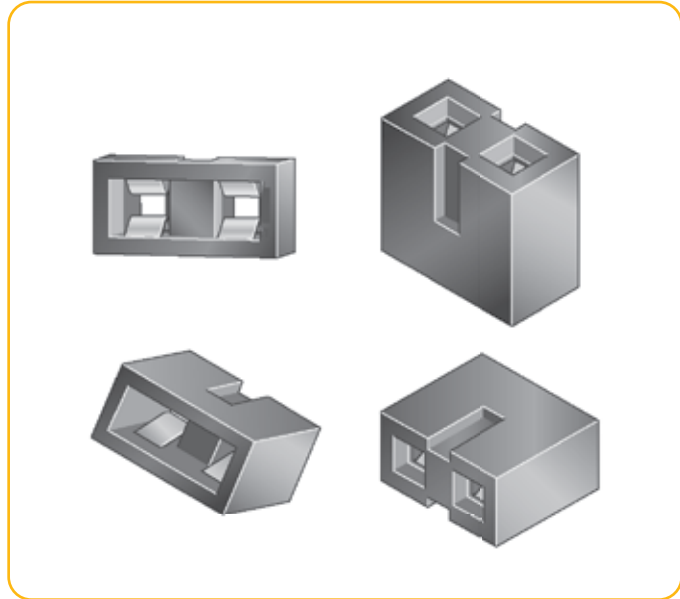

MATING DATA

- Minitek™ Unshrouded headers 52, 54, 58
- Minitek™ Shrouded headers 64, 66

INSERTION DEPTH

- 2.24 mm min. [provides .381 mm wipe]

TYPICAL APPLICATIONS

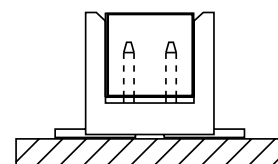
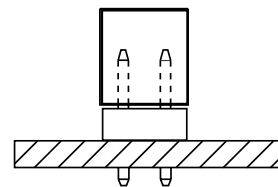

2.00 mm (.079")

Minitek™ Shunts

PART NUMBERS



1 = 0,76 μm (30μ") Gold on mating area,
2-6 μm (79-237μ") Tin on solder side
0 = Gold flash

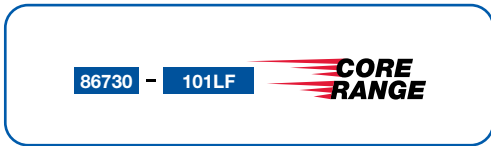

2.00 mm (.079")

PRODUCT

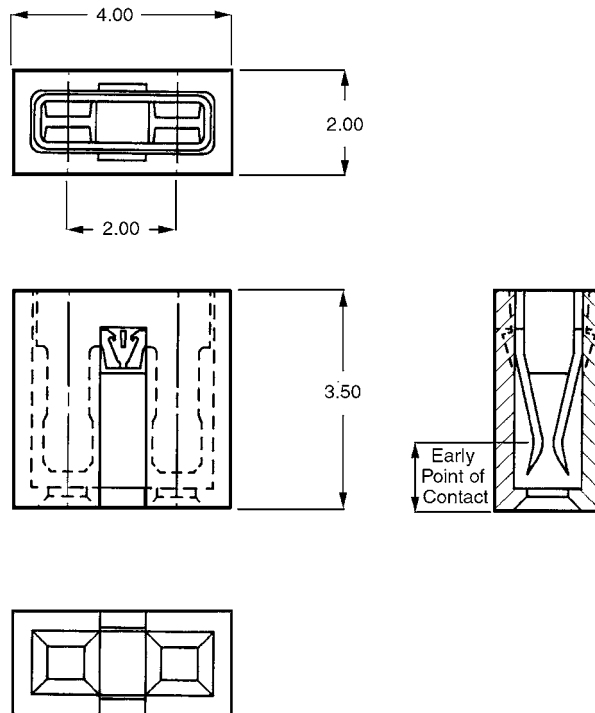

Dimension in mm

FEATURES

- 4-wall design prevents mis-mating
- Selective plating
- Co-planarity 0.1 (SMT)

TECHNICAL DATA

PHYSICAL

- Housing: High temperature, cream-colored thermoplastic
- Flammability rating: UL 94 V-0
- Pin: Phosphor-bronze
- Plating: Gold/GXT over 1.27 μm (50 μ") nickel



ELECTRICAL PERFORMANCE

- Current rating: 2 A continuous
- Insulation resistance: 1x 10⁵ MΩ min.
- Contact resistance: 25 mΩ max.
- Dielectric withstanding voltage: 650 V
- Voltage rating: 200 V.

MECHANICAL PERFORMANCE

- Mating cycles (durability): 100

OPERATING TEMPERATURE RANGE

- 40°C to +125°C

PACKAGING

- Standard: TMT in Tubes (04 to 06 pos. packed in box)
SMT in Tape-and-reel
- Optional: SMT in Tubes (04 and 06 in box)

PROCESSING INFORMATION

- Compatible with wave, vapor-phase, and IR reflow soldering processes

REFERENCE INFORMATION

- File no. E66906
- File no. LR46923
- Product drawing: 98414 or 98424
- Product specification: DPS-12-011 and GS-12-163
- Tape and Reel packaging data TA-884

RoHS INFORMATION

- This product is RoHS compatible according to the European Union Directive 2002/95/IEC

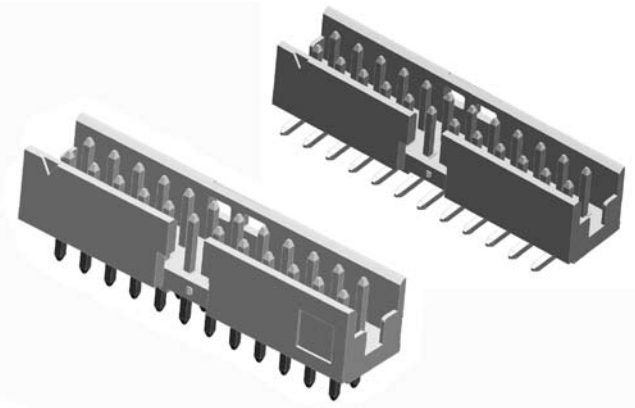

MATING DATA

■ Minitek™ ctw contacts and housings	72
■ Minitek™ Vertical receptacles	60
■ Minitek™ Shunts	62
■ Minitek™ IDC receptacles	76
■ Minitek™ Active latch	74

TYPICAL APPLICATIONS

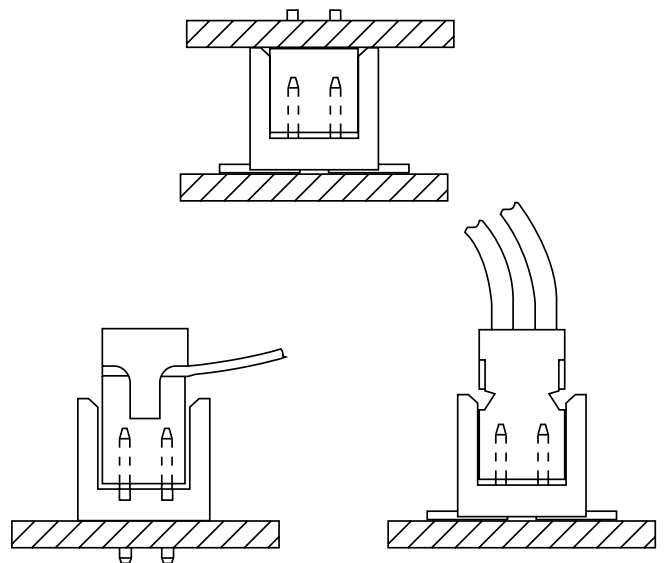

Minitek™ Shrouded Vertical Headers

PART NUMBERS

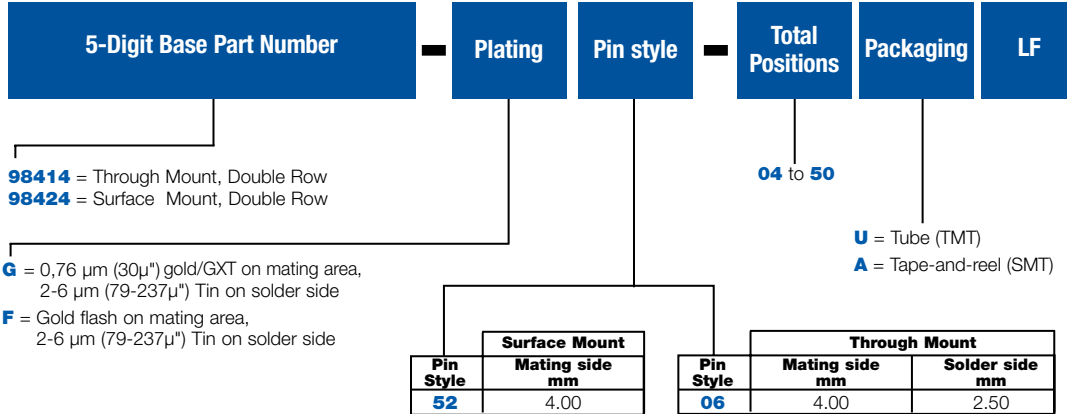

98424 - G 52 - XX ALF

XX = 04, 06, 08, 10, 12, 16, 20

2.00 mm (.079")

PRODUCT

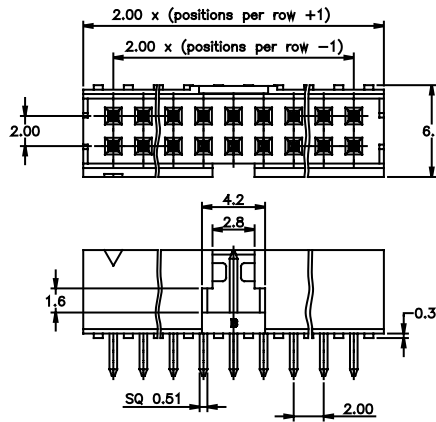
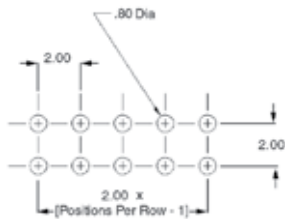

98414 Through mount

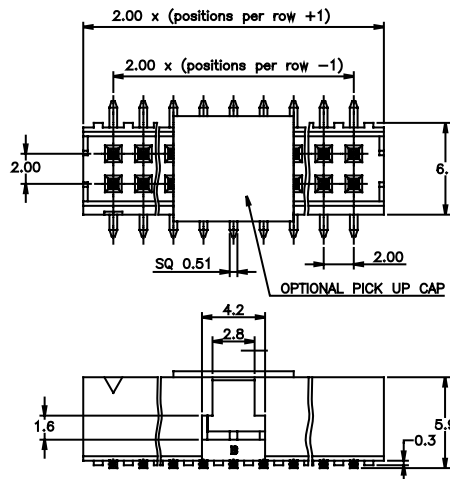
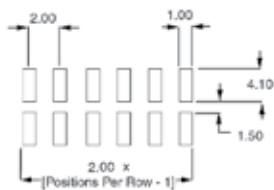
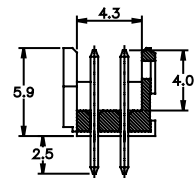

98424 Surface mount

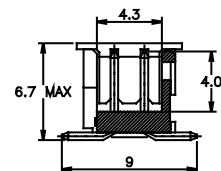

Recommended PCB layouts

Dimension in mm

FEATURES

- 4-wall design prevents mis-mating
- Selective plating

TECHNICAL DATA

PHYSICAL

- Housing: High temperature, cream-colored thermoplastic
- Flammability rating: UL 94 V-0
- Pin: Phosphor-bronze
- Plating: Gold/GXT over 1.27 μm (50 μ") nickel



ELECTRICAL PERFORMANCE

- Current rating: 2 A continuous
- Insulation resistance: 1x 10⁵ MΩ min.
- Contact resistance: 25 mΩ max.
- Dielectric withstanding voltage: 650 V
- Voltage rating: 200 V.

MECHANICAL PERFORMANCE

- Mating cycles (durability): 100

OPERATING TEMPERATURE RANGE

- 40°C to +125°C

PACKAGING

- Standard: Tubes (04 pos. packed in box)

PROCESSING INFORMATION

- Compatible with wave, vapor-phase, and IR reflow soldering processes

REFERENCE INFORMATION

- File no. E66906
- File no. LR46923
- Product drawing: 98464
- Product specification: DPS-12-011 and GS-12-163

RoHS INFORMATION

- This product is RoHS compatible according to the European Union Directive 2002/95/IEC

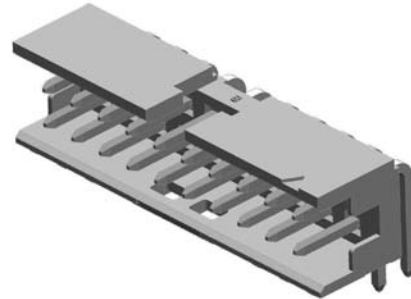

MATING DATA

■ Minitek™ ctw contacts and housings	72
■ Minitek™ Vertical receptacles	60
■ Minitek™ Shunts	62
■ Minitek™ IDC receptacles	76
■ Minitek™ Active latch	74

TYPICAL APPLICATIONS

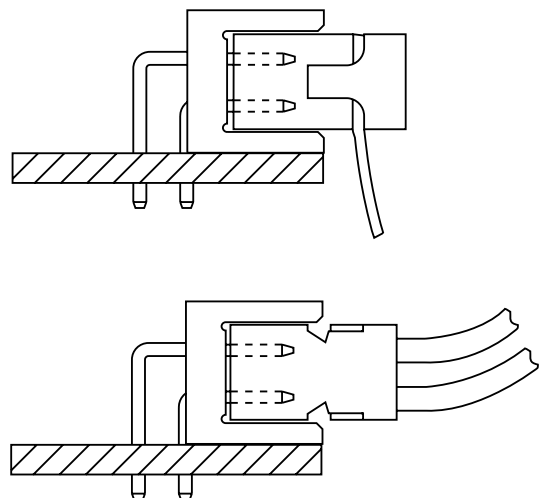

2.00 mm (.079")

Minitek™ Shrouded Right Angle Headers

PART NUMBERS



04 to 50 (Double Row)

- G** = 0,76 μm (30μ") gold/GXT on mating area,
2-6 μm (79-237μ") Tin on solder side
- F** = Gold flash on mating area,
2-6 μm (79-237μ") Tin on solder side

2.00 mm (.079")

PRODUCT

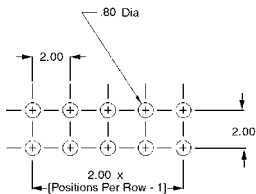

Recommended PCB layouts

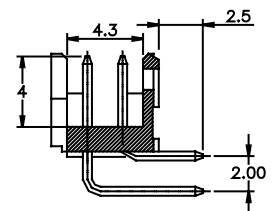
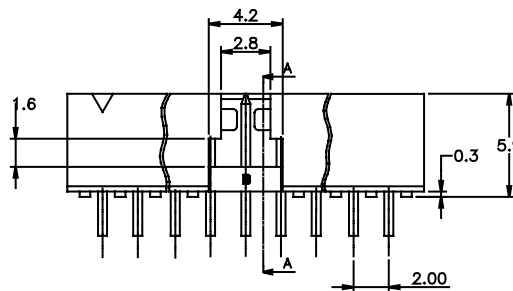
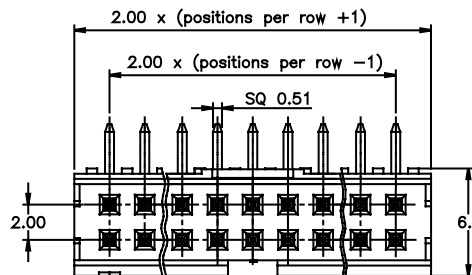

Dimension in mm

TECHNICAL DATA

PHYSICAL

- Housing: High-temperature, black thermoplastic
- Flammability rating: UL 94 V-0
- Pin: Phosphor-bronze
- Plating: Gold/GXT over 1.27 μm (50μ") nickel

ELECTRICAL PERFORMANCE

- Current rating: 3 A continuous
- Insulation resistance: 1x 10⁵ MΩ min.
- Contact resistance: 25 mΩ max.
- Dielectric withstanding voltage: 650 V
- Voltage rating: 200 V.



MECHANICAL PERFORMANCE

- Mating cycles (durability): 100.

OPERATING TEMPERATURE RANGE

- -55°C to +125°C

PACKAGING

- Tubes (04 pos. packed in box)
- Tape on reel with pick up cap

PROCESSING INFORMATION

- Compatible with wave, vapor-phase, and IR reflow soldering processes

REFERENCE INFORMATION

- File no. E66906
- File no. LR46923
- Product drawing: by 8-digit base part number
- Product specification: DPS-12-011 and GS-12-163
- Application specification: TA-895
- Reflow prfile: TA-842

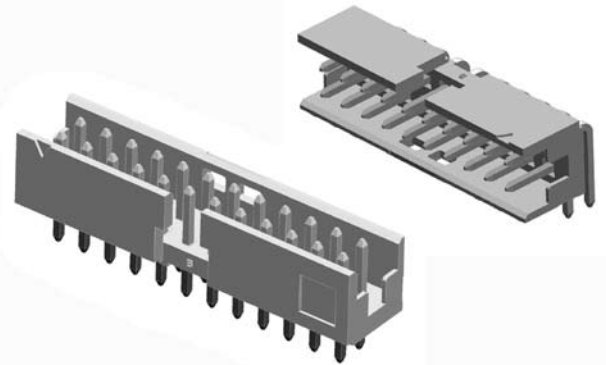

MATING DATA

■ Minitek™ ctw contacts and housings	72
■ Minitek™ Vertical receptacles	60
■ Minitek™ Shunts	62
■ Minitek™ IDC receptacles	76
■ Minitek™ Active latch	74

TYPICAL APPLICATIONS

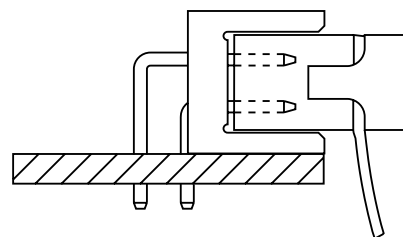
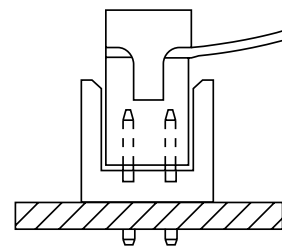

2.00 mm (.079")

Minitek™ Shrouded Headers, Pin-in-Paste

PART NUMBERS



10075025 = Vertical
10072354 = Right angle

04 to 50 (Double row)

G = 0.76µm (30µ") gold/GXT on mating area
2-6µm (50-150µ") tin on solder side

F = gold flash on mating area
2-6µm (50-150µ") tin on solder side

Pin Style	mating side length	solder side length
01	4.00	2.00

U = Tube without cap from 04 to 25 pos.
A = Tape, availability on request

2.00 mm (.079")

PRODUCT

10075025 Vertical

10072354 Right angle

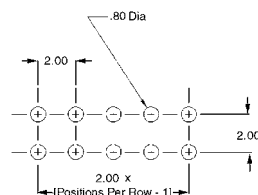
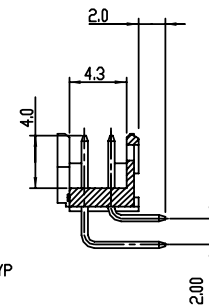
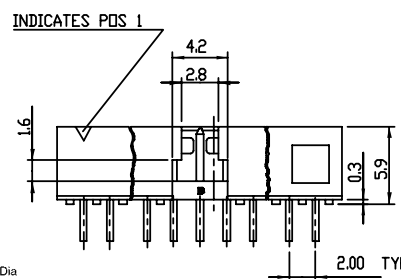
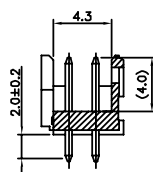
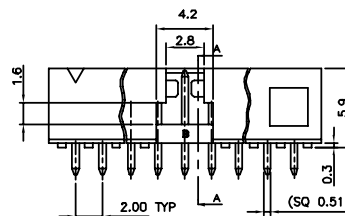
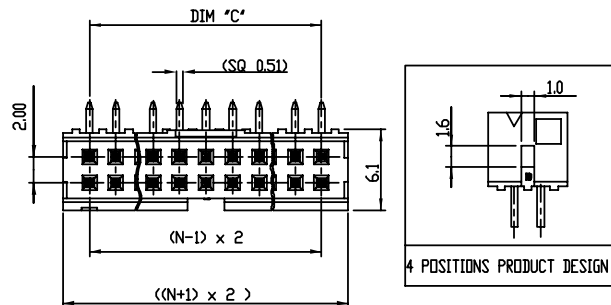
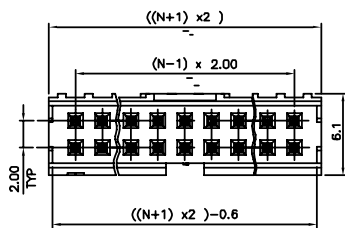

Dimension in mm

Recommended PCB layouts

Shrouded Eject Latch Headers

FEATURES

- Secure latching of cable connector
- Easy ejection when required
- Works with IDC connectors with or without strain relief
- Low profile

TECHNICAL DATA

PHYSICAL

- Housing: Body, cream-colored LCP, Latch black PA
- Flammability rating: UL 94 V-0
- Pin: Phosphor-bronze
- Plating: Gold/GXT over 1.27 μm (50 μm) nickel

ELECTRICAL PERFORMANCE

- Current rating: 2 A continuous
- Insulation resistance: $1 \times 10^5 \text{ M}\Omega$ min.
- Contact resistance: 25 $\text{m}\Omega$ max.
- Dielectric withstanding voltage: 650 V
- Voltage rating: 200 V.

MECHANICAL PERFORMANCE

- Latching retention force: 30 N min.

OPERATING TEMPERATURE RANGE

- 40°C to +125°C

PACKAGING

- Standard: Tubes

PROCESSING INFORMATION

- Compatible with wave, vapor-phase, and IR reflow soldering processes

REFERENCE INFORMATION

- File no. E66906
- File no. LR46923
- Product drawing: 8-digit part number
- Product specification: GS-12-469

RoHs INFORMATION

- This product is RoHs compatible according to the European Union Directive 2002/95/IEC

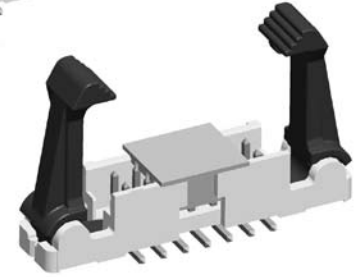
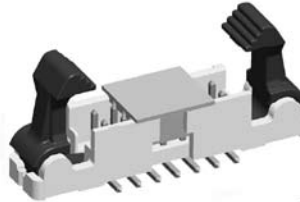

MATING DATA

- Minitek™ IDC receptacles 76

TYPICAL APPLICATIONS

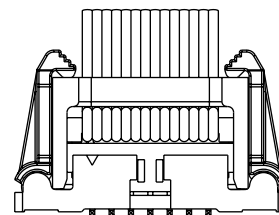

with strain relief
standard latch

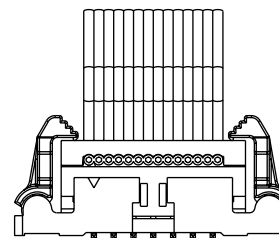

without strain relief
low profile latch

2.00 mm (.079")

Minitek™ Shrouded Eject Latch Headers

PART NUMBERS

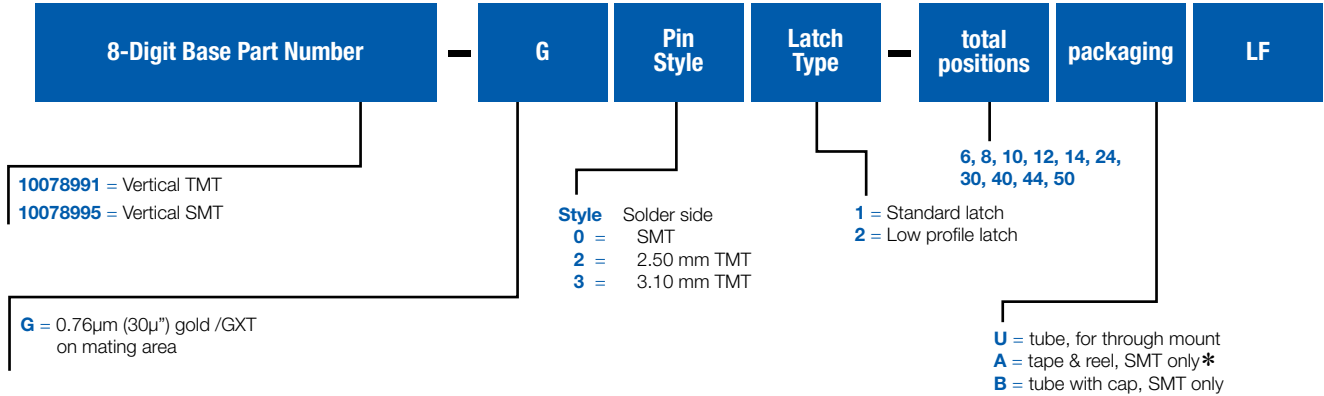

10078991	- G	22	- XX	U	LF	CORE RANGE
10078995	- G	02	- XX	U	LF	
XX = 06, 08, 10, 12,						

* as available

2.00 mm (.079")

PRODUCT

10078991
Vertical TMT

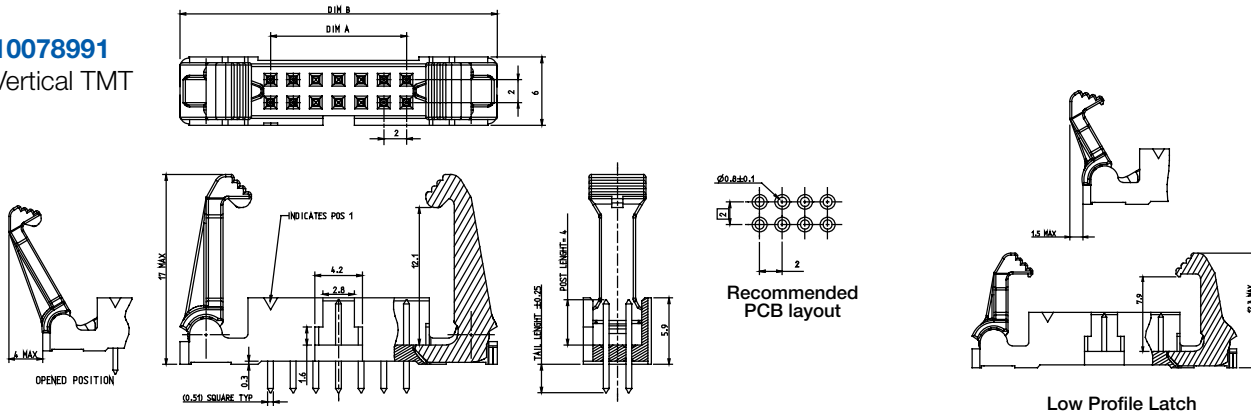

10078995
Vertical SMT

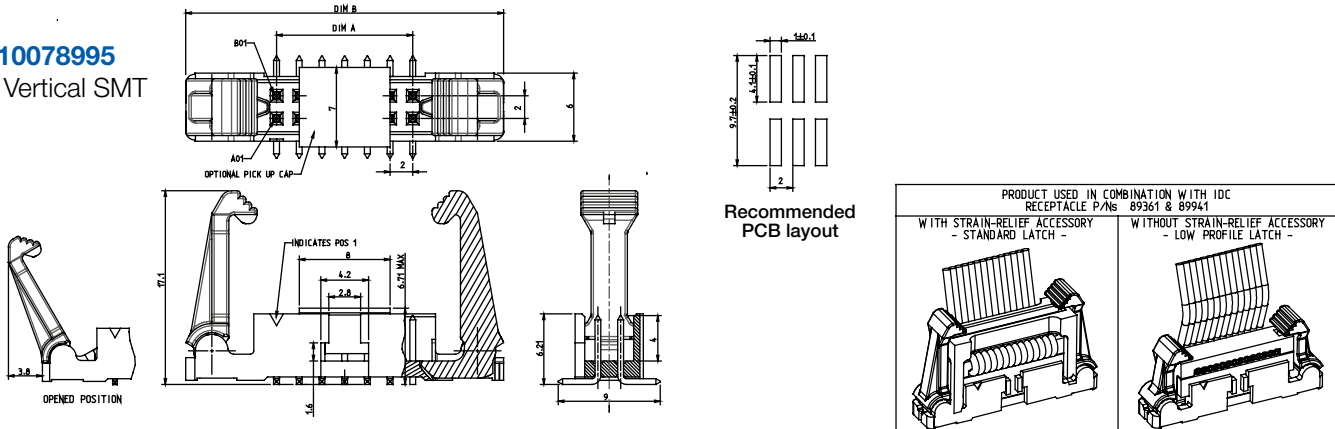

Dimension in mm

Housings and Contacts

FEATURES

- Dual-beam contact design for highly reliable electrical performance
- Latching key assures proper alignment and friction retention

TECHNICAL DATA

PHYSICAL

- Housing: Black thermoplastic
- Flammability rating: UL 94 V-0
- Contact: Phosphor-bronze
- Plating: Gold over 1.27 μm (50 μin) nickel



ELECTRICAL PERFORMANCE

- Current rating: 2 A continuous
- Insulation resistance: $1 \times 10^5 \text{ M}\Omega$ min.
- Contact resistance: 20 $\text{m}\Omega$
- Dielectric withstanding voltage: 650 V
- Voltage rating: 200 V.

MECHANICAL PERFORMANCE

- Mating cycles (durability): 100
- Contact retention to housing: 7.83 N (800 gf) min.
- Mating force per contact: 1.77 N (180 gf) max.
- Unmating force per contact: 0.20 N (20gf) min.

OPERATING TEMPERATURE RANGE

- -40°C to +125°C

PACKAGING

- Reels – Contacts
- Bags – Housings

REFERENCE INFORMATION

- File no. E66906
- File no. LR46923
- Product drawing: 77138 or 77139 – Contact
69307, 90311– Housing
- Product specification: 110-036
- Application specification: 100-006, TA-959

RoHs INFORMATION

- This product is RoHs compatible according to the European Union Directive 2002/95/IEC

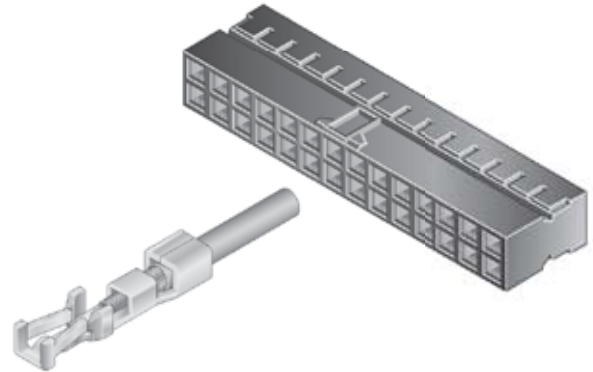

MATING DATA

- Minitek™ Unshrouded headers 52, 54, 58
- Minitek™ Shrouded headers 64, 66

INSERTION DEPTH

- 2.40 mm min. to 3.30 mm max.
[provides .381 mm wipe]
- 3.63 mm min. to 4.00 mm max.
[provides .381 mm wipe in housing]

TYPICAL APPLICATIONS

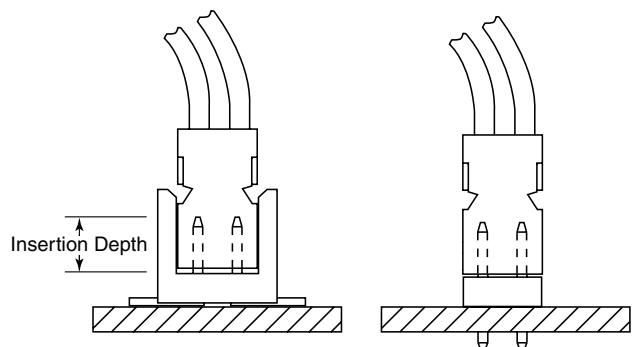

2.00 mm (.079")

Minitek™ Crimp-to-wire Housings and Contacts

PART NUMBERS

Contacts



26 AWG to 30 AWG

1 = 0,76 μm (30μ") Gold on mating area
 0 = Gold flash

Housings



04 to 50 (Double Row)

77138	101LF	
10087010	0XXLF	

XX = 04, 06, 08, 10, 12, 16, 20

2.00 mm (.079")

PRODUCT

Contacts

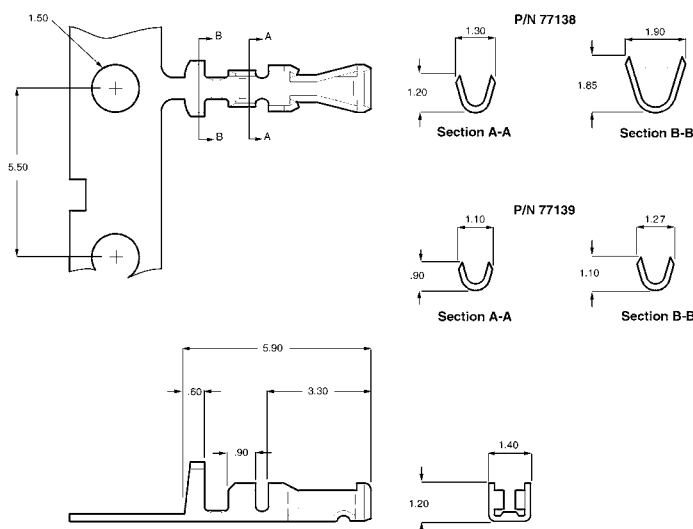

Dimension in mm

Housings

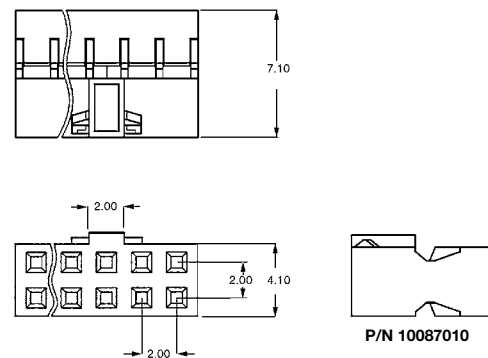

Housings, Active latch

FEATURES

- ▶ Latching retention 15/25 N (depending on size) due to latch alone
- ▶ Latches with audible click
- ▶ Mates with standard Minitek headers
- ▶ Latch can be released and parts unmated

TECHNICAL DATA

PHYSICAL

- ▶ Housing: Polyamide, black
- ▶ Flammability rating: UL 94 V-0

ELECTRICAL PERFORMANCE

- ▶ Insulation resistance: 1×10^5 M Ω min.
- ▶ Dielectric withstanding voltage: 500 V

MECHANICAL PERFORMANCE

- ▶ Latching retention force: 15 N min. (for 2x3 and 2x4 pos)
- ▶ Latching retention force: 25 N min. (for 2x5 and 2x25 pos)



OPERATING TEMPERATURE RANGE

- ▶ -55°C to +125°C

PACKAGING

- ▶ Standard: Plastic bags

REFERENCE INFORMATION

- ▶  File no. E66906
- ▶  File no. LR46923
- ▶ Product drawing: 8-digit part number
- ▶ Product specification: GS-12-415

RoHs INFORMATION

- ▶ This product is RoHs compatible according to the European Union Directive 2002/95/IEC

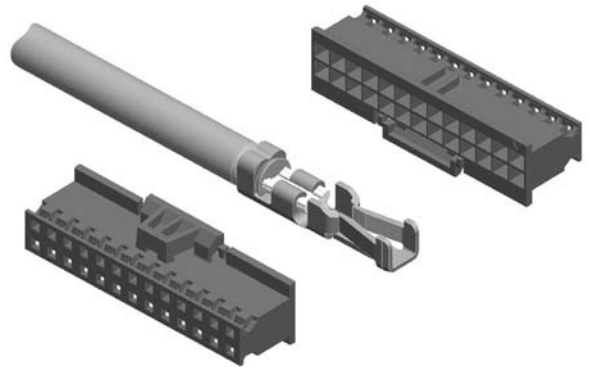

MATING DATA

- | | |
|-----------------------------|------------|
| ▶ Minitek™ Shrouded headers | 64, 66, 68 |
| ▶ Minitek™ CTW contacts | 72, 74 |

TYPICAL APPLICATIONS

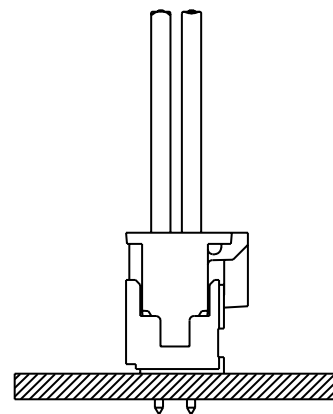

2.00 mm (.079")

Minitek™ Crimp-to-wire Housings, Active latch

PART NUMBERS

Contacts

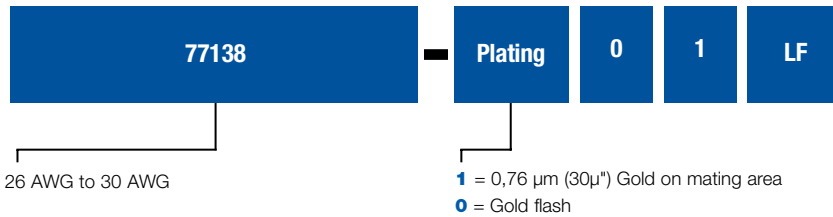

Housings

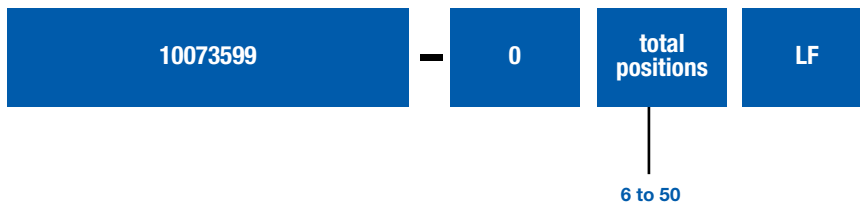

77138	-	101LF	CORE RANGE
10073599	-	0XXLF	

XX = 04, 08, 10, 12, 16, 20

2.00 mm (.079")

PRODUCT

Contacts

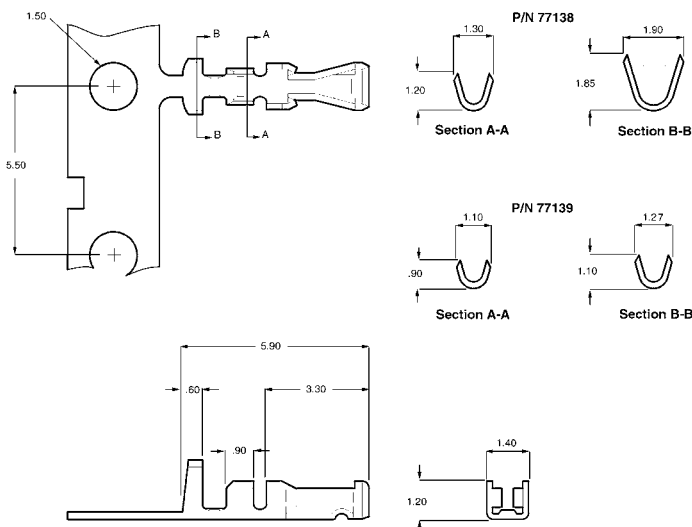

Housings

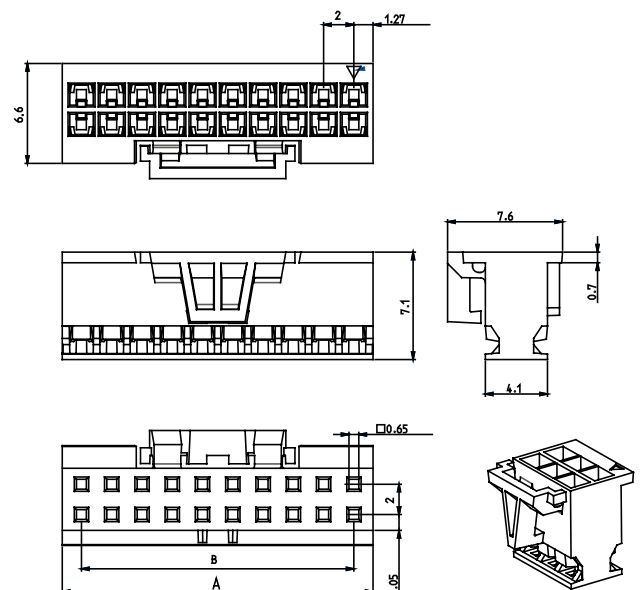

Dimension in mm

DESIGN FOR 10073599-006LF & 10073599-008LF ONLY

FEATURES

- ▶ Early entry, single-beam contacts provide long wiping action for reliable electrical contact
- ▶ Center key polarization and friction latch options

TECHNICAL DATA

PHYSICAL

- ▶ Housing: Black thermoplastic
- ▶ Flammability rating: UL 94 V-0
- ▶ Contact: Phosphor-bronze
- ▶ Plating: Gold over 1.27 μm (50 μ") nickel



ELECTRICAL PERFORMANCE

- ▶ Current rating: 1 A continuous
- ▶ Insulation resistance: 1x 10⁵ MΩ min.
- ▶ Contact resistance: 30 mΩ
- ▶ Dielectric withstanding voltage: 650 V

MECHANICAL PERFORMANCE

- ▶ Mating cycles (durability): 100

OPERATING TEMPERATURE RANGE

- ▶ -40°C to +105°C

PACKAGING

- ▶ Tubes

REFERENCE INFORMATION

- ▶ File no. E66906
- ▶ File no. LR46923
- ▶ Product drawing: 89947 or 89361
- ▶ Product specification: BUS-12-115

RoHS INFORMATION

- ▶ This product is RoHS compatible according to the European Union Directive 2002/95/IEC



MATING DATA

- ▶ Minitek™ Unshrouded headers 52, 54, 58
- ▶ Minitek™ Shrouded headers 64, 66

INSERTION DEPTH

- ▶ 2.55 mm min. to 4.57 mm max.
[provides .381 mm wipe]

TYPICAL APPLICATIONS

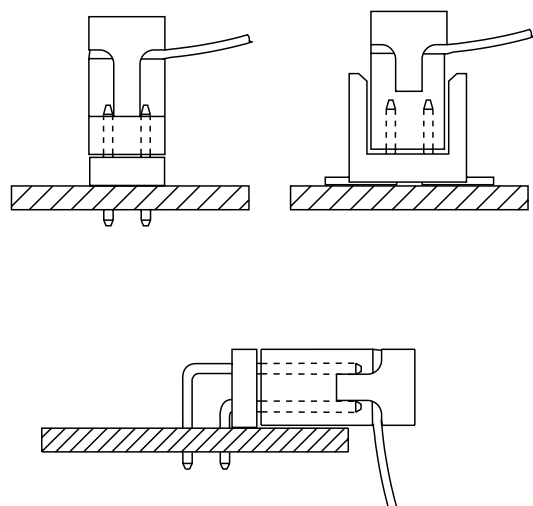

2.00 mm (.079")

Minitek™ IDC Receptacle

PART NUMBERS

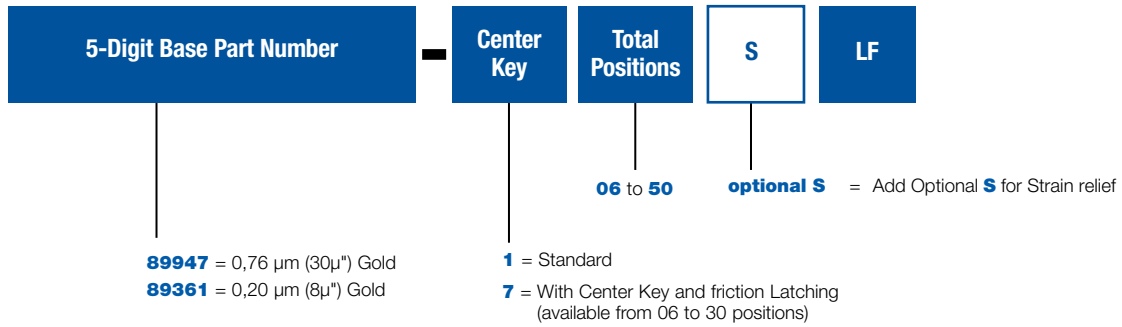

89361 - 7XXLF **CORE RANGE**
 XX = 06, 08, 10, 12, 16, 20

2.00 mm (.079")

PRODUCT

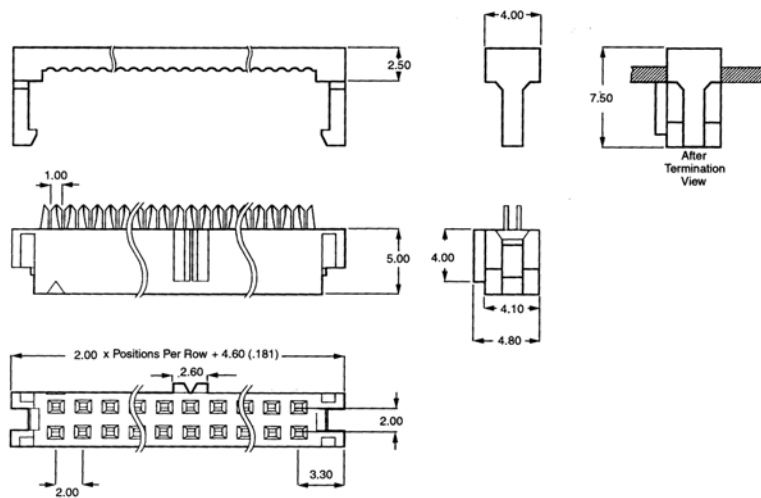

Dimension in mm

If you need something more than the standard parts in this catalog, Basics+ has many more options to help you in your design process. Here are just some examples.

▀ Locating pins on SMT headers



▀ Polarized (missing) positions



▀ Kinked legs



▀ Press-fit pins

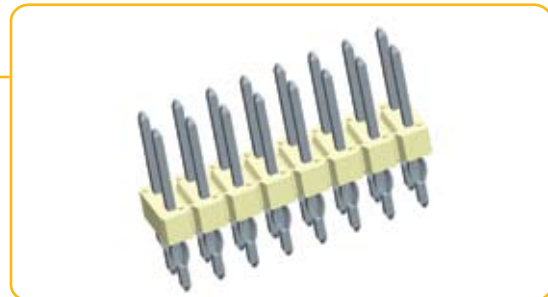

▀ Add-on latches for headers

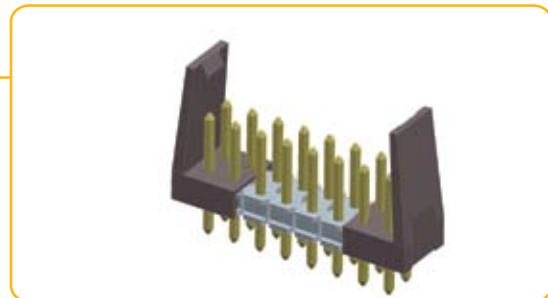

Wide body headers



Crimp-to-wire pin

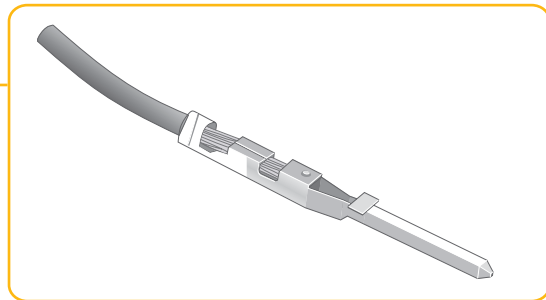

Printed housings



Additional plating options

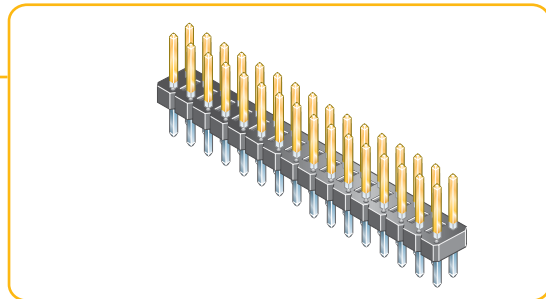

Pin-in-paste headers

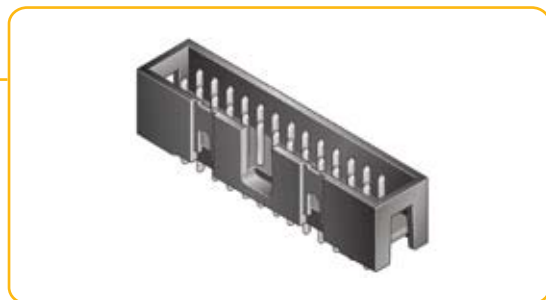

Visit: www.fci.com/basicdesign to specify your design need



DUBOX™ CRIMP-TO-WIRE CONTACTS

Contact Description	Wire size	Hand Tool	Mini-Applicator (right to left feeding)	Mini-Applicator (left to right feeding)	Repair Tool
Dubox	AWG 20-22	RCY21235	RCY20027	RCY20017	HT 272
Dubox	AWG 22-24	RCY21234	RCY20008	RCY20029	HT 272
Dubox	AWG 26-30	RCY21234	RCY20008	RCY20029	HT 272
Small insulation Dubox	AWG 28-32	-	RCY20028		HT 272

PV™ CRIMP-TO-WIRE CONTACTS

Contact Description	Wire size	Hand Tool	Mini-Applicator	Repair Tool
Standard Mini-PV	AWG 18-20	HT-0073	133867-104	HT-0080
Standard Mini-PV	AWG 22-26	HT-0095	133867-105	HT-0080
Standard Mini-PV	AWG 28-32	HT-0095	133867-106	HT-0080
Standard Mini-PV	AWG 34-36	HT-0112	133867-108	HT-0080
Small Insulation PV	AWG 22-26	HT-207	-	HT-0080
Small Insulation PV	AWG 28-32	HT-217	-	HT-0080

MINITEK™ CRIMP-TO-WIRE CONTACTS

Contact Description	Wire size	Hand Tool	Mini-Applicator	Repair Tool
Minitex	AWG 26-30	RCY21151	155250-101	HT-0080
Minitex	AWG 32-36	RCY21152	155250-102	HT-0080

Application Equipment

BergStik® AND Bergstrip®

- ▶ Manual cutting tool: HT 320
- ▶ Automatic cutting machine for Bergstrip: BSS-300

Quickie® IDC

- ▶ Manual flat cable cutter: HT 209
- ▶ Quickie assembly hand tool: HT 210
- ▶ Many other variations of manual, semi- automatic and automatic tools available upon request.

Minitek® IDC

- ▶ Manual flat cable cutter: HT 209
- ▶ Hand Press: QP-104

Where to get your tooling

These toolings and more detailed advice, pricing, availability etc. are available through your distributor or from the following suppliers:

▶ Americas

Phone: 1-800-843-6911
E-mail: doug.sheaffer@fciconnect.com

▶ Europe

Föhrenbach Application Tooling N.V.
Phone: +32 3 216 19 98
Email : application.tooling@foehrenbach.be

▶ Asia

Phone: +65 549 6666
E-mail: fcising_sales@fciconnect.com

BASE PART NUMBER	PAGE	BASE PART NUMBER	PAGE
47437	39	76385	31
47439	39	77138	73, 75
47457	39	77311	9, 13
47564	39	77313	9, 13
47565	39	77315	15
47566	39	77317	15
48047	39	78207	37
48048	39	78208	37
48276	39	86730	63
52601	45	87606	23
54XXX	19	89361	77
55508	61	89882	29
55510	61	89883	29
57102	53	89891	23
57202	53	89898	27
59112	59	89947	77
59132	59	91596	61
59202	59	91601	27
63453	61	91614	27
65039	41	91615	27
65043	41	91618	27
65239	35	95278	9
65240	35	98414	65
65846	41	98423	55
67996	11	98424	65
68000	11	98464	67
68015	17	10056844	45
68020	17	10056845	45
68786	21	10072353	57
69145	21	10073599	75
69167	37	10075024	57
69168	37	10075025	69
69830	51	10075324	69
71600	49	10078991	71
71607	29	10078995	71
71609	29	10087010	73
71918	47		
71920	23		
71922	47		
71991	25		
75867	43		
75869	43		
75915	23		
76341	25		
76342	25		
76347	33		
76357	33		
76382	31		
76383	31		
76384	31		

A large rectangular area with rounded corners, outlined in blue, containing 25 horizontal blue lines for writing notes.

For more information about e-catalog or FCI
sales offices, headquarters, agents and local distributors,
visit www.fciconnect.com



For more information please contact: elxcommunications@fci.com

Mouser Electronics

Authorized Distributor

Click to View Pricing, Inventory, Delivery & Lifecycle Information:

FCI:

[67996-406](#) [67996-408](#) [67996-416](#) [67996-426](#) [68000-300H](#) [68000-300HLF](#) [67996-404H](#) [69145-308](#) [95293-105-08LF](#) [67996-372HLF](#) [67996-402H](#) [67996-406H](#) [67996-416H](#) [67996-418](#) [67996-420](#) [67996-432H](#) [67996-434H](#) [67996-436](#) [67996-440](#) [67996-448](#) [67996-460](#) [71920-311CLF](#) [71920-330CLF](#) [71991-316HLF](#) [71991-409NLF](#) [77315-103-09LF](#) [77315-401-04LF](#) [77315-407-13LF](#) [54111-108041200LF](#) [54111-109201800LF](#) [54111-112162500LF](#) [54111-809071800LF](#) [54111-809201800LF](#) [54111-810031800LF](#) [54112-106200800LF](#) [54112-107201450LF](#) [54112-108081200LF](#) [54112-109160800LF](#) [54112-110101500LF](#) [54112-110441900LF](#) [54112-112401850LF](#) [54112-801160800LF](#) [54112-803500800LF](#) [54112-804500800LF](#) [54112-807081400LF](#) [54112-809101700LF](#) [54112-809141800LF](#) [54112-810241800LF](#) [54112-810621500LF](#) [54112-108321350LF](#) [54111-110022050LF](#) [54111-116102350LF](#) [54111-116102450LF](#) [54112-103060800LF](#) [54112-106141150LF](#) [54112-809062000LF](#) [54112-108121200LF](#) [54112-112402000LF](#) [54111-108061450LF](#) [54111-108361200LF](#) [54111-810111350LF](#) [54112-109141800LF](#) [77317-418-10LF](#) [95293-402-10LF](#) [54112-812262450LF](#) [77315-102-03LF](#) [95293-401A05LF](#) [54112-108501600LF](#) [54112-109501850LF](#) [54112-111121850LF](#) [54112-806081050LF](#) [71991-322HLF](#) [77314-450LF](#) [77315-113-18LF](#) [54111-106040850LF](#) [54111-107020850LF](#) [54111-107040850LF](#) [54111-108031250LF](#) [54111-108081000LF](#) [54111-110200800LF](#) [54111-802240800LF](#) [54111-804050800LF](#) [54111-804051050LF](#) [54112-106081100LF](#) [54112-106201050LF](#) [54112-106341050LF](#) [54112-107401300LF](#) [54112-109062000LF](#) [54112-109081700LF](#) [54112-110401600LF](#) [54112-803080900LF](#) [54112-804101050LF](#) [54112-805220850LF](#) [54112-806261150LF](#) [54112-810061400LF](#) [54112-810621400LF](#) [54112-811121900LF](#) [54121-105041000LF](#) [54121-108021650LF](#) [54121-108081500LF](#)