

SN74LV8154 Dual 16-Bit Binary Counters With 3-State Output Registers

Check for Samples: [SN74LV8154](#)

1 Features

- Can Be Used as Two 16-Bit Counters or a Single 32-Bit Counter
- 8 bit counter read bus
- 2-V to 5.5-V V_{CC} Operation
- Maximum t_{pd} of 25 ns at 5 V (RCLK to Y)
- Typical V_{OLP} (Output Ground Bounce) < 0.7 V at $V_{CC} = 5$ V, $T_A = 25^\circ\text{C}$
- Typical V_{OHV} (Output V_{OH} Undershoot) > 4.4 V at $V_{CC} = 5$ V, $T_A = 25^\circ\text{C}$
- I_{off} Supports Partial-Power-Down Mode Operation
- Latch-Up Performance Exceeds 250 mA Per JESD 17
- ESD Protection Exceeds JESD 22
 - 2000-V Human Body Model (A114-A)
 - 200-V Machine Model (A115-A)
 - 1000-V Charged-Device Model (C101)

2 Applications

- Up Counters
- Dual Up Counters

3 Description

The SN74LV8154 device is a dual 16-bit binary counter with 3-state output registers, designed for 2-V to 5.5-V V_{CC} operation.

The counters have dedicated clock inputs. The counters share a clocked storage register to sample and save the counter contents. Both counters share an asynchronous clear input. The 32-bit storage register can be mapped on the output bus 8-bits at a time. Four bus reads are needed to access the contents of both stored counts. The two counters can be chained by connecting $\overline{\text{CLKBEN}}$ to $\overline{\text{RCOA}}$. All clocks are positive edge triggered. All other inputs are active low.

This device is fully specified for partial-power-down applications using I_{off} . The I_{off} circuitry disables the outputs, preventing damaging current backflow through the device when it is powered down.

Device Information⁽¹⁾

PART NUMBER	PACKAGE	BODY SIZE (NOM)
SN74LV8154N	PDIP (20)	6.50 mm x 4.40 mm
SN74LV8154PW	TSSOP (20)	26.92 mm x 6.35 mm

(1) For all available packages, see the orderable addendum at the end of the data sheet.

Simplified Schematic

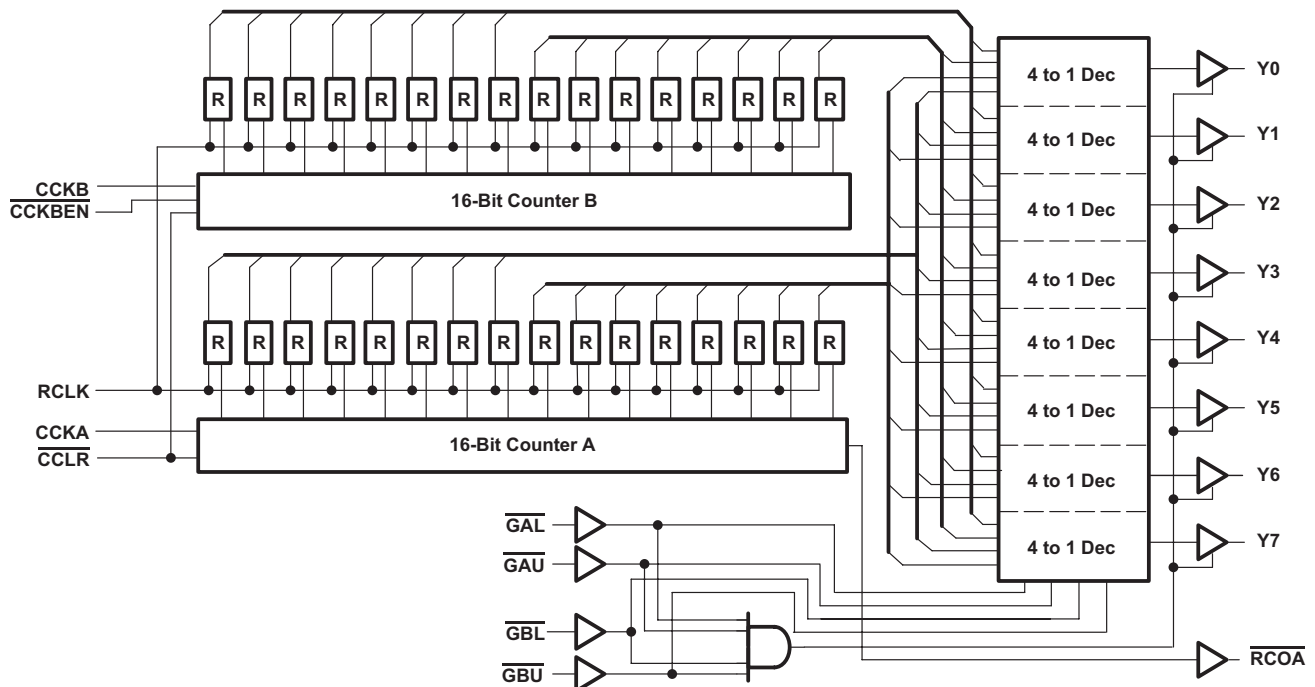

Table of Contents

1 Features	1	8.1 Overview	9
2 Applications	1	8.2 Functional Block Diagram	9
3 Description	1	8.3 Feature Description	9
4 Revision History	2	8.4 Device Functional Modes	10
5 Pin Configuration and Functions	3	9 Application and Implementation	11
6 Specifications	4	9.1 Application Information	11
6.1 Absolute Maximum Ratings	4	9.2 Typical Application	11
6.2 ESD Ratings	4	10 Power Supply Recommendations	13
6.3 Recommended Operating Conditions	4	11 Layout	13
6.4 Thermal Information	5	11.1 Layout Guidelines	13
6.5 Electrical Characteristics	5	11.2 Layout Example	13
6.6 Timing Requirements	5	12 Device and Documentation Support	14
6.7 Switching Characteristics - $V_{CC} = 3.3 V \pm 0.3 V$	6	12.1 Documentation Support	14
6.8 Switching Characteristics $V_{CC} = 5 V \pm 0.5 V$	6	12.2 Community Resources	14
6.9 Noise Characteristics	6	12.3 Trademarks	14
6.10 Typical Characteristics	7	12.4 Electrostatic Discharge Caution	14
7 Parameter Measurement Information	8	12.5 Glossary	14
8 Detailed Description	9	13 Mechanical, Packaging, and Orderable Information	14

4 Revision History

NOTE: Page numbers for previous revisions may differ from page numbers in the current version.

Changes from Original (August 2004) to Revision A

Page

• Added <i>Pin Configuration and Functions</i> section, <i>Storage Conditions</i> table, <i>ESD Ratings</i> table, <i>Feature Description</i> section, <i>Device Functional Modes</i> , <i>Application and Implementation</i> section, <i>Power Supply Recommendations</i> section, <i>Layout</i> section, <i>Device and Documentation Support</i> section, and <i>Mechanical, Packaging, and Orderable Information</i> section	1
• Removed <i>Ordering Information</i> table	1

5 Pin Configuration and Functions

N or PW Package
20-Pin PDIP or TSSOP
Top View

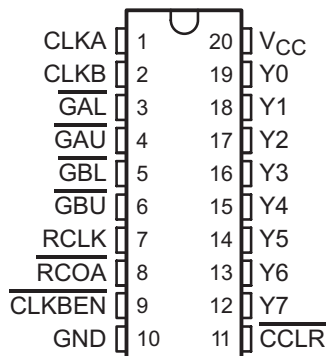

Pin Functions

PIN		I/O	DESCRIPTION
NAME	NO.		
$\overline{\text{CCLR}}$	11	I	Clock clear, asynchronous active-low clear for both counters
CLKA	1	I	Clock A, rising edge count clock
CLKB	2	I	Clock B, rising edge count clock
$\overline{\text{CLKBEN}}$	9	I	Clock B enable, active-low allows clocking for counter B; connect to $\overline{\text{RCOA}}$ for 32-bit counter.
$\overline{\text{GAL}}$	3	I	Gate A lower byte, active-low puts lower byte of stored counter A on the Y bus.
$\overline{\text{GAU}}$	4	I	Gate A upper byte, active-low puts upper byte of stored counter A on the Y bus.
$\overline{\text{GBL}}$	5	I	Gate B lower byte, active-low puts lower byte of stored counter B on the Y bus.
$\overline{\text{GBU}}$	6	I	Gate B upper byte, active-low puts upper byte of stored counter B on the Y bus.
GND	10	—	Ground
RCLK	7	I	Register Clock, rising edge stores counters into an internal storage register
$\overline{\text{RCOA}}$	8	O	Ready case overflow A, active low when counter A is full count and ready to overflow on next clock A
V _{CC}	20	—	Power supply pin
Y0	19	O	Data output bit 0 (LSB)
Y1	18	O	Data output bit 1
Y2	17	O	Data output bit 2
Y3	16	O	Data output bit 3
Y4	15	O	Data output bit 4
Y5	14	O	Data output bit 5
Y6	13	O	Data output bit 6
Y7	12	O	Data output bit 7 (MSB)

6 Specifications

6.1 Absolute Maximum Ratings

over operating free-air temperature range (unless otherwise noted)⁽¹⁾

		MIN	MAX	UNIT
V _{CC}	Supply voltage	-0.5	7	V
V _I	Input voltage ⁽²⁾	-0.5	7	V
V _O	Voltage applied to any output in the high-impedance or power-off state ⁽²⁾	-0.5	7	V
V _O	Output voltage ⁽²⁾⁽³⁾	-0.5	V _{CC} + 0.5	V
I _{IK}	Input clamp current	V _I < 0	-20	mA
I _{OK}	Output clamp current	V _O < 0	-50	mA
I _O	Continuous output current	V _O = 0 to V _{CC}	±35	mA
	Continuous current through V _{CC} or GND		±70	mA
T _J	Junction Temperature		150	°C
T _{stg}	Storage temperature	-65	150	°C

(1) Stresses beyond those listed under *Absolute Maximum Ratings* may cause permanent damage to the device. These are stress ratings only, which do not imply functional operation of the device at these or any other conditions beyond those indicated under *Recommended Operating Conditions*. Exposure to absolute-maximum-rated conditions for extended periods may affect device reliability.

(2) The input and output voltage ratings may be exceeded if the input and output current ratings are observed.

(3) This value is limited to 5.5 V maximum.

6.2 ESD Ratings

		VALUE	UNIT
V _(ESD)	Electrostatic discharge	Human body model (HBM), per ANSI/ESDA/JEDEC JS-001, all pins ⁽¹⁾	±2000
		Charged device model (CDM), per JEDEC specification JESD22-C101, all pins ⁽²⁾	±1000

(1) JEDEC document JEP155 states that 500-V HBM allows safe manufacturing with a standard ESD control process.

(2) JEDEC document JEP157 states that 250-V CDM allows safe manufacturing with a standard ESD control process.

6.3 Recommended Operating Conditions⁽¹⁾

		V _{CC}	MIN	MAX	UNIT
V _{CC}	Supply voltage		2	5.5	V
V _{IH}	High-level input voltage	2 V	1.5		V
		3 V to 3.6 V	V _{CC} × 0.7		
		4.5 V to 5.5 V	V _{CC} × 0.7		
V _{IL}	Low-level input voltage	2 V		0.5	V
		3 V to 3.6 V		V _{CC} × 0.3	
		4.5 V to 5.5 V		V _{CC} × 0.3	
V _I	Input voltage		0	5.5	V
V _O	Output voltage	High or low state	0	V _{CC}	V
		3-state	0	5.5	
I _{OH}	High-level output current	2 V		-50	μA
		3 V to 3.6 V		-6	
		4.5 V to 5.5 V		-12	
I _{OL}	Low-level output current	2 V		50	μA
		3 V to 3.6 V		6	
		4.5 V to 5.5 V		12	
Δt/Δv	Input transition rise and fall rate	3 V to 3.6 V		100	ns/V
		4.5 V to 5.5 V		20	
T _A	Operating free-air temperature		-40	85	°C

(1) All unused inputs of the device must be held at V_{CC} or GND to ensure proper device operation. Refer to the TI application report, *Implications of Slow or Floating CMOS Inputs*, [SCBA004](#).

6.4 Thermal Information

THERMAL METRIC ⁽¹⁾		SN74LV8154N	SN74LV8154PW	UNIT
		N (PDIP)	PW (TSSOP)	
		20 PINS	20 PINS	
R _{θJA}	Junction-to-ambient thermal resistance	54.9	100.2	°C/W
R _{θJC(top)}	Junction-to-case (top) thermal resistance	46.5	30.9	°C/W
R _{θJB}	Junction-to-board thermal resistance	35.9	47.1	°C/W
ψ _{JT}	Junction-to-top characterization parameter	23.5	1.5	°C/W
ψ _{JB}	Junction-to-board characterization parameter	35.7	46.6	°C/W

(1) For more information about traditional and new thermal metrics, see the *Semiconductor and IC Package Thermal Metrics* application report (SPRA953).

6.5 Electrical Characteristics

over recommended operating free-air temperature range (unless otherwise noted)

PARAMETER		TEST CONDITIONS	V _{CC}	MIN	TYP	MAX	UNIT
V _{OH}	Output high voltage	I _{OH} = -50 μA	2 V	1.9			V
		I _{OH} = -6 mA	3 V	2.48			
		I _{OH} = -12 mA	4.5 V	3.8			
V _{OL}	Output low voltage	I _{OL} = 50 μA	2 V			0.1	V
		I _{OL} = 6 mA	3 V			0.44	
		I _{OL} = 12 mA	4.5 V			0.55	
I _I	Input current	V _I = 5.5 V or GND	0 to 5.5 V			±1	μA
I _{OZ}	Output off current	V _O = V _{CC} or GND	5.5 V			±5	μA
I _{CC}	Supply current	V _I = V _{CC} or GND, I _O = 0	5.5 V			20	μA
I _{off}	Off current	V _I or V _O = 0 to 5.5 V	0			5	μA
C _I	Input capacitance	V _I = V _{CC} or GND	5 V		3		pF
C _O	Output capacitance	V _O = V _{CC} or GND	5 V		5		pF
C _{pd}	Power dissipation capacitance	C _L = No load, CCLK = 10 MHz, RCLK = 1 MHz	5 V		56		pF

6.6 Timing Requirements

over recommended operating free-air temperature range, V_{CC} = 5 V ± 0.5 V (unless otherwise noted) (see Figure 3)

			MIN	UNIT
t _w	Pulse duration	CLKA, CLKB, RCLK high or low	10	ns
		$\overline{\text{CCLR}}$ low	20	
t _{su}	Set-up time	$\overline{\text{CLKBEN}}$ low before CLKB↑	10	ns
		$\overline{\text{CCLR}}$ high (inactive) before CLKA↑ or CLKB↑	10	
		CLKA↑ or CLKB↑ before RCLK↑	10	
		RCLK↑ before $\overline{\text{GAL}}$ or $\overline{\text{GAU}}$ or $\overline{\text{GBL}}$ or $\overline{\text{GBU}}$ low	10	
		$\overline{\text{GAL}}$ or $\overline{\text{GAU}}$ or $\overline{\text{GBL}}$ or $\overline{\text{GBU}}$ high (inactive) before RCLK↑	10	
t _h	Hold time	$\overline{\text{CLKBEN}}$ low after CLKB↑	0	ns
		CLKA or CLKB after RCLK	0	
t _z ⁽¹⁾	Z-period	$\overline{\text{GAL}}$, $\overline{\text{GAU}}$, $\overline{\text{GBL}}$, $\overline{\text{GBU}}$ all high before one of them switches low	200	ns

(1) t_z condition: C_L = 50 pF, R_L = 1 kΩ

6.7 Switching Characteristics - $V_{CC} = 3.3 V \pm 0.3 V$

 over recommended operating free-air temperature range, $V_{CC} = 3.3 V \pm 0.3 V$ (unless otherwise noted) (see [Figure 3](#))

PARAMETER	FROM (INPUT)	TO (OUTPUT)	LOAD CAPACITANCE	MIN	TYP	MAX	UNIT	
f_{MAX}			$C_L = 15 \text{ pF}$	40			MHz	
			$C_L = 50 \text{ pF}$	25				
t_{pd}	RCLK	Y	$C_L = 15 \text{ pF}$	1	22	38	ns	
	CLKA	\overline{RCOA}		1	26	44		
t_{PLH}	\overline{CCLR}	\overline{RCOA}		1	18	32	ns	
t_{en}	$\overline{GAL}, \overline{GAU}, \overline{GBL}, \overline{GBU}$	Y		1	27	46	ns	
t_{dis}	$\overline{GAL}, \overline{GAU}, \overline{GBL}, \overline{GBU}$	Y		1	12	21	ns	
t_{pd}	RCLK	Y		$C_L = 50 \text{ pF}$	1	25	42	ns
	CLKA	\overline{RCOA}			1	28	46	
t_{PLH}	\overline{CCLR}	\overline{RCOA}			1	20	35	ns
t_{en}	$\overline{GAL}, \overline{GAU}, \overline{GBL}, \overline{GBU}$	Y	1		30	50	ns	
t_{dis}	$\overline{GAL}, \overline{GAU}, \overline{GBL}, \overline{GBU}$	Y	1		14	24	ns	

6.8 Switching Characteristics $V_{CC} = 5 V \pm 0.5 V$

 over recommended operating free-air temperature range, $V_{CC} = 5 V \pm 0.5 V$ (unless otherwise noted) (see [Figure 3](#))

PARAMETER	FROM (INPUT)	TO (OUTPUT)	LOAD CAPACITANCE	MIN	TYP	MAX	UNIT	
f_{MAX}			$C_L = 15 \text{ pF}$	40			MHz	
			$C_L = 50 \text{ pF}$	25				
t_{pd}	RCLK	Y	$C_L = 15 \text{ pF}$	1	14	25	ns	
	CLKA	\overline{RCOA}		1	16	27		
t_{PLH}	\overline{CCLR}	\overline{RCOA}		1	12	20	ns	
t_{en}	$\overline{GAL}, \overline{GAU}, \overline{GBL}, \overline{GBU}$	Y		1	16	28	ns	
t_{dis}	$\overline{GAL}, \overline{GAU}, \overline{GBL}, \overline{GBU}$	Y		1	8	15	ns	
t_{pd}	RCLK	Y		$C_L = 50 \text{ pF}$	1	16	27	ns
	CLKA	\overline{RCOA}			1	17	28	
t_{PLH}	\overline{CCLR}	\overline{RCOA}			1	13	21	ns
t_{en}	$\overline{GAL}, \overline{GAU}, \overline{GBL}, \overline{GBU}$	Y	1		18	30	ns	
t_{dis}	$\overline{GAL}, \overline{GAU}, \overline{GBL}, \overline{GBU}$	Y	1		9	16	ns	

6.9 Noise Characteristics

 $V_{CC} = 5 V, C_L = 50 \text{ pF}$

PARAMETER	MIN	TYP	MAX	UNIT
$V_{OL(P)}$ Quiet output, maximum dynamic V_{OL}		0.7		V
$V_{OL(V)}$ Quiet output, minimum dynamic V_{OL}		-0.75		V
$V_{OH(V)}$ Quiet output, minimum dynamic V_{OH}		4.4		V

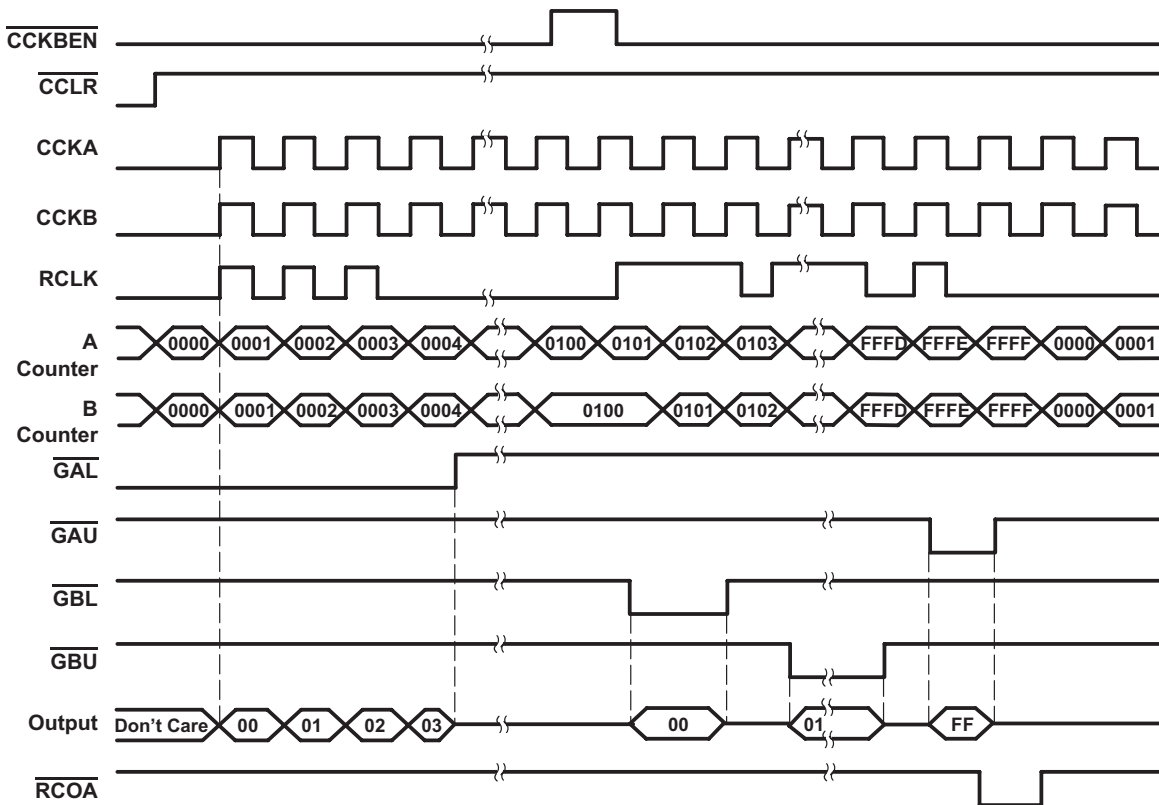

Figure 1. Timing Diagram

6.10 Typical Characteristics

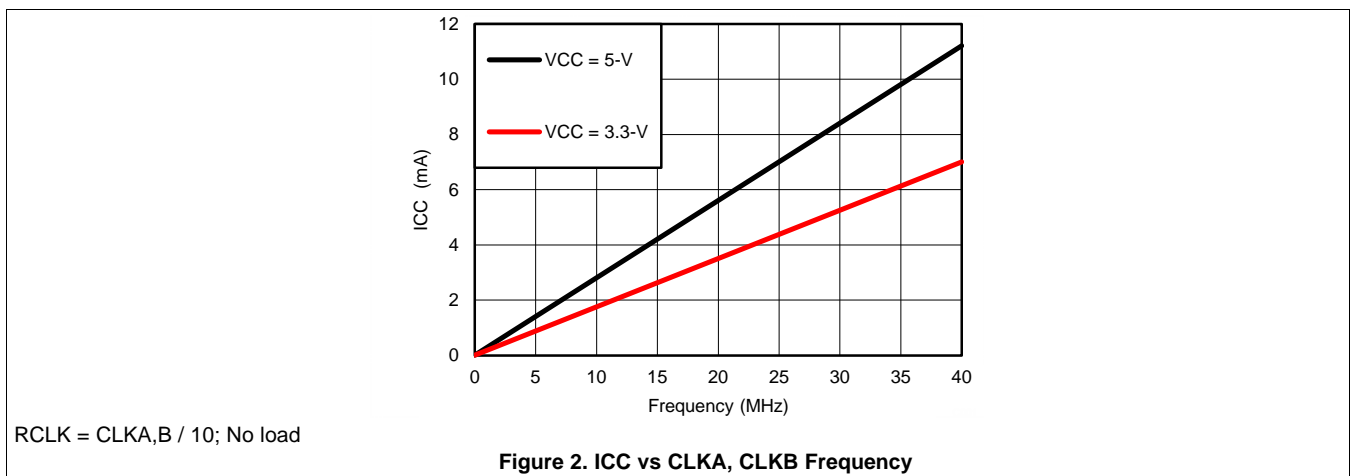
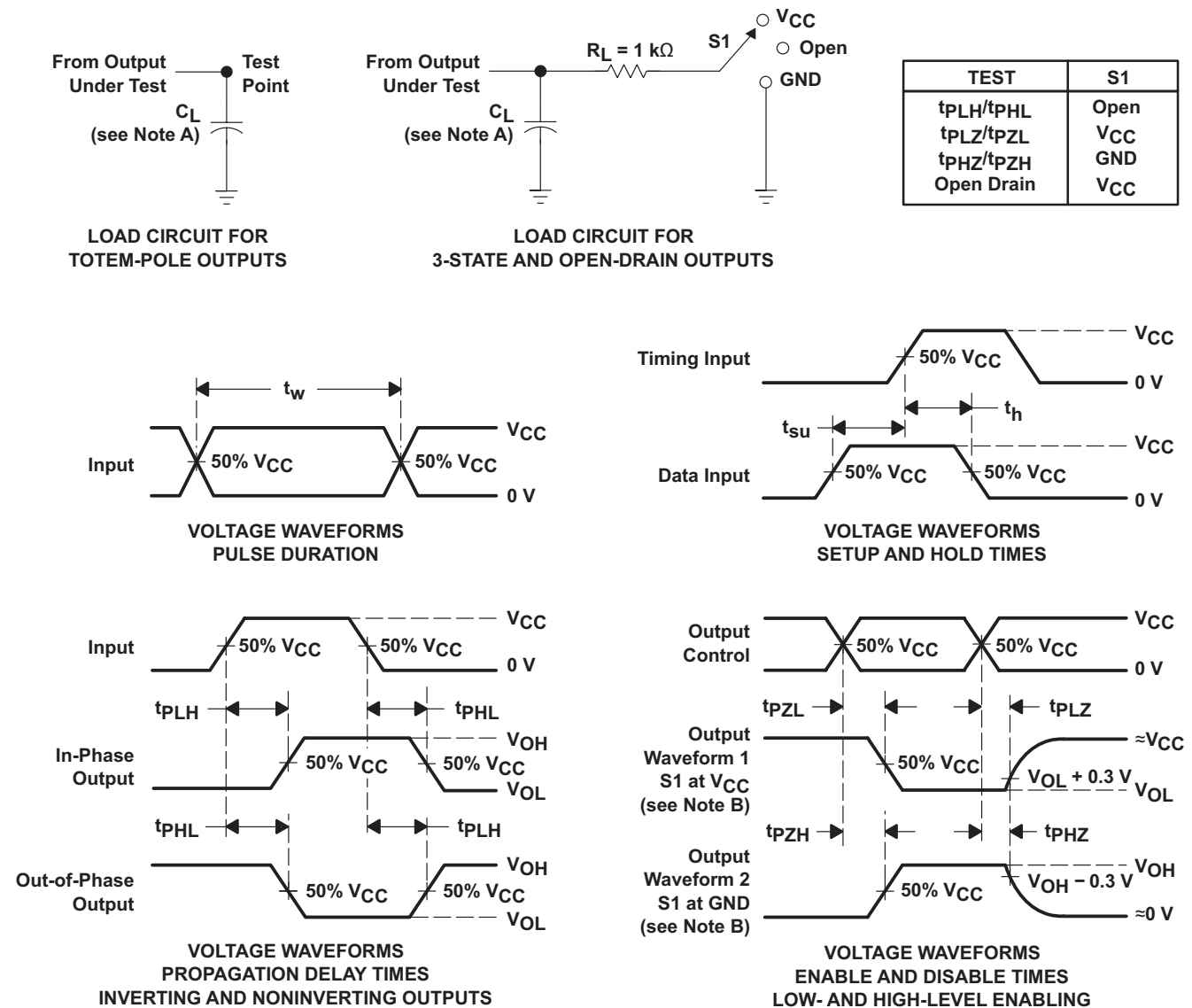

Figure 2. ICC vs CLKA, CLKB Frequency

7 Parameter Measurement Information



- NOTES:
- A. C_L includes probe and jig capacitance.
 - B. Waveform 1 is for an output with internal conditions such that the output is low, except when disabled by the output control. Waveform 2 is for an output with internal conditions such that the output is high, except when disabled by the output control.
 - C. All input pulses are supplied by generators having the following characteristics: $PRR \leq 1\text{ MHz}$, $Z_O = 50\ \Omega$, $t_r \leq 3\text{ ns}$, $t_f \leq 3\text{ ns}$.
 - D. The outputs are measured one at a time, with one input transition per measurement.
 - E. t_{PLZ} and t_{PHZ} are the same as t_{dis} .
 - F. t_{PZL} and t_{PZH} are the same as t_{en} .
 - G. t_{PHL} and t_{PLH} are the same as t_{pd} .
 - H. All parameters and waveforms are not applicable to all devices.

Figure 3. Load Circuit and Voltage Waveforms

8 Detailed Description

8.1 Overview

The SN74LV8154 device is a dual 16-bit binary counter with 3-state output registers, designed for 2-V to 5.5-V V_{CC} operation. The counters have dedicated clock inputs. The counters share a storage register clock and an asynchronous clear input. The 32-bit storage register can be mapped on the output bus 8-bit at a time. Four bus reads are needed to access the contents of both counters. The two counters can be chained by connecting \overline{CLKBEN} to \overline{RCOA} .

This 16-bit counter (A or B) feeds a 16-bit storage register, and each storage register is further divided into an upper byte and lower byte. The \overline{GAL} , \overline{GAU} , \overline{GBL} , and \overline{GBU} inputs are used to select the byte that needs to be output at Y_0 – Y_7 . \overline{CLKA} is the clock for A counter, and \overline{CLKB} is the clock for B counter. \overline{RCLK} is the clock for the A and B storage registers. All three clock signals are positive-edge triggered.

A 32-bit counter can be realized by connecting \overline{CLKA} and \overline{CLKB} together and by connecting \overline{RCOA} to \overline{CLKBEN} .

To ensure the high-impedance state during power up or power down, \overline{GAL} , \overline{GAU} , \overline{GBL} , and \overline{GBU} should be tied to V_{CC} through a pullup resistor; the minimum value of the resistor is determined by the current-sinking capability of the driver.

This device is fully specified for partial-power-down applications using I_{off} . The I_{off} circuitry disables the outputs, preventing damaging current backflow through the device when it is powered down.

8.2 Functional Block Diagram

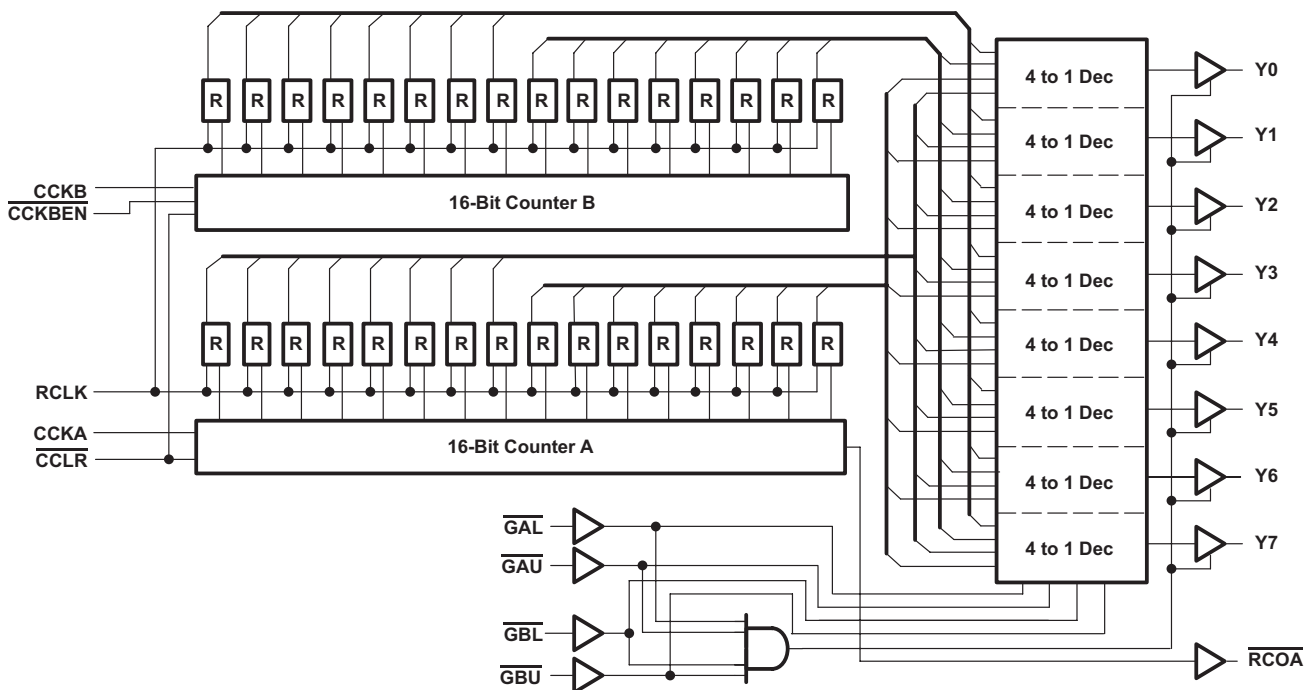

8.3 Feature Description

Two 16-bit counters count up on each positive edge of the respective clock input. \overline{RCOA} is set low when counter A is full count. Counter B clock is gated by the \overline{CCKBEN} input. Connecting \overline{RCOA} to \overline{CCKBEN} together chains the counters to make one 32-bit counter.

Asynchronous \overline{CCLR} input resets both counter to zero.

One 32-bit storage register records the contents of both counters on the rising edge of \overline{RCLK} . The contents of the storage register are saved until the next rising edge of the \overline{RCLK} .

Mapped output bus can be set to high impedance or output 8-bits of the 32-bit storage register.

8.4 Device Functional Modes

Table 1 lists the functional modes of the SN74LV8154.

Table 1. Function Table

INPUTS				OUTPUT Y _n
$\overline{\text{GAL}}$	$\overline{\text{GAU}}$	$\overline{\text{GBL}}$	$\overline{\text{GBU}}$	
L	H	H	H	Lower byte in A storage register
H	L	H	H	Upper byte in A storage register
H	H	L	H	Lower byte in B storage register
H	H	H	L	Upper byte in B storage register
H	H	H	H	Z

9 Application and Implementation

NOTE

Information in the following applications sections is not part of the TI component specification, and TI does not warrant its accuracy or completeness. TI's customers are responsible for determining suitability of components for their purposes. Customers should validate and test their design implementation to confirm system functionality.

9.1 Application Information

The SN74LV8154 can count any two events up to a count of 65,535 per storage register read. It can also count one event up to a count of 4,294,967,295 per storage register read.

9.2 Typical Application

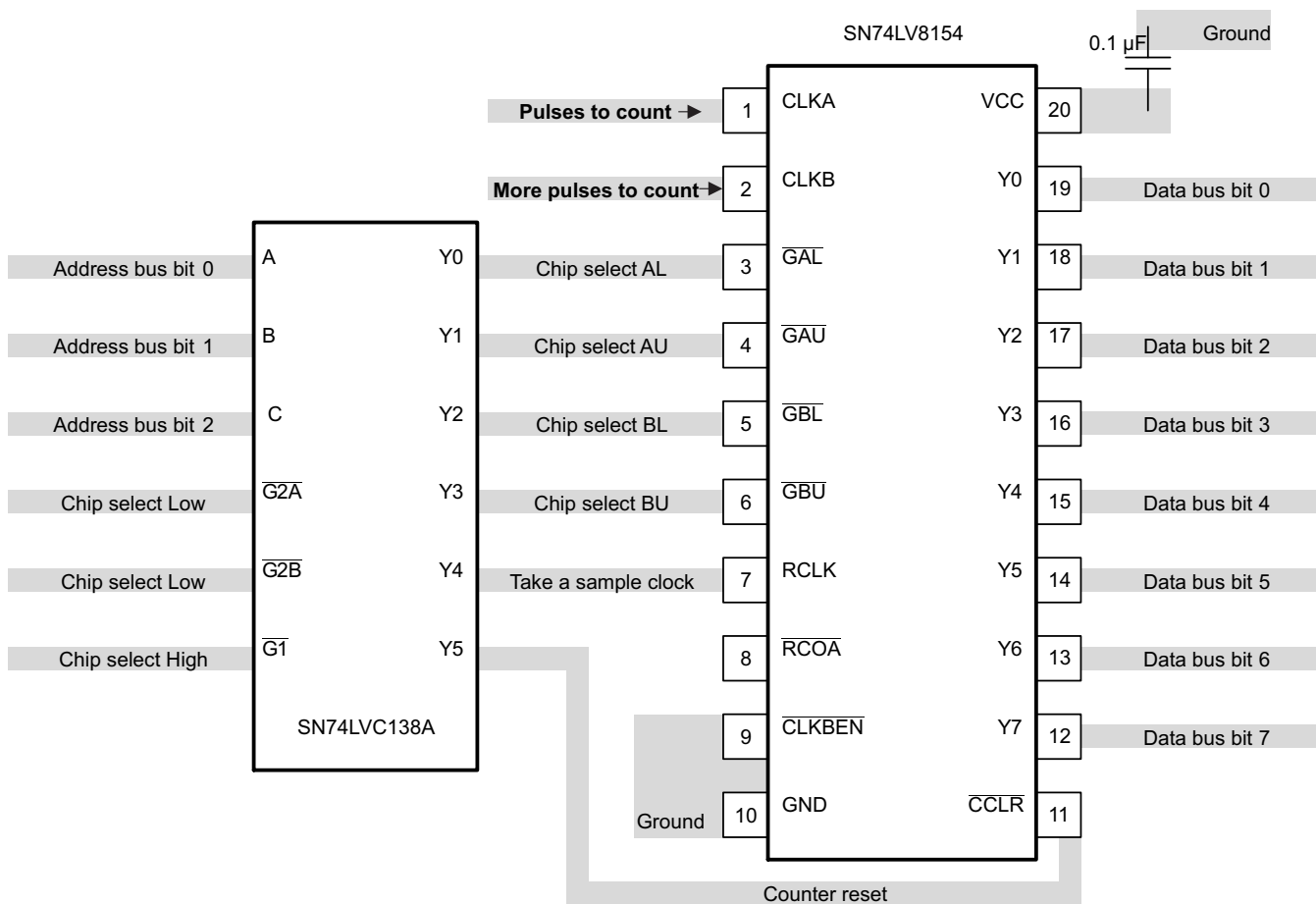

Dual Counter With Address Mapping

9.2.1 Design Requirements

- V_{CC} must be acceptable for both SN74LV8154 and SN74LVC138A.
- \overline{CCLR} low time must be greater than 20 ns.
- 8 bytes of unique address space are needed.
- CLK_A and CLK_B inputs must have input transition rate specified in *Recommended Operating Conditions*.
- RCLK and \overline{CCLR} inputs must be free of glitches to prevent accidental register saves or counter clears.

Typical Application (continued)

9.2.2 Detailed Design Procedure

- Connect Y0 through Y7 to the data bus.
- Connect A, B, and C to lower address bus lines.
- Connect $\overline{G2A}$, $\overline{G2B}$, and G1 to decoded addresses to provide 8 or more unique memory locations.
- Connect two pulse sources to CLKA and CLKB inputs. If sources have noise or slow edges then pass the signal through a Schmitt trigger buffer first.
- If only one counter is needed, connect the single pulse source to both CLKA and CLKB.
- Also connect CLKBEN to RCOA instead of ground.

Table 2. Function Table

INPUTS ⁽¹⁾						OUTPUT ⁽¹⁾	RESULT
G1	$\overline{G2A}$	$\overline{G2B}$	C	B	A	Yn	
L	X	X	X	X	X	Z	No action
X	H	X	X	X	X	Z	No action
X	X	H	X	X	X	Z	No action
H	L	L	L	L	L	A lower byte	Read lower byte of counter A storage register
H	L	L	L	L	H	A upper byte	Read upper byte of counter A storage register
H	L	L	L	H	L	B lower byte	Read lower byte of counter B storage register
H	L	L	L	H	H	B upper byte	Read upper byte of counter B storage register
H	L	L	H	L	L	Z	Save counters into storage register after changing any input
H	L	L	H	L	H	Z	Reset both counters to zero
H	L	L	H	H	L	Z	No action
H	L	L	H	H	H	Z	No action

(1) L = low, H = high, X = don't care, Z = high Impedance.

9.2.3 Application Curve

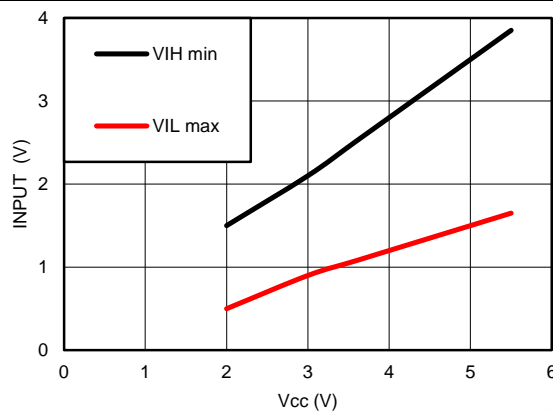

Figure 4. Input Voltage Range vs \overline{VCC}

10 Power Supply Recommendations

The power supply can be any voltage between the minimum and maximum supply voltage rating located in [Recommended Operating Conditions](#) table.

Each V_{CC} terminal should have a good bypass capacitor to prevent power disturbance. For devices with a single supply, a 0.1- μF capacitor is recommended. If there are multiple V_{CC} terminals then 0.01- μF or 0.022- μF capacitors are recommended for each power terminal. It is ok to parallel multiple bypass capacitors to reject different frequencies of noise. Multiple bypass capacitors may be paralleled to reject different frequencies of noise. The bypass capacitor should be installed as close to the power terminal as possible for the best results.

11 Layout

11.1 Layout Guidelines

When using multiple bit logic devices, inputs should not float. In many cases, functions or parts of functions of digital logic devices are unused. Some examples are when only two inputs of a triple-input AND gate are used, or when only 3 of the 4-buffer gates are used. Such input pins should not be left unconnected because the undefined voltages at the outside connections result in undefined operational states.

Specified in [Figure 5](#) are rules that must be observed under all circumstances. All unused inputs of digital logic devices must be connected to a high or low bias to prevent them from floating. The logic level that should be applied to any particular unused input depends on the function of the device. Generally they will be tied to GND or V_{CC} , whichever makes more sense or is more convenient.

11.2 Layout Example

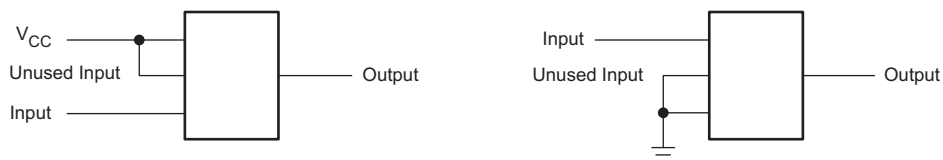

Figure 5. Layout Diagram

12 Device and Documentation Support

12.1 Documentation Support

12.1.1 Related Documentation

For related documentation, see the following:

Implications of Slow or Floating CMOS Inputs, [SCBA004](#)

12.2 Community Resources

The following links connect to TI community resources. Linked contents are provided "AS IS" by the respective contributors. They do not constitute TI specifications and do not necessarily reflect TI's views; see TI's [Terms of Use](#).

TI E2E™ Online Community *TI's Engineer-to-Engineer (E2E) Community*. Created to foster collaboration among engineers. At [e2e.ti.com](#), you can ask questions, share knowledge, explore ideas and help solve problems with fellow engineers.

Design Support *TI's Design Support* Quickly find helpful E2E forums along with design support tools and contact information for technical support.

12.3 Trademarks

E2E is a trademark of Texas Instruments.
All other trademarks are the property of their respective owners.

12.4 Electrostatic Discharge Caution



These devices have limited built-in ESD protection. The leads should be shorted together or the device placed in conductive foam during storage or handling to prevent electrostatic damage to the MOS gates.

12.5 Glossary

[SLYZ022](#) — *TI Glossary*.

This glossary lists and explains terms, acronyms, and definitions.

13 Mechanical, Packaging, and Orderable Information

The following pages include mechanical, packaging, and orderable information. This information is the most current data available for the designated devices. This data is subject to change without notice and revision of this document. For browser-based versions of this data sheet, refer to the left-hand navigation.

PACKAGING INFORMATION

Orderable Device	Status (1)	Package Type	Package Drawing	Pins	Package Qty	Eco Plan (2)	Lead/Ball Finish (6)	MSL Peak Temp (3)	Op Temp (°C)	Device Marking (4/5)	Samples
SN74LV8154N	ACTIVE	PDIP	N	20	20	Pb-Free (RoHS)	CU NIPDAU	N / A for Pkg Type	-40 to 85	SN74LV8154N	Samples
SN74LV8154NE4	ACTIVE	PDIP	N	20	20	Pb-Free (RoHS)	CU NIPDAU	N / A for Pkg Type	-40 to 85	SN74LV8154N	Samples
SN74LV8154PW	ACTIVE	TSSOP	PW	20	70	Green (RoHS & no Sb/Br)	CU NIPDAU	Level-1-260C-UNLIM	-40 to 85	LV8154	Samples
SN74LV8154PWG4	ACTIVE	TSSOP	PW	20	70	Green (RoHS & no Sb/Br)	CU NIPDAU	Level-1-260C-UNLIM	-40 to 85	LV8154	Samples
SN74LV8154PWR	ACTIVE	TSSOP	PW	20	2000	Green (RoHS & no Sb/Br)	CU NIPDAU	Level-1-260C-UNLIM	-40 to 85	LV8154	Samples

(1) The marketing status values are defined as follows:

ACTIVE: Product device recommended for new designs.

LIFEBUY: TI has announced that the device will be discontinued, and a lifetime-buy period is in effect.

NRND: Not recommended for new designs. Device is in production to support existing customers, but TI does not recommend using this part in a new design.

PREVIEW: Device has been announced but is not in production. Samples may or may not be available.

OBSOLETE: TI has discontinued the production of the device.

(2) Eco Plan - The planned eco-friendly classification: Pb-Free (RoHS), Pb-Free (RoHS Exempt), or Green (RoHS & no Sb/Br) - please check <http://www.ti.com/productcontent> for the latest availability information and additional product content details.

TBD: The Pb-Free/Green conversion plan has not been defined.

Pb-Free (RoHS): TI's terms "Lead-Free" or "Pb-Free" mean semiconductor products that are compatible with the current RoHS requirements for all 6 substances, including the requirement that lead not exceed 0.1% by weight in homogeneous materials. Where designed to be soldered at high temperatures, TI Pb-Free products are suitable for use in specified lead-free processes.

Pb-Free (RoHS Exempt): This component has a RoHS exemption for either 1) lead-based flip-chip solder bumps used between the die and package, or 2) lead-based die adhesive used between the die and leadframe. The component is otherwise considered Pb-Free (RoHS compatible) as defined above.

Green (RoHS & no Sb/Br): TI defines "Green" to mean Pb-Free (RoHS compatible), and free of Bromine (Br) and Antimony (Sb) based flame retardants (Br or Sb do not exceed 0.1% by weight in homogeneous material)

(3) MSL, Peak Temp. - The Moisture Sensitivity Level rating according to the JEDEC industry standard classifications, and peak solder temperature.

(4) There may be additional marking, which relates to the logo, the lot trace code information, or the environmental category on the device.

(5) Multiple Device Markings will be inside parentheses. Only one Device Marking contained in parentheses and separated by a "~" will appear on a device. If a line is indented then it is a continuation of the previous line and the two combined represent the entire Device Marking for that device.

⁽⁶⁾ Lead/Ball Finish - Orderable Devices may have multiple material finish options. Finish options are separated by a vertical ruled line. Lead/Ball Finish values may wrap to two lines if the finish value exceeds the maximum column width.

Important Information and Disclaimer:The information provided on this page represents TI's knowledge and belief as of the date that it is provided. TI bases its knowledge and belief on information provided by third parties, and makes no representation or warranty as to the accuracy of such information. Efforts are underway to better integrate information from third parties. TI has taken and continues to take reasonable steps to provide representative and accurate information but may not have conducted destructive testing or chemical analysis on incoming materials and chemicals. TI and TI suppliers consider certain information to be proprietary, and thus CAS numbers and other limited information may not be available for release.

In no event shall TI's liability arising out of such information exceed the total purchase price of the TI part(s) at issue in this document sold by TI to Customer on an annual basis.

OTHER QUALIFIED VERSIONS OF SN74LV8154 :

- Enhanced Product: [SN74LV8154-EP](#)

NOTE: Qualified Version Definitions:

- Enhanced Product - Supports Defense, Aerospace and Medical Applications

N (R-PDIP-T**)

PLASTIC DUAL-IN-LINE PACKAGE

16 PINS SHOWN



4040049/E 12/2002

- NOTES:
- A. All linear dimensions are in inches (millimeters).
 - B. This drawing is subject to change without notice.
 - (C) Falls within JEDEC MS-001, except 18 and 20 pin minimum body length (Dim A).
 - (D) The 20 pin end lead shoulder width is a vendor option, either half or full width.

PW (R-PDSO-G20)

PLASTIC SMALL OUTLINE



4040064-5/G 02/11

- NOTES:
- A. All linear dimensions are in millimeters. Dimensioning and tolerancing per ASME Y14.5M-1994.
 - B. This drawing is subject to change without notice.
 - C. Body length does not include mold flash, protrusions, or gate burrs. Mold flash, protrusions, or gate burrs shall not exceed 0,15 each side.
 - D. Body width does not include interlead flash. Interlead flash shall not exceed 0,25 each side.
 - E. Falls within JEDEC MO-153

PW (R-PDSO-G20)

PLASTIC SMALL OUTLINE



- NOTES:
- A. All linear dimensions are in millimeters.
 - B. This drawing is subject to change without notice.
 - C. Publication IPC-7351 is recommended for alternate design.
 - D. Laser cutting apertures with trapezoidal walls and also rounding corners will offer better paste release. Customers should contact their board assembly site for stencil design recommendations. Refer to IPC-7525 for other stencil recommendations.
 - E. Customers should contact their board fabrication site for solder mask tolerances between and around signal pads.

IMPORTANT NOTICE

Texas Instruments Incorporated and its subsidiaries (TI) reserve the right to make corrections, enhancements, improvements and other changes to its semiconductor products and services per JESD46, latest issue, and to discontinue any product or service per JESD48, latest issue. Buyers should obtain the latest relevant information before placing orders and should verify that such information is current and complete. All semiconductor products (also referred to herein as "components") are sold subject to TI's terms and conditions of sale supplied at the time of order acknowledgment.

TI warrants performance of its components to the specifications applicable at the time of sale, in accordance with the warranty in TI's terms and conditions of sale of semiconductor products. Testing and other quality control techniques are used to the extent TI deems necessary to support this warranty. Except where mandated by applicable law, testing of all parameters of each component is not necessarily performed.

TI assumes no liability for applications assistance or the design of Buyers' products. Buyers are responsible for their products and applications using TI components. To minimize the risks associated with Buyers' products and applications, Buyers should provide adequate design and operating safeguards.

TI does not warrant or represent that any license, either express or implied, is granted under any patent right, copyright, mask work right, or other intellectual property right relating to any combination, machine, or process in which TI components or services are used. Information published by TI regarding third-party products or services does not constitute a license to use such products or services or a warranty or endorsement thereof. Use of such information may require a license from a third party under the patents or other intellectual property of the third party, or a license from TI under the patents or other intellectual property of TI.

Reproduction of significant portions of TI information in TI data books or data sheets is permissible only if reproduction is without alteration and is accompanied by all associated warranties, conditions, limitations, and notices. TI is not responsible or liable for such altered documentation. Information of third parties may be subject to additional restrictions.

Resale of TI components or services with statements different from or beyond the parameters stated by TI for that component or service voids all express and any implied warranties for the associated TI component or service and is an unfair and deceptive business practice. TI is not responsible or liable for any such statements.

Buyer acknowledges and agrees that it is solely responsible for compliance with all legal, regulatory and safety-related requirements concerning its products, and any use of TI components in its applications, notwithstanding any applications-related information or support that may be provided by TI. Buyer represents and agrees that it has all the necessary expertise to create and implement safeguards which anticipate dangerous consequences of failures, monitor failures and their consequences, lessen the likelihood of failures that might cause harm and take appropriate remedial actions. Buyer will fully indemnify TI and its representatives against any damages arising out of the use of any TI components in safety-critical applications.

In some cases, TI components may be promoted specifically to facilitate safety-related applications. With such components, TI's goal is to help enable customers to design and create their own end-product solutions that meet applicable functional safety standards and requirements. Nonetheless, such components are subject to these terms.

No TI components are authorized for use in FDA Class III (or similar life-critical medical equipment) unless authorized officers of the parties have executed a special agreement specifically governing such use.

Only those TI components which TI has specifically designated as military grade or "enhanced plastic" are designed and intended for use in military/aerospace applications or environments. Buyer acknowledges and agrees that any military or aerospace use of TI components which have **not** been so designated is solely at the Buyer's risk, and that Buyer is solely responsible for compliance with all legal and regulatory requirements in connection with such use.

TI has specifically designated certain components as meeting ISO/TS16949 requirements, mainly for automotive use. In any case of use of non-designated products, TI will not be responsible for any failure to meet ISO/TS16949.

Products

Audio	www.ti.com/audio
Amplifiers	amplifier.ti.com
Data Converters	dataconverter.ti.com
DLP® Products	www.dlp.com
DSP	dsp.ti.com
Clocks and Timers	www.ti.com/clocks
Interface	interface.ti.com
Logic	logic.ti.com
Power Mgmt	power.ti.com
Microcontrollers	microcontroller.ti.com
RFID	www.ti-rfid.com
OMAP Applications Processors	www.ti.com/omap
Wireless Connectivity	www.ti.com/wirelessconnectivity

Applications

Automotive and Transportation	www.ti.com/automotive
Communications and Telecom	www.ti.com/communications
Computers and Peripherals	www.ti.com/computers
Consumer Electronics	www.ti.com/consumer-apps
Energy and Lighting	www.ti.com/energy
Industrial	www.ti.com/industrial
Medical	www.ti.com/medical
Security	www.ti.com/security
Space, Avionics and Defense	www.ti.com/space-avionics-defense
Video and Imaging	www.ti.com/video

TI E2E Community

e2e.ti.com