

1 13/16" (46 mm) Three Turn Wirewound Bushing Mount



FEATURES

- Gangable up to 2 sections
- Large range of ohmic values: 15 Ω to 50 kΩ
- Extra taps available upon request
- Ideally suits for all industry applications

ELECTRICAL SPECIFICATIONS		
PARAMETER	MODEL 830	
Total Resistance Standard Range Tolerance: 200 Ω and Above Below 200 Ω	15 Ω to 50 kΩ STANDARD ± 3 % ± 5 %	SPECIAL to 150 kΩ SPECIAL ± 1 % ± 3 %
Linearity (Independent)	± 0.25 % standard	
15 Ω to 1 kΩ 1 kΩ to 5 kΩ 5 kΩ to 25 kΩ 25 kΩ and Above	± 0.15 % ± 0.10 % ± 0.075 % ± 0.05 %	
Noise	100 Ω ENR	
Electrical Rotation	1080° + 4° - 0°	
Power Rating	3.0 W at 40 °C derated to zero at 125 °C	
Insulation Resistance	1000 MΩ minimum 500 V _{DC}	
Dielectric Strength	1000 V _{RMS} , 60 Hz	
Absolute Minimum Resistance	Not to exceed linearity x total resistance or 1 Ω, whichever is greater	
End Voltage	0.5 % of total applied voltage maximum	
Phasing	CCW end points sect. 2 phased to sect 1 within 1°	
Taps (Extra)	Available as special standard tolerance ± 1°	

ORDERING INFORMATION/DESCRIPTION				
Model 830 can be ordered from this data sheet with a variety of alternate characteristics, as shown. For most rapid service on your order, please state:				
830	B	1	20K	BO10
MODEL	BUSHING MOUNT	NUMBER OF SECTIONS	RESISTANCE OF EACH SECTION	PACKAGING
		From 1 up to 2 sections (maximum)	Beginning with the section nearest the mounting end	Box of 10 pieces

SAP PART NUMBERING GUIDELINES				
830	B	1	203	B10
MODEL	STYLE	NUMBER OF SECTIONS	OHMIC VALUE OF SECTION N° 1	PACKAGING

Model 830



Vishay Spectrol

1 13/16" (46 mm) Three Turn Wirewound
Bushing Mount

DIMENSIONS in inches (millimeters)

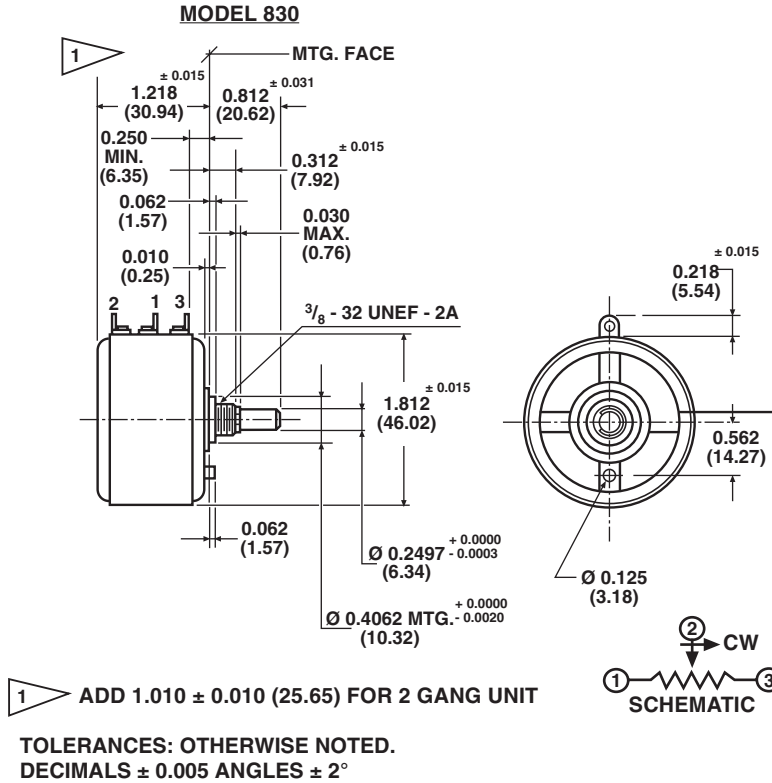

MECHANICAL SPECIFICATIONS		
PARAMETER		
Rotation	1080° + 4° - 0°	
Bearing Type	Sleeve bearing	
Torque (maximums): Starting Section 1 Section 2	STARTING 1.75 oz. - in (126.02 g - cm) 2.55 oz. - in (183.62 g - cm)	RUNNING 1.26 oz. - in (90.01 g - cm) 1.85 oz. - in (133.21 g - cm)
Runouts (Maximums) Shaft (TIR) Pilot Dia. (TIR) Lateral (TIR) Shaft End Play Shaft Radial Play	0.002" (0.05 cm) 0.002" (0.05 cm) 0.005" (0.13 cm) 0.002" min. 0.010" max. (0.05 - 0.25 cm) 0.003" max. (0.08 cm)	
Weight (maximums) Single Section Additional Section	3.0 oz. (85.05 g) 2.5 oz. (70.80 g)	
Stop Strength	750 oz. - in (static) (54.01 kg - cm)	
Ganging	2 sections maximum ears of clamp band between sections positioned 45°, ± 10° CCW from terminal center line	
Moment Inertia	5.5 g - cm ² maximum	



**1 13/16" (46 mm) Three Turn Wirewound
Bushing Mount**

MATERIAL SPECIFICATIONS	
Bushing	Aluminum, nickel plated
Housing and Front Lid	Molded glass filled thermoset plastic
Rear Lid	Molded glass filled nylon
Shaft	Stainless steel, non magnetic, non-passivated
Terminals	Brass, plated for solderability
Mounting Hardware Lockwasher: Panel Nut:	Internal tooth steel, nickel plated Brass, nickel plated

ENVIRONMENTAL SPECIFICATIONS	
Vibration	10 g thru 500 CPS
Shock	50 g
Rotational Life	500 000 shaft revolution
Load Life	900 h
Temperature Range	- 55 °C to + 125 °C
Salt Spray	48 h

MARKING	
Unit Identification	Units will be marked with Spectrol name and model no, resistance and resistance tolerance, linearity, terminal identification, and date code

POWER RATING CHART

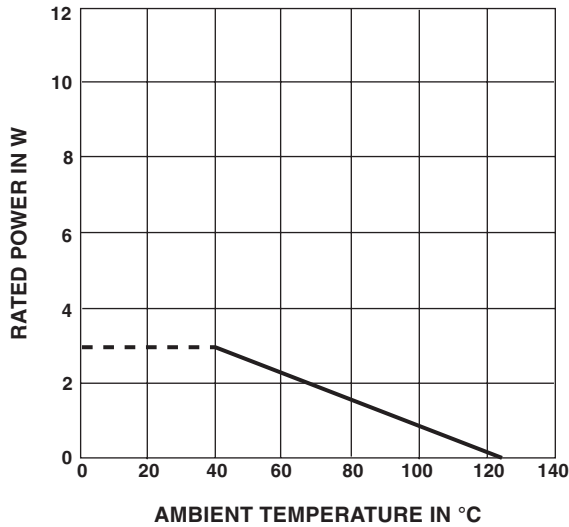

RESISTANCE ELEMENT DATA					
STANDARD RESISTANCE VALUES (W)	RESOLUTION (%)	OHMS PER TURN	MAXIMUM CURRENT AT 70 °C AMBIENT (mA)	MAXIMUM VOLTAGE ACROSS COIL (V)	WIRE TEMP. COEF. (ppm/°C)
20	0.094	0.019	387	8	800
50	0.074	0.037	245	12	800
100	0.071	0.071	173	17	180
200	0.072	0.145	122	25	20
500	0.064	0.320	77	39	20
1K	0.050	0.500	55	55	20
2K	0.047	0.948	39	77	20
5K	0.035	1.73	24	125	20
10K	0.029	2.92	17	176	20
20K	0.024	4.80	12	250	20
50K	0.017	8.31	8	375	20
100K	0.015	14.5	5	600	20
150K	0.013	20.0	4	750	20



Disclaimer

ALL PRODUCT, PRODUCT SPECIFICATIONS AND DATA ARE SUBJECT TO CHANGE WITHOUT NOTICE TO IMPROVE RELIABILITY, FUNCTION OR DESIGN OR OTHERWISE.

Vishay Intertechnology, Inc., its affiliates, agents, and employees, and all persons acting on its or their behalf (collectively, "Vishay"), disclaim any and all liability for any errors, inaccuracies or incompleteness contained in any datasheet or in any other disclosure relating to any product.

Vishay makes no warranty, representation or guarantee regarding the suitability of the products for any particular purpose or the continuing production of any product. To the maximum extent permitted by applicable law, Vishay disclaims (i) any and all liability arising out of the application or use of any product, (ii) any and all liability, including without limitation special, consequential or incidental damages, and (iii) any and all implied warranties, including warranties of fitness for particular purpose, non-infringement and merchantability.

Statements regarding the suitability of products for certain types of applications are based on Vishay's knowledge of typical requirements that are often placed on Vishay products in generic applications. Such statements are not binding statements about the suitability of products for a particular application. It is the customer's responsibility to validate that a particular product with the properties described in the product specification is suitable for use in a particular application. Parameters provided in datasheets and/or specifications may vary in different applications and performance may vary over time. All operating parameters, including typical parameters, must be validated for each customer application by the customer's technical experts. Product specifications do not expand or otherwise modify Vishay's terms and conditions of purchase, including but not limited to the warranty expressed therein.

Except as expressly indicated in writing, Vishay products are not designed for use in medical, life-saving, or life-sustaining applications or for any other application in which the failure of the Vishay product could result in personal injury or death. Customers using or selling Vishay products not expressly indicated for use in such applications do so at their own risk and agree to fully indemnify and hold Vishay and its distributors harmless from and against any and all claims, liabilities, expenses and damages arising or resulting in connection with such use or sale, including attorneys fees, even if such claim alleges that Vishay or its distributor was negligent regarding the design or manufacture of the part. Please contact authorized Vishay personnel to obtain written terms and conditions regarding products designed for such applications.

No license, express or implied, by estoppel or otherwise, to any intellectual property rights is granted by this document or by any conduct of Vishay. Product names and markings noted herein may be trademarks of their respective owners.

Material Category Policy

Vishay Intertechnology, Inc. hereby certifies that all its products that are identified as RoHS-Compliant fulfill the definitions and restrictions defined under Directive 2011/65/EU of The European Parliament and of the Council of June 8, 2011 on the restriction of the use of certain hazardous substances in electrical and electronic equipment (EEE) - recast, unless otherwise specified as non-compliant.

Please note that some Vishay documentation may still make reference to RoHS Directive 2002/95/EC. We confirm that all the products identified as being compliant to Directive 2002/95/EC conform to Directive 2011/65/EU.