

### General Description

The 83905-01 is a low skew, 1-to-6 LVCMOS Fanout Buffer. The low impedance LVCMOS outputs are designed to drive 50Ω series or parallel terminated transmission lines. The effective fanout can be increased from 6 to 12 by utilizing the ability of the outputs to drive two series terminated lines.

The 83905-01 is characterized at full 1.8V, 1.5V, and 1.2V, mixed 1.8V/1.5V, 1.8V/1.2V and 1.5V/1.2V output operating supply mode. Guaranteed output skew characteristics along with the 1.2V output capabilities makes the 83905-01 ideal for high performance, single ended applications that also require a limited output voltage.

### Pin Assignments

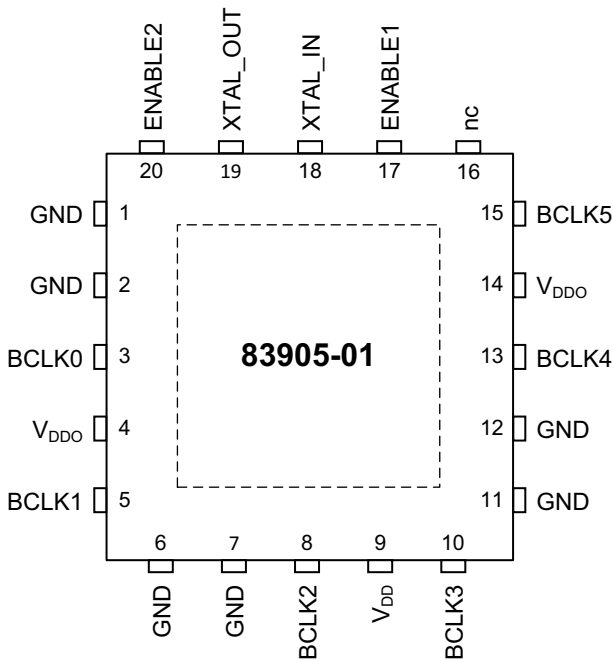

**20-pin, 4mm x 4mm VFQFN Package**

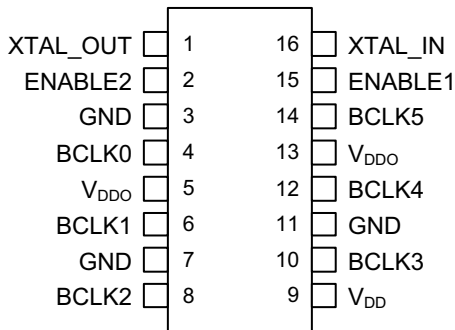

**83905-01**

**16-pin, 4.4mm x 5.0mm TSSOP Package**

### Features

- Six LVCMOS outputs
- Outputs able to drive 12 series terminated lines
- Crystal Oscillator Interface
- Crystal input frequency range: 10MHz to 40MHz
- Output skew: 95ps (maximum)
- RMS phase jitter @ 25MHz, (100Hz – 1MHz): 0.17ps (typical)

Offset	Noise Power
100Hz.....	-115 dBc/Hz
1kHz.....	-138 dBc/Hz
10kHz.....	-154 dBc/Hz
100kHz.....	-160 dBc/Hz

- Synchronous output enables
- Power supply modes: Full 1.8V, 1.5V, 1.2V  
Mixed 1.8V core/1.5V output operating supply  
Mixed 1.8V core/1.2V output operating supply  
Mixed 1.5V core/1.2V output operating supply
- 0°C to 70°C ambient operating temperature
- Available in lead-free (RoHS 6) package

### Block Diagram

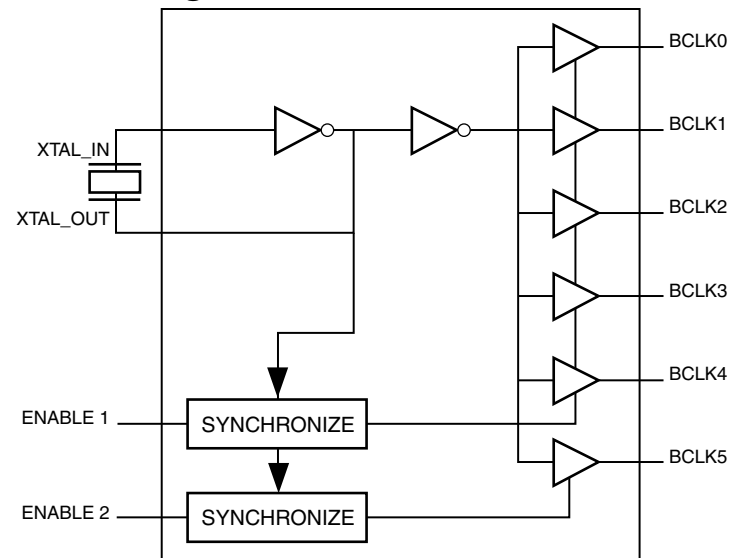

## Pin Descriptions and Characteristics

**Table 1. Pin Descriptions**

Name	Type	Description
XTAL_OUT	Output	Crystal oscillator interface.
XTAL_IN	Input	Crystal oscillator interface.
ENABLE1, ENABLE2	Input	Clock enable. LVCMOS/LVTTL interface levels. See Table 3.
BCLK0, BCLK1, BCLK2, BCLK3, BCLK4, BCLK5	Output	Clock outputs. LVCMOS interface levels.
GND	Power	Power supply ground.
V <sub>DD</sub>	Power	Power supply pin.
V <sub>DDO</sub>	Power	Output supply pin.
nc	Unused	No connect.

**Table 2. Pin Characteristics**

Symbol	Parameter	Test Conditions	Minimum	Typical	Maximum	Units
C <sub>IN</sub>	Input Capacitance	ENABLE[2:1]		4		pF
C <sub>PD</sub>	Power Dissipation Capacitance (per output)	V <sub>DDO</sub> = 2.0V		12		pF
		V <sub>DDO</sub> = 1.6V		12		pF
		V <sub>DDO</sub> = 1.26V		12		pF
R <sub>OUT</sub>	Output Impedance	V <sub>DDO</sub> = 1.8V ± 0.2V		17		Ω
		V <sub>DDO</sub> = 1.5V ± 0.1V		18		Ω
		V <sub>DDO</sub> = 1.2V ± 5%		24		Ω

## Function Table

**Table 3. Clock Enable Function Table**

Control Inputs		Outputs	
ENABLE 1	ENABLE2	BCLK[0:4]	BCLK5
0	0	LOW	LOW
0	1	LOW	Toggling
1	0	Toggling	LOW
1	1	Toggling	Toggling

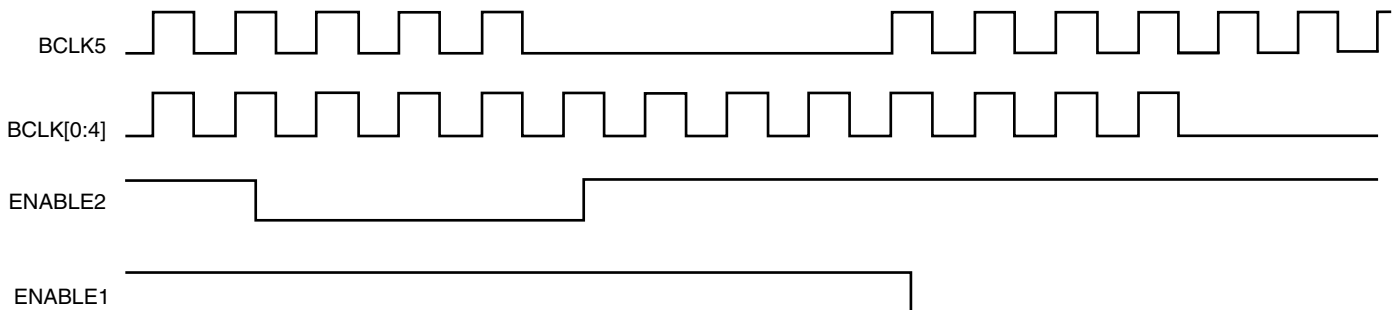
**Figure 1. Enable Timing Diagram**

## Absolute Maximum Ratings

NOTE: Stresses beyond those listed under *Absolute Maximum Ratings* may cause permanent damage to the device. These ratings are stress specifications only. Functional operation of product at these conditions or any conditions beyond those listed in the *DC Characteristics* or *AC Characteristics* is not implied. Exposure to absolute maximum rating conditions for extended periods may affect product reliability.

Item	Rating
Supply Voltage, $V_{DD}$	4.6V
Inputs, $V_I$	-0.5V to $V_{DD} + 0.5V$
Input, $V_I$ Crystal Oscillator Input	0V to $V_{DD}$
Outputs, $V_O$	-0.5V to $V_{DDO} + 0.5V$
Package Thermal Impedance, $T_J$	125°C
Storage Temperature, $T_{STG}$	-65°C to 150°C

## DC Electrical Characteristics

**Table 4A. Power Supply DC Characteristics,  $V_{DD} = V_{DDO} = 1.8V \pm 0.2V$ ,  $T_A = 0^\circ C$  to  $70^\circ C$**

Symbol	Parameter	Test Conditions	Minimum	Typical	Maximum	Units
$V_{DD}$	Power Supply Voltage		1.6	1.8	2.0	V
$V_{DDO}$	Output Supply Voltage		1.6	1.8	2.0	V
$I_{DD}$ ; NOTE 1	Power Supply Current	ENABLE [1:2] = 00		4	10	mA
$I_{DDO}$ ; NOTE 1	Output Supply Current	ENABLE [1:2] = 00			1	mA

NOTE 1: Measured with outputs unterminated, and XTAL\_IN and XTAL\_OUT floated.

**Table 4B. Power Supply DC Characteristics,  $V_{DD} = V_{DDO} = 1.5V \pm 0.1V$ ,  $T_A = 0^\circ C$  to  $70^\circ C$**

Symbol	Parameter	Test Conditions	Minimum	Typical	Maximum	Units
$V_{DD}$	Power Supply Voltage		1.4	1.5	1.6	V
$V_{DDO}$	Output Supply Voltage		1.4	1.5	1.6	V
$I_{DD}$ ; NOTE 1	Power Supply Current	ENABLE [1:2] = 00		3	7	mA
$I_{DDO}$ ; NOTE 1	Output Supply Current	ENABLE [1:2] = 00			1	mA

NOTE 1: Measured with outputs unterminated, and XTAL\_IN and XTAL\_OUT floated.

**Table 4C. Power Supply DC Characteristics,  $V_{DD} = V_{DDO} = 1.2V \pm 5\%$ ,  $T_A = 0^\circ C$  to  $70^\circ C$**

Symbol	Parameter	Test Conditions	Minimum	Typical	Maximum	Units
$V_{DD}$	Power Supply Voltage		1.14	1.2	1.26	V
$V_{DDO}$	Output Supply Voltage		1.14	1.2	1.26	V
$I_{DD}$ ; NOTE 1	Power Supply Current	ENABLE [1:2] = 00		2	6	mA
$I_{DDO}$ ; NOTE 1	Output Supply Current	ENABLE [1:2] = 00			1	mA

NOTE 1: Measured with outputs unterminated, and XTAL\_IN and XTAL\_OUT floated.

**Table 4D. Power Supply DC Characteristics,  $V_{DD} = 1.8V \pm 0.2V$ ,  $V_{DDO} = 1.5V \pm 0.1V$ ,  $T_A = 0^\circ C$  to  $70^\circ C$** 

Symbol	Parameter	Test Conditions	Minimum	Typical	Maximum	Units
$V_{DD}$	Power Supply Voltage		1.6	1.8	2.0	V
$V_{DDO}$	Output Supply Voltage		1.4	1.5	1.6	V
$I_{DD}$ ; NOTE 1	Power Supply Current	ENABLE [1:2] = 00		4	10	mA
$I_{DDO}$ ; NOTE 1	Output Supply Current	ENABLE [1:2] = 00			1	mA

NOTE 1: Measured with outputs unterminated, and XTAL\_IN and XTAL\_OUT floated.

**Table 4E. Power Supply DC Characteristics,  $V_{DD} = 1.8V \pm 0.2V$ ,  $V_{DDO} = 1.2V \pm 5\%$ ,  $T_A = 0^\circ C$  to  $70^\circ C$** 

Symbol	Parameter	Test Conditions	Minimum	Typical	Maximum	Units
$V_{DD}$	Power Supply Voltage		1.6	1.8	2.0	V
$V_{DDO}$	Output Supply Voltage		1.14	1.2	1.26	V
$I_{DD}$ ; NOTE 1	Power Supply Current	ENABLE [1:2] = 00		4	10	mA
$I_{DDO}$ ; NOTE 1	Output Supply Current	ENABLE [1:2] = 00			1	mA

NOTE 1: Measured with outputs unterminated, and XTAL\_IN and XTAL\_OUT floated.

**Table 4F. Power Supply DC Characteristics,  $V_{DD} = 1.5V \pm 0.1V$ ,  $V_{DDO} = 1.2V \pm 5\%$ ,  $T_A = 0^\circ C$  to  $70^\circ C$** 

Symbol	Parameter	Test Conditions	Minimum	Typical	Maximum	Units
$V_{DD}$	Power Supply Voltage		1.4	1.5	1.6	V
$V_{DDO}$	Output Supply Voltage		1.14	1.2	1.26	V
$I_{DD}$ ; NOTE 1	Power Supply Current	ENABLE [1:2] = 00		3	7	mA
$I_{DDO}$ ; NOTE 1	Output Supply Current	ENABLE [1:2] = 00			1	mA

NOTE 1: Measured with outputs unterminated, and XTAL\_IN and XTAL\_OUT floated.

**Table 4G. LVCMOS/LVTTL DC Characteristics,  $T_A = 0^\circ C$  to  $70^\circ C$** 

Symbol	Parameter	Test Conditions	Minimum	Typical	Maximum	Units
$V_{IH}$	Input High Voltage	$V_{DD} = 1.8V \pm 0.2V$	1.2		$V_{DD} + 0.3$	V
		$V_{DD} = 1.5V \pm 0.1V$	1.0		$V_{DD} + 0.3$	V
		$V_{DD} = 1.2V \pm 5\%$	0.8		$V_{DD} + 0.3$	V
$V_{IL}$	Input Low Voltage	$V_{DD} = 1.8V \pm 0.2V$	-0.3		0.4	V
		$V_{DD} = 1.5V \pm 0.1V$	-0.3		0.3	V
		$V_{DD} = 1.2V \pm 5\%$	-0.3		0.2	V
$V_{OH}$	Output High Voltage; NOTE 1	$V_{DDO} = 1.8V \pm 0.2V$	0.7			V
		$V_{DDO} = 1.5V \pm 0.1V$	0.7			V
		$V_{DDO} = 1.2V \pm 5\%$	0.7			V
$V_{OL}$	Output Low Voltage; NOTE 1	$V_{DDO} = 1.8V \pm 0.2V$			0.4	V
		$V_{DDO} = 1.5V \pm 0.1V$			0.4	V
		$V_{DDO} = 1.2V \pm 5\%$			0.4	V

NOTE 1: Outputs terminated with  $50\Omega$  to  $V_{DDO}/2$ . See Parameter Measurement Information, *Output Load Test Circuit diagrams*.

**Table 5. Crystal Characteristics**

Parameter	Test Conditions	Minimum	Typical	Maximum	Units
Mode of Oscillation		Fundamental			
Frequency		10		40	MHz
Equivalent Series Resistance (ESR)				50	$\Omega$
Shunt Capacitance				7	pF
Load Capacitance			12	18	pF

## AC Electrical Characteristics

**Table 6A. AC Characteristics,  $V_{DD} = V_{DDO} = 1.8V \pm 0.2V$ ,  $T_A = 0^\circ C$  to  $70^\circ C$** 

Symbol	Parameter	Test Conditions	Minimum	Typical	Maximum	Units
$f_{MAX}$	Output Frequency	Using External Crystal	10		40	MHz
		Using External Clock Source NOTE 1	1		100	MHz
$t_{sk(o)}$	Output Skew; NOTE 2, 3				90	ps
$t_{jit}$	RMS Phase Jitter (Random); NOTE 4	25MHz, Integration Range: 100Hz – 1MHz		0.17		ps
$t_R / t_F$	Output Rise/Fall Time	20% to 80%	300		600	ps
odc	Output Duty Cycle		42	50	58	%
$t_{EN}$	Output Enable Time; NOTE 5	ENABLE1			4	cycles
		ENABLE2			4	cycles
$t_{DIS}$	Output Disable Time; NOTE 5	ENABLE1			4	cycles
		ENABLE2			4	cycles

NOTE: Electrical parameters are guaranteed over the specified ambient operating temperature range, which is established when the device is mounted in a test socket with maintained transverse airflow greater than 500 lpm. The device will meet specifications after thermal equilibrium has been reached under these conditions.

All parameters measured at  $f \leq 40\text{MHz}$  using a crystal input unless noted otherwise. Outputs terminated with  $50\Omega$  to  $V_{DDO}/2$ .

NOTE 1: XTAL\_IN can be overdriven by an external source.

NOTE 2: Defined as skew between outputs at the same supply voltage and with equal load conditions. Measured at  $V_{DDO}/2$ .

NOTE 3: This parameter is defined in accordance with JEDEC Standard 65.

NOTE 4: See phase noise plot.

NOTE 5: These parameters are guaranteed by design. Not tested in production.

**Table 6B. AC Characteristics,  $V_{DD} = V_{DDO} = 1.5V \pm 0.1V$ ,  $T_A = 0^\circ C$  to  $70^\circ C$** 

Symbol	Parameter		Test Conditions	Minimum	Typical	Maximum	Units
$f_{MAX}$	Output Frequency	Using External Crystal		10		40	MHz
		Using External Clock Source; NOTE 1		1		100	MHz
$t_{sk(o)}$	Output Skew; NOTE 2, 3					90	ps
$t_{jit}$	RMS Phase Jitter (Random)		25MHz, Integration Range: 100Hz – 1MHz		0.3		ps
$t_R / t_F$	Output Rise/Fall Time		20% to 80%	300		650	ps
odc	Output Duty Cycle			44	50	56	%
$t_{EN}$	Output Enable Time; NOTE 4	ENABLE1				4	cycles
		ENABLE2				4	cycles
$t_{DIS}$	Output Disable Time; NOTE 4	ENABLE1				4	cycles
		ENABLE2				4	cycles

NOTE: Electrical parameters are guaranteed over the specified ambient operating temperature range, which is established when the device is mounted in a test socket with maintained transverse airflow greater than 500 lpm. The device will meet specifications after thermal equilibrium has been reached under these conditions.

All parameters measured at  $f \leq 40\text{MHz}$  using a crystal input unless noted otherwise. Outputs terminated with  $50\Omega$  to  $V_{DDO}/2$ .

NOTE 1: XTAL\_IN can be overdriven by an external source.

NOTE 2: Defined as skew between outputs at the same supply voltage and with equal load conditions. Measured at  $V_{DDO}/2$ .

NOTE 3: This parameter is defined in accordance with JEDEC Standard 65.

NOTE 4: These parameters are guaranteed by design. Not tested in production.

**Table 6C. AC Characteristics,  $V_{DD} = V_{DDO} = 1.2V \pm 5\%$ ,  $T_A = 0^\circ C$  to  $70^\circ C$** 

Symbol	Parameter		Test Conditions	Minimum	Typical	Maximum	Units
$f_{MAX}$	Output Frequency	Using External Crystal		10		40	MHz
		Using External Clock Source; NOTE 1		1		100	MHz
$t_{sk(o)}$	Output Skew; NOTE 2, 3					90	ps
$t_{jit}$	RMS Phase Jitter (Random)		25MHz, Integration Range: 100Hz – 1MHz		0.7		ps
$t_R / t_F$	Output Rise/Fall Time		20% to 80%	350		800	ps
odc	Output Duty Cycle			44	50	56	%
$t_{EN}$	Output Enable Time; NOTE 4	ENABLE1				4	cycles
		ENABLE2				4	cycles
$t_{DIS}$	Output Disable Time; NOTE 4	ENABLE1				4	cycles
		ENABLE2				4	cycles

NOTE: Electrical parameters are guaranteed over the specified ambient operating temperature range, which is established when the device is mounted in a test socket with maintained transverse airflow greater than 500 lpm. The device will meet specifications after thermal equilibrium has been reached under these conditions.

All parameters measured at  $f \leq 40\text{MHz}$  using a crystal input unless noted otherwise. Outputs terminated with  $50\Omega$  to  $V_{DDO}/2$ .

NOTE 1: XTAL\_IN can be overdriven by an external source.

NOTE 2: Defined as skew between outputs at the same supply voltage and with equal load conditions. Measured at  $V_{DDO}/2$ .

NOTE 3: This parameter is defined in accordance with JEDEC Standard 65.

NOTE 4: These parameters are guaranteed by design. Not tested in production.

**Table 6D. AC Characteristics,  $V_{DD} = 1.8V \pm 0.2V$ ,  $V_{DDO} = 1.5V \pm 0.1V$ ,  $T_A = 0^\circ C$  to  $70^\circ C$** 

Symbol	Parameter		Test Conditions	Minimum	Typical	Maximum	Units
$f_{MAX}$	Output Frequency	Using External Crystal		10		40	MHz
		Using External Clock Source; NOTE 1		1		100	MHz
$t_{sk(o)}$	Output Skew; NOTE 2, 3					90	ps
$t_{jit}$	RMS Phase Jitter (Random)		25MHz, Integration Range: 100Hz – 1MHz		0.18		ps
$t_R / t_F$	Output Rise/Fall Time		20% to 80%	300		650	ps
odc	Output Duty Cycle			40	50	60	%
$t_{EN}$	Output Enable Time; NOTE 4	ENABLE1				4	cycles
		ENABLE2				4	cycles
$t_{DIS}$	Output Disable Time; NOTE 4	ENABLE1				4	cycles
		ENABLE2				4	cycles

NOTE: Electrical parameters are guaranteed over the specified ambient operating temperature range, which is established when the device is mounted in a test socket with maintained transverse airflow greater than 500 lpm. The device will meet specifications after thermal equilibrium has been reached under these conditions.

All parameters measured at  $f \leq 40\text{MHz}$  using a crystal input unless noted otherwise. Outputs terminated with  $50\Omega$  to  $V_{DDO}/2$ .

NOTE 1: XTAL\_IN can be overdriven by an external source.

NOTE 2: Defined as skew between outputs at the same supply voltage and with equal load conditions. Measured at  $V_{DDO}/2$ .

NOTE 3: This parameter is defined in accordance with JEDEC Standard 65.

NOTE 4: These parameters are guaranteed by design. Not tested in production.

**Table 6E. AC Characteristics,  $V_{DD} = 1.8V \pm 0.2V$ ,  $V_{DDO} = 1.2V \pm 5\%$ ,  $T_A = 0^\circ C$  to  $70^\circ C$** 

Symbol	Parameter		Test Conditions	Minimum	Typical	Maximum	Units
$f_{MAX}$	Output Frequency	Using External Crystal		10		40	MHz
		Using External Clock Source; NOTE 1		1		100	MHz
$t_{sk(o)}$	Output Skew; NOTE 2, 3					95	ps
$t_{jit}$	RMS Phase Jitter (Random)		25MHz, Integration Range: 100Hz – 1MHz		0.2		ps
$t_R / t_F$	Output Rise/Fall Time		20% to 80%	350		800	ps
odc	Output Duty Cycle			42	50	58	%
$t_{EN}$	Output Enable Time; NOTE 4	ENABLE1				4	cycles
		ENABLE2				4	cycles
$t_{DIS}$	Output Disable Time; NOTE 4	ENABLE1				4	cycles
		ENABLE2				4	cycles

NOTE: Electrical parameters are guaranteed over the specified ambient operating temperature range, which is established when the device is mounted in a test socket with maintained transverse airflow greater than 500 lpm. The device will meet specifications after thermal equilibrium has been reached under these conditions.

All parameters measured at  $f \leq 40\text{MHz}$  using a crystal input unless noted otherwise. Outputs terminated with  $50\Omega$  to  $V_{DDO}/2$ .

NOTE 1: XTAL\_IN can be overdriven by an external source.

NOTE 2: Defined as skew between outputs at the same supply voltage and with equal load conditions. Measured at  $V_{DDO}/2$ .

NOTE 3: This parameter is defined in accordance with JEDEC Standard 65.

NOTE 4: These parameters are guaranteed by design. Not tested in production.

**Table 6F. AC Characteristics,  $V_{DD} = 1.5V \pm 0.1V$ ,  $V_{DDO} = 1.2V \pm 5\%$ ,  $T_A = 0^\circ C$  to  $70^\circ C$** 

Symbol	Parameter	Test Conditions	Minimum	Typical	Maximum	Units
$f_{MAX}$	Output Frequency	Using External Crystal	10		40	MHz
		Using External Clock Source; NOTE 1	1		100	MHz
$t_{sk(o)}$	Output Skew; NOTE 2, 3				90	ps
$t_{jit}$	RMS Phase Jitter (Random)	25MHz, Integration Range: 100Hz – 1MHz		0.34		ps
$t_R / t_F$	Output Rise/Fall Time	20% to 80%	350		800	ps
odc	Output Duty Cycle		42	50	58	%
$t_{EN}$	Output Enable Time; NOTE 4	ENABLE1			4	cycles
		ENABLE2			4	cycles
$t_{DIS}$	Output Disable Time; NOTE 4	ENABLE1			4	cycles
		ENABLE2			4	cycles

NOTE: Electrical parameters are guaranteed over the specified ambient operating temperature range, which is established when the device is mounted in a test socket with maintained transverse airflow greater than 500 lfm. The device will meet specifications after thermal equilibrium has been reached under these conditions.

All parameters measured at  $f \leq 40\text{MHz}$  using a crystal input unless noted otherwise. Outputs terminated with  $50\Omega$  to  $V_{DDO}/2$ .

NOTE 1: XTAL\_IN can be overdriven by an external source.

NOTE 2: Defined as skew between outputs at the same supply voltage and with equal load conditions. Measured at  $V_{DDO}/2$ .

NOTE 3: This parameter is defined in accordance with JEDEC Standard 65.

NOTE 4: These parameters are guaranteed by design. Not tested in production.

### Typical Phase Noise at 25MHz (1.8V Core, 1.8V Output)

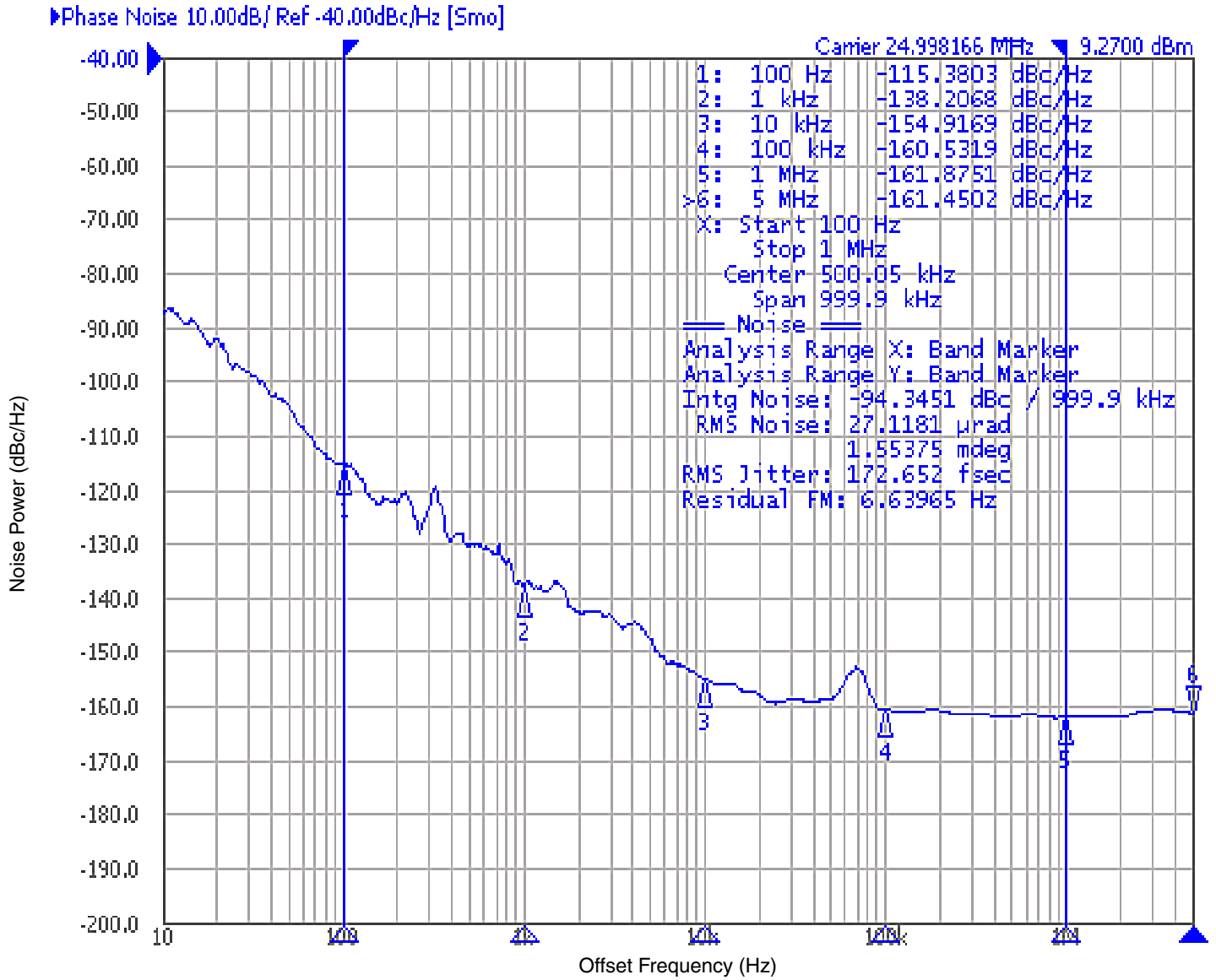

## Parameter Measurement Information

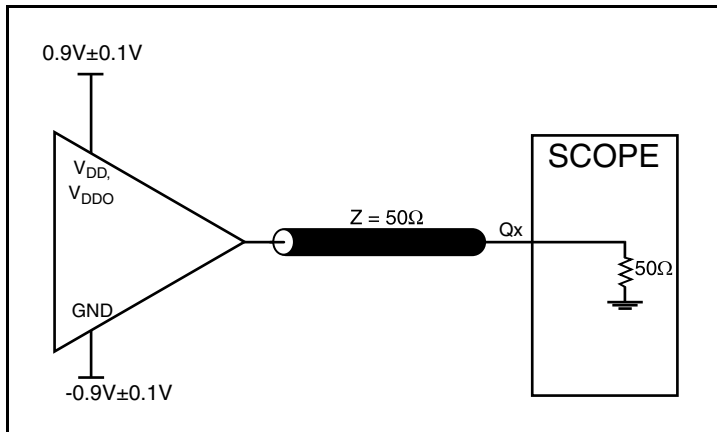

1.8V Core/1.8V LVCMOS Output Load Test Circuit

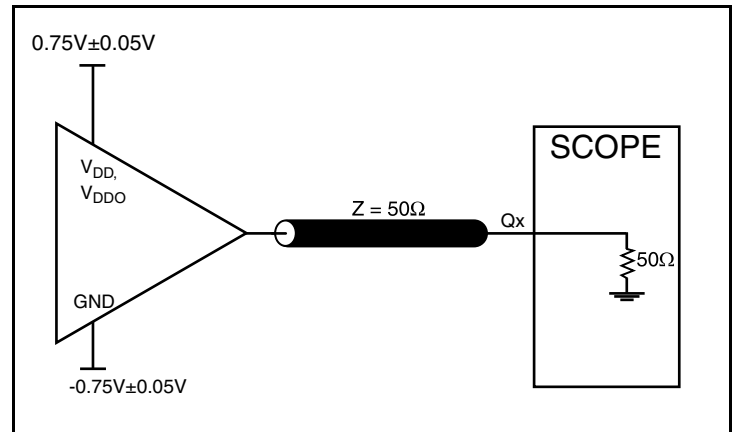

1.5V Core/1.5V LVCMOS Output Load Test Circuit

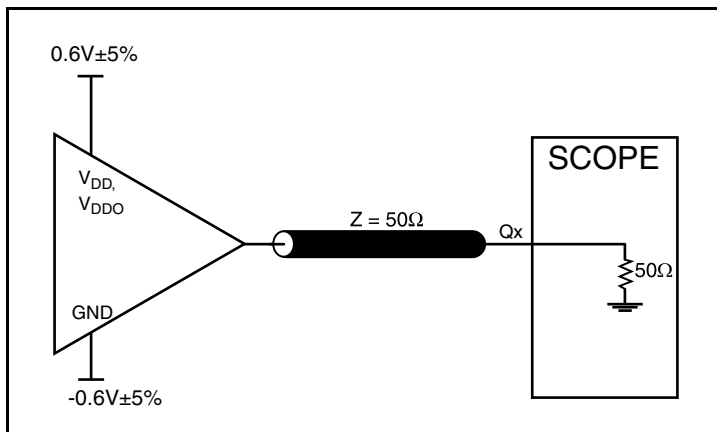

1.2V Core/1.2V LVCMOS Output Load Test Circuit

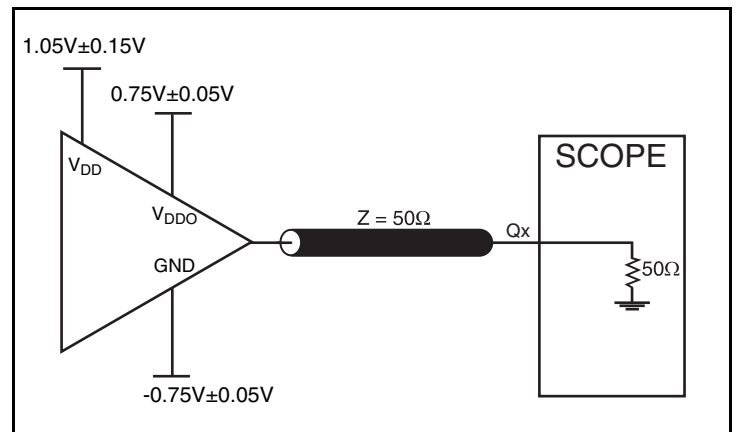

1.8V Core/1.5V LVCMOS Output Load Test Circuit

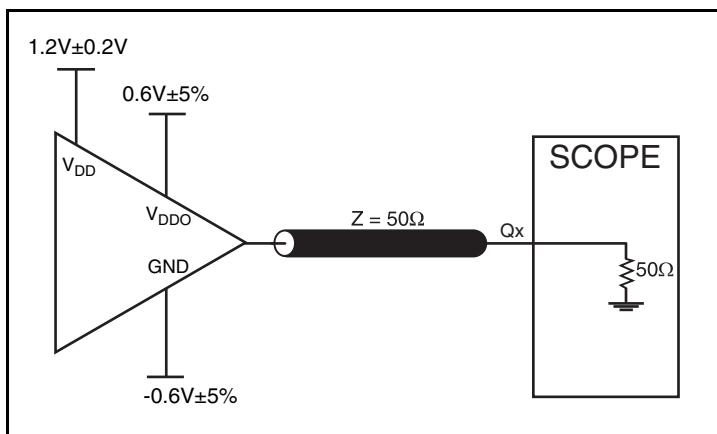

1.8V Core/1.2V LVCMOS Output Load Test Circuit

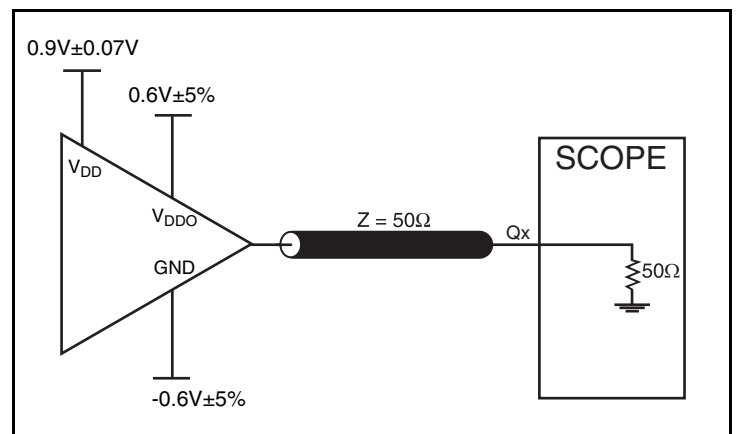

1.5V Core/1.2V LVCMOS Output Load Test Circuit

## Parameter Measurement Information, continued

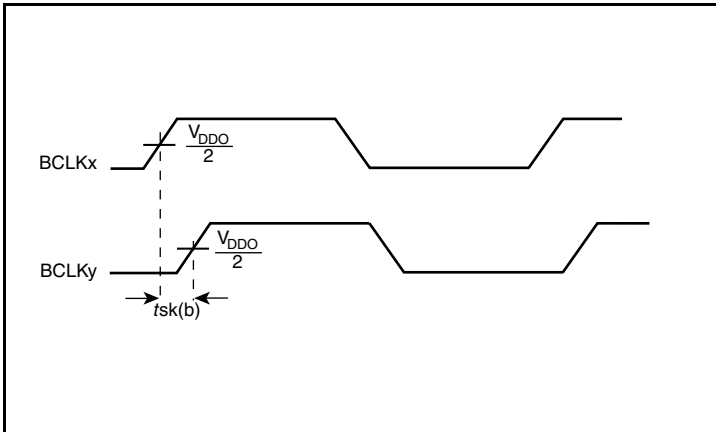

**Output Skew**

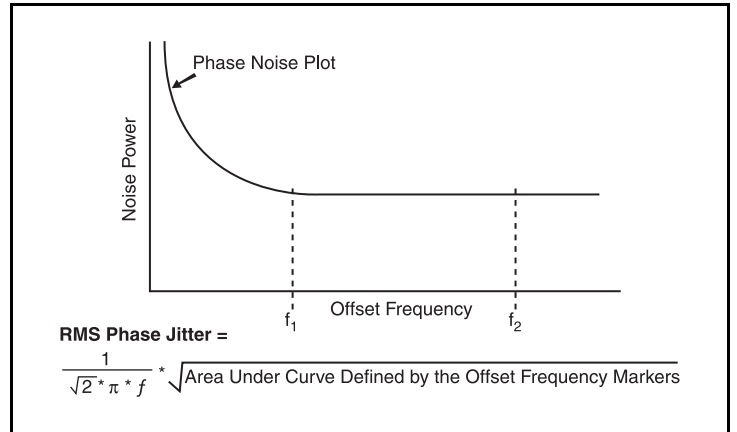

**RMS Phase Jitter**

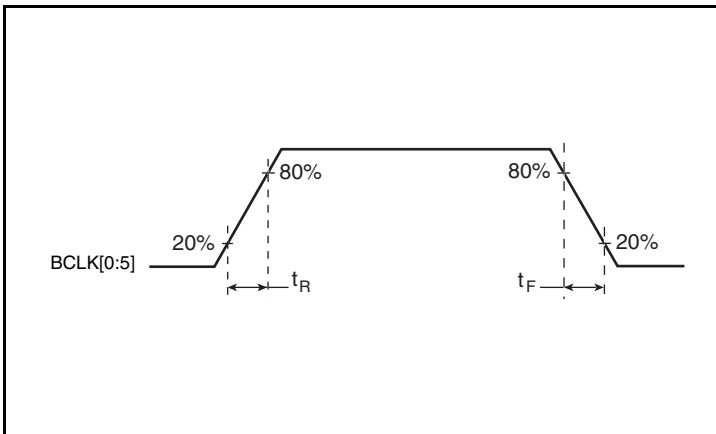

**Output Rise/Fall Time**

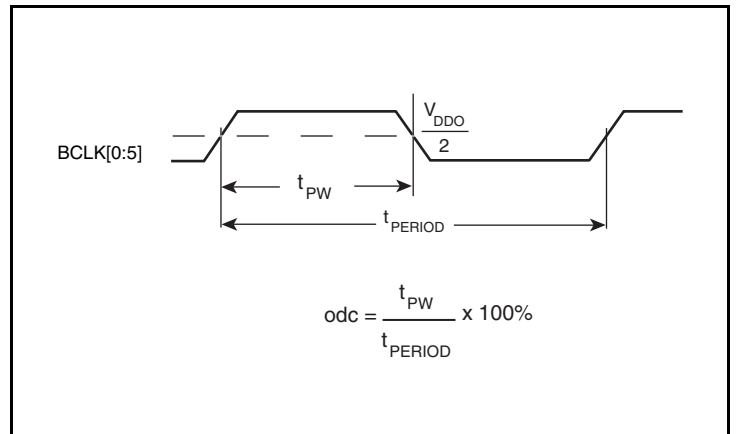

**Output Duty Cycle/Pulse Width/Period**

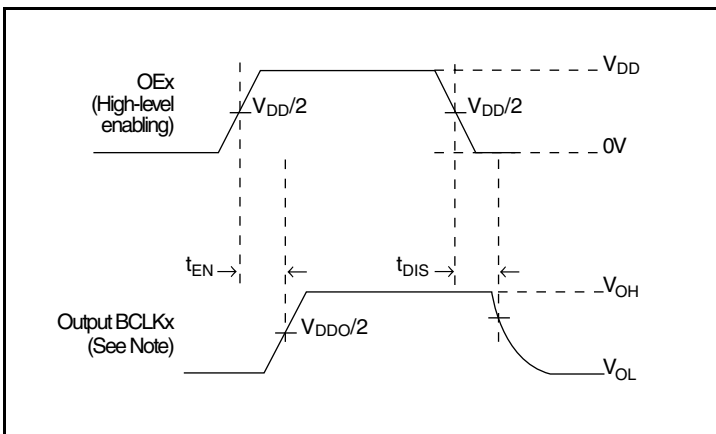

**Output Enable/Disable**

## Application Information

### Recommendations for Unused Output Pins

#### Outputs:

##### LVC MOS Outputs

All unused LVC MOS output can be left floating. There should be no trace attached.

### Crystal Input Interface

The 83905-01 has been characterized with 18pF parallel resonant crystals. The capacitor values, C1 and C2, shown in *Figure 2* below were determined using an 18pF parallel resonant crystal and were

chosen to minimize the ppm error. The optimum C1 and C2 values can be slightly adjusted for different board layouts.

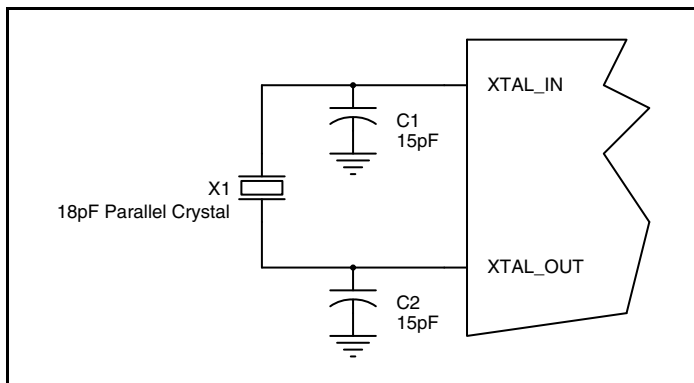
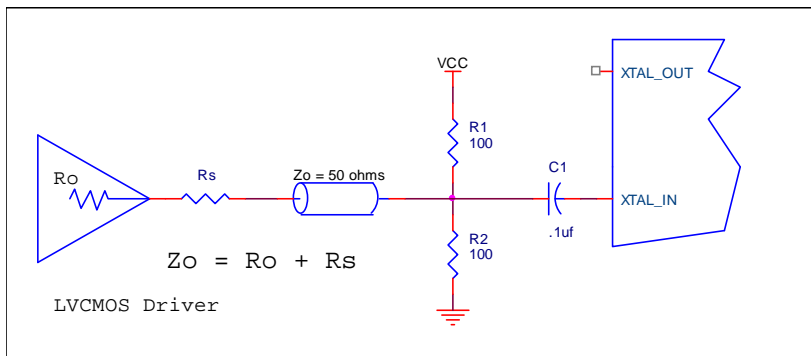

**Figure 2. Crystal Input Interface**

## Overdriving the XTAL Interface

The XTAL\_IN input can be overdriven by an LVCMOS driver or by one side of a differential driver through an AC coupling capacitor. The XTAL\_OUT pin can be left floating. The amplitude of the input signal should be between 500mV and 1.8V and the slew rate should not be less than 0.2V/ns. For 3.3V LVCMOS inputs, the amplitude must be reduced from full swing to at least half the swing in order to prevent signal interference with the power rail and to reduce internal noise. *Figure 3A* shows an example of the interface diagram for a high speed 3.3V LVCMOS driver. This configuration requires that the sum of the output impedance of the driver ( $R_o$ ) and the series resistance ( $R_s$ ) equals the transmission line impedance. In addition, matched termination at the crystal input will attenuate the signal in half. This

can be done in one of two ways. First,  $R_1$  and  $R_2$  in parallel should equal the transmission line impedance. For most 50Ω applications,  $R_1$  and  $R_2$  can be 100Ω. This can also be accomplished by removing  $R_1$  and changing  $R_2$  to 50Ω. The values of the resistors can be increased to reduce the loading for a slower and weaker LVCMOS driver. *Figure 3B* shows an example of the interface diagram for an LVPECL driver. This is a standard LVPECL termination with one side of the driver feeding the XTAL\_IN input. It is recommended that all components in the schematics be placed in the layout. Though some components might not be used, they can be utilized for debugging purposes. The datasheet specifications are characterized and guaranteed by using a quartz crystal as the input.



**Figure 3A. General Diagram for LVCMOS Driver to XTAL Input Interface**

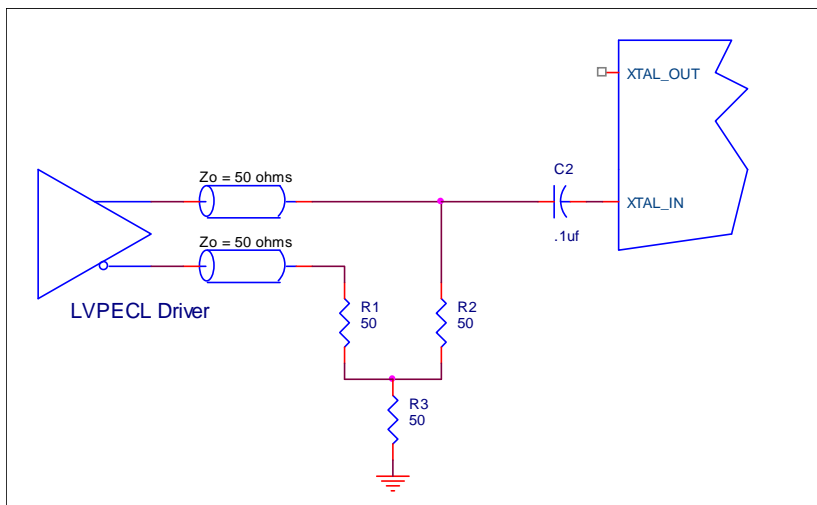
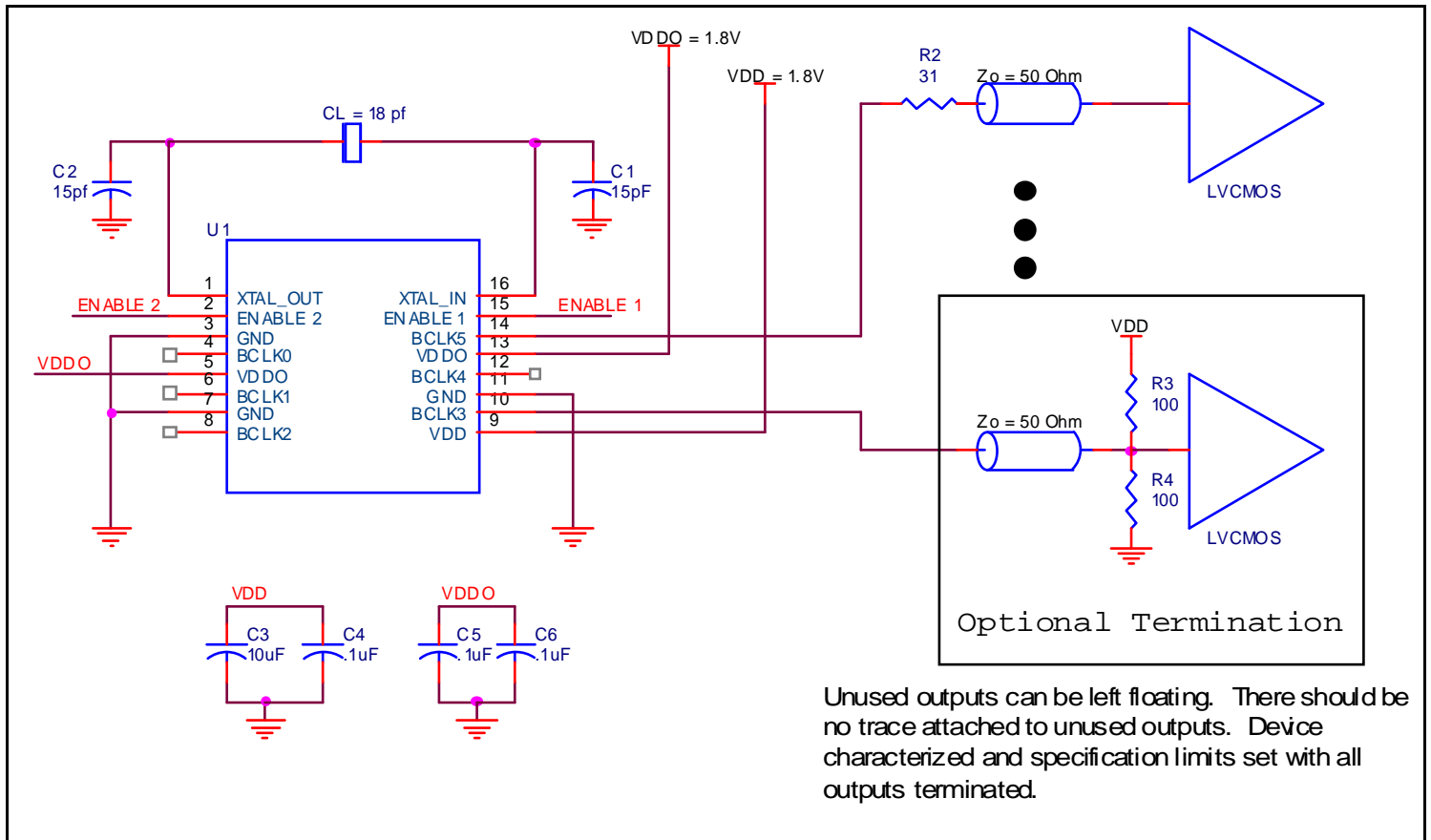

**Figure 3B. General Diagram for LVPECL Driver to XTAL Input Interface**

## Schematic Example

Figure 4 shows an example of the 83905-01 application schematic. In this example, the device is operated at  $V_{DD} = V_{DDO} = 1.8V$ . The decoupling capacitors should be located as close as possible to the power pin. The input is driven by an 18pF load resonant quartz crystal. The tuning capacitors C1 and C2 are fairly accurate, but

minor adjustments might be required. For the LVCMOS output drivers, two termination examples are shown in this schematic. For additional termination examples, see LVCMOS Termination Application Note.



Unused outputs can be left floating. There should be no trace attached to unused outputs. Device characterized and specification limits set with all outputs terminated.

Figure 4. 83905-01 Schematic Layout

## Power Considerations

This section provides information on power dissipation and junction temperature for the 83905-01. Equations and example calculations are also provided.

### 1. Power Dissipation.

The total power dissipation for the 83905-01 is the sum of the core power plus the analog power plus the power dissipated due to the load. The following is the power dissipation for  $V_{DD} = 1.8V + 0.2V = 2.0V$ , which gives worst case results.

- Power (core)<sub>MAX</sub> =  $V_{DD\_MAX} * I_{DD} = 2V * 10mA = \mathbf{20mW}$
- Output Impedance  $R_{OUT}$  Power Dissipation due to Loading  $50\Omega$  to  $V_{DD}/2$   
Output Current  $I_{OUT} = V_{DD\_MAX} / [2 * (50\Omega + R_{OUT})] = 2V / [2 * (50\Omega + 17\Omega)] = \mathbf{14.9mA}$
- Power Dissipation on the  $R_{OUT}$  per LVCMOS output  
Power ( $R_{OUT}$ ) =  $R_{OUT} * (I_{OUT})^2 = 17\Omega * (14.9mA)^2 = \mathbf{3.8mW}$  per output
- Total Power Dissipation on the  $R_{OUT}$   
**Total Power ( $R_{OUT}$ ) =  $3.8mW * 6 = \mathbf{22.8mW}$**

### Dynamic Power Dissipation at 100MHz

$$\text{Power (100MHz)} = C_{PD} * \text{Frequency} * (V_{DD})^2 = 12pF * 100MHz * (2V)^2 = \mathbf{4.8mW}$$
 per output  
**Total Power (100MHz) =  $4.8mW * 6 = \mathbf{28.8mW}$**

### Total Power Dissipation

- **Total Power**  
= Power (core)<sub>MAX</sub> + Total Power ( $R_{OUT}$ ) + Total Power (100MHz)  
=  $20mW + 22.8mW + 28.8mW$   
= **71.6mW**

### 2. Junction Temperature.

Junction temperature,  $T_j$ , is the temperature at the junction of the bond wire and bond pad and directly affects the reliability of the device. The maximum recommended junction temperature is  $125^\circ\text{C}$ .

The equation for  $T_j$  is as follows:  $T_j = \theta_{JA} * Pd\_total + T_A$

$T_j$  = Junction Temperature

$\theta_{JA}$  = Junction-to-Ambient Thermal Resistance

$Pd\_total$  = Total Device Power Dissipation (example calculation is in section 1 above)

$T_A$  = Ambient Temperature

In order to calculate junction temperature, the appropriate junction-to-ambient thermal resistance  $\theta_{JA}$  must be used. Assuming no air flow and a multi-layer board, the appropriate value is  $100.3^\circ\text{C/W}$  per Table 7 below.

Therefore,  $T_j$  for an ambient temperature of  $70^\circ\text{C}$  with all outputs switching is:

$$70^\circ\text{C} + 0.072W * 100.3^\circ\text{C/W} = 77.2^\circ\text{C}. \text{ This is below the limit of } 125^\circ\text{C}.$$

This calculation is only an example.  $T_j$  will obviously vary depending on the number of loaded outputs, supply voltage, air flow and the type of board (multi-layer).

**Table 7. Thermal Resistance  $\theta_{JA}$  for 16-Lead TSSOP, Forced Convection**

Meters per Second	$\theta_{JA}$ by Velocity		
	0	1	2.5
Multi-Layer PCB, JEDEC Standard Test Boards	$100.3^\circ\text{C/W}$	$96.0^\circ\text{C/W}$	$93.9^\circ\text{C/W}$

## Reliability Information

**Table 8A.  $\theta_{JA}$  vs. Air Flow Table for a 16-Lead TSSOP**

$\theta_{JA}$ vs. Air Flow			
Meters per Second	0	1	2.5
Multi-Layer PCB, JEDEC Standard Test Boards	100.3°C/W	96.0°C/W	93.9°C/W

**Table 8B.  $\theta_{JA}$  vs. Air Flow Table for a 20-Lead VFQFN**

$\theta_{JA}$ vs. Air Flow			
Meters per Second	0	1	2.5
Multi-Layer PCB, JEDEC Standard Test Boards	57.5°C/W	50.3°C/W	45.1°C/W

## Transistor Count

The transistor count for 83905-01: 505

# 16-Lead TSSOP Package Outline and Package Dimensions

## Package Outline - G Suffix for 16-Lead TSSOP

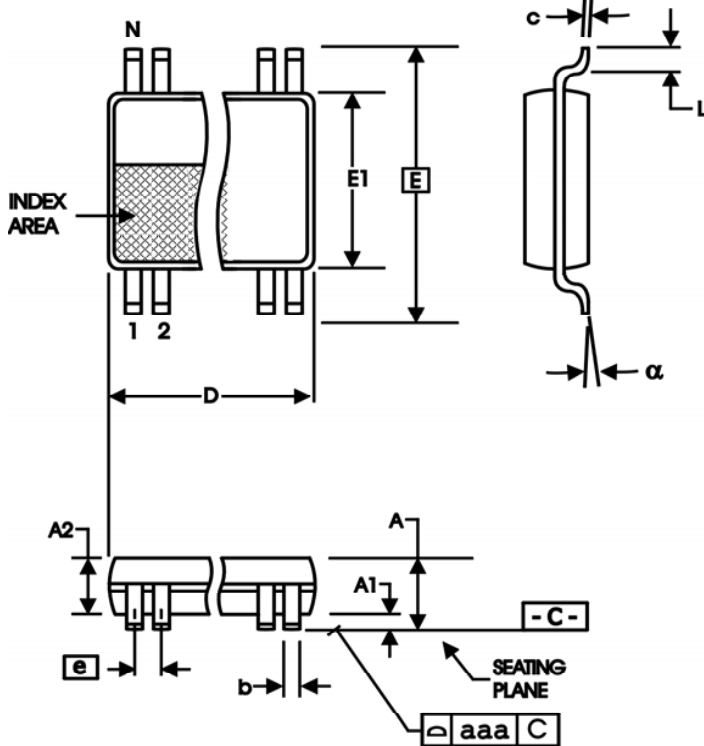

Table 9A. Package Dimensions for 16-Lead TSSOP

All Dimensions in Millimeters		
Symbol	Minimum	Maximum
N	16	
A		1.20
A1	0.05	0.15
A2	0.80	1.05
b	0.19	0.30
c	0.09	0.20
D	4.90	5.10
E	6.40 Basic	
E1	4.30	4.50
e	0.65 Basic	
L	0.45	0.75
$\alpha$	0°	8°
aaa		0.10

Reference Document: JEDEC Publication 95, MO-153

## 20-Lead VFQFN Package Outline and Package Dimensions

### Package Outline - K Suffix for 20-Lead VFQFN

TOP VIEW

SIDE VIEW

BOTTOM VIEW

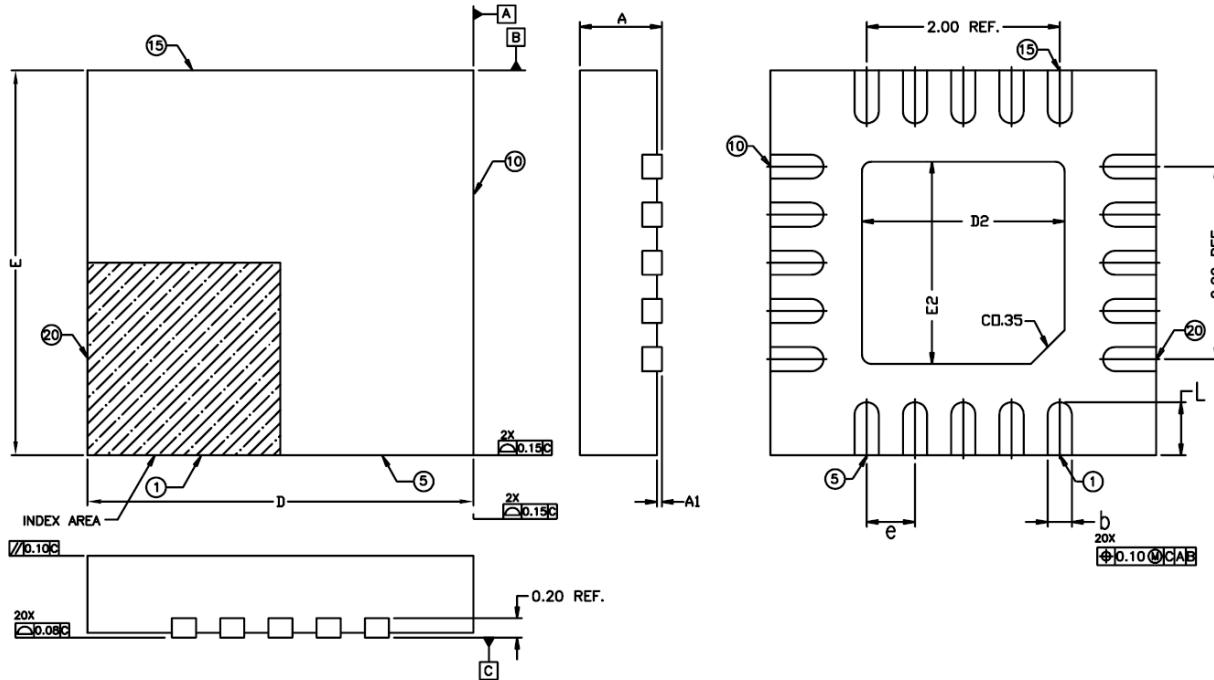

Table 9C. Package Dimensions for 20-Lead VFQFN

All Dimensions in Millimeters			
Symbol	Minimum	Nom	Maximum
$b$	0.20	0.25	0.30
$D$	3.90	4.00	4.10
$E$	3.90	4.00	4.10
$D2$	1.95	2.10	2.25
$E2$	1.95	2.10	2.25
$L$	0.45	0.55	0.65
$e$	0.50 BSC		
$N$	20		
$A$	0.80	0.90	1.00
$A1$	0.00	0.02	0.05
$A3$	0.2 REF		

Reference Document: JEDEC Publication 95, MO-220

#### NOTE:

The drawing and dimension data originate from IDT package outline drawing PSC-4170, rev03.

1. Dimensions and tolerances conform to ASME Y14.5M-1994
2. All dimensions are in millimeters. All angles are in degrees.
3.  $N$  is the total number of terminals.
4. All specifications comply with JEDEC MO-220.

## Ordering Information

Table 10. Ordering Information

Part/Order Number	Marking	Package	Shipping Packaging	Temperature
83905AG-01LF	3905A01L	16-Lead TSSOP, Lead-Free	Tube	0°C to 70°C
83905AG-01LFT	3905A01L	16-Lead TSSOP, Lead-Free	Tape & Reel	0°C to 70°C
83905AK-01LF	5A01L	20-Lead VFQFN, Lead-Free	Tray	0°C to 70°C
83905AK-01LFT	5A01L	20-Lead VFQFN, Lead-Free	Tape & Reel	0°C to 70°C

NOTE: Parts that are ordered with an "LF" suffix to the part number are the Pb-Free configuration and are RoHS compliant.



**Corporate Headquarters**  
6024 Silver Creek Valley Road  
San Jose, CA 95138 USA

**Sales**  
1-800-345-7015 or 408-284-8200  
Fax: 408-284-2775  
www.IDT.com

**Tech Support**  
email: [clocks@idt.com](mailto:clocks@idt.com)

DISCLAIMER Integrated Device Technology, Inc. (IDT) and its subsidiaries reserve the right to modify the products and/or specifications described herein at any time and at IDT's sole discretion. All information in this document, including descriptions of product features and performance, is subject to change without notice. Performance specifications and the operating parameters of the described products are determined in the independent state and are not guaranteed to perform the same way when installed in customer products. The information contained herein is provided without representation or warranty of any kind, whether express or implied, including, but not limited to, the suitability of IDT's products for any particular purpose, an implied warranty of merchantability, or non-infringement of the intellectual property rights of others. This document is presented only as a guide and does not convey any license under intellectual property rights of IDT or any third parties.

IDT's products are not intended for use in applications involving extreme environmental conditions or in life support systems or similar devices where the failure or malfunction of an IDT product can be reasonably expected to significantly affect the health or safety of users. Anyone using an IDT product in such a manner does so at their own risk, absent an express, written agreement by IDT.

While the information presented herein has been checked for both accuracy and reliability, Integrated Device Technology (IDT) assumes no responsibility for either its use or for the infringement of any patents or other rights of third parties, which would result from its use. No other circuits, patents, or licenses are implied. This product is intended for use in normal commercial applications. Any other applications, such as those requiring extended temperature ranges, high reliability or other extraordinary environmental requirements are not recommended without additional processing by IDT. IDT reserves the right to change any circuitry or specifications without notice. IDT does not authorize or warrant any IDT product for use in life support devices or critical medical instruments.

Integrated Device Technology, IDT and the IDT logo are registered trademarks of IDT. Product specification subject to change without notice. Other trademarks and service marks used herein, including protected names, logos and designs, are the property of IDT or their respective third party owners.

Copyright ©2015 Integrated Device Technology, Inc.. All rights reserved.

# Mouser Electronics

Authorized Distributor

Click to View Pricing, Inventory, Delivery & Lifecycle Information:

[IDT \(Integrated Device Technology\):](#)

[83905AG-01LF](#)