

Max. 79 m³/h

DC axial fans

□ 80 x 25 mm



- **Material:** Housing: GRP¹⁾ (PBT)
Impeller: GRP¹⁾ (PA)
 - **Direction of air flow:** Exhaust over struts
 - **Direction of rotation:** Counterclockwise, looking towards rotor
 - **Connection:** Via single wires AWG 24, TR 64
 - **Highlights:** Some models are suitable for use at high ambient temperatures up to 85 °C.
 - **Weight:** 95 g
- **Possible special versions:** (See chapter DC fans - specials)
 - Speed signal
 - Go / NoGo alarm
 - Alarm with speed limit
 - External temperature sensor
 - Internal temperature sensor
 - PWM control input
 - Analog control input
 - Moisture protection
 - Degree of protection: IP 54 / IP 68

1) Fiberglass-reinforced plastic

Series 8400 N																										
Nominal data	Air flow		Nominal voltage		Voltage range		Sound pressure level		Sound power level		Sinter sleeve bearings		Power consumption		Nominal speed		Temperature range		Service life L ₁₀ (40 °C)		Service life L ₁₀ (T _{max})		Life expectancy L ₁₀ IPC		Curve	
	Type	m ³ /h	cfm	VDC	VDC	dB(A)	Bel(A)	□ / ■	Watts	rpm ¹	°C	Hours	Hours	Hours	Hours	Hours	Hours	Hours	Hours	Hours	Hours	Hours	Hours	Hours	Hours	Hours
8412 NGL	33	19.4	12	8...15	12	3.5	□	0.5	1 500	-20...+85	80 000 / 27 500	135 000	①													
8412 NLE	33	19.4	12	8...15	17	3.7	■	0.3	1 500	-20...+85	80 000 / 27 500	135 000	①													
8412 NGMLE	45	26.5	12	8...15	19	3.9	□	0.9	2 050	-20...+80	80 000 / 32 500	135 000	②													
8412 NMLE	45	26.5	12	8...15	21	4.0	■	0.6	2 050	-20...+85	80 000 / 27 500	135 000	②													
8412 NGME	58	34.1	12	8...15	26	4.3	□	1.4	2 600	-20...+75	80 000 / 35 000	135 000	③													
8412 NME	58	34.1	12	8...15	27	4.4	■	1.0	2 600	-20...+75	80 000 / 35 000	135 000	③													
8412 NG	69	40.6	12	8...15	32	4.7	□	2.0	3 100	-20...+70	70 000 / 35 000	117 500	④													
8412 N	69	40.6	12	8...15	32	4.7	■	1.7	3 100	-20...+70	70 000 / 35 000	117 500	④													
8412 NH	79	46.5	12	8...13.2	37	5.0	■	2.1	3 600	-20...+70	70 000 / 35 000	117 500	⑤													
8412 NH-217	79	46.5	12	8...15	37	5.0	■	2.5	3 600	-20...+70	70 000 / 35 000	117 500	⑤													
8414 NGL	33	19.4	24	18...28	12	3.5	□	0.9	1 500	-20...+70	80 000 / 40 000	135 000	①													
8414 NL	33	19.4	24	18...28	17	3.7	■	0.8	1 500	-20...+70	80 000 / 40 000	135 000	①													
8414 NGML	45	26.5	24	18...28	19	3.9	□	1.2	2 050	-20...+70	80 000 / 40 000	135 000	②													
8414 NML	45	26.5	24	18...28	21	4.0	■	1.1	2 050	-20...+70	80 000 / 40 000	135 000	②													
8414 NGM	58	34.1	24	18...28	26	4.3	□	1.4	2 600	-20...+70	80 000 / 40 000	135 000	③													
8414 NM	58	34.1	24	18...28	27	4.4	■	1.4	2 600	-20...+70	80 000 / 40 000	135 000	③													
8414 NG	69	40.6	24	18...28	32	4.7	□	2.2	3 100	-20...+70	70 000 / 35 000	117 500	④													
8414 N	69	40.6	24	18...28	32	4.7	■	1.8	3 100	-20...+70	70 000 / 35 000	117 500	④													
8414 NH	79	46.5	24	18...26	37	5.0	■	2.4	3 600	-20...+70	70 000 / 35 000	117 500	⑤													
8414 NH-221	79	46.5	24	18...28	37	5.0	■	2.2	3 600	-20...+70	70 000 / 35 000	117 500	⑤													
8418 N	69	40.6	48	36...56	32	4.7	■	2.0	3 100	-20...+70	70 000 / 35 000	117 500	④													

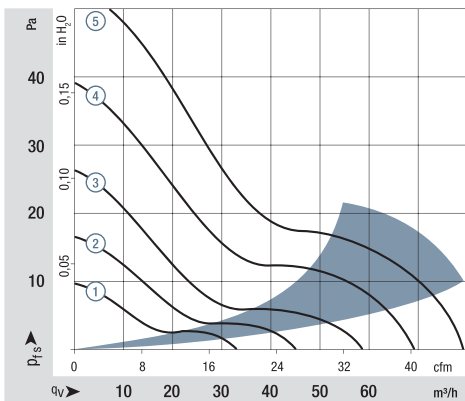

Air performance measured according to: ISO 5801.
Installation category A, without contact protection.
Noise: Total sound power level L_{WA} ISO 103002 measured on a hemisphere with a radius of 2 m.
Sound pressure level L_{pA} measured at 1 m distance from fan axis.
The values given are applicable only under the specified measuring conditions and may differ depending on the installation conditions.
In the event of deviation from the standard configuration, the parameters must be checked after installation!
For detailed information see <http://www.ebmpapst.com/general conditions>

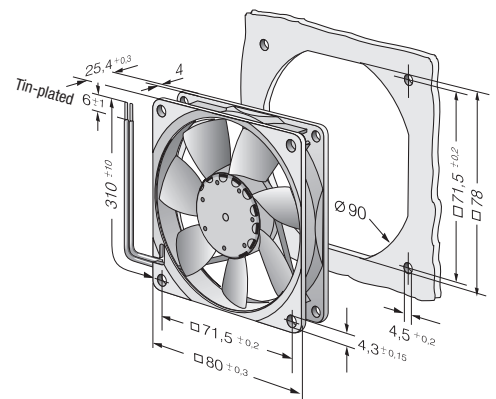

Mouser Electronics

Authorized Distributor

Click to View Pricing, Inventory, Delivery & Lifecycle Information:

[ebm-papst:](#)

[8412NGMLE](#) [8412N](#) [8412NME](#) [8412NLE](#) [8412NGME](#) [8412NM](#) [8412NL](#) [8412NGLE](#) [8412NMLE](#) [8412](#) [8414](#)
[8414NGH](#) [8412NG](#) [8412NGH](#) [8412NH](#) [8414N](#) [8414NG](#) [8414NGL](#) [8414NGM](#) [8414NGML](#) [8414NH](#) [8414NL](#)
[8414NM](#) [8414NML](#) [8412NH-217](#) [8414NH-221](#) [8418N](#) [8412N/2GHP](#) [8412N/2GH](#) [8414N/2GL](#) [8414N/2G](#) [8412N/2H](#)
[8412N/2G](#) [8412N/12H](#) [8412N/2GMLE](#) [8412N/12GH](#) [8412NH-166](#) [8412N/2GL](#) [8414NHR-122](#) [8418N/2H](#)
[8412N/12ML-250](#) [8412NGL](#) [8412NGR](#) [8412NGM](#) [8414NGH-222](#) [8412NGML](#)