

iMcV-Giga-FiberLinX-II

DS-iMcV-Giga-FiberLinX-II-1613
© 2013 B&B Electronics. All rights reserved.

SNMP-MANAGEABLE OPTICAL ETHERNET DEMARCATION UNIT/MEDIA CONVERTER 10/100/1000 MBPS ETHERNET

A Powerful Optical Demarcation Device Combining Media Conversion with Carrier Grade Delivery of Transparent LAN Services.



Features and Benefits

Secure and Flexible Solution

- VLAN-tagging and Q-in-Q (Extra-Tagging) segregates customer traffic
- Preserves complete end-to-end fiber connection and data integrity via SNMP management
- All management traffic remains isolated from the remote LAN
- IEEE 802.1Q VLAN and 802.1p QoS compliant
- SFP connectors available

Features and Functionality

- Transparency feature allows VLAN and non-VLAN traffic on same port
- Supports 802.3ah OAM (Operation, Administration & Management)
- Provides differential priority
- Bi-directional bandwidth control
- Allows remote configuration
- Features powerful LinkLoss, FiberAlert and loopback functionality for troubleshooting

Minimizes Networking Costs

- Avoids unnecessary service calls
- Allows replacement of expensive optical switches with inexpensive copper switches

The iMcV-Giga-FiberLinX-II media converter solution connects a host/remote network over fiber optics with bandwidth up to 1000 Mbps over both the Copper and the Fiber Ports. Building on the success of the original FiberLinX solutions, the iMcV-Giga-FiberLinX-II offers 10/100/1000 Mbps Ethernet, an advanced-feature set for network management and troubleshooting functions, including Extra-Tagging functionality.

With the iMcV-Giga-FiberLinX-II, administrators can observe the end-points, and the fiber link between them, as single management entities and not as separate elements. Host management traffic is not visible to the remote or customer network nor is access to the customer network required, guaranteeing end-to-end data integrity.

iMcV-Giga-FiberLinX-II allows for remote configuration and alerts administrators to any potential problems on the long-haul fiber run, provides vital information on link condition and reports data traffic statistics. In addition, it reduces the total cost of network equipment by functioning as a copper-to-fiber media converter, allowing deployment of lower cost copper switches at both ends of the fiber connection.

Application Example - Dual iMcV-Giga-FiberLinX-II Solution

When used in pairs, a iMcV-Giga-FiberLinX-II configured as a Host resides at the head-end while another iMcV-Giga-FiberLinX-II, configured as a Remote, installs at the customer location, typically on the network edge where a customer network meets the service provider infrastructure. Via SNMP, iMcV-Giga-FiberLinX-II monitors the entire link and ensures data integrity while remaining isolated and completely transparent to the customer LAN.

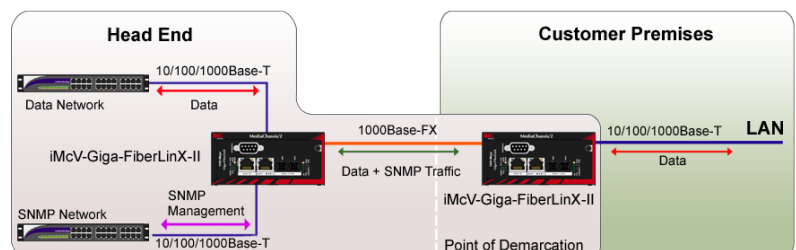

B&B ELECTRONICS

PRODUCT INFORMATION

VLAN Functionality on iMcV-Giga-FiberLinX-II

Service providers routinely use IEEE 802.1Q Virtual Local Area Network (VLAN) tagging to secure, separate and differentiate customer traffic. iMcV-Giga-FiberLinX-II enables service providers to support multiple VLAN-based applications.

- IEEE 802.1Q VLAN compatible
- Valid VLAN IDs are 1 to 4,094
- Port-based VLAN tagging
- Transparency Mode passes all data and respects the VLAN tag or lack thereof, i.e. allows a mixture of VLAN Tagged and Untagged traffic
- Configure to support VLAN trunking; iMcV-Giga-FiberLinX-II can trunk up to 32 VLAN IDs for data, plus an additional ID for SNMP (Transparency Mode disabled)
- IEEE 802.1p provides a 2-tier queue for differential prioritization of inbound and outbound traffic. For example, VoIP applications can be assigned a higher priority than data traffic

VLAN Tagging and Extra-Tagging

Support for IEEE 802.1Q Extra Tagging, also known as Q-in-Q, allows the iMcV-Giga-FiberLinX-II to more effectively route network VLAN traffic. Extra tagging simplifies management and configuration efforts for service providers who have customers using a range of VLAN IDs for different applications. Routing guidelines and other traffic rules can be programmed based on the extra tag, rather than being programmed for all of the potentially hundreds of individual VLAN IDs. Also, since a service provider's customers control their own internal VLAN settings, the extra tag is needed to make sure there is no overlap of VLAN IDs among customers, and to prevent traffic from different customers from becoming mixed. The extra tag is removed once the traffic is routed to its correct destination, a process that is transparent to customers.

Application Example - Single Remote Solution

A single iMcV-Giga-FiberLinX-II can be used as a single-solution (CPE) application. Install the sole iMcV-Giga-FiberLinX-II at the customer's network edge and configure the device as a standalone. Connect the iMcV-Giga-FiberLinX-II to a media converter at the central office or directly to a fiber switch. Manage the iMcV-Giga-FiberLinX-II from the central office.

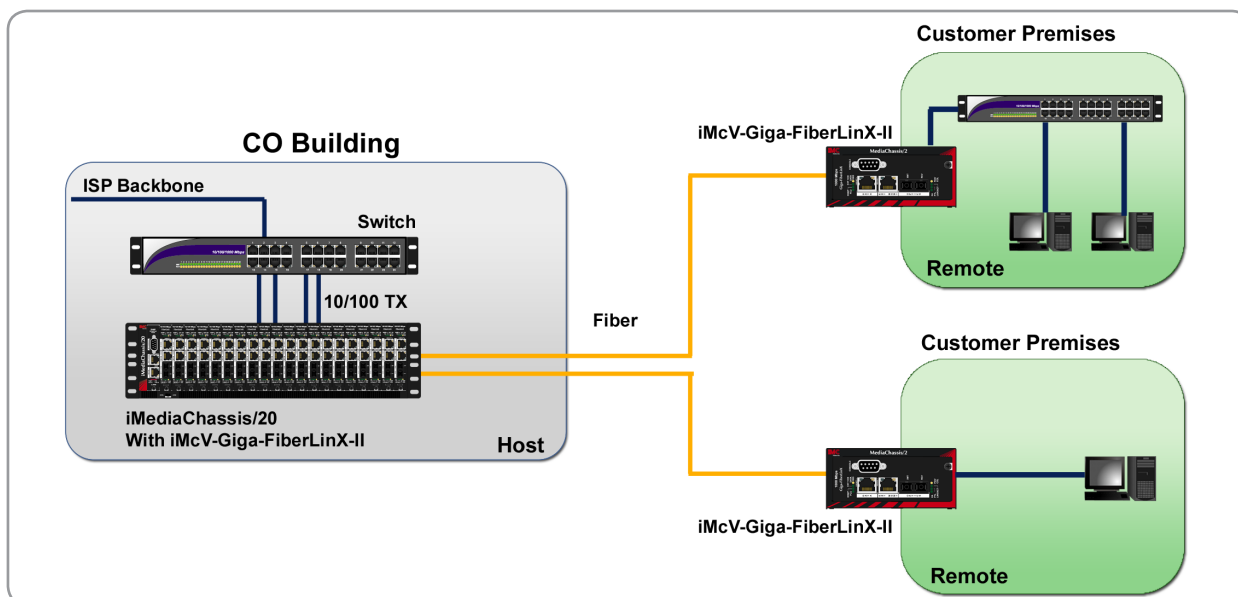

SNMP Management Made Easy

iMcV-Giga-FiberLinX-II features an SNMP management agent for monitoring the status and activity on copper and fiber ports at the remote end. Perform initial setup of the unit and modifications in the field via: iView² SNMP application, Telnet/TFTP, or local serial connection.

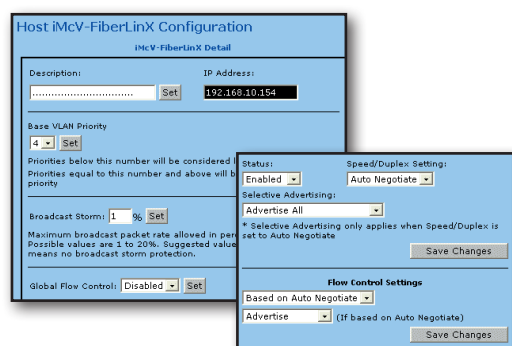

- Enable features and change configuration settings from central office
- Remote upgrades via Telnet/TFTP, serial port or iView²
- Monitor both units and the fiber in between
- Receive real-time monitoring and statistics
- Change bandwidth "on-the-fly" up to 1000 Mbps
- Create a secure management domain to isolate management domain broadcasts from TX Data ports on both units
- User-definable unit/port descriptions and information

Full-Featured iMcV-Giga-FiberLinX-II

From a central location, network operators are able to receive real-time device and traffic statistics on the remote CPE or other devices connected to the remote management port, allocate bandwidth, turn services on or off, initiate loopback testing, change customer VLAN settings and adjust QoS policies assigned to different traffic types.

Dedicated Management Port

The EXT MGMT port on the iMcV-Giga-FiberLinX-II provides the ability to physically isolate the management domain from the data domain, allowing users to manage edge devices and beyond while protecting the management domain from unwanted access.

Troubleshooting Features

FiberAlert and LinkLoss along with LEDs assist in diagnosing potential problems on fiber optic networks. Additionally, RMON and IFSTAT statistics are available.

Loopback Testing

Loops back all frames arriving on fiber port (except for the device's management traffic). When in Loopback mode, iMcV-Giga-FiberLinX-II drops the link on the twisted pair port.

Flexibility

Offering unparalleled flexibility, iMcV-Giga-FiberLinX-II supports multiple fiber types including multi-mode and single-mode as well as single-strand fiber, which can effectively double the capacity of installed fiber. Two Gigabit SFP ports available for WAN and LAN side fiber or copper SFP modules (SERDES and SGMII); SERDES (1000 Mbps), SGMII (10/100/1000 Mbps).

Choose from one of three different versions:

- One Gigabit Fiber WAN port, and one 10/100/1000 Mbps Twisted pair (RJ-45) LAN port (DATA)*
- One Gigabit SFP WAN port, ideal for either a fiber or copper SFP module, and one 10/100/1000 Mbps Twisted pair (RJ-45) LAN port (DATA)*
- Two Gigabit SFP ports for WAN and LAN side fiber or copper SFP modules

Each version includes a 10/100/1000 twisted pair port (EXT MGMT) for management (can also function as a serial port).

* For the two versions with a DATA port, the iMcV-Giga-FiberLinX-II provides auto-negotiation, automatic crossover detection, full or half duplex and selective advertising. The DATA port also features Flow Control in Full Duplex Mode (FDX) and Back Pressure Flow Control.

Bandwidth Limiting

With bandwidth throttling Network Operators can control customer bandwidth offering a range of revenue generating services.

Supports the Unified Management Agent (UMA)

The Unified Management Agent (UMA) allows users to manage all iMcV-Giga-FiberLinX-II modules installed in an IMC Networks iMediaChassis (and any connected remote modules) with a single IP address from a central location, conserving precious IP addresses. Additionally, UMA allows users to centrally manage and administer firmware upgrades over multiple devices, saving time.

Technical Specifications

General

- Preserves complete end-to-end fiber connection integrity
- Supports Extra Tagging (Q-in-Q)
- Supports 802.3ah OAM (Operation, Administration & Management)
- Bi-directional bandwidth control
- Read/write IEEE 802.1Q VLAN-tags
- QoS: IEEE 802.1p-based packet prioritization (2 queues [high/low] with 8 levels of priority)
- Layer 2 packet switching, store and forward operation
- Forwarding rate: 14,881 pps for 10 Mbps; 148,810 pps for 100 Mbps; 1,488,100 pps for 1000 Mbps
- Auto-Cross for MDI/MDIX
- Features Auto Negotiation and Selective Advertising
- Supports Half and Full-Duplex operation
- MTU: Supports over-sized (Jumbo) packets up to 12196 bytes

Security

- Password Control
- Multiple Access Levels: User Assigned Accounts & Access Levels

Management

- SNMP V1 and V2c compatible
- Includes GUI-based iView² software for remote management
- Monitors far-end (remote) status without a physical presence or separate connection
- IEEE 802.3x Flow Control
- Includes DHCP and TFTP clients
- Supports Telnet
- Includes loopback test modes (MAC swap)
- Includes LinkLoss and FiberAlert
- Supports Unified Management Agent (UMA)
- Includes status LEDs

Ethernet Types Supported

- IEEE 802.3ab 1000Base-T twisted pair
- IEEE 802.3z 1000Base-X fiber
- IEEE 802.3x Flow Control
- IEEE 802.3i 10Base-T twisted pair
- IEEE 802.3u 100Base-TX twisted pair

Form Factor:

- Double-wide module

Regulatory Approvals

- FCC Class A • UL/cUL • CE • CSA

Fiber Types Supported

- SFP connector
- 1300 nm multi-mode ST or SC
- 1310 nm single-mode/PLUS ST or SC
- 1310 nm single-mode/LONG ST or SC
- 1550 nm single-mode/LONG SC
- Single-strand fiber
- Wavelengths (1270 - 1610 nm)

Connectors:

- RJ-45, ST or SC and LC (with SFP version)

Shipping Weight:

- 0.8 lbs (0.36 kg)

Environmental

- Humidity: 5% - 95% (non-condensing)
- Operating Temperature:
 - +32° to +122° F (0° to +50° C)
- Storage Temperature:
 - -13° to +158° F (-25° to +70° C)

Power Consumption:

- 580mA at 5V

Ordering Information

PART NUMBER	DESCRIPTION	DISTANCE
iMcV-Giga-FiberLinX-II SFP **		
856-14760	iMcV-Giga-FiberLinX-II, TX/SFP (uses one SFP/1250-ED SFPs)	1 Various
856-14761	iMcV-Giga-FiberLinX-II, SFP/SFP (uses two SFP/1250-ED SFPs)	1 Various
iMcV-Giga-FiberLinX-II 10/100/1000 Mbps		
856-14869	iMcV-Giga-FiberLinX-II, TX/SX-MM850-SC	220/550 m
856-14870	iMcV-Giga-FiberLinX-II, TX/LX-SM1310-SC	15 km
856-14871	iMcV-Giga-FiberLinX-II, TX/LX-SM1310/PLUS-SC	40 km
856-14872	iMcV-Giga-FiberLinX-II, TX/LX-SM1550/LONG-SC	80 km
856-14881	iMcV-Giga-FiberLinX-II, TX/LX-SM1550/XLONG-SC	100 km
iMcV-Giga-FiberLinX-II TX/SSFX Single-Strand Fiber *		
856-14873	iMcV-Giga-FiberLinX-II, TX/SSLX-SM1310-SC (1550 rcv)	15 km
856-14874	iMcV-Giga-FiberLinX-II, TX/SSLX-SM1550-SC (1310 rcv)	15 km
856-14890	iMcV-Giga-FiberLinX-II, TX/SSBX-SM1310-SC (1490 rcv)	10 km
856-14891	iMcV-Giga-FiberLinX-II, TX/SSBX-SM1490-SC (1310 rcv)	10 km
856-14892	iMcV-Giga-FiberLinX-II, TX/SSBX-SM1310/PLUS-SC (1490 rcv)	30 km
856-14893	iMcV-Giga-FiberLinX-II, TX/SSBX-SM1490/PLUS-SC (1310 rcv)	30 km
856-14875	iMcV-Giga-FiberLinX-II, TX/SSLX-SM1310/PLUS-SC (1550 rcv)	40 km
856-14876	iMcV-Giga-FiberLinX-II, TX/SSLX-SM1550/PLUS-SC (1310 rcv)	40 km
856-14877	iMcV-Giga-FiberLinX-II, TX/SSLX-SM1490/LONG-SC (1550 rcv)	70 km
856-14878	iMcV-Giga-FiberLinX-II, TX/SSLX-SM1550/LONG-SC (1490 rcv)	70 km
856-14879	iMcV-Giga-FiberLinX-II, TX/SSLX-SM1490/XLONG-SC (1550 rcv)	80 km
856-14880	iMcV-Giga-FiberLinX-II, TX/SSLX-SM1550/XLONG-SC (1490 rcv)	80 km

PART NUMBER	DESCRIPTION	DISTANCE
iMcV-Giga-FiberLinX-II CWDM Fiber		
856-14850	iMcV-Giga-FiberLinX-II, TX+FX-CWDM-SM1270-SC	40 km
856-14851	iMcV-Giga-FiberLinX-II, TX+FX-CWDM-SM1290-SC	40 km
856-14852	iMcV-Giga-FiberLinX-II, TX+FX-CWDM-SM1310-SC	40 km
856-14853	iMcV-Giga-FiberLinX-II, TX+FX-CWDM-SM1330-SC	40 km
856-14854	iMcV-Giga-FiberLinX-II, TX+FX-CWDM-SM1350-SC	40 km
856-14855	iMcV-Giga-FiberLinX-II, TX+FX-CWDM-SM1370-SC	40 km
856-14856	iMcV-Giga-FiberLinX-II, TX+FX-CWDM-SM1390-SC	40 km
856-14857	iMcV-Giga-FiberLinX-II, TX+FX-CWDM-SM1410-SC	40 km
856-14858	iMcV-Giga-FiberLinX-II, TX+FX-CWDM-SM1430-SC	40 km
856-14859	iMcV-Giga-FiberLinX-II, TX+FX-CWDM-SM1450-SC	70 km
856-14860	iMcV-Giga-FiberLinX-II, TX+FX-CWDM-SM1470-SC	70 km
856-14861	iMcV-Giga-FiberLinX-II, TX+FX-CWDM-SM1490-SC	70 km
856-14862	iMcV-Giga-FiberLinX-II, TX+FX-CWDM-SM1510-SC	70 km
856-14863	iMcV-Giga-FiberLinX-II, TX+FX-CWDM-SM1530-SC	70 km
856-14864	iMcV-Giga-FiberLinX-II, TX+FX-CWDM-SM1550-SC	70 km
856-14865	iMcV-Giga-FiberLinX-II, TX+FX-CWDM-SM1570-SC	70 km
856-14866	iMcV-Giga-FiberLinX-II, TX+FX-CWDM-SM1590-SC	70 km
856-14867	iMcV-Giga-FiberLinX-II, TX+FX-CWDM-SM1610-SC	70 km

* These products have single-strand fiber technology Deploy in pairs, or connect to another compatible B&B Electronics single-strand fiber product.

** SFP modules are sold separately.



www.bb-elec.com orders@bb-elec.com support@bb-elec.com
International Office: 707 Dayton Road PO Box 1040 Ottawa, IL 61350 USA 815-433-5100 Fax 815-433-5104
California Office: 25531 Commercentre Dr. #210 Lake Forest, Ca. 92630 USA 949-465-3000 Fax 949-465-3020
European Office: Westlink Commercial Park Oranmore Co. Galway Ireland +353 91 792444 Fax +353 91 792445

Mouser Electronics

Authorized Distributor

Click to View Pricing, Inventory, Delivery & Lifecycle Information:

B&B Electronics:

[856-14863](#) [856-14891](#) [856-14853](#) [856-14860](#) [856-14874](#) [856-14857](#) [856-14850](#) [856-14893](#) [856-14873](#) [856-14761](#) [856-14877](#) [856-14859](#) [856-14870](#) [856-14866](#) [856-14869](#) [856-14760](#) [856-14881](#) [856-14852](#) [856-14854](#) [856-14864](#) [856-14875](#) [856-14878](#) [856-14892](#) [856-14851](#) [856-14855](#) [856-14862](#) [856-14871](#) [856-14890](#) [856-14856](#) [856-14858](#) [856-14876](#) [856-14865](#) [856-14867](#) [856-14861](#) [856-14872](#)