

## ***CDB5343: Evaluation Board for CS5343***

### **Features**

- ◆ Demonstrates Recommended Layout and Grounding Arrangements
- ◆ CS8406 Generates S/PDIF and EIAJ-340-Compatible Digital Audio
- ◆ Requires Only an Analog Signal Source and Power Supply for a Complete Analog-to-Digital Converter System

### **Description**

The CDB5343 evaluation board is an excellent means for quickly evaluating the CS5343 24-bit, stereo A/D converter. Evaluation requires a digital signal analyzer, an analog source, and a power supply.

Also included is an CS8406 digital audio interface transmitter that generates S/PDIF and EIAJ-340-compatible audio data. The digital audio data is available via RCA phone and optical connectors.

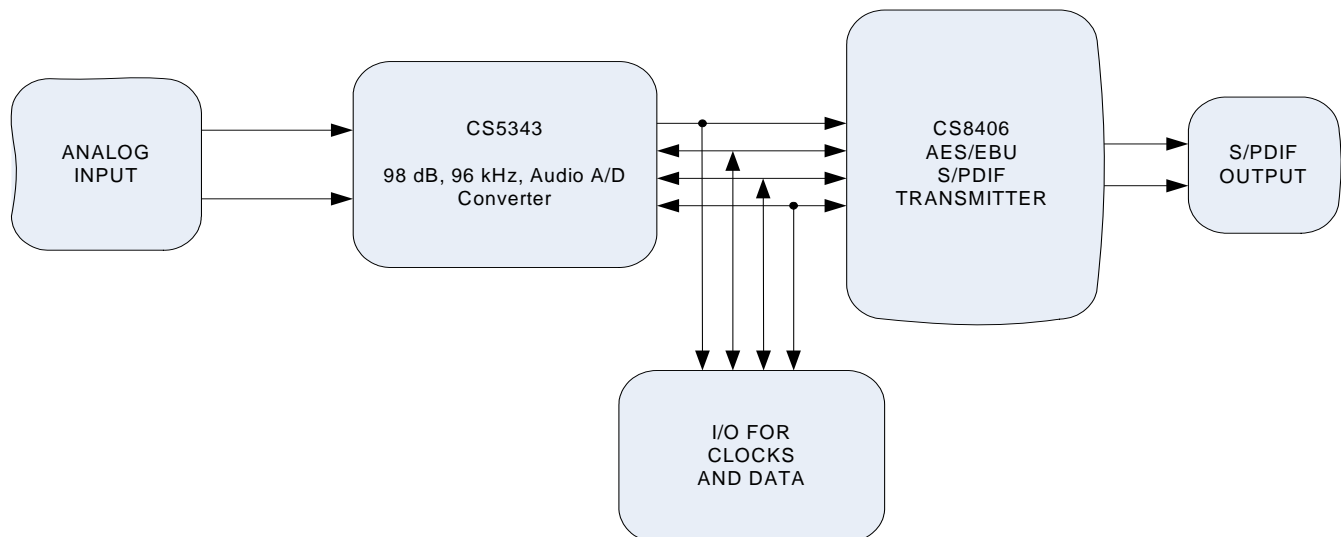

---

**TABLE OF CONTENTS**

<b>1. SYSTEM OVERVIEW .....</b>	<b>4</b>
1.1 CS5343 .....	4
<b>2. CS8406 DIGITAL AUDIO TRANSMITTER .....</b>	<b>4</b>
<b>3. CRYSTAL OSCILLATOR .....</b>	<b>4</b>
<b>4. CLOCK &amp; DATA I/O HEADER .....</b>	<b>4</b>
4.1 Clock & Data Routing .....	4
4.1.1 MCLK Source .....	4
4.1.2 Sub-Clock Source .....	4
4.1.3 Data Routing .....	5
<b>5. POWER .....</b>	<b>5</b>
<b>6. GROUNDING AND POWER SUPPLY DECOUPLING .....</b>	<b>5</b>
<b>7. ANALOG INPUT .....</b>	<b>5</b>
<b>8. CONNECTORS .....</b>	<b>6</b>
<b>9. JUMPER AND SWITCH SETTINGS .....</b>	<b>6</b>
9.1 Jumper J4 .....	6
9.2 Switch S1 .....	6
9.2.1 CS5343 .....	6
9.2.2 CS8406 .....	7
9.2.3 MCLK .....	7
9.2.4 SCLK, LRCK .....	7
9.2.5 SPEED .....	7
9.2.6 MCLK/LRCK Ratio .....	7
<b>10. RESET .....</b>	<b>8</b>
<b>11. EVALUATING THE CS5344 .....</b>	<b>8</b>
<b>12. PERFORMANCE PLOTS .....</b>	<b>9</b>
<b>13. CDB PERFORMANCE CURVES .....</b>	<b>12</b>
13.1 Total Harmonic Distortion + Noise (THD+N) .....	12
13.2 FFTIm .....	13
<b>14. CDB SCHEMATICS .....</b>	<b>14</b>
<b>15. CDB LAYOUT .....</b>	<b>20</b>
<b>16. REVISION HISTORY .....</b>	<b>23</b>

**LIST OF FIGURES**

Figure 1. FFT (-1 dB 48 kHz) .....	9
Figure 2. FFT (-60 dB, 48 kHz) .....	9
Figure 3. FFT (48 kHz, No Input) .....	9
Figure 4. 48 kHz, THD+N vs. Input Freq .....	9
Figure 5. 48 kHz, THD+N vs. Level .....	9
Figure 6. 48 kHz, Fade-to-Noise Linearity .....	9
Figure 7. 48 kHz, Frequency Response .....	10
Figure 8. 48 kHz, Crosstalk .....	10
Figure 9. FFT (-1 dB 96 kHz) .....	10
Figure 10. FFT (-60 dB, 96 kHz) .....	10
Figure 11. FFT (96 kHz, No Input) .....	10
Figure 12. 96 kHz, THD+N vs. Input Freq .....	10
Figure 13. 96 kHz, THD+N vs. Level .....	11
Figure 14. 96 kHz, Fade-to-Noise Linearity .....	11
Figure 15. 96 kHz, Frequency Response .....	11
Figure 16. 96 kHz, Crosstalk .....	11
Figure 17. CDB5343 THD+N Performance .....	12
Figure 18. FFT from CDB5343 Output .....	13
Figure 19. CDB Block Diagram .....	14
Figure 20. CS5343 Analog-to-Digital Converter .....	15
Figure 21. Analog Input .....	16
Figure 22. Switches, Crystal Oscillator, and Clock Routing .....	17
Figure 23. CS8406 S/PDIF Transmitter .....	18
Figure 24. Power .....	19
Figure 25. CDB Silk-Screen .....	20
Figure 26. Topside Layer .....	21
Figure 27. Bottomside Layer .....	22

**LIST OF TABLES**

Table 1. System Connections .....	6
Table 2. CDB5343 S1 Settings .....	6

## 1. SYSTEM OVERVIEW

The CDB5343 evaluation board is an excellent tool for evaluating the CS5343 Analog-to-Digital Converter (ADC). A minimum number of passive components condition the analog input signal prior to the CS5343, and the on-board CS8406 digital audio interface transmitter provides an easy interface to digital audio signal analyzers including the majority of digital audio test equipment. Additionally, the CDB5343 features an interface header (J3) for clock and data I/O.

Figures 19 through Figures 27 show the CDB5343 schematic and layout.

### 1.1 CS5343

The CS5343 ADC performs stereo 24-bit A/D conversion at sample rates of up to 108 kHz and generates I<sup>2</sup>S audio format data. Furthermore, in both Master and Slave Modes the CS5343 supports MCLK/LRCK ratios of 256x and 384x. The CS5343 product datasheet contains complete device information.

## 2. CS8406 DIGITAL AUDIO TRANSMITTER

The CS8406 converts the CS5343 output to a standard S/PDIF data stream. Given an MCLK/LRCK ratio equal to 256x, the CS8406 can operate as clock master or clock slave, but the CS8406 cannot be used with an MCLK/LRCK ratio of 384x on this board. Moreover, by default on this board, the CS8406 accepts only I<sup>2</sup>S audio format; however, [Section 11. on page 8](#) describes the procedure of configuring the device for Left-Justified audio format. See the CS8406 data sheet for complete device information.

## 3. CRYSTAL OSCILLATOR

Oscillator Y1 provides an on-board system master clock. The oscillator is mounted in pin sockets, allowing for easy removal or replacement. The board includes a 12.288 MHz crystal oscillator populated at Y1.

## 4. CLOCK & DATA I/O HEADER

Header J3 makes interfacing to external systems easy. MCLK direction is controlled by switch S1, as is the direction of the sub-clocks, SCLK and LRCK. The header pins associated with MCLK, SCLK, and LRCK can accept 3.3 V or 5 V input signals, but are fixed at 3.3 V when set as outputs. SDOUT is always a 3.3 V output.

### 4.1 Clock & Data Routing

The user can configure the source and destinations of the clocks required to support the operation of the CS5343. [Section 4.1.1](#) through [Section 4.1.3](#) discuss valid configurations.

#### 4.1.1 MCLK Source

The CS5343 and CS8406 must receive a Master Clock. MCLK can come from either the crystal oscillator installed at Y1 or via header J3. Header J3 can accept a 3.3 V or 5 V logic-level MCLK when configured as an input, but will output MCLK only at 3.3 V when configured as an output.

#### 4.1.2 Sub-Clock Source

SCLK and LRCK comprise the system sub-clocks and must be either provided to, or generated by, the CS5343.

The CS5343 generates sub-clocks when it is set for Master Mode via DIP switch S1. In this scenario, the CS8406 should be set to Slave Mode to receive sub-clocks. Similarly, the “SCLK, LRCK” switch should be closed to direct sub-clocks to the header. The sub-clock output of the J3 header is fixed at 3.3 V.

If the user configures the CS5343 for Slave Mode, the device must receive sub-clocks either from the CS8406 or from an external source via header J3. If the CS8406 is the intended sub-clock source, DIP switch S1 must be set such that the CS8406 is in Master Mode and “SCLK, LRCK” are routed to the header. If both the CS5343 and the CS8406 are set to Slave Mode, DIP switch S1 must indicate that the sub-clocks come “FROM HDR.” Sub-clock input to header J3 may be either 3.3 V or 5 V.

### 4.1.3 Data Routing

Audio data from the CS5343 SDOOUT pin is routed to header J3 and the CS8406. The SDOOUT pin of J3 is always a 3.3 V output. The CS5343 produces data in only I<sup>2</sup>S audio format; therefore the data capture device should be set accordingly.

The CS8406 accepts data in I<sup>2</sup>S audio format, which it converts to S/PDIF and EIAJ-340-compatible data. This data is available for capture from either the optical connector (J9) or the RCA jack (J6).

## 5. POWER

Power must be supplied to the evaluation board through the +5 V binding post (J2). The +5 V input must be referenced to the single black binding post ground connector (J1).

**WARNING:** Please refer to the CS5343 data sheet for allowable voltage levels.

## 6. GROUNDING AND POWER SUPPLY DECOUPLING

To optimize performance, PCB designs supporting the CS5343 require careful attention to power supply, grounding, and signal routing. [Figures 26](#) and [27](#) show the basic component/signal interconnect for the CDB5343, and [Figure 25](#) shows the component placement. These figures demonstrate the optimal layout of components used to support the CS5343. For example, these figures show that the decoupling capacitors are located as close to the CS5343 as possible. The layout also shows extensive use of ground plane fill which greatly reduces radiated noise.

## 7. ANALOG INPUT

The user can input single-ended analog signals via the RCA connectors, J5 and J7. A 2 V<sub>rms</sub> single-ended signal into the RCA connectors will drive the CS5343 inputs to full scale (1 V<sub>rms</sub> for V<sub>A</sub> = 5 V). The input network on the CDB5343 was designed to demonstrate that the CS5343 will achieve full performance with a source impedance up to 2.5 k $\Omega$  (looking back from the CS5343 inputs) while allowing for 2 V<sub>rms</sub> inputs. Another advantage of this circuit is that it provides an input impedance of 10 k $\Omega$ , similar to many commercial audio products.

## 8. CONNECTORS

Table 1 lists the connectors on the CDB5343, the reference designator of each connector, the directionality, and the associated signal.

CONNECTOR	REFERENCE DESIGNATOR	INPUT/OUTPUT	SIGNAL
+5V	J2	INPUT	+5 V power to crystal oscillator and DC voltage regulator
GND	J1	INPUT	Ground connection from the power supply
AINR	J7	INPUT	Analog input right channel
AINL	J5	INPUT	Analog input left channel
Co-axial	J6	OUTPUT	Digital audio (S/PDIF) output
Optical	J9	OUTPUT	Digital audio (S/PDIF) output
I/O HDR	J3	INPUT/OUTPUT	Master Clock, Serial Clock, Left/Right Clock, SDOUT

Table 1. System Connections

## 9. JUMPER AND SWITCH SETTINGS

The user can fully configure the CDB5343 with a bank of six DIP switches (S1) and a single jumper setting on header J4.

### 9.1 Jumper J4

This jumper selects the magnitude of VA, either 3.3 V or 5 V. The CS5343 is a single-supply device; therefore the magnitude of VA affects the full-scale analog input voltage as well as the digital I/O voltage. Digital I/O is always fixed at VA, and the full-scale input is nominally 0.56xVA Vpp, as specified in the CS5343 data sheet. If the user selects 5 V, the CS5343 full-scale analog input voltage is 2.82 Vpp (1 Vrms) and the digital I/O is set to 5 V. If 3.3 V is selected, the full-scale analog input voltage is 1.86 Vpp (660 mVrms) and digital I/O is 3.3 V.

### 9.2 Switch S1

Table 2 shows the available settings for S1 with the default settings.

	OPEN	CLOSED
CS5343	MASTER (default)	SLAVE
CS8406	MASTER	SLAVE (default)
MCLK	FROM HDR	TO HDR (default)
SCLK, LRCK	FROM HDR	TO HDR (default)
SPEED	DSM	SSM (default)
MCLK/LRCK	256x (default)	384x

Table 2. CDB5343 S1 Settings

#### 9.2.1 CS5343

This switch configures the CS5343 for either Master Mode or Slave Mode operation. When set as clock Master, the CS8406 must be set to “Slave” and “SCLK, LRCK” must be set to “TO HDR.” When CS5343 is configured for Slave Mode, the CS8406 must be set for Master Mode, or “SCLK, LRCK” must be set to “FROM HDR.”

Changing the state of this switch while the device is running will have no effect on the CS5343 as it must be reset to detect the change. Reset is accomplished by removing and restoring power to the device. Alternatively, removing and restoring MCLK will initiate a reset of the digital section, which is also sufficient for the CS5343 to detect a change in mode settings.

### 9.2.2 CS8406

This switch sets the CS8406 for either Master Mode or Slave Mode. In Master Mode, the CS5343 must be configured as a clock slave and “SCLK, LRCK” set to “TO HDR.” In Slave Mode, either the CS5343 can be set to Master Mode or the user can set the “SCLK, LRCK” switch to “FROM HDR.”

### 9.2.3 MCLK

MCLK can either come from the header, as selected by “FROM HDR,” or from the on-board crystal oscillator (Y1) as selected by “TO HDR.”

### 9.2.4 SCLK, LRCK

The sub-clocks, SCLK and LRCK, are either produced on board by the CS5343 or the CS8406 or produced externally. If generated by an external device, this switch must be set to “FROM HDR.” If the CS5343 or CS8406 generate the sub-clocks, this switch must be set to “FROM HDR.”

### 9.2.5 SPEED

The CS5343 can operate in Single-Speed Mode (SSM) or Double-Speed Mode (DSM) as described in the CS5343 product datasheet.

In Master Mode, the CS5343 defaults to SSM based on an internal 100 k $\Omega$  pull-up resistor from the LRCK pin to VA. Setting the “SPEED” switch to “DSM” will place a 10 k $\Omega$  pull-down resistor between LRCK and GND to select Double-Speed Mode. Because the CS5343 determines its Master Mode speed based on start-up options, the speed mode cannot be toggled during operation. To change the speed in Master Mode, the device must be reset by removing and restoring power or removing and restoring MCLK.

This switch also configures the MCLK/LRCK ratio for the CS8406. Selecting SSM configures the CS8406 for a 512x MCLK/LRCK ratio while DSM sets an MCLK/LRCK ratio of 256x. In this design, the CS8406 cannot support of a 384x MCLK/LRCK ratio.

### 9.2.6 MCLK/LRCK Ratio

This switch will configure the CS5343 for either a 256x MCLK/LRCK ratio or a 384x MCLK/LRCK ratio in Master Mode. In Slave Mode the CS5343 auto-detects the MCLK/LRCK ratio; therefore this configuration step is unnecessary in Slave Mode. In Master Mode, selection of this parameter is performed via a start-up option. An internal 100 k $\Omega$  pull-up resistor from the SCLK pin to VA will select 256x by default. An external 10 k $\Omega$  pull-down resistor from the SCLK pin to GND will select an MCLK/LRCK ratio of 384x.

Typical applications that use a 384x MCLK/LRCK ratio derive a 48 kHz LRCK from a 18.384 MHz MCLK. Deriving MCLK from the included 12.288 MHz crystal oscillator will result in a sample rate of 32 kHz.

The CS8406 is not configured to support a 384x MCLK/LRCK ratio in this design; therefore analysis in this mode must be performed by retrieving data through the interface header (J3).

## 10.RESET

The CS5343 features Power-On Reset which means that performing a full reset of the CS5343 requires a power-cycling the device. On the CDB5343, this can be accomplished with by removing and restoring the power-supply or by removing and restoring the jumper on J3. Alternatively, removing and restoring MCLK to the device will effect a reset of just the digital portion of the device. The device enters Power-Down Mode when MCLK is removed and draws less current.

## 11.EVALUATING THE CS5344

The CDB5343 comes with only the CS5343 ADC installed, but some users may want to evaluate the pin-compatible CS5344 ADC. The two devices perform equivalently, but the CS5344 produces only Left-Justified audio format data; whereas the CS5343 creates only I<sup>2</sup>S audio format data. By following the four easy steps listed below, the user can modify the CDB5343 to accommodate the CS5344.

- *Step 1:* Remove CS5343 populated at U6
- *Step 2:* Install CS5344 at U6
- *Step 3:* Remove 0  $\Omega$  resistor populated at R36 (this resistor selects I<sup>2</sup>S Audio Format for the CS8406)
- *Step 4:* Install 0  $\Omega$  resistor at R43 (this resistor selects LJ Audio Format for the CS8406)

## 12.PERFORMANCE PLOTS

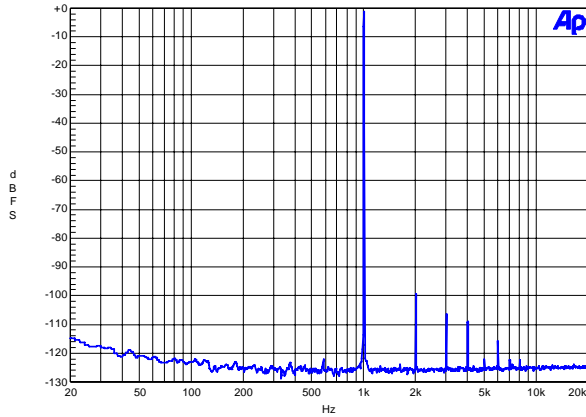

Figure 1. FFT (-1 dB 48 kHz)

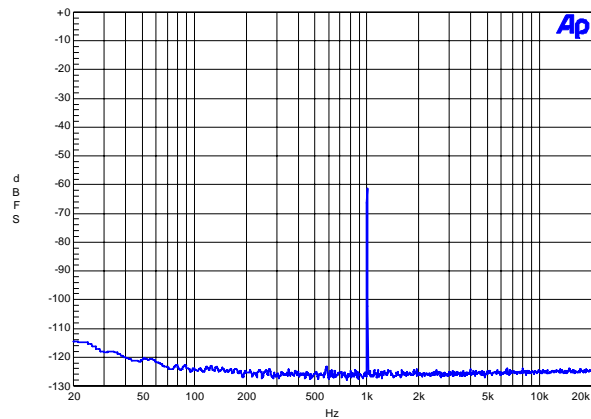

Figure 2. FFT (-60 dB, 48 kHz)

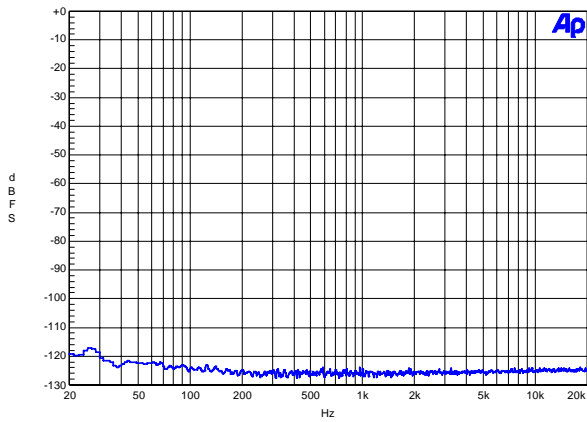

Figure 3. FFT (48 kHz, No Input)

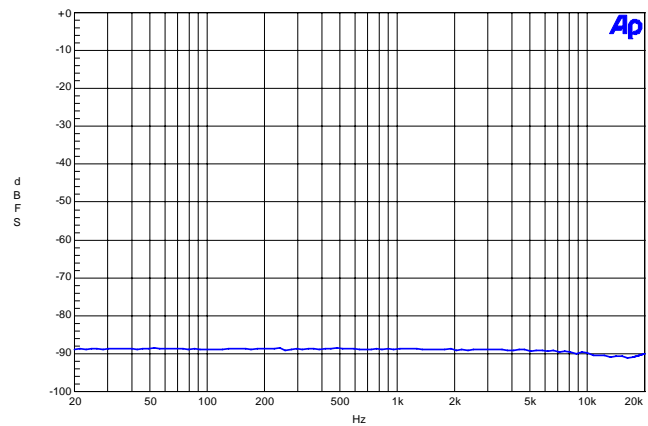

Figure 4. 48 kHz, THD+N vs. Input Freq

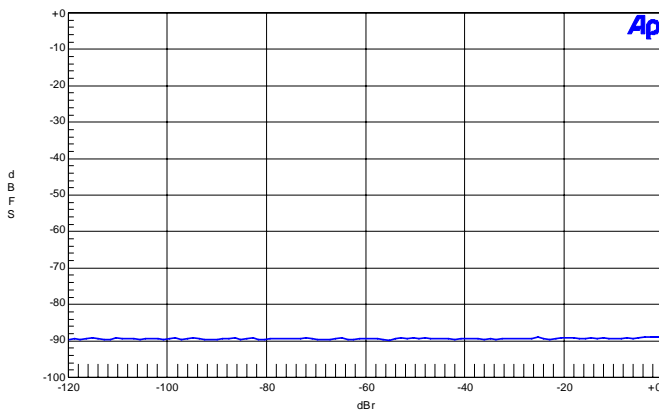
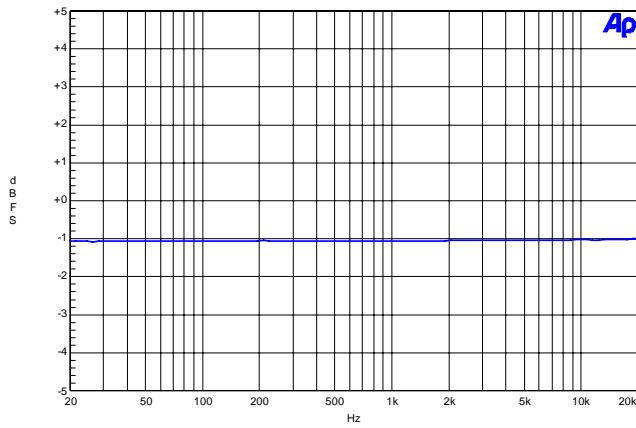
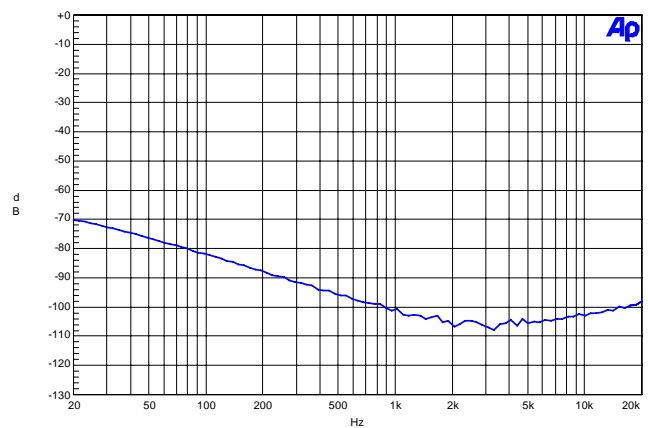
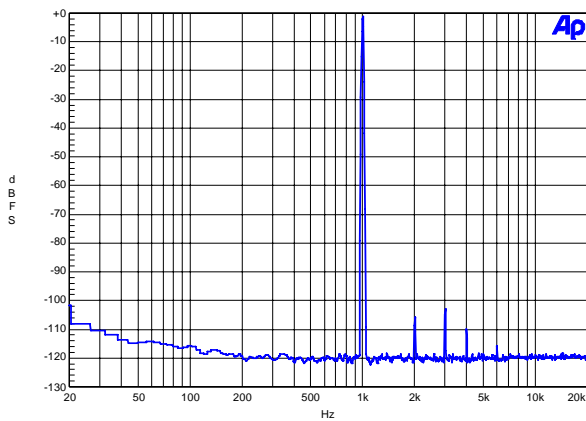
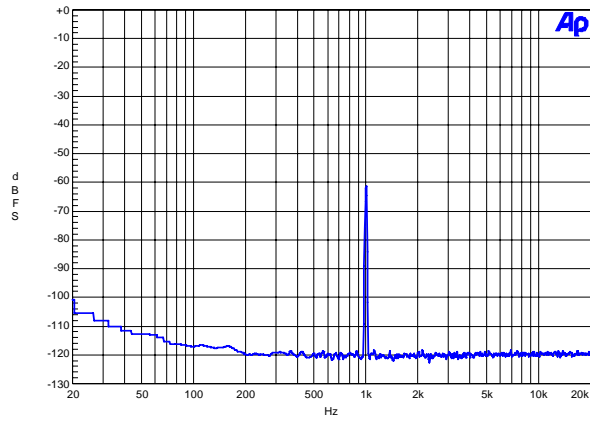
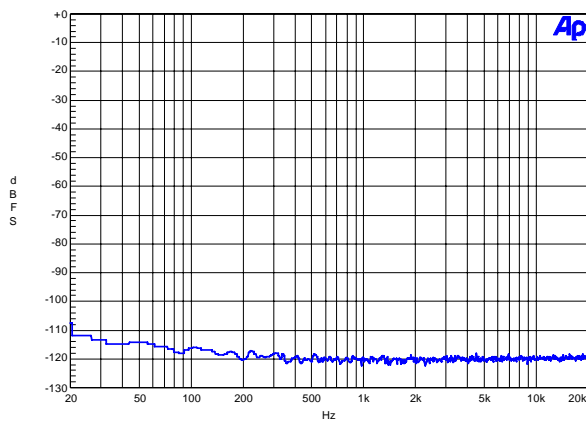
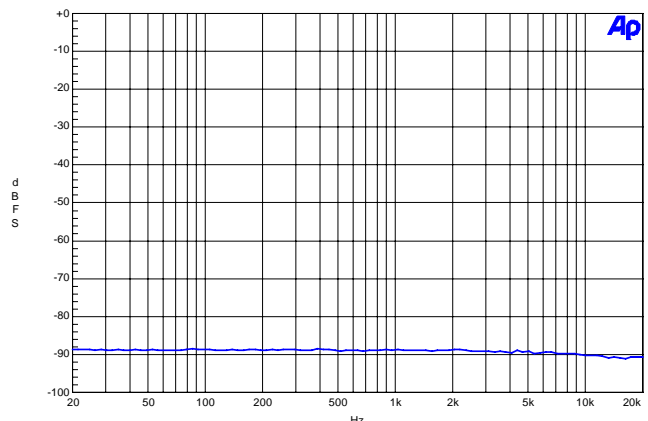
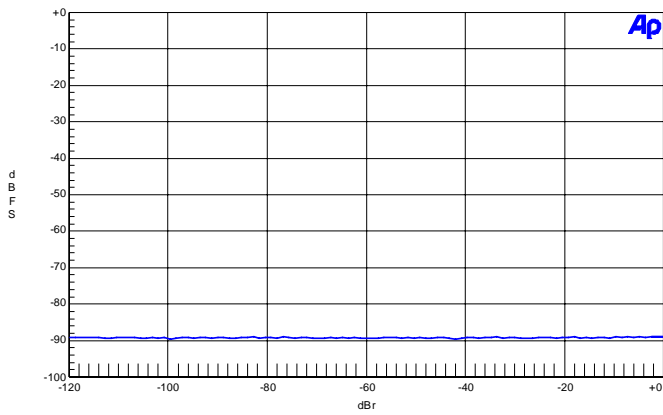

Figure 5. 48 kHz, THD+N vs. Level



Figure 6. 48 kHz, Fade-to-Noise Linearity

**Figure 7. 48 kHz, Frequency Response**

**Figure 8. 48 kHz, Crosstalk**

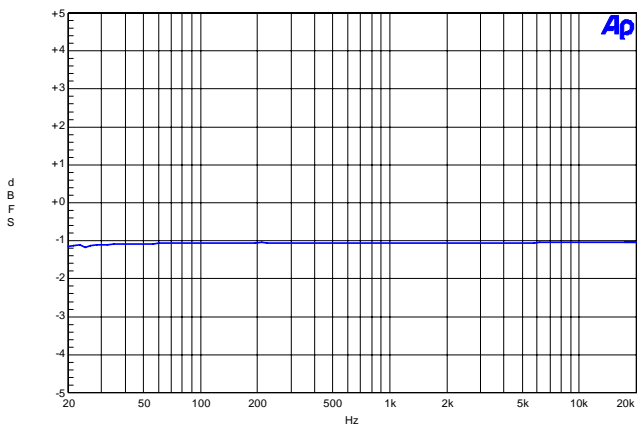
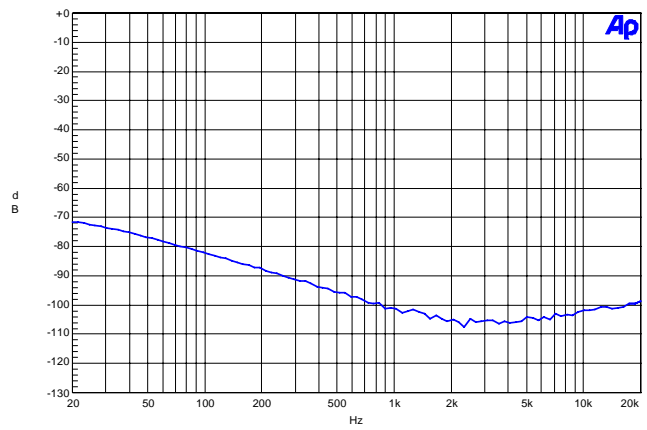
**Figure 9. FFT (-1 dB, 96 kHz)**

**Figure 10. FFT (-60 dB, 96 kHz)**

**Figure 11. FFT (96 kHz, No Input)**

**Figure 12. 96 kHz, THD+N vs. Input Freq**

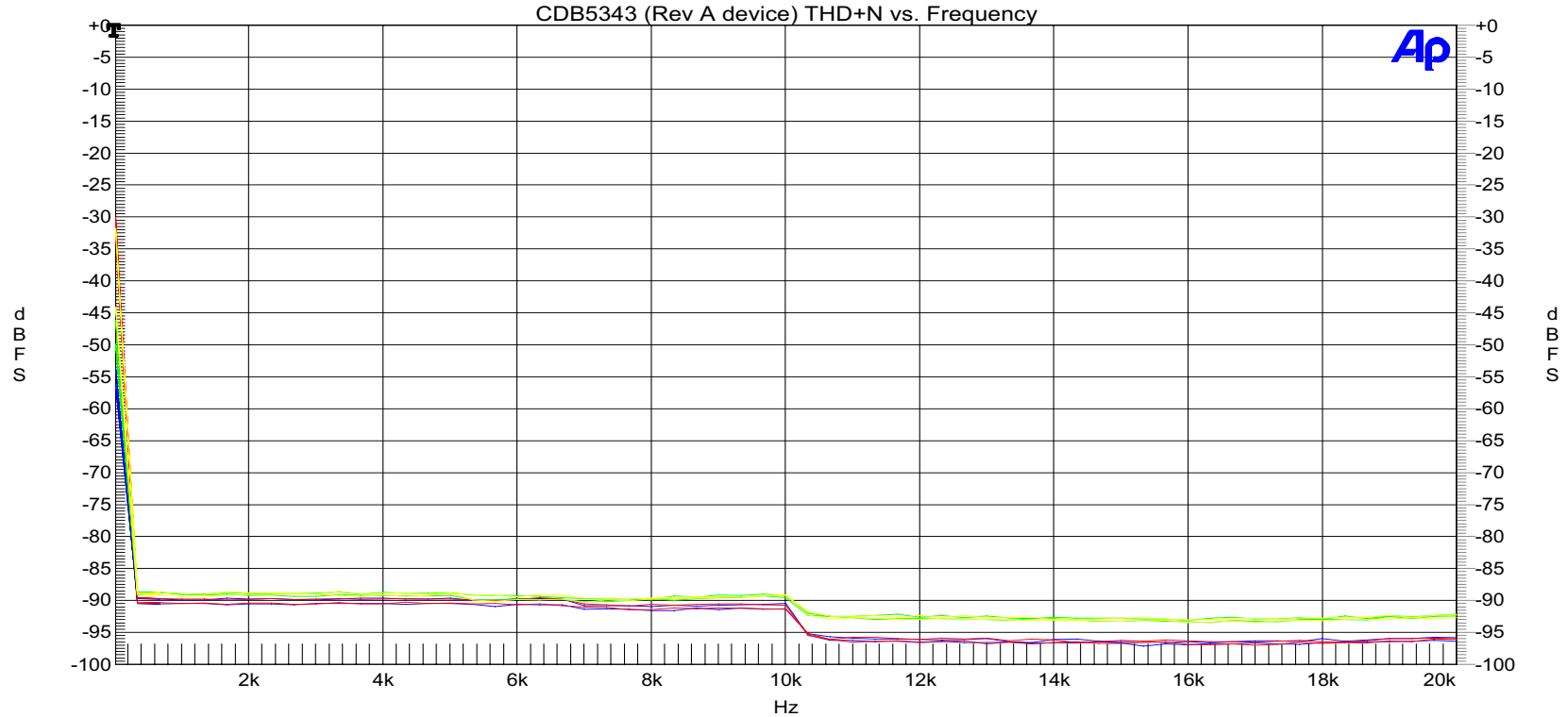

**Figure 13. 96 kHz, THD+N vs. Level**

**Figure 14. 96 kHz, Fade-to-Noise Linearity**

**Figure 15. 96 kHz, Frequency Response**

**Figure 16. 96 kHz, Crosstalk**

# 13.CDB PERFORMANCE CURVES

## 13.1 Total Harmonic Distortion + Noise (THD+N)

Figure 17 shows typical THD+N performance of the CS5343 installed on the CDB5343. Performance curves are displayed for each channel with the CS5343 running at Single-Speed in both Master and Slave Modes and for VA voltages of both +3.3 V and 5 V.



Sweep	Trace	Color	Line Style	Thick	Data	Axis	Comment
1	1	Blue	Solid	1	DSP Anlr.TH+D+N Ampl A	Left	5V Master SSM 256x
1	2	Blue	Solid	1	DSP Anlr.TH+D+N Ampl B	Right	5V Master SSM 256x
2	1	Red	Solid	1	DSP Anlr.TH+D+N Ampl A	Left	5V Slave SSM 256x
2	2	Red	Solid	1	DSP Anlr.TH+D+N Ampl B	Right	5V Slave SSM 256x
3	1	Green	Solid	1	DSP Anlr.TH+D+N Ampl A	Left	3.3 V Slave SSM 256x
3	2	Green	Solid	1	DSP Anlr.TH+D+N Ampl B	Right	3.3 V Slave SSM 256x
4	1	Yellow	Solid	1	DSP Anlr.TH+D+N Ampl A	Left	3.3 V Slave SSM 256x
4	2	Yellow	Solid	1	DSP Anlr.TH+D+N Ampl B	Right	3.3 V Slave SSM 256x

Figure 17. CDB5343 THD+N Performance



CIRUS LOGIC

CDB5343

### 13.2 FFTIm

Figure 18 shows a typical FFT of the output from the CS5343 on the CDB5343 with a 2 Vrms, 1 kHz sinewave input. For this plot, the device was configured for Single-Speed Mode with VA = 5 V.

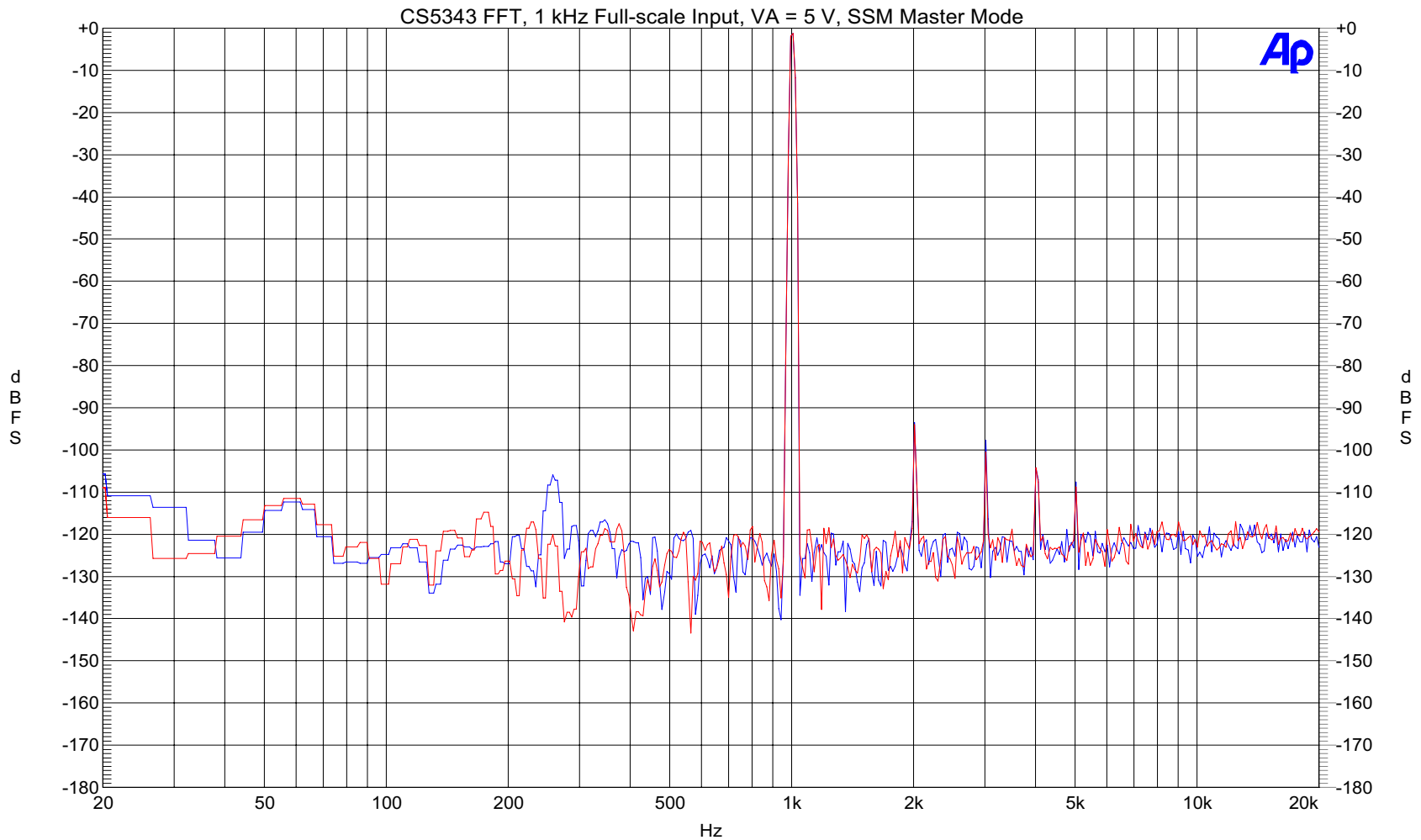

Sweep	Trace	Color	Line Style	Thick	Data	Axis	Comment
1	1	Blue	Solid	1	Fft.Ch.1 Ampl	Left	
1	2	Red	Solid	1	Fft.Ch.2 Ampl	Right	

Figure 18. FFT from CDB5343 Output

# 14.CDB SCHEMATICS

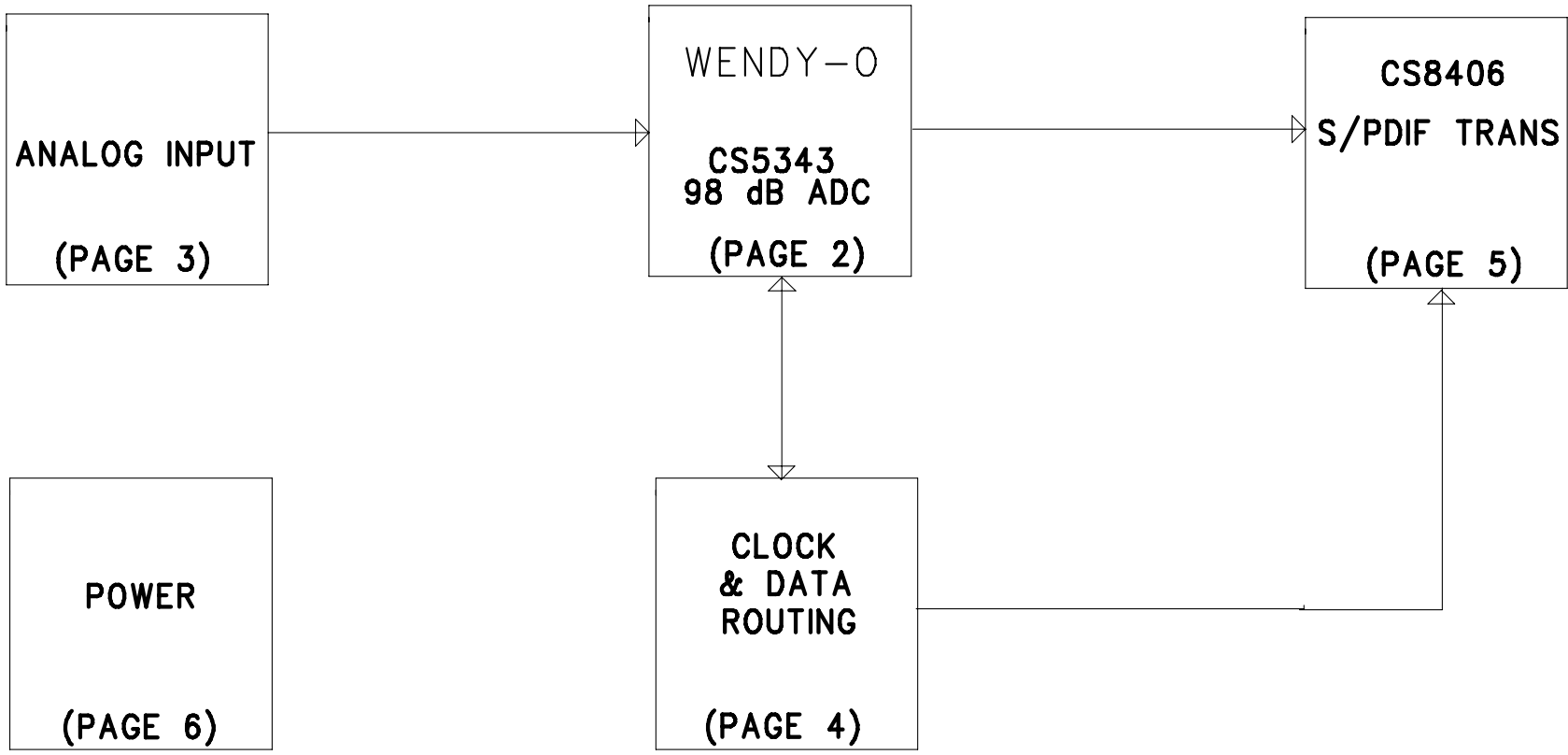
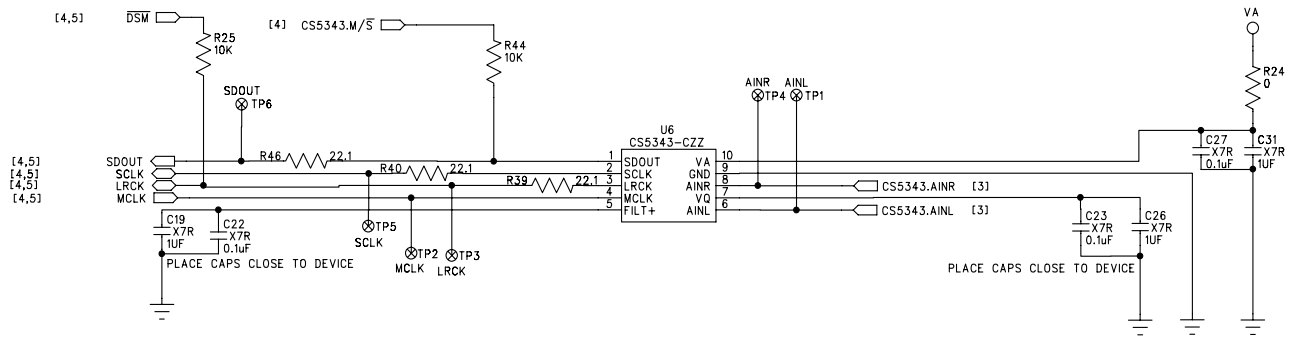
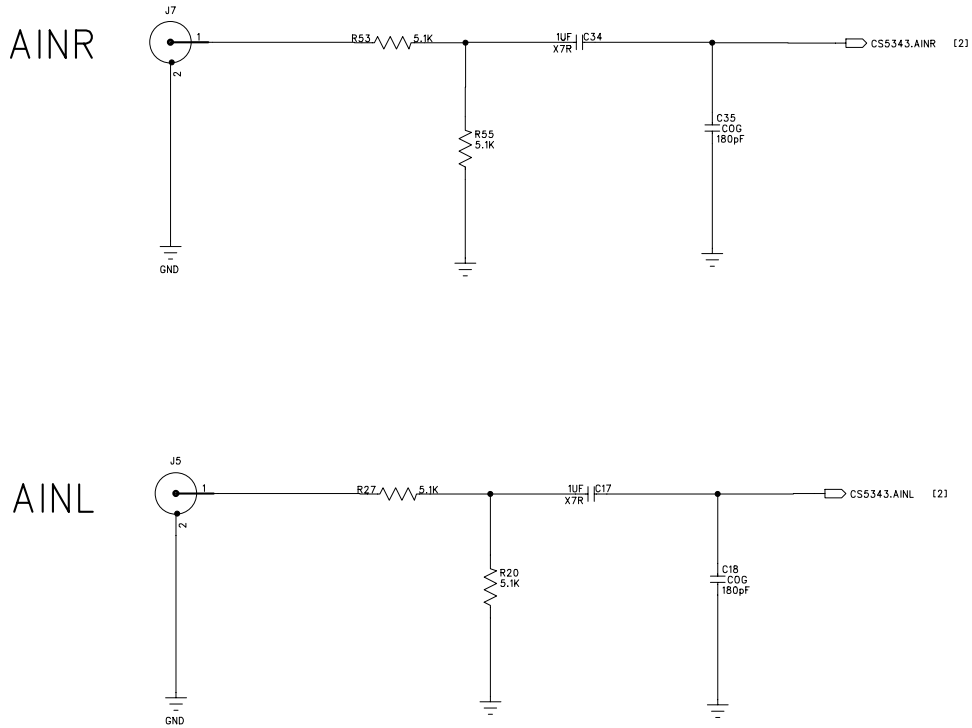

Figure 19. CDB Block Diagram



CS5343 96 kHz STEREO CODEC

Figure 20. CS5343 Analog-to-Digital Converter



### PASSIVE ANALOG INPUT

Figure 21. Analog Input

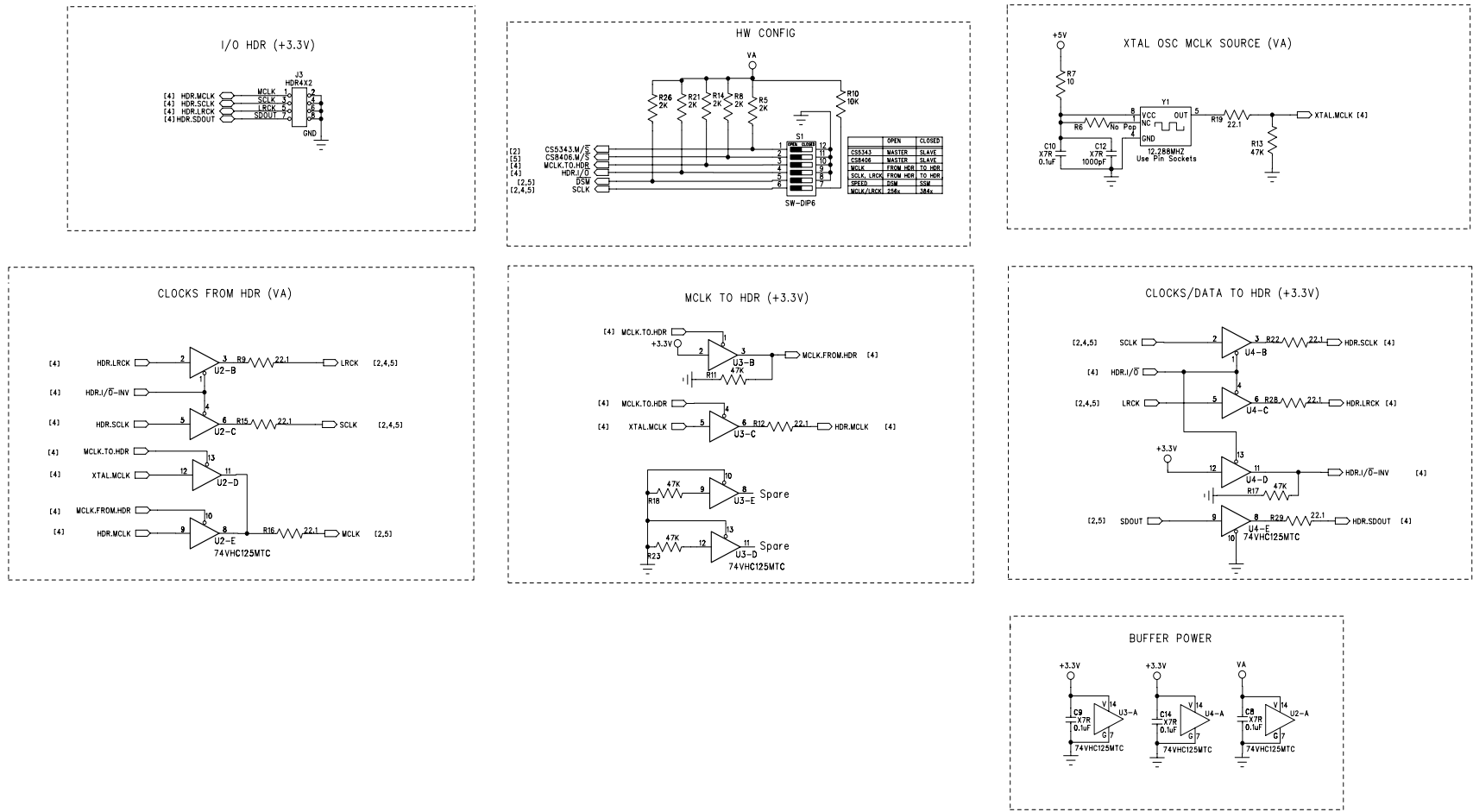
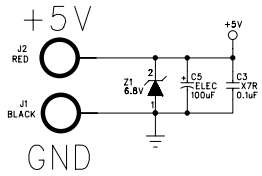

Figure 22. Switches, Crystal Oscillator, and Clock Routing



POWER CONN



VA SELECT

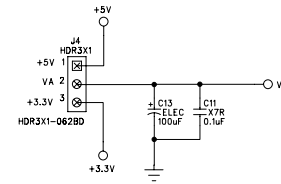

REGULATOR

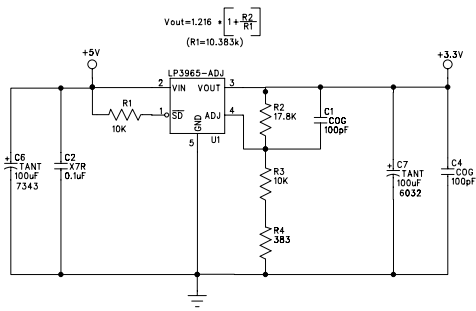

HARDWARE

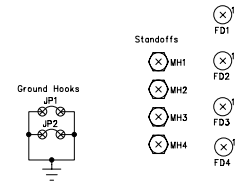

Figure 24. Power



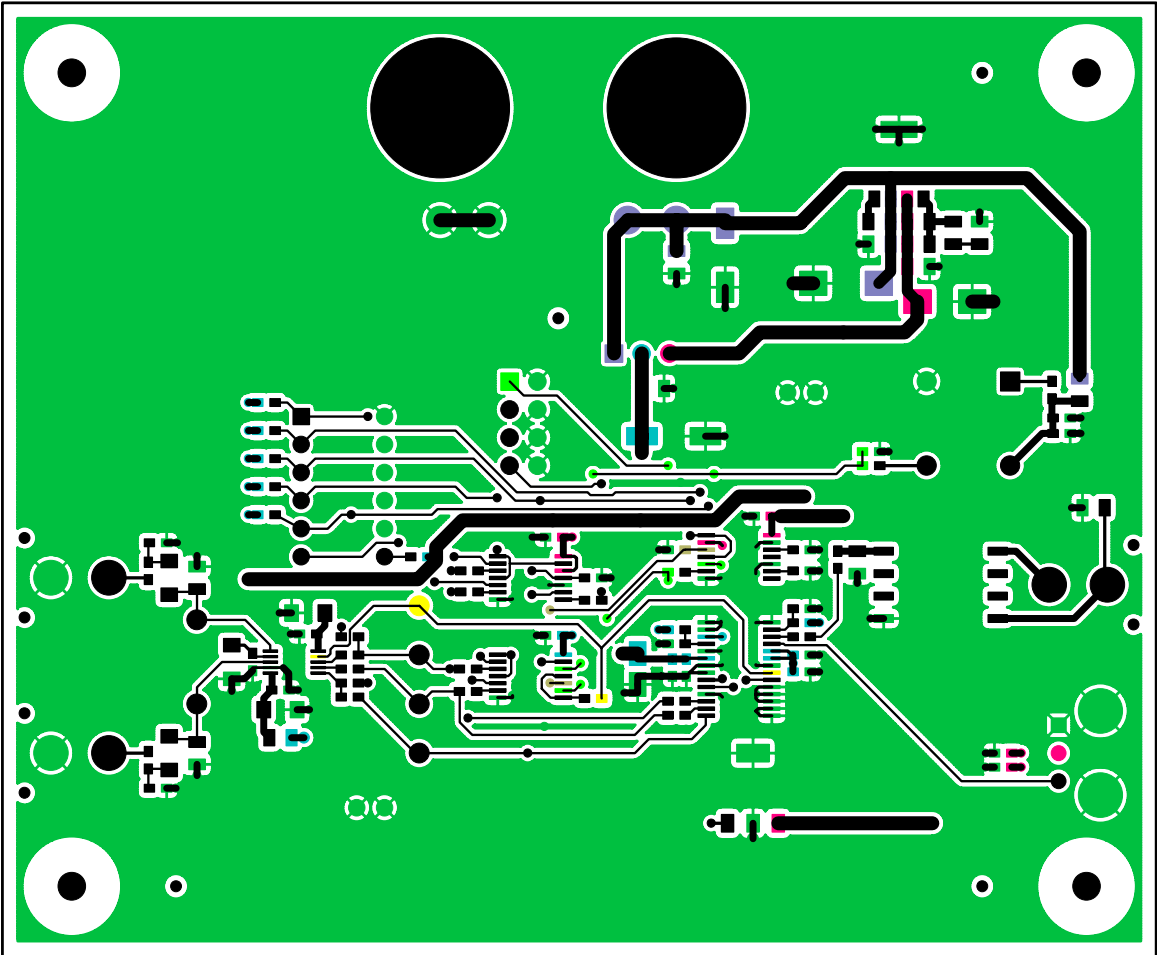

Figure 26. Topside Layer

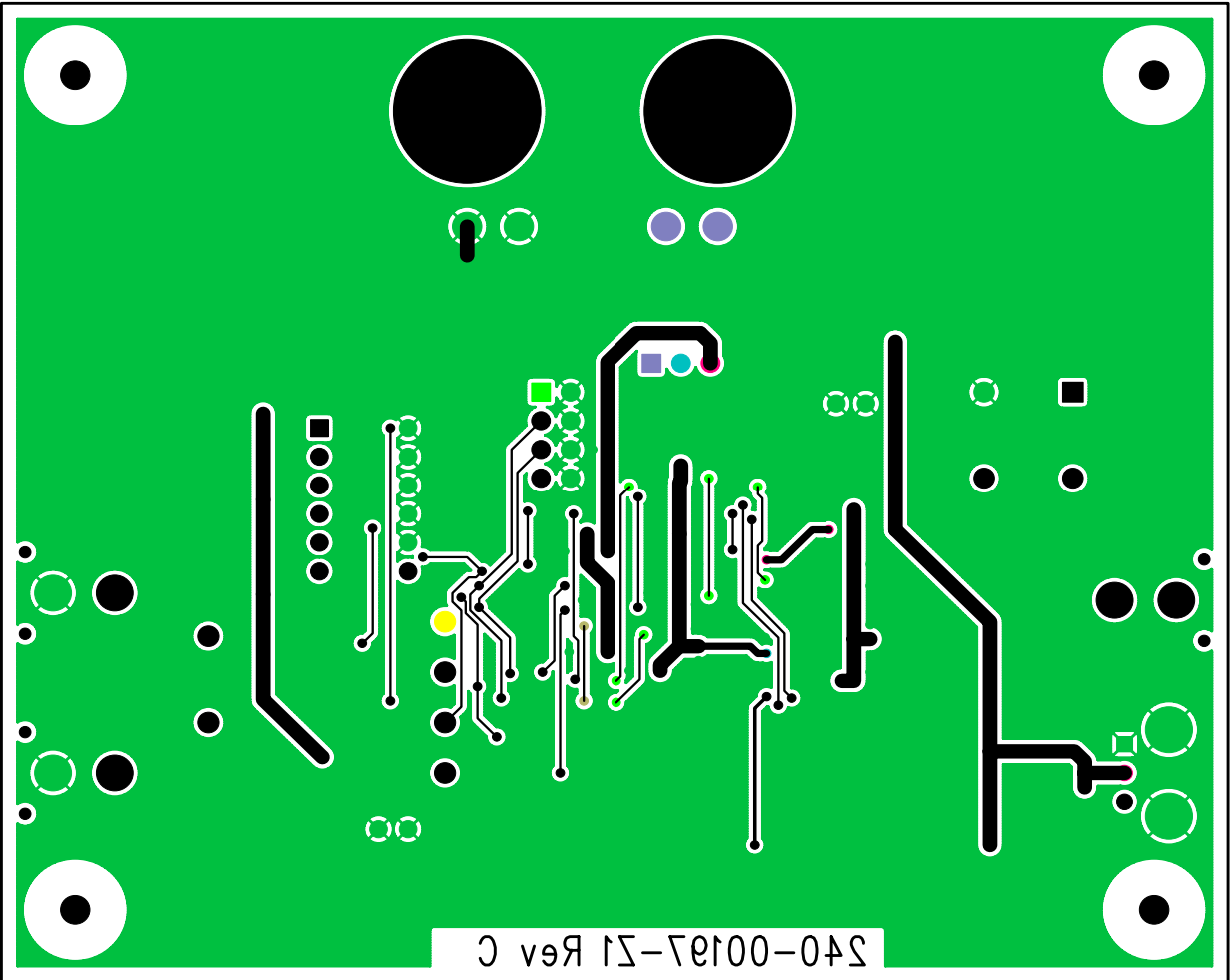

Figure 27. Bottomside Layer

---

## 16. REVISION HISTORY

Release	Changes
DB1	Initial Release
DB2	Added Performance Plots

---

### Contacting Cirrus Logic Support

For all product questions and inquiries, contact a Cirrus Logic Sales Representative.

To find the one nearest you, go to [www.cirrus.com](http://www.cirrus.com).

---

#### IMPORTANT NOTICE

Cirrus Logic, Inc. and its subsidiaries ("Cirrus") believe that the information contained in this document is accurate and reliable. However, the information is subject to change without notice and is provided "AS IS" without warranty of any kind (express or implied). Customers are advised to obtain the latest version of relevant information to verify, before placing orders, that information being relied on is current and complete. All products are sold subject to the terms and conditions of sale supplied at the time of order acknowledgment, including those pertaining to warranty, indemnification, and limitation of liability. No responsibility is assumed by Cirrus for the use of this information, including use of this information as the basis for manufacture or sale of any items, or for infringement of patents or other rights of third parties. This document is the property of Cirrus and by furnishing this information, Cirrus grants no license, express or implied under any patents, mask work rights, copyrights, trademarks, trade secrets or other intellectual property rights. Cirrus owns the copyrights associated with the information contained herein and gives consent for copies to be made of the information only for use within your organization with respect to Cirrus integrated circuits or other products of Cirrus. This consent does not extend to other copying such as copying for general distribution, advertising or promotional purposes, or for creating any work for resale.

CERTAIN APPLICATIONS USING SEMICONDUCTOR PRODUCTS MAY INVOLVE POTENTIAL RISKS OF DEATH, PERSONAL INJURY, OR SEVERE PROPERTY OR ENVIRONMENTAL DAMAGE ("CRITICAL APPLICATIONS"). CIRRUS PRODUCTS ARE NOT DESIGNED, AUTHORIZED OR WARRANTED FOR USE IN AIRCRAFT SYSTEMS, MILITARY APPLICATIONS, PRODUCTS SURGICALLY IMPLANTED INTO THE BODY, AUTOMOTIVE SAFETY OR SECURITY DEVICES, LIFE SUPPORT PRODUCTS OR OTHER CRITICAL APPLICATIONS. INCLUSION OF CIRRUS PRODUCTS IN SUCH APPLICATIONS IS UNDERSTOOD TO BE FULLY AT THE CUSTOMER'S RISK AND CIRRUS DISCLAIMS AND MAKES NO WARRANTY, EXPRESS, STATUTORY OR IMPLIED, INCLUDING THE IMPLIED WARRANTIES OF MERCHANTABILITY AND FITNESS FOR PARTICULAR PURPOSE, WITH REGARD TO ANY CIRRUS PRODUCT THAT IS USED IN SUCH A MANNER. IF THE CUSTOMER OR CUSTOMER'S CUSTOMER USES OR PERMITS THE USE OF CIRRUS PRODUCTS IN CRITICAL APPLICATIONS, CUSTOMER AGREES, BY SUCH USE, TO FULLY INDEMNIFY CIRRUS, ITS OFFICERS, DIRECTORS, EMPLOYEES, DISTRIBUTORS AND OTHER AGENTS FROM ANY AND ALL LIABILITY, INCLUDING ATTORNEYS' FEES AND COSTS, THAT MAY RESULT FROM OR ARISE IN CONNECTION WITH THESE USES.

Cirrus Logic, Cirrus, and the Cirrus Logic logo designs are trademarks of Cirrus Logic, Inc. All other brand and product names in this document may be trademarks or service marks of their respective owners.

# AMEYA360

## Components Supply Platform

Authorized Distribution Brand :



Website :

Welcome to visit [www.ameya360.com](http://www.ameya360.com)

Contact Us :

➤ Address :

401 Building No.5, JiuGe Business Center, Lane 2301, Yishan Rd  
Minhang District, Shanghai , China

➤ Sales :

Direct +86 (21) 6401-6692

Email [amall@ameya360.com](mailto:amall@ameya360.com)

QQ 800077892

Skype [ameyasales1](#) [ameyasales2](#)

➤ Customer Service :

Email [service@ameya360.com](mailto:service@ameya360.com)

➤ Partnership :

Tel +86 (21) 64016692-8333

Email [mkt@ameya360.com](mailto:mkt@ameya360.com)