

CDS4150

MagnetoResistive Current Sensor ($I_{PN} = 150\text{ A}$)

Data sheet

The CDS4000 current sensor family is designed for highly dynamic electronic measurement of DC, AC, pulsed and mixed currents with integrated galvanic isolation. The MagnetoResistive technology enables an excellent dynamic response without the hysteresis that is present in iron core based designs.

The system accuracy can be improved by using either the internal or an external reference voltage. This further reduces temperature drift and several sensors can share the same reference voltage. The adjustable overcurrent detection enables a fast response in overload situations to prevent damage to the power units.

The CDS4000 product family offers PCB-mountable THT current sensors from 6 A up to 150 A nominal current for industrial applications.

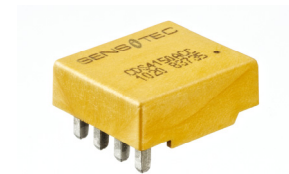

CDS4150ACC

Product overview

Product description	Package	Delivery Type
CDS4150ACC-KA	THT	Tray
CDK4150ACC-KA	Demoboard	Pocketbox

Quick reference guide

Symbol	Parameter	Min.	Typ.	Max.	Unit
V_{CC}	Supply voltage	4.75	5	5.25	V
I_{PN}	Primary nominal current (RMS)	-	-	150	A
I_{PR}	Primary measuring range ¹⁾	-450	-	+450	A
ϵ_{Σ}	Overall accuracy ²⁾	-	0.8	1.3	% of I_{PN}
f_{co}	Upper cut-off frequency (-1 dB)	200	400	-	kHz
T_{amb}	Ambient temperature ³⁾	-40	-	+105	°C
T_B	Busbar temperature ³⁾	-40	-	+105	°C

¹⁾ For 1 s in a 60 s interval; $R_M = 300\ \Omega$.

²⁾ Overall accuracy contains ϵ_G , ϵ_{off} and ϵ_{Lin} at $V_{CC} = 5\text{ V}$; $R_M = 300\ \Omega$; $T_{amb} = 25\text{ °C}$.

³⁾ Operating condition. Above +85 °C the PCB requires a RTI of minimum +130 °C.

Qualification overview

Standard	Name	Status
EN 61800-5-1: 2007-09	Adjustable speed electrical power drive systems	Approved
IEC 62103	Electronic equipment for use in power installations	Approved
DIN EN 50178	Electronic equipment for use in power installations	Approved
UL508	Power conversion equipment	Approved

Features

- Based on the Anisotropic MagnetoResistive (AMR) effect
- Galvanic isolation between primary and measurement circuit
- Single 5 V power supply
- Adjustable overcurrent detection

Advantages

- Excellent accuracy
- Low temperature drift
- Very small size
- Highly dynamic response
- External reference possible
- Low primary inductance
- Negligible hysteresis

Applications

- Solar power converters
- AC variable speed drives
- Converters for DC motor drives
- Uninterruptible power supplies
- Switched mode power supplies
- Power supplies for welding applications
- Laser diodes driver



CDS4150

MagnetoResistive Current Sensor ($I_{PN} = 150 \text{ A}$)

Electrical data

$T_{amb} = 25 \text{ }^\circ\text{C}$; $V_{CC} = 5 \text{ V}$; unless otherwise specified.

Symbol	Parameter	Conditions	Min.	Typ.	Max.	Unit
I_{PN}	Primary nominal current (RMS)		-	-	150	A
I_{PR}	Measuring range ¹⁾		-450	-	+450	A
I_{outN}	Nominal output current (RMS)	$I_P = I_{PN}$	-	2	-	mA
I_{outM}	Maximum output current (abs) ¹⁾	$I_P = 3 \cdot I_{PN}$	-	-	6	mA
R_M	Burden resistor for output signal ²⁾		100	300	1000	Ω
R_P	Resistance of primary conductor		50	70	90	$\mu\Omega$
R_i	Internal output resistor	See Fig. 1	9.5	10.5	11.5	k Ω
V_{CC}	Supply voltage		4.75	5	5.25	V
I_Q	Quiescent current	$I_P = 0$	-	25	30	mA
I_{CN}	Nominal current consumption	$I_P = I_{PN}$	-	50	60	mA
I_{CM}	Maximum current consumption	$I_P \leq I_{PR}$	-	100	110	mA
V_{out}	Maximum output voltage range ³⁾		0.625	-	4.375	V
V_{refout}	Reference voltage output	V_{refin} connected to GND	2.49	2.5	2.51	V
V_{refin}	Reference voltage input		1.5	2.5	2.6	V
G_V	Voltage gain	$R_M = 300 \Omega$	-	4	-	mV/A
G_I	Current gain		-	1/75	-	mA/A
I_L	Maximum additional load V_{refout}	$\Delta V_{refout} \leq 10 \text{ mV}$	-	-	1	mA

¹⁾ For 1 s in a 60 s interval; $R_M = 300 \Omega$.

²⁾ $R_M > 300 \Omega$: reduces I_{PR} but increases G_V .

³⁾ Output voltage is scaled by changing R_M but not beyond these limits. See Fig. 2.

Block diagram

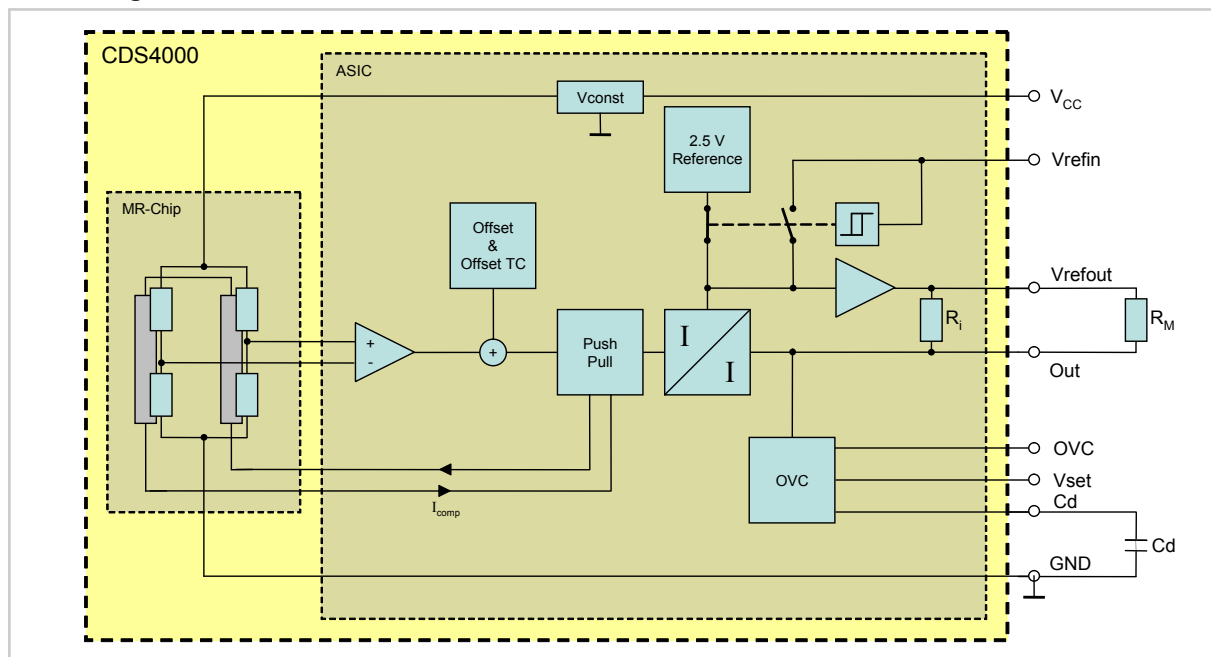

Fig. 1: Block diagram of CDS4000 current sensors.

CDS4150

MagnetoResistive Current Sensor ($I_{PN} = 150 \text{ A}$)

Accuracy

$T_{amb} = 25 \text{ °C}$; $V_{CC} = 5 \text{ V}$; $R_M = 300 \text{ } \Omega$; unless otherwise specified.

Symbol	Parameter	Conditions	Min.	Typ.	Max.	Unit
ϵ_{Σ}	Overall accuracy ¹⁾	$I_P \leq I_{PN}$	-	0.8	1.3	% of I_{PN}
ϵ_G	Gain error ²⁾	$I_P \leq I_{PN}$	-	0.3	0.5	% of I_{PN}
ϵ_{off}	Offset error ²⁾	$I_P = 0$	-	0.3	0.5	% of I_{PN}
ϵ_{Lin}	Linearity error ²⁾	$I_P \leq I_{PN}$	-	0.2	0.3	% of I_{PR}
$\epsilon_{Vrefint}$	Internal reference error		-10	0	+10	mV
$\epsilon_{Vrefext}$	External reference error ³⁾	$V_{refin} = 1.5 \text{ to } 2.6 \text{ V}$	-3	0	+3	mV
ϵ_{Hys}	Hysteresis ⁴⁾		-	-	0.1	% of I_{PN}
PSRR	Power supply rejection rate	$f_{\Delta V_{CC}} < 15 \text{ kHz}$	-	40	30	dB
N	Noise level (RMS)	$f < 300 \text{ kHz}$	-	1.7	-	μA

$T_{amb} = (-25 \dots +85) \text{ °C}$; $V_{CC} = 5 \text{ V}$; $R_M = 300 \text{ } \Omega$; unless otherwise specified.

Symbol	Parameter	Conditions	Min.	Typ.	Max.	Unit
$T\epsilon_G$	Maximum temperature induced gain error		-0.5	0	+0.5	% of I_{PN}
$T\epsilon_{off}$	Maximum temperature induced offset error		-1.5	0	+1.5	% of I_{PN}
$T\epsilon_{Lin}$	Maximum temperature induced linearity error		-	0	0.1	% of $2 \cdot I_{PN}$
$T\epsilon_{Vrefint}$	Maximum temperature induced error of internal reference	$I_P \leq I_{PN}$	-0.6	0	+0.6	% of V_{refout}
$T\epsilon_{Vrefext}$	Maximum temperature induced error of external reference		-0.05	0	+0.05	% of V_{refout}

$T_{amb} = (-40 \dots +105) \text{ °C}$; $V_{CC} = 5 \text{ V}$; $R_M = 300 \text{ } \Omega$; unless otherwise specified.

Symbol	Parameter	Conditions	Min.	Typ.	Max.	Unit
$T\epsilon_G$	Maximum temperature induced gain error		-0.5	0	+0.5	% of I_{PN}
$T\epsilon_{off}$	Maximum temperature induced offset error		-2.0	0	+2.0	% of I_{PN}
$T\epsilon_{Lin}$	Maximum temperature induced linearity error		-	0	0.1	% of $2 \cdot I_{PN}$
$T\epsilon_{Vrefint}$	Maximum temperature induced error of internal reference	$I_P \leq I_{PN}$	-0.6	0	+0.6	% of V_{refout}
$T\epsilon_{Vrefext}$	Maximum temperature induced error of external reference		-0.05	0	+0.05	% of V_{refout}

Notes

- ¹⁾ Overall accuracy contains ϵ_G , ϵ_{off} and ϵ_{Lin} .
- ²⁾ Long term stability after 10,000 hours at 85 °C operating temperature:
The gain and linearity error is less than $\pm 1.8 \%$ of I_{PN} .
The offset error is less than $\pm 2.0 \%$ of I_{PN} .
- ³⁾ $\epsilon_{Vrefext} = V_{refin} - V_{refout}$
- ⁴⁾ Residual voltage after $3 \cdot I_{PN}$ DC.

CDS4150

MagnetoResistive Current Sensor ($I_{PN} = 150\text{ A}$)

Absolute maximum ratings

In accordance with the absolute maximum rating system (IEC60134).

Symbol	Parameter	Min.	Max.	Unit
V_{CC}	Supply voltage	-0.3	+7	V
I_{PM}	Maximum primary current ¹⁾	-	1500	A
T_{amb}	Ambient temperature	-40	+105	°C
T_{stg}	Storage temperature	-40	+105	°C
T_B	Busbar temperature	-40	+105	°C

¹⁾ For 3 ms in a 100 ms interval.

Stresses beyond those listed under "Absolute Maximum Ratings" may cause permanent damage to the device. This is a stress rating only and functional operation of the device at these or any other conditions beyond those indicated in the operational sections of this specification is not implied. Exposure to absolute maximum rating conditions for extended periods may affect device reliability.

Qualifications

Symbol	Parameter	Conditions	Min.	Typ.	Max.	Unit
V_I	Isolation test voltage (RMS)	50/60 Hz, 60 s	-	5	-	kV
V_{imp}	Impulse withstand voltage	1.2/50 μ s	-	12	-	kV
V_{pde}	Partial discharge extinction voltage		1900	-	-	V
d_{cp}	Creepage distance		-	15	-	mm
d_{cl}	Clearance distance		-	15	-	mm
CTI	Comparative Tracking Index		-	600	-	-

Dynamical data

$T_{amb} = 25\text{ °C}$; $V_{CC} = 5\text{ V}$; unless otherwise specified.

Symbol	Parameter	Conditions	Min.	Typ.	Max.	Unit
t_{reac}	Reaction time ²⁾	10% I_{PN} to 10% $I_{out,N}$	-	-	0.45	μ s
t_{rise}	Rise time ²⁾	10% $I_{out,N}$ to 90% $I_{out,N}$	-	-	0.55	μ s
t_{resp}	Response time ²⁾	90% I_{PN} to 90% $I_{out,N}$	-	-	0.35	μ s
f_{co}	Upper cut-off frequency	-1 dB	200	400	-	kHz

²⁾ $I_P = I_{PN}$ with di/dt of 200 A/ μ s. See Fig. 3.

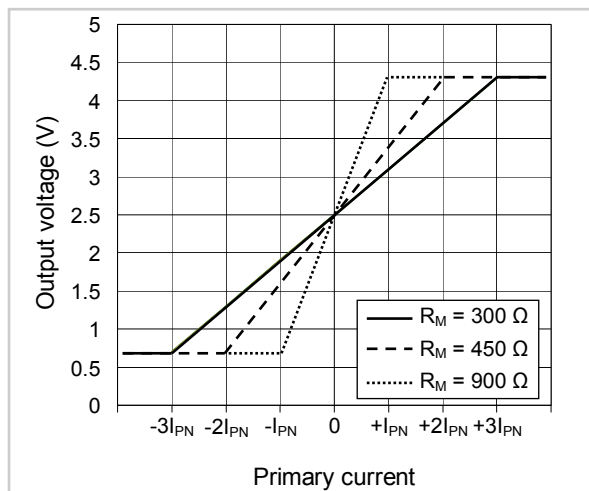

Fig. 2: Characteristic of primary current to output voltage according to different R_M . $V_{refout} = 2.5\text{ V}$.

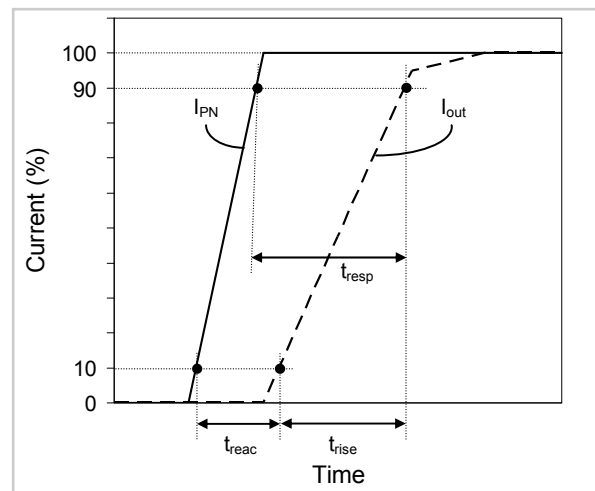

Fig. 3: Definition of reaction time (t_{reac}), rise time (t_{rise}) and response time (t_{resp}).

CDS4150

MagnetoResistive Current Sensor ($I_{PN} = 150 \text{ A}$)

General data

Symbol	Parameter	Conditions	Min.	Typ.	Max.	Unit
T_{amb}	Ambient temperature ¹⁾		-40	-	+105	°C
T_{stg}	Storage temperature ¹⁾		-40	-	+105	°C
T_B	Busbar temperature ¹⁾		-40	-	+105	°C
T_{THT}	Solder temperature	For 7 seconds	-	-	260	°C
m	Mass CDS4150ACC		-	10.8	-	g
RTI	Relative temperature index ¹⁾	$T_{amb} \geq +85 \text{ °C}$	+130	-	-	°C

¹⁾ Operating condition. Above +85 °C the PCB requires a RTI of minimum +130 °C.

Overcurrent detection (OVC) related data

The CDS4150 current sensor offers with OVC a digital comparator output to signal primary current overloads. The output is pulled low when a user defined critical current value is exceeded. The overcurrent detection is adjustable for both threshold voltage and delay time. The OVC output is an open collector output with internal 10 kΩ pull up resistor.

A maximum of 3 CDS (for 3-Phase-detection) can be connected in parallel as a wired-or signal.

$T_{amb} = 25 \text{ °C}$; $V_{CC} = 5 \text{ V}$; unless otherwise specified.

Symbol	Parameter	Conditions	Min.	Typ.	Max.	Unit
V_{OVCH}	Overcurrent output high level		4.5	-	5	V
V_{OVCL}	Overcurrent output low level		0	-	0.7	V
V_{set}	Threshold input		0.625	-	2.5	V
$\epsilon_{OVCVset}$	Error of OVC Threshold	$R_M = 300 \text{ } \Omega$, $I_P = I_{PN}$	-3	-	+3	% of $V_{out,N}$
ϵ_{OVCHys}	Switching Hysteresis		1	5	10	mV
R_D	Internal pull up resistance		7	10	13	kΩ
I_S	Maximum current sink at OVC output		-	-	2	mA

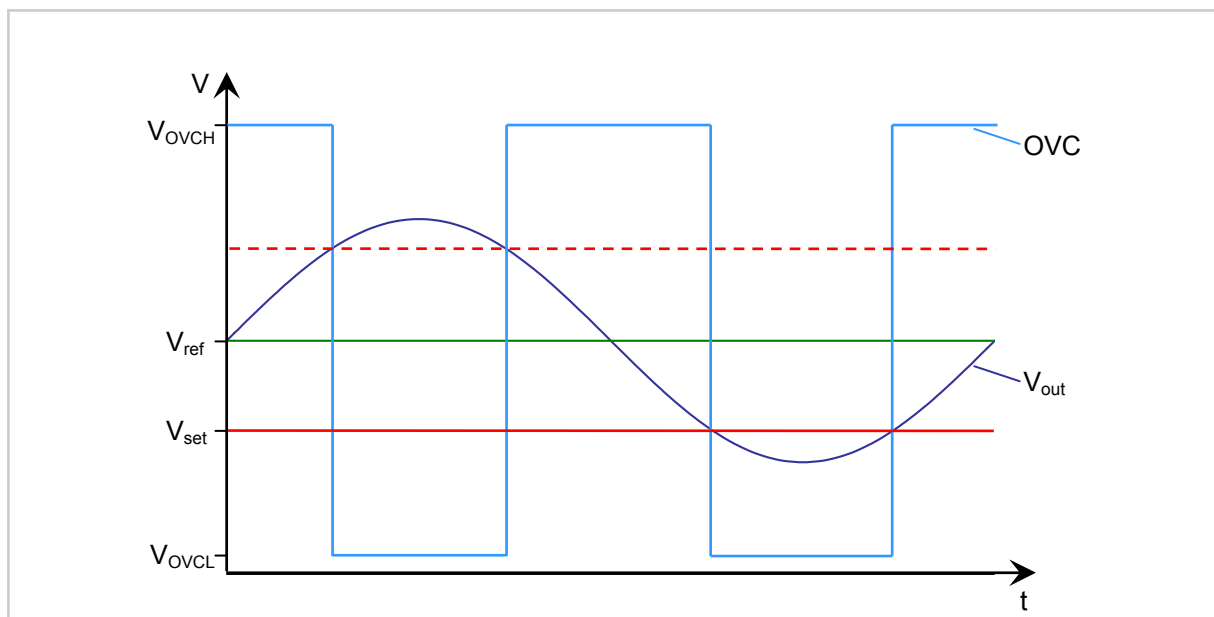

Fig. 4: Response of the overcurrent detection. Positive and negative overcurrents will be detected.

CDS4150

MagnetoResistive Current Sensor ($I_{PN} = 150\text{ A}$)

CDS4150 in THT-housing

Pinning

Pin	Symbol	Parameter
1	V_{refout}	Reference voltage output
2	Out	Signal output
3	GND	Ground
4	V_{cc}	Supply voltage
5	V_{refin}	External reference voltage input
6	C_d	Overcurrent delay capacitor input
7	OVC	Overcurrent detection output
8	V_{set}	Threshold voltage for overcurrent detection
9	I_{in}	Primary current input
10	I_{out}	Primary current output

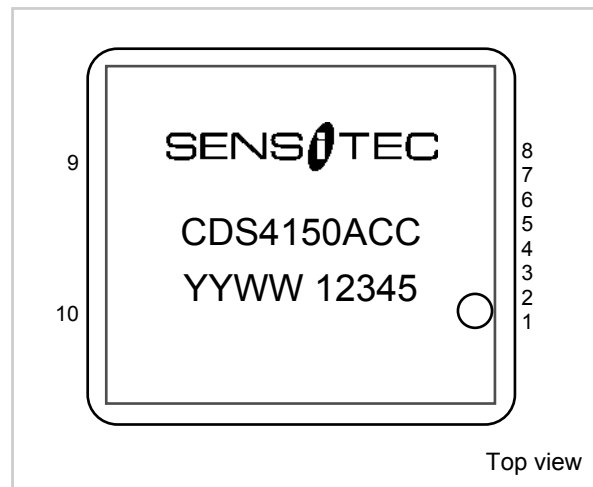

Fig. 5: Pinning of CDS4150ACC.

Dimensions

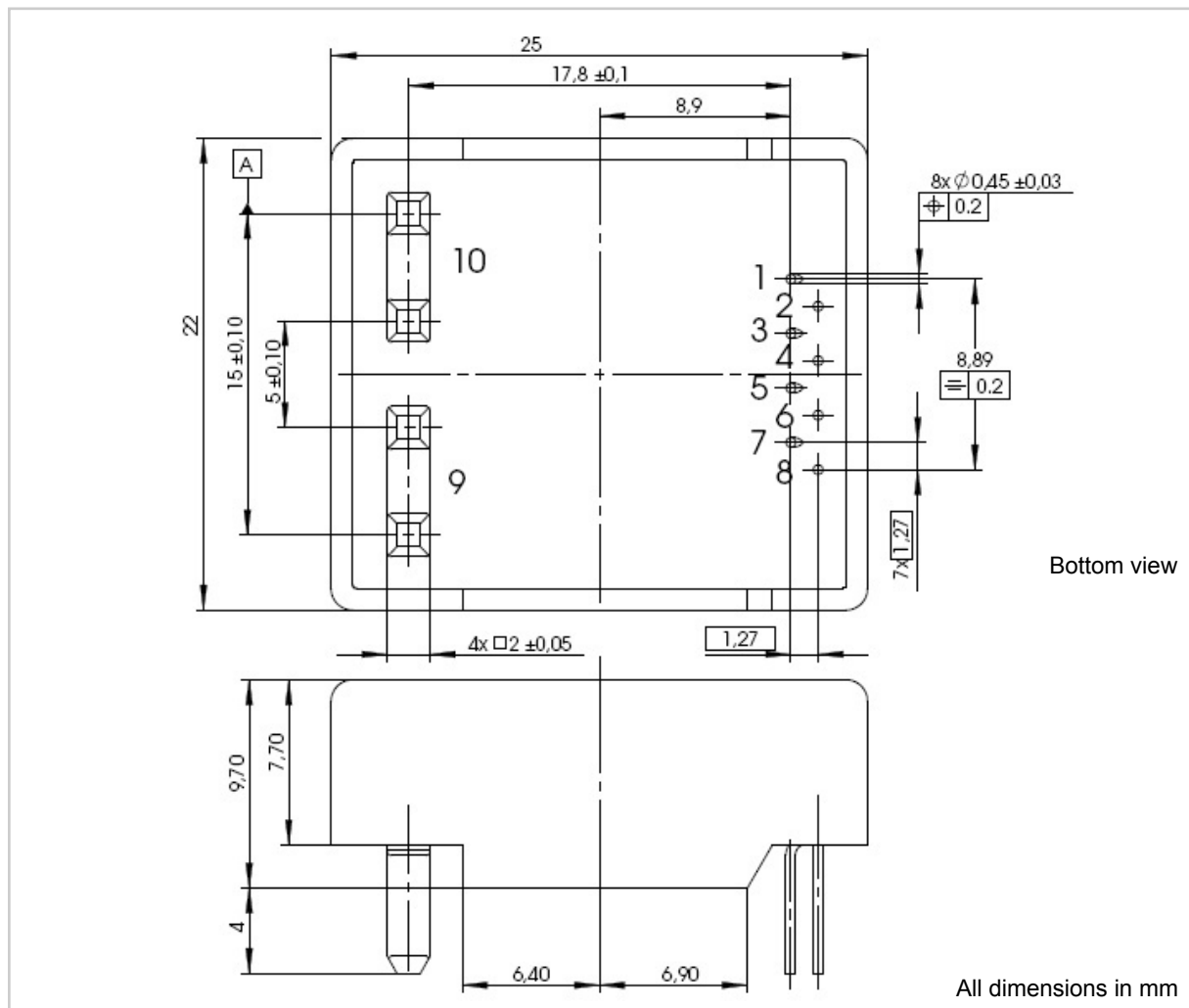

Fig. 6: Package outline of THT-housing. Tolerance $\pm 0.2\text{ mm}$ unless otherwise specified.

CDS4150

MagnetoResistive Current Sensor ($I_{PN} = 150 \text{ A}$)

Application circuit

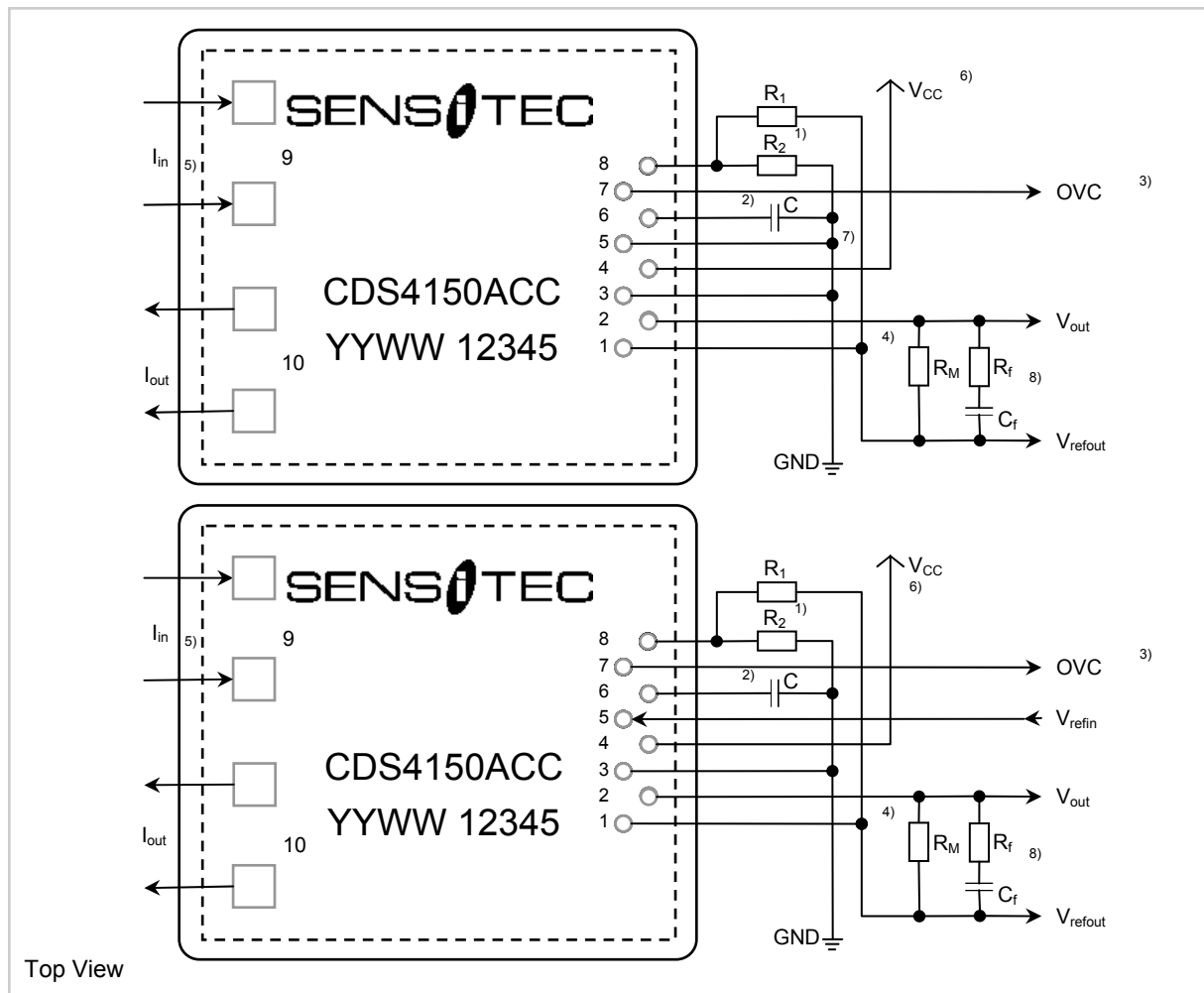

Fig. 7: *Top*: Example of how to use the internal reference voltage (pin 5, V_{refin} is routed on ground).
Bottom: Circuit with external reference voltage at pin 5, V_{refin} .

Notes

¹⁾ The overcurrent threshold is set by applying a voltage to pin 8 (V_{set}) according to the formula:

$$V_{set} = V_{refout} - I_{OC} \cdot R_M \cdot G_1 \quad \text{Example: } V_{refout} = 2.5 \text{ V; } R_M = 300 \Omega; I_{OC} = 300 \text{ A} \rightarrow V_{set} = \underline{1.3 \text{ V}}$$

In the above Fig. 7 the potential divider with R_1 and R_2 on pin 8 (V_{set}) is used to adjust the threshold for the overcurrent detection. In consideration of internal $60 \text{ k}\Omega$ in parallel to R_1 the divider calculates as follows:

$$\frac{V_{set}}{V_{refout}} = \frac{R_2}{\frac{R_1 \cdot 60 \text{ k}\Omega}{R_1 + 60 \text{ k}\Omega} + R_2} \quad \text{with } 1.0 \text{ k}\Omega < (R_1 + R_2) < 7.5 \text{ k}\Omega \text{ and } R_1 \text{ or } R_2 < 1.0 \text{ k}\Omega.$$

²⁾ The overcurrent delay time is adjustable with the capacitor C_d on pin 6. Without C_d the delay time has its minimum value. The minimum delay time is achieved by not using a capacity C_d (not connected on ground).

$$t_d \approx 0.5 \mu\text{s} + \frac{C_d (\text{pF})}{50 \text{ pF}} \mu\text{s} \quad \text{or } C_d \approx 50 \text{ pF} \cdot (t_d (\mu\text{s}) - 0.5 \mu\text{s}).$$

³⁾ If the overcurrent detection is unused, V_{set} and C_d should be routed on ground, OVC pin is not connected.

⁴⁾ $R_M > 300 \Omega$: reduces I_{PR} but increases G_V . See Fig. 2.

$$\text{Output voltage depending on primary current as: } V_{out} = V_{refout} + I_P \cdot G_1 \cdot 1.03 \cdot \frac{R_i \cdot R_M}{R_i + R_M}$$

⁵⁾ V_{out} is positive, if I_P flows from pin 9 "I_{in}" to pin 10 "I_{out}".

⁶⁾ V_{CC} should always be buffered with a capacity of at least 100 nF .

⁷⁾ V_{refin} should always be routed on ground if not used.

⁸⁾ An additional RC-filter is recommended for frequency response correction. $R_f = 1.0 \text{ k}\Omega$; $C_f = 39 \text{ nF}$.

CDS4150

MagnetoResistive Current Sensor ($I_{PN} = 150 \text{ A}$)

Application circuit

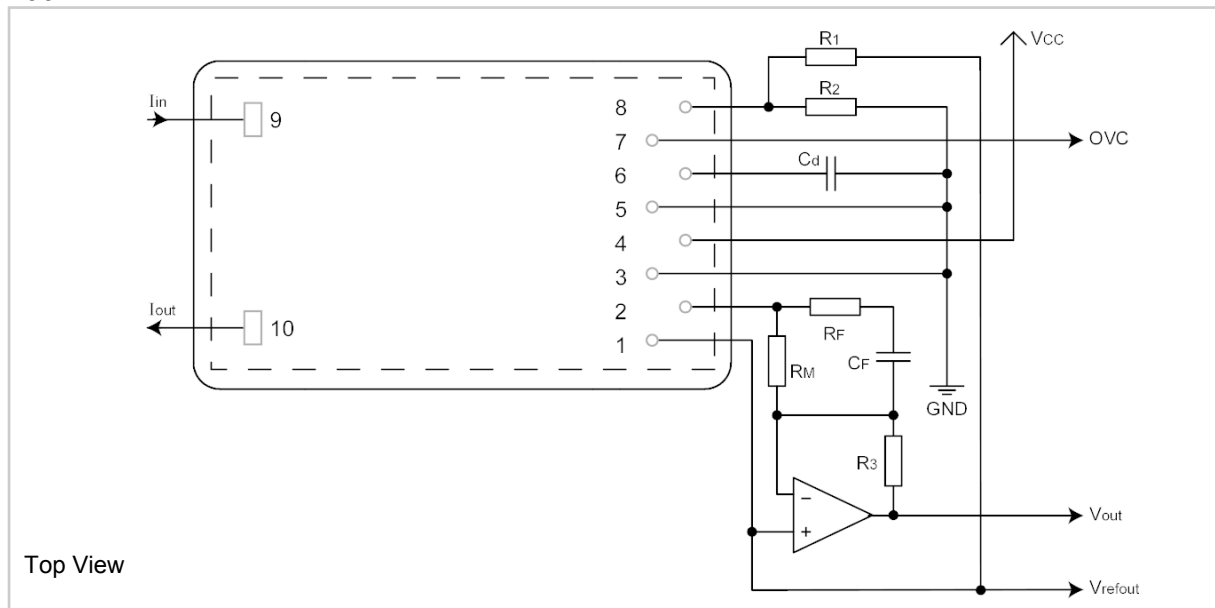

Fig. 8: Example of how to use an operational amplifier to adjust the output signal to an A/D converter. With $R_M = 300 \Omega$ and $R_3 = 410 \Omega$, the output signal is amplified to a full scale output of 4.92 V.

PCB layout

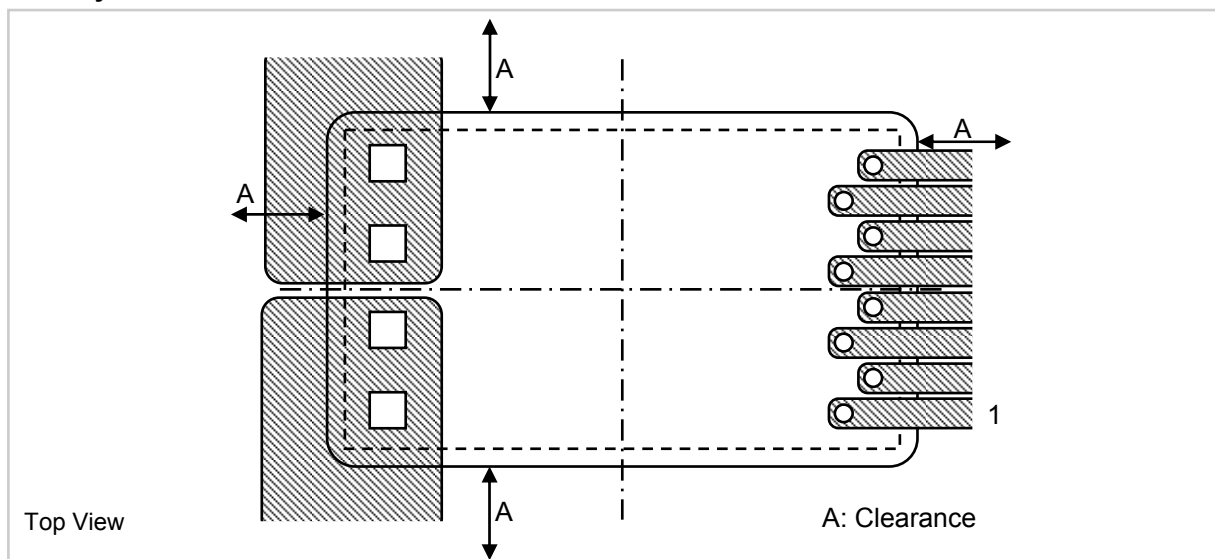

Fig. 9: Recommended PCB layout for the CDS4150 sensor (schematic).

Additional notes for the designer

- The minimum clearance to other magnetic devices (for example: relay, current conductors and permanent magnets) depends on the strength of their magnetic field. Homogeneous fields should be below 1 kA/m and magnetic field gradients should be lower than 4 kA/m². A conductor carrying 1 A produces a magnetic field of 20 A/m and a magnetic field gradient of 2.5 kA/m² at a distance of 8 mm.
- The maximum operating temperature is primarily limited by the busbar temperature. Care must be taken to keep the busbar temperature below 105 °C.
- It is recommended to place multiple CDS4150 sensors with a clearance (A) of at least 20 mm. A smaller distance will cause cross-talk to adjacent sensors. The current paths in the PCB however may not be routed underneath a CDS4000 sensor.
- Above the ambient temperature of +85 °C a relative temperature index (RTI) of minimum +130 °C is required for the PCB.

Typical performance graphs

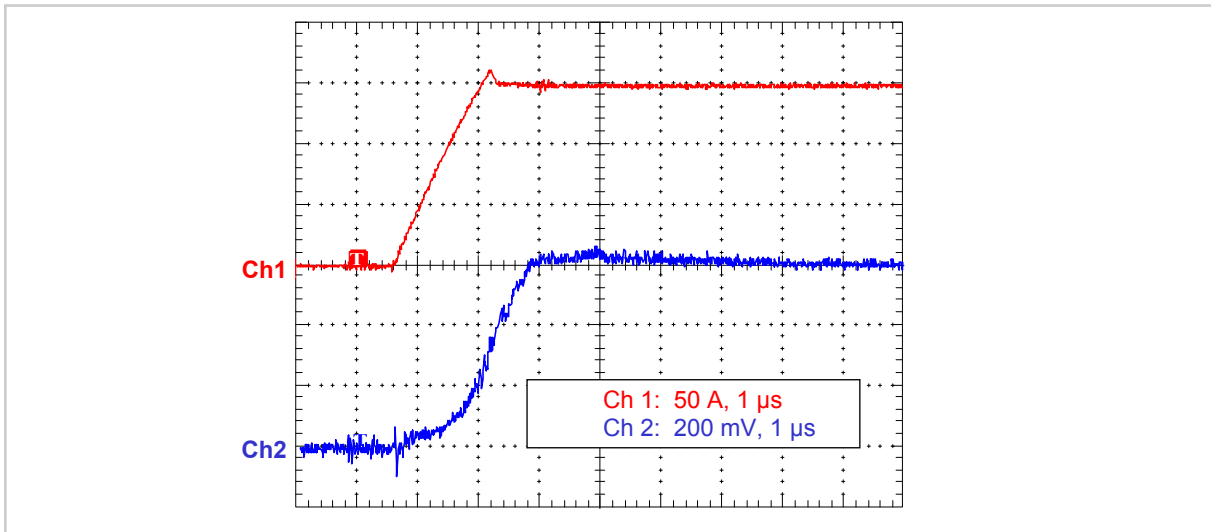

Fig. 10: Typical output characteristic due to a current jump from 0 to I_{PN} . Input $di/dt \approx 120 \text{ A}/\mu\text{s}$. An RC-filter with the parameters $R_f = 1.0 \text{ k}\Omega$ and $C_f = 39 \text{ nF}$ is used.

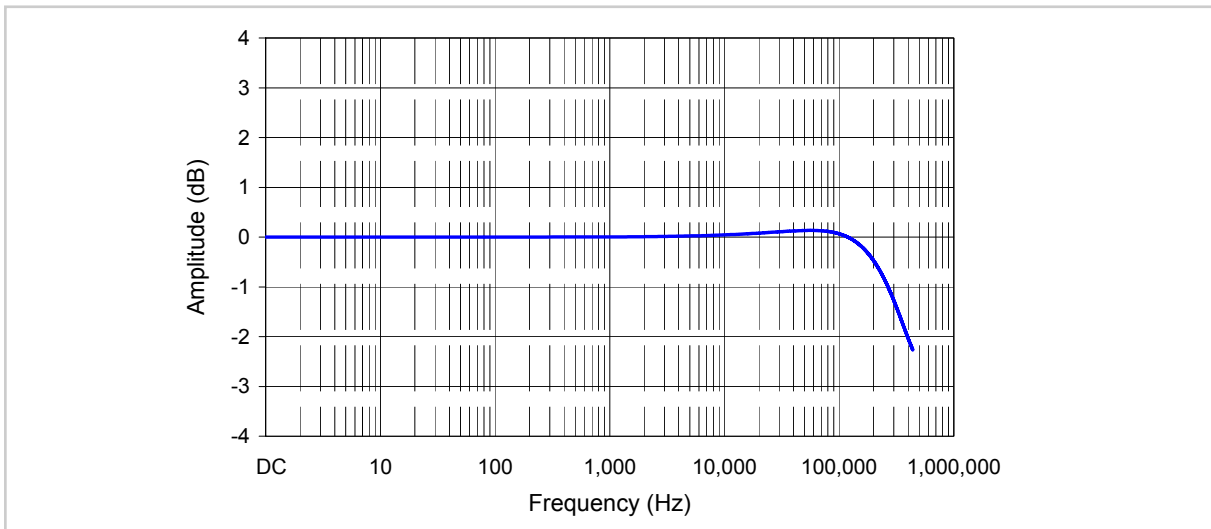

Fig. 11: Typical frequency response by using a RC-filter with the parameters $R_f = 1.0 \text{ k}\Omega$ and $C_f = 39 \text{ nF}$.

Safety notes

	<p>Warning! This sensor shall be used in electric and electronic devices according to applicable standards and safety requirements. Sensitec's datasheet and handling instructions must be complied with. Handling instructions for current sensors are available at www.sensitec.com.</p>
	<p>Caution! Risk of electric shock! When operating the sensor, certain parts, e. g. the primary busbar or the power supply, may carry hazardous voltage. Ignoring this warning may lead to serious injuries! Conducting parts of the sensor shall not be accessible after installation.</p>

CDS4150

MagnetoResistive Current Sensor ($I_{PN} = 150\text{ A}$)

The CDS4000 product family

The CDS4150 is a member of the CDS4000 product family offering PCB-mountable THT current sensors from 6 A up to 150 A nominal current for various industrial applications.

For each sensor type a demoboard for evaluation and testing is available.

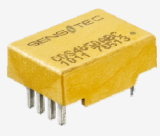
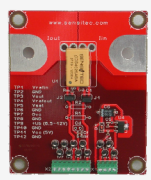
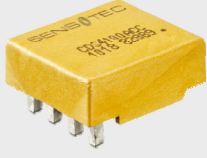
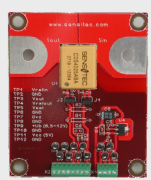
Product	I_{PN} (A)	I_{PR} (A)	Package	Demoboard
CDS4006ABC-KA	6	18		
CDS4010ABC-KA	10	30		
CDS4015ABC-KA	15	45		
CDS4025ABC-KA	25	75		
CDS4050ABC-KA	50	150		
CDS4050ACC-KA	50	150		
CDS4100ACC-KA	100	300		
CDS4125ACC-KA	125	375		
CDS4150ACC-KA	150	450		

I_{PN} : Nominal primary current (RMS).

I_{PR} : Measurement range (For 1 s in a 60 s interval; $R_M = 300\ \Omega$).

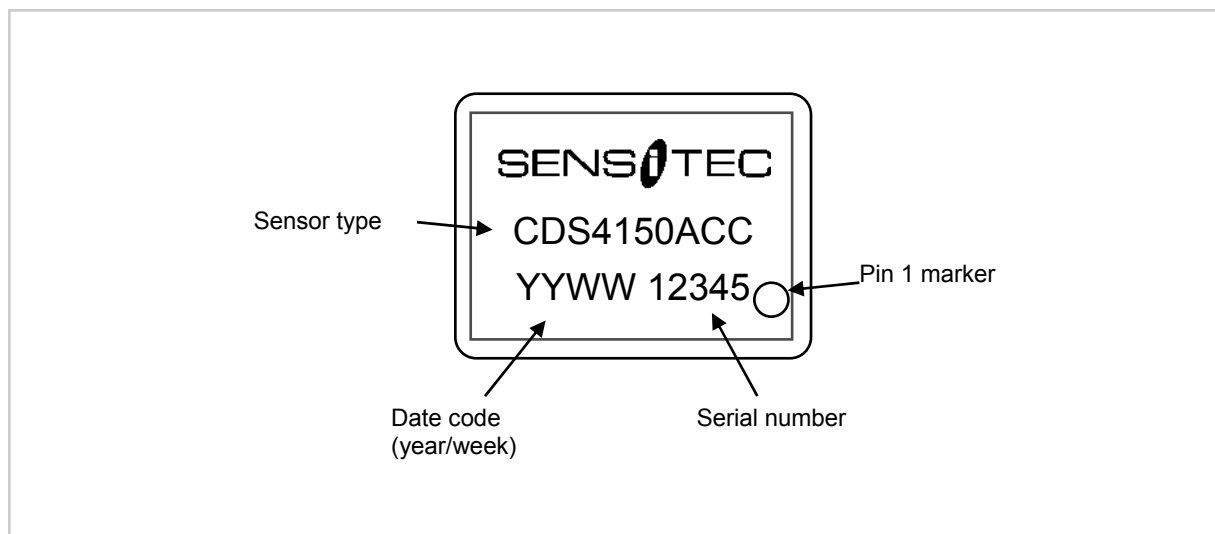

Fig. 12: Sensor inscription.

CDS4150

MagnetoResistive Current Sensor ($I_{PN} = 150 \text{ A}$)

General information**Product status**

The product is in series production.

Note: The status of the product may have changed since this data sheet was published.
The latest information is available on the internet at www.sensitec.com.

Disclaimer

Sensitec GmbH reserves the right to make changes, without notice, in the products, including software, described or contained herein in order to improve design and/or performance. Information in this document is believed to be accurate and reliable. However, Sensitec GmbH does not give any representations or warranties, expressed or implied, as to the accuracy or completeness of such information and shall have no liability for the consequences of use of such information. Sensitec GmbH takes no responsibility for the content in this document if provided by an information source outside of Sensitec products.

In no event shall Sensitec GmbH be liable for any indirect, incidental, punitive, special or consequential damages (including but not limited to lost profits, lost savings, business interruption, costs related to the removal or replacement of any products or rework charges) irrespective the legal base the claims are based on, including but not limited to tort (including negligence), warranty, breach of contract, equity or any other legal theory.

Notwithstanding any damages that customer might incur for any reason whatsoever, Sensitec product aggregate and cumulative liability towards customer for the products described herein shall be limited in accordance with the General Terms and Conditions of Sale of Sensitec GmbH.

Nothing in this document may be interpreted or construed as an offer to sell products that is open for acceptance or the grant, conveyance or implication of any license under any copyrights, patents or other industrial or intellectual property rights.

Unless otherwise agreed upon in an individual agreement Sensitec products sold are subject to the General Terms and Conditions of Sales as published at www.sensitec.com.

Application information

Applications that are described herein for any of these products are for illustrative purposes only. Sensitec GmbH makes no representation or warranty – whether expressed or implied – that such applications will be suitable for the specified use without further testing or modification.

Customers are responsible for the design and operation of their applications and products using Sensitec products, and Sensitec GmbH accepts no liability for any assistance with applications or customer product design. It is customer's sole responsibility to determine whether the Sensitec product is suitable and fit for the customer's applications and products planned, as well as for the planned application and use of customer's third party customer(s). Customers should provide appropriate design and operating safeguards to minimize the risks associated with their applications and products.

Sensitec GmbH does not accept any liability related to any default, damage, costs or problem which is based on any weakness or default in the customer's applications or products, or the application or use by customer's third party customer(s). Customer is responsible for doing all necessary testing for the customer's applications and products using Sensitec products in order to avoid a default of the applications and the products or of the application or use by customer's third party customer(s). Sensitec does not accept any liability in this respect.

Life critical applications

These products are not qualified for use in life support appliances, aeronautical applications or devices or systems where malfunction of these products can reasonably be expected to result in personal injury.

SENSITEC

MagnetoResistive Sensors

Sensitec GmbH
Georg-Ohm-Straße 11
35633 Lahnau
Germany
Fon +49 (0) 6441 9788-0
Fax +49 (0) 6441 9788-17
E-Mail info@sensitec.com
www.sensitec.com

Solutions for measuring:

- Position
- Angle
- Magnetic field
- Current

Copyright © 2012 by Sensitec GmbH, Germany

All rights reserved. No part of this document may be copied or reproduced in any form or by any means without the prior written agreement of the copyright owner. The information in this document is subject to change without notice. Please observe that typical values cannot be guaranteed.

Sensitec GmbH does not assume any liability for any consequence of its use.