



1.0 Features

- Fixed-function mass storage device—requires no firmware code
- USB *Mass Storage Class Bulk-Only* specification-compliant (version 1.0)
- USB 2.0-certified (TID# 40001426)
 - Integrated USB transceiver
 - High-speed (480-Mbit) and full-speed (12-Mbit) support
 - USB Suspend/Resume, Remote Wakeup support
- Two power modes of operation—self-powered and USB bus-powered
 - Low power consumption allows for bus-powered operation
 - VBUS-powered CF support
 - True USB portable HDD support
- Compact 80-pin TQFP package with a Lead-Free option
- *ATA/ATAPI-6* specification-compliant—provides support for mass storage devices larger than 137GB
- 5V tolerant inputs, 3.3V output drive
- Flexible USB descriptor and configuration retrieval sources
 - I²C-compatible serial ROM interface
 - ATA interface using vendor-specific ATA command (FBh) implemented on ATAPI or ATA device
 - Default on-chip ROM contents for manufacturing/development
- 2-Kbyte SRAM data buffer for ATA/ATAPI data transfers
- ATA interface supports ATA PIO modes 0–4, UDMA modes 0–4 (multiword DMA not supported). ATA interface operation mode is automatically selected during device initialization or manually programmed with I²C-compatible configuration data
- Automatic detection of either Master or Slave ATA/ATAPI devices
- Mode Page 5 Support—increased support for formatting removable media devices
- ATA Interrupt support for ATAPI devices—offers more robust ATA support across OS platforms
- System event notification via Vendor-specific ATA command
 - Input pin for media cartridge detection or ejection request
 - USB bus state indications (Reset, FS/HS mode of operation, Suspend/Resume, Bus/Self-powered)

- Three General Purpose I/O (GPIO) pins
- Multiple LUNs supported within a single ATAPI device
- ATA translation provides seamless ATA support with standard MSC drivers
- Additional ATA command support provided by vendor-specific ATACBs (ATA command blocks utilizing the MSC Command Block Wrapper)
- Provisions to share ATA bus with other hosts (e.g. USB/1394 dual device)
- Manufacturing interconnect test support provided with vendor-specific USB commands:
 - Read/Write access to relevant ASIC pins
 - Manufacturing Interconnect Test Tools
- Utilizes inexpensive 30-Mhz crystal for clock source.

1.1 Functional Block Diagram

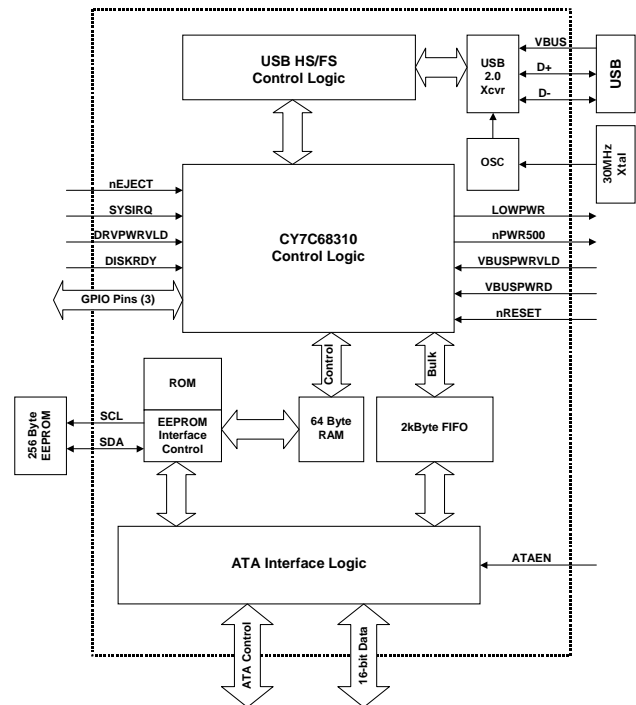

Figure 1-1. Block Diagram



2.0 Applications

The CY7C68310 implements a USB 2.0 bridge for all ATA/ATAPI-6 compliant mass storage devices, such as:

- Hard drives, including small form factor drives (2.5", 1.8", and 1.0") designed for portable consumer electronics applications
- CD-ROM, CD-R/W
- DVD-ROM, DVD-RAM, DVD-R/W
- MP3 players
- Compact flash
- Microdrives
- Tape drives
- Personal video recorders.

2.1 Additional Resources

- CY4617 – CY7C68310 Mass Storage Reference Design Kit
- *USB Specification* version 2.0
- ATA Attachment-6 with Packet Interface revision 3b
- *USB Mass Storage Class Bulk-Only Transport* specification, Rev. 1.0

3.0 Introduction

The CY7C68310 implements a bridge between one USB port and one ATA/ATAPI-based mass storage device port. This bridge adheres to the *Mass Storage Class Bulk-Only Transport* specification, version 1.0.

The USB port of the CY7C68310 is connected to a host computer directly or via the downstream port of a USB hub. Host software issues commands and data to the CY7C68310 and receives status and data from the CY7C68310 using standard USB protocol.

The ATA/ATAPI port of the CY7C68310 is connected to a mass storage device. A 2-Kbyte buffer maximizes ATA/ATAPI data transfer rates by minimizing losses due to device seek times. The ATA interface supports ATA PIO modes 0–4, and Ultra Mode DMA modes 0–4.

The device initialization process is configurable, enabling the CY7C68310 to initialize most ATA/ATAPI devices without software intervention. The CY7C68310 can also be configured to allow software initialization of a device if initialization requirements are not supported by CY7C68310 algorithms.

4.0 Pin Assignments

4.1 Pin Diagram

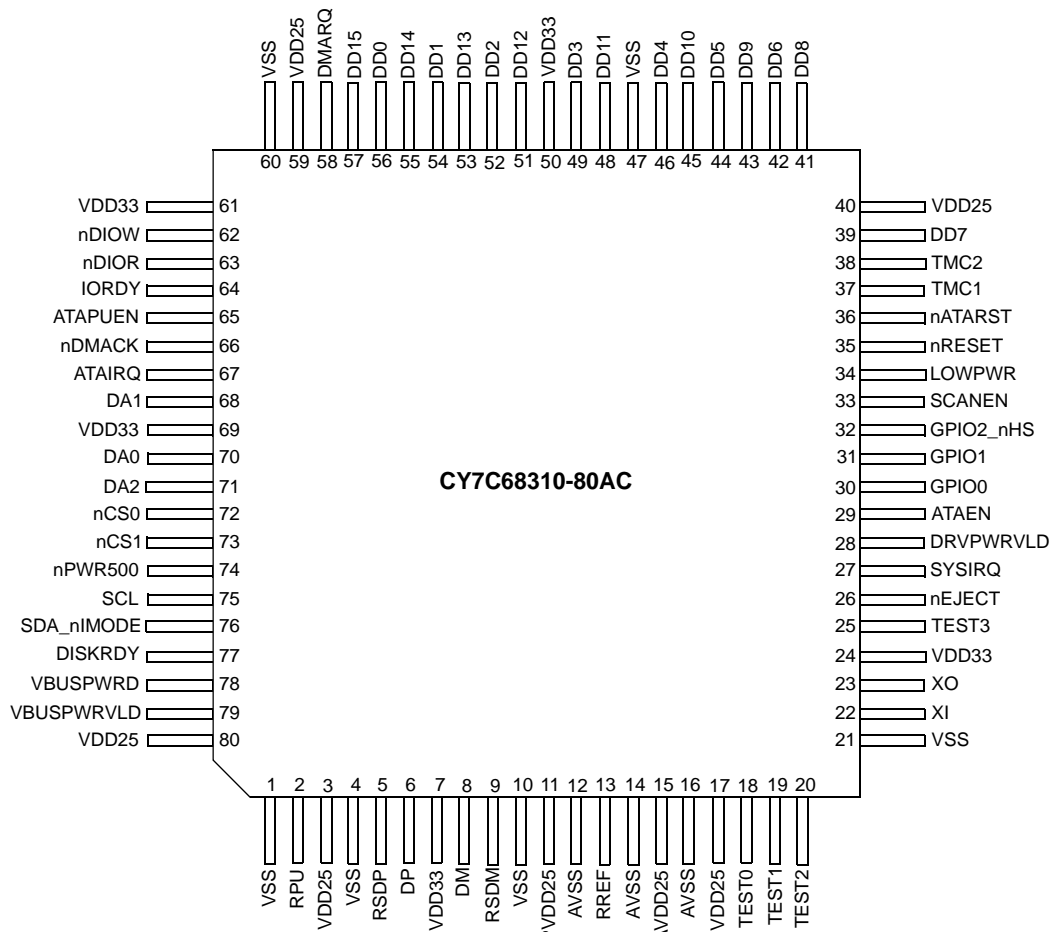

Figure 4-1. 80-pin TQFP

4.2 Pin Overview

Pin Number	Pin Name	Pin Direction	Pin Type	Pin Description
2	RPU	O	USB Output	D+ pull-up source. Power source for 1.5k pull-up resistor attached to D+ during full-speed operation.
5	RSDP	O	USB I/O	USB full-speed output buffer (D+). RSDP also functions as a current sink for termination during high-speed operation.
6	DP	I/O	USB I/O	USB high-speed I/O buffer (D+).
8	DM	I/O	USB I/O	USB high-speed I/O buffer (D-).
9	RSDM	O	USB I/O	USB full-speed output buffer (D-). RSDM also functions as a current sink for termination during high-speed operation.
18–20, 25	TEST[0:3]	I	5V-tolerant input buffer	Active HIGH. ASIC fabrication and manufacturing test mode select. These pins must be tied to GND during normal operation.
22	XI	I	OSC input (2.5V-tolerant)	30-MHz crystal input.
23	XO	O	OSC output	30-MHz crystal output.
26	nEJECT	I	5V-tolerant Schmitt input	Active LOW. Media eject or remote wakeup requested. Tie to +3.3V if functionality is not used.
27	SYSIRQ	I	5V-tolerant Schmitt input	Active HIGH. USB interrupt request. Tie to GND if functionality is not used.
28	DRVPRVLD	I	5V-tolerant Schmitt input	Configurable polarity. Device Presence Detect. This pin must not be allowed to float if functionality is not utilized.
29	ATAEN	I	5V-tolerant Schmitt input	Active HIGH. ATA interface enable. '1' = normal ATA operation '0' = High-Z ATA interface pins and ATA interface logic halted
30–32	GPIO[0:1], GPIO2_nHS	I/O	3.3V drive, 5V-tolerant, 6-mA I _{OL} , Schmitt input	General purpose I/O pins. The GPIO pins must be tied to GND if functionality is not utilized. If the hs_indicator config bit is set, the GPIO2_nHS pin will reflect the operating speed of the device. '1' = full-speed operation '0' = high-speed operation
33	SCANEN	I	5V tolerant input buffer	Active HIGH. ASIC test pin. This pin must be tied to GND during normal operation.
34	LOWPWR	O	high-Z driver, 5V-tolerant, 6-mA I _{OL}	Active HIGH. USB suspend indicator. '0' = Chip active. VBUS power up to 100 mA granted. 'High-Z' = Chip suspend. VBUS system current limited to USB suspend mode value.
35	nRESET	I	5V-tolerant Schmitt input	Active LOW. Asynchronous chip reset.
36	nATARST	O	3.3V drive, 5V-tolerant, 6-mA I _{OL}	Active LOW. ATA reset signal.
37, 38	TMC[1:2]	I	3.3V input	Active HIGH. ASIC test pins. These pins must be tied to GND during normal operation.
56, 54, 52, 49, 46, 44, 42, 39, 41, 43, 45, 48, 51, 53, 55, 57	DD[0:15]	I/O	3.3V drive, 5V-tolerant, 6-mA I _{OL} , Schmitt input	ATA data signals.
58	DMARQ	I	5V tolerant Schmitt input	ATA control signal.
62	nDIOW	O	3.3V drive, 5V-tolerant, 6-mA I _{OL}	ATA control signal.

4.2 Pin Overview (continued)

Pin Number	Pin Name	Pin Direction	Pin Type	Pin Description
63	nDIOR	O	3.3V drive, 5V-tolerant, 6 mA I _{OL}	ATA control signal.
64	IORDY	I	5V-tolerant Schmitt input	ATA control signal.
65	ATAPUEN	O	3.3V drive, 5V-tolerant, 6 mA I _{OL}	ATA IORDY pull-up connection. For VBUS-powered systems.
66	nDMACK	O	3.3V drive, 5V-tolerant, 6 mA I _{OL}	ATA control signal.
67	ATAIRQ	I	5V-tolerant Schmitt input	ATA interrupt request.
70, 68, 71	DA[0:2]	O	3.3V drive, 5V-tolerant, 6 mA I _{OL}	ATA address signals.
72, 73	nCS[0:1]	O	3.3V drive, 5V-tolerant, 6 mA I _{OL}	ATA chip select signals.
74	nPWR500	O	high-Z driver, 5V-tolerant, 6 mA I _{OL}	Active LOW. VBUS power granted indicator. '0' = VBUS power up to bMaxPower value 'high-Z' = bMaxPower value not granted (if more than 100 mA)
75	SCL	O	high-Z driver, 5V-tolerant, 6 mA I _{OL}	I²C-compatible clock. This pin may be left as a no-connect pin if the I ² C-compatible interface is not utilized.
76	SDA_nIMODE	I/O	high-Z driver, 5V-tolerant, 6 mA I _{OL} , Schmitt input	I²C-compatible address/data or nIMODE select.
77	DISKRDY	I	5V-tolerant Schmitt input	Configurable polarity. Device ready.
78	VBUSPWRD	I	5V-tolerant Schmitt input	Active HIGH. Bus-powered operation select pin. '1' = Bus powered '0' = Self powered
79	VBUSPWRVLD	I	5V-tolerant Schmitt input	Active HIGH. Indicates that VBUS power is present.
1, 4, 10, 21, 47, 60	VSS		Power	Digital ground.
3, 17, 40, 59, 80	VDD25		Power	2.5V digital supply.
7, 24, 50, 61, 69	VDD33		Power	3.3V digital supply.
11	PVDD25		Power	Analog 2.5V supply (PLL).
12,14,16	AVSS		Power	Analog ground.
13	RREF		Power	PLL voltage reference. Current source for 2.4k (1%) resistor connected to AVSS.
15	AVDD25		Power	Analog 2.5V supply.

4.3 Detailed Pin Descriptions

4.3.1 DP, DM

DP and DM are the high-speed USB signaling pins, and they should be tied to the D+ and D- pins of the USB connector. Because they operate at high frequencies, the USB signals require special consideration when designing the layout of the PCB. See section 15.0 for PCB layout guidelines.

4.3.2 RSDP, RSDM

RSDP and RSDM are the full-speed USB signaling pins, and they should be tied to the DP and DM pins through 39Ω resistors. RSDP and RSDM also function as current sinks for termination during high-speed operation.

4.3.3 TEST[0:3]

The test pins control the various test modes of the CY7C68310. Most test modes are reserved for ASIC fabrication, but the following table outlines the test modes available for device manufacturing environments. The test pins must be tied to GND for normal operation.

Table 4-1. CY7C68310 Test Modes

Test Mode	Description
0000	Normal Mode. This is the default mode of operation.
0001	Reserved.
0010	Limbo Mode. All output pins set to high-Z during Limbo mode operation with the exception of the XO pin. The XO pin output cell does not have high-Z control (always enabled), and must be disabled or disconnected by other means. To enter Limbo Mode, nRESET must be toggled after the Test pins are set to '0010'.
0011	Input xnorTree Mode. This mode tests the connectivity of all dedicated inputs and outputs. While in the Input xnorTree Mode of operation, all bi-directional pins are wired as chain outputs. The results of the connectivity procedure will be seen on all bidirectional pins. Chain Inputs (in order): VBUSPWRVLD, VBUSPWRD, DISKRDY, ATAIRQ, IORDY, DMARQ, nRESET, ATAEN, DRVPWRVLD, SYSIRQ, nEJECT Chain Outputs (in order): GPIO[2:0], DD[15:0], SDA_nIMODE.
0100	Bi-di xnorTree Mode. This mode test the connectivity of all bi-directional inputs. While in the Bi-di xnor Tree Mode of operation, all bi-directional pins are wired as inputs and become part of the xnor Tree chain. The results of the connectivity procedure will be seen on all output only pins. Chain Inputs: GPIO[0], GPIO[1], GPIO[2], DD[7], DD[8], DD[6], DD[0], DD[5], DD[10], DD[4], DD[11], DD[3], DD[12], DD[2], DD[13], DD[1], DD[14], DD[0], DD[15], SDA_nIMODE. Chain Outputs: nPWR500, nATARST, nDIOW, nDIOR, nDMACK, ATAPUEN, nCS[1:0], DA[2:0], LOWPWR, SCL
0101–1111	Reserved.

4.3.4 XI, XO

The CY7C68310 requires a 30-MHz signal to derive internal timing. Typically a 30-MHz (2.5V tolerant, parallel-resonant fundamental mode) crystal is used, but a 30-MHz (2.5V, 50% duty cycle) square wave from another source can also be used. If a crystal is used, connect the pins to XI and XO, and also through 20pF capacitors to GND as shown in Figure 8-1. If an alternate clock source is used, apply it to XI and leave XO open.

4.3.5 nEJECT

The nEJECT input pin provides a means to communicate an Eject button push to the ATA/ATAPI device via event notification as well as a way to cause a USB Remote-wakeup. During normal operation, asserting nEJECT for 10ms indicates that a media eject has been requested. If the CY7C68310 is in a suspend state, and if remote wakeup is

enabled by the USB host, a state change on this pin will immediately cause the CY7C68310 to perform a USB remote wakeup event.

4.3.6 SYSIRQ

The SYSIRQ pin provides a way for systems to request service from host software by use of the USB Interrupt pipe. If the CY7C68310 has no pending interrupt data to return, USB interrupt pipe data requests are NAKed. If pending data is available, CY7C68310 returns 16 bits of data indicating the state of the DISKRDY pin, the HS_MODE signal (that indicates whether CY7C68310 is operating in high-speed or full-speed), the VBUSPWRD pin, the User-Defined values from bits [7:3] of address 0xE of the configuration space, and the GPIO Pins. *Table 4-2* shows the bitmap for the data returned on the interrupt pipe, and the figure beneath it depicts the latching algorithm incorporated by CY7C68310.

Table 4-2. USB Interrupt Pipe Data Bitmap

USB Interrupt Data Byte 1								USB Interrupt Data Byte 0							
7	6	5	4	3	2	1	0	7	6	5	4	3	2	1	0
0	0	0	0	0	DISKRDY	USB High-Speed	VBUSPWRD	USER_DEF[4]	USER_DEF[3]	USER_DEF[2]	USER_DEF[1]	USER_DEF[0]	GPIO[2]	GPIO[1]	GPIO[0]

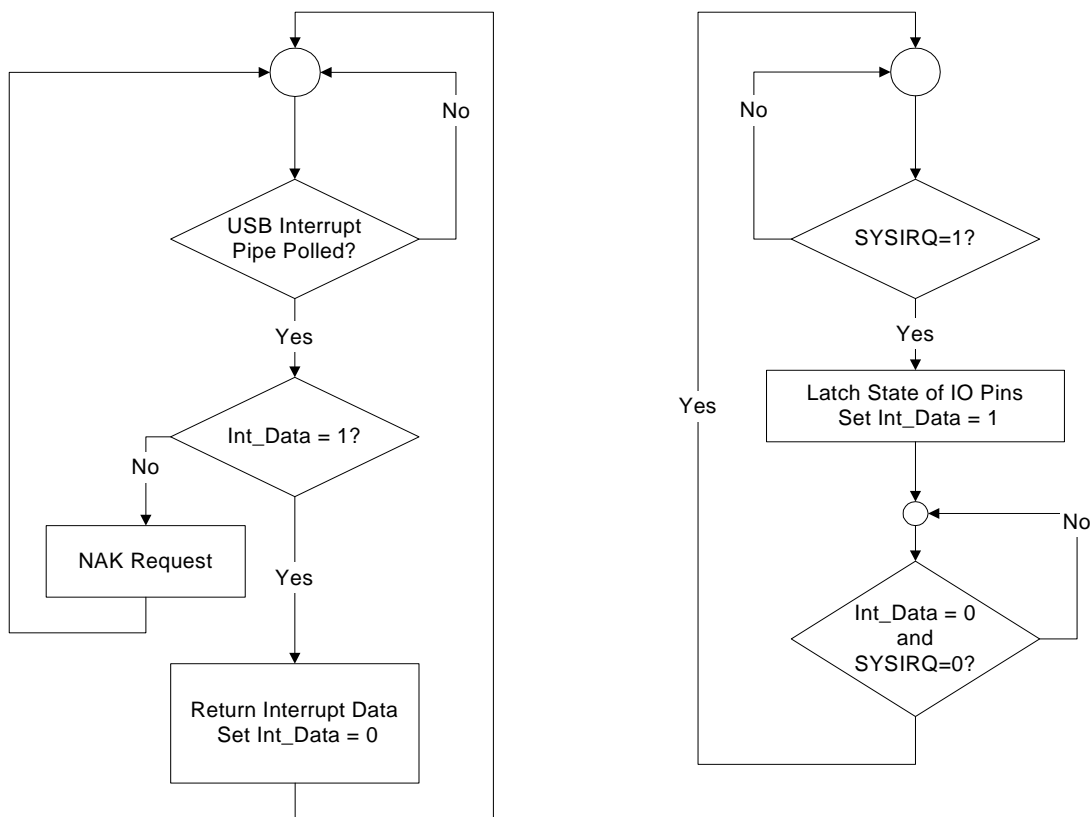
Figure 4-2. SYSIRQ Latching Algorithm

4.3.7 DRVPWRVLD

DRVPWRVLD can be used with removable devices (such as compact flash) to indicate that the media device is present. Pin polarity and function enable are controlled by bits 4 and 2, respectively, of EEPROM address 0x0B. When DRVPWRVLD is deasserted, the CY7C68310 will remove the pull-up on D+ (causing the CY7C68310 to drop off the USB), suspend all ATA state machine activity, drive all ATA interface signals to '0' (assuming ATAEN = '1'), and enter into a low-power state. The CY7C68310 will remain in this state until DRVPWRVLD is asserted, at which time it will enable the D+ pull-up, allow resume of ATA state machine activity, and begin to drive the ATA interface pins (assuming ATAEN = '1').

4.3.8 ATAEN

The ATAEN pin allows ATA bus sharing with other host devices. Deasserting ATAEN causes the CY7C68310 to high-Z all ATA bus interface pins and suspend ATA state machine activity, otherwise leaving the CY7C68310 operational (USB operation continues). Asserting ATAEN causes the CY7C68310 to reset the drive and resume normal operation. To disable USB operation and the ATA interface, the DRVPWRVLD signal can be used in conjunction with ATAEN to force the CY7C68310 into a low-power state until normal operation is resumed. Note that disabling the ATA bus with the ATAEN pin during the middle of a data transfer will result in

data loss and may cause the operating system on the host computer to crash.

4.3.9 GPIO Pins

The GPIO pins allow for a general purpose Input/Output interface. Configuration bytes 0x0E and 0x0F contain the settings for the GPIO pins. See section 6.3 for details of how to use the vendor-specific commands to utilize the GPIO functionality. The status of the GPIO pins is also returned by a USB interrupt event. See section 4.3.6 for SYSIRQ details. Alternatively, if the `hs_indicator` config bit is set (bit 4 of EEPROM address 0x0F), the GPIO2_nHS pin will reflect the operating speed of the device.

4.3.10 LOWPWR

LOWPWR is an output pin that, when in a high-Z state, indicates that the CY7C68310 is in a suspend state. When LOWPWR output is driven '0', the CY7C68310 is active.

4.3.11 nRESET

Asserting nRESET for a minimum of 1 ms after power rails are stable will reset the entire chip. An RC reset circuit should be used that ensures that no spurious resets occur.

4.3.12 ATAPUEN

This output provides control for the required host pull-up resistors on the ATA interface. ATAPUEN is driven '0' when the ATA bus is inactive. ATAPUEN is driven '1' when ATA bus is active. ATAPUEN is set to a high-Z state along with all other ATA interface pins when ATAEN is deasserted.

4.3.13 nPWR500

nPWR500 is an external pin that, when asserted, indicates VBUS current may be drawn up to the limit specified by the `bMaxPower` field of the USB configuration descriptors. nPWR500 will only be asserted if VBUSPWRD is also asserted. If the CY7C68310 enters a low-power state, nPWR500 is deasserted. When normal operation is resumed, nPWR500 is restored accordingly. The nPWR500 pin should never be used to control power sources for the CY7C68310.

4.3.14 SCL, SDA_nIMODE

If an external EEPROM device is used to store configuration information, the clock and data pins for the I²C-compatible port should be connected to the configuration EEPROM and to VCC through 2.2kΩ resistors as shown in Figure 8-1. If configuration information is to be obtained from the attached ATA/ATAPI device (IMODE), SCL should be left as a no-connect and SDA_nIMODE should be tied to GND.

4.3.15 DISKRDY

This input pin indicates the attached device is powered and ready to begin communication with the CY7C68310. DISKRDY polarity can be set using EEPROM address 0x05, bit 0. DISKRDY qualifies the start of the CY7C68310 initialization sequence. A state change from '0' to '1' on DISKRDY will cause the CY7C68310 to wait for 25 ms before asserting nATARESET and re-initializing the device. The ATA interface state machines remain inactive and all of the ATA interface signals are driven logic '0' if DISKRDY is not asserted

(assuming ATAEN = '1'). DISKRDY is filtered for 25 ms on the asserting edge and cleared asynchronously on the deasserting edge.

4.3.16 VBUSPWRD

The VBUSPWRD input pin indicates whether the device will report itself as bus-powered or self-powered. VBUSPWRD also qualifies the use of nPWR500. Based upon the state of this pin at start-up, the CY7C68310 will request the amount of current specified in the `bMaxPower` field of the USB Configuration Descriptor. If VBUSPWRD is asserted, the CY7C68310 will report that the device is bus-powered. If VBUSPWRD is deasserted, the CY7C68310 will report that the device is self-powered.

4.3.17 VBUSPWRVLD

VBUSPWRVLD (USB VBUS Power Valid) indicates that VBUS power is present at the USB connector. VBUSPWRVLD qualifies driving the system's 1.5KΩ pull-up resistor on D+ (the USB specification only allows the device to source power to D+ when the host is powered). VBUSPWRVLD is conditioned so that it is only detected after valid chip configuration bits have been loaded.

5.0 Functional Overview

5.1 USB Signaling Speeds

The CY7C68310 operates at two of the three signal rates that are defined in the Universal Serial Bus Specification Revision 2.0:

- Full-speed, with a signaling bit rate of 12 Mbits/sec.
- High-speed, with a signaling bit rate of 480 Mbits/sec.

5.2 ATA Interface

The ATA/ATAPI port on the CY7C68310 is compliant with the Information Technology–AT Attachment with Packet Interface–6 (ATA/ATAPI-6) Specification, T13/1410D Rev 2a. The CY7C68310 supports both ATAPI packet commands as well as ATA commands (by use of ATA Command Blocks), as outlined in Sections 5.2.1 and 5.2.2. Refer to the USB Mass Storage Class (MSC) Bulk Only Transport Specification for information on Command Block formatting. Additionally, the CY7C68310 translates ATAPI SFF-8070i commands to ATA commands for seamless integration of ATA devices with generic Mass Storage Class BOT drivers. The CY7C68310 also provides a vendor-specific “event notify” ATA command to automatically communicate certain USB and system events to the attached device.

5.2.1 ATA Command Block (ATACB)

The ATA Command Block (ATACB) functionality provides a means of passing ATA commands and ATA register accesses for execution. ATACB commands are transferred in the Command Block Wrapper Command Block (CBWCB) portion of the Command Block Wrapper (CBW). The ATACB is distinguished from other command blocks by the first two bytes of the command block matching the wATACBSignature. Only command blocks that have a valid wATACBSignature are interpreted as ATA Command Blocks. All other fields of the CBW and restrictions on the CBWCB remain as defined in the

USB Mass Storage Class Bulk-Only Transport Specification.
The ATACB must be 16 bytes in length. The following table and text defines the fields of the ATACB.

Table 5-1. ATACB Field Descriptions

Byte	Field Name	Field Description
0	bVSCBSignature	This field indicates to the CY7C68310 that the ATACB contains a vendor-specific command block. This value of this field must match the value in EEPROM address 0x06h for this vendor-specific command to be recognized.
1	bVSCBSubCommand	This field must be set to 0x024h for ATACB commands.
2	bmATACBActionSelect	<p>This field controls the execution of the ATACB according to the bitfield values:</p> <p>Bit 7 <i>IdentifyPacketDevice</i> - This bit indicates that the data phase of the command will contain ATAPI (0xA1h) or ATA (0xECh) IDENTIFY device data. Setting <i>IdentifyPacketDevice</i> when the data phase does not contain IDENTIFY device data will result in unspecified device behavior. 0 = Data phase does not contain IDENTIFY device data 1 = Data phase contains ATAPI or ATA IDENTIFY device data</p> <p>Bit 6 <i>UDMACommand</i> - This bit enables supported UDMA device transfers. Setting this bit when a non-UDMA capable device is attached will result in undetermined behavior. 0 = Do not use UDMA device transfers (only use PIO mode) 1 = Use UDMA device transfers</p> <p>Bit 5 <i>DEVOverride</i> - This bit determines whether the DEV bit value is taken from the CY7C68310 configuration data or from the ATACB. 0 = The DEV bit will be taken from EEPROM address 0x05h, bit 5 1 = The DEV bit will be taken from the ATACB field 0x0B, bit 4</p> <p>Bit 4:3 <i>DPErrOverride</i> - These bits control the Device and Phase Error override feature. These bits shall not be set in conjunction with <i>bmATACBTask-FileRead</i>. 00 = Data accesses are halted if a device or phase error is detected 01 = Data accesses are halted if a device error is detected, but not a phase error 10 = Data accesses are halted if a phase error is detected, but not a device error 11 = Neither device or phase errors will result in halting of data accesses</p> <p>Bit 2 <i>PollAltStatOverride</i> - This bit determines whether or not the Alternate Status register will be polled and the BSY bit will be used to qualify the start of ATACB operation. 0 = The AltStat register will be polled until BSY=0 before proceeding with the ATACB operation 1 = The ATACB operation will be executed without polling the AltStat register</p> <p>Bit 1 <i>DeviceSelectionOverride</i> - This bit determines when the device selection will be performed in relation to the command register write accesses. 0 = Device selection will be performed prior to command register write accesses 1 = Device selection will be performed following command register write accesses</p>

Table 5-1. ATACB Field Descriptions

Byte	Field Name	Field Description
		<p>Bit 0 <i>TaskFileRead</i> - This bit determines whether or not the taskfile register data selected in <i>bmATACBRegisterSelect</i> is returned. If this bit is set, the <i>dCBWDataTransferLength</i> field must be set to 8.</p> <p>0 = Execute ATACB command and data transfer (if any) 1 = Only read taskfile registers selected in <i>bmATACBRegisterSelect</i> and return 0x00h for all others. The format of the 8 bytes of returned data is as follows:</p> <ul style="list-style-type: none"> • Address offset 0x00 (3F6h) - Alternate Status • Address offset 0x01 (1F1h) - Features / Error • Address offset 0x02 (1F2h) - Sector Count • Address offset 0x03 (1F3h) - Sector Number • Address offset 0x04 (1F4h) - Cylinder Low • Address offset 0x05 (1F5h) - Cylinder High • Address offset 0x06 (1F6h) - Device / Head • Address offset 0x07 (1F7h) - Command / Status
3	<i>bmATACBRegisterSelect</i>	<p>This field controls which of the taskfile register read or write accesses occur. Taskfile read data will always be 8 bytes in length, and unselected register data will be returned as 0x00h. Register accesses occur in sequential order as outlined below (0 to 7):</p> <p>Bit 0 (3F6h) Device Control / Alternate Status</p> <p>Bit 1 (1F1h) Features / Error</p> <p>Bit 2 (1F2h) Sector Count</p> <p>Bit 3 (1F3h) Sector Number</p> <p>Bit 4 (1F4h) Cylinder Low</p> <p>Bit 5 (1F5h) Cylinder High</p> <p>Bit 6 (1F6h) Device / Head</p> <p>Bit 7 (1F7h) Command / Status</p>
4	<i>bATACBTransferBlockCount</i>	<p>This value indicates the maximum requested block size in 512-byte increments. This value must be set to the last value used for the "Sectors per block" in the <i>SET_MULTIPLE_MODE</i> command. Legal values are 0, 1, 2, 4, 8, 16, 32, 64, and 128 where 0 indicates 256 sectors per block. A command failed status will be returned if an illegal value is used in the ATACB.</p>
5-12	<i>bATACBTaskFileWriteData</i>	<p>These bytes contain ATA register data used with ATA command or PIO write operations. Only registers selected in <i>bmATACBRegisterSelect</i> are required to hold valid data when accessed. The registers are as follows:</p> <ul style="list-style-type: none"> • ATACB Address Offset 0x05h (3F6h) - Device Control • ATACB Address Offset 0x06h (1F1h) - Features • ATACB Address Offset 0x07h (1F2h) - Sector Count • ATACB Address Offset 0x08h (1F3h) - Sector Number • ATACB Address Offset 0x09h (1F4h) - Cylinder Low • ATACB Address Offset 0x0Ah (1F5h) - Cylinder High • ATACB Address Offset 0x0Bh (1F6h) - Device • ATACB Address Offset 0x0Ch (1F7h) - Command
13-15	Reserved	These bytes must be set to 0x00h for ATACB commands.

5.2.2 ATA Command Block 2 (ATACB2)

The ATA Command Block 2 (ATACB2) functionality provides a means of passing ATA commands and ATA register accesses for execution. ATACB2 allows for 48-bit commands. ATACB2 commands are transferred in the CBWCB portion of the CBW. The ATACB2 is distinguished from other command blocks by the first two bytes of the command block matching the

wATACB2Signature. Only command blocks that have a valid wATACB2Signature are interpreted as ATACB2 commands. All other fields of the CBW and restrictions on the CBWCB shall remain as defined in the USB Mass Storage Class Bulk-Only Transport Specification. The ATACB2 must be 16 bytes in length. The following table and text defines the fields of the ATACB2.

Table 5-2. ATACB2 Field Descriptions

Byte	Field Name	Field Description
0	bVSCBSignature	This field indicates to the CY7C68310 that the ATACB contains a vendor-specific command block. This value of this field must match the value in EEPROM address 0x06h for this vendor-specific command to be recognized.
1	bVSCBSubCommand	This field must be set to 0x025h for ATACB2 commands.
2	bmATACB2RegisterSelect	This field controls which of the taskfile register read or write accesses occur. Taskfile read data will always be 12 bytes in length, and unselected register data will be returned as 0x00h. Register accesses occur in sequential order as outlined below (0 to 7):
		Bit 0 (3F6h) - Alternate Status (read only, unaffected by write commands)
		Bit 1 (1F1h) - Features / Error
		Bit 2 (1F2h) - Sector Count
		Bit 3 (1F3h) - LBA Low (Sector Number)
		Bit 4 (1F4h) - LBA Mid (Cylinder Low)
		Bit 5 (1F5h) - LBA High (Cylinder High)
		Bit 6 (1F6h) - Device / Head (see bmATACB2ActionSelect1)
3	bmATACB2ActionSelect1	This field controls the execution of the ATACB2 according to the bitfield values:
		Bit 7 <i>IdentifyDevice</i> - This bit indicates that the data phase of the command will contain ATAPI (0xA1h) or ATA (0xECh) IDENTIFY device data. Setting IdentifyDevice when the data phase does not contain IDENTIFY device data will result in undetermined device behavior. 0 = Data phase does not contain IDENTIFY device data 1 = Data phase contains ATAPI or ATA IDENTIFY device data
		Bit 6 <i>UDMACommand</i> - This bit enables supported UDMA device transfers. Setting this bit when a non-UDMA capable device is attached will result in undetermined behavior. 0 = Do not use UDMA device transfers (only use PIO mode) 1 = Use UDMA device transfers
		Bit 5 <i>DEVOverride</i> - This bit determines whether the DEV bit value is taken from the CY7C68310 configuration data or from the ATACB2. 0 = The DEV bit will be taken from EEPROM address 0x05h, bit 5 1 = The DEV bit will be taken from bATACB2DeviceHeadData[5]
		Bit 4 <i>DErrorOverride</i> - This bit controls the device error override feature. This bit should not be set during a bmATACB2ActionSelect TaskFileRead. 0 = Data accesses are halted if a device error is detected 1 = Data accesses are not halted if a device error is detected
		Bit 3 <i>PErrorOverride</i> - This bit controls the phase error override feature. This bit should not be set during a bmATACB2ActionSelect TaskFileRead. 0 = Data accesses are halted if a phase error is detected 1 = Data accesses are not halted if a phase error is detected
		Bit 2 <i>PollAltStatOverride</i> - This bit determines whether or not the Alternate Status register will be polled and its BSY bit will be used to qualify the start of ATACB operation. 0 = The AltStat register will be polled until BSY=0 before proceeding with the ATACB operation 1 = The ATACB operation will be executed without polling the AltStat register

Table 5-2. ATACB2 Field Descriptions

Byte	Field Name	Field Description
		<p>Bit 1 <i>DeviceSelectionOverride</i> - This bit determines when the device selection will be performed in relation to the command register write accesses. 0 = Device selection will be performed prior to command register accesses 1 = Device selection will be performed following command register accesses</p> <p>Bit 0 <i>TaskFileRead</i> - This bit determines whether or not the taskfile register data selected in <i>bmATACB2RegisterSelect</i> is returned. If this bit is set, the <i>dCBWDataTransferLength</i> field must be set to 12. 0 = Execute ATACB2 command and data transfer (if any) 1 = Only read taskfile registers selected in <i>bmATACBRegisterSelect</i> and return 0x00h for all others. The format of the 12 bytes of returned data is as follows:</p> <ul style="list-style-type: none"> • Address offset 0x00h (3F6h) Alternate Status (HOB=0) • Address offset 0x01h (1F6h) Device / Head (HOB=0) • Address offset 0x02h (1F1h) Error (HOB=0) • Address offset 0x03h (1F2h-M) Sector Count (HOB=1) • Address offset 0x04h (1F3h-M) LBA Low (Sector Number) (HOB=1) • Address offset 0x05h (1F4h-M) LBA Mid (Cylinder Low) (HOB=1) • Address offset 0x06h (1F5h-M) LBA High (Cylinder High) (HOB=1) • Address offset 0x07h (1F2h-L) Sector Count (HOB=0) • Address offset 0x08h (1F3h-L) LBA Low (HOB=0) • Address offset 0x09h (1F4h-L) LBA Mid (HOB=0) • Address offset 0x0Ah (1F5h-L) LBA High (HOB=0) • Address offset 0x0Bh (1F7h) Status (HOB=0)
4	<i>bATACB2TransferBlockCount</i> [7:4]	These bits indicate the DRQ block size in 512-byte increments. This value is log base 2 of the block size. Legal values are 0 (1 sector per block) through 8 (256 sectors per block). A command failed status will be returned if an illegal value is used in the ATACB2. For commands using multiple sector PIO data transfers, the number of sectors per block must equal the current Multiple Sector Setting of the drive. These bits should be set to '0' for non-multiple, non-UDMA commands.
	<i>bmATACB2ActionSelect</i> 2[3:0]	<p>This field controls the execution of the ATACB according to the bitfield values:</p> <p>Bits 3-1 <i>Reserved</i> - These bits must be set to '0'</p> <p>Bit 0 <i>48-bit-write</i> - Determines whether or not M data is used to read 1F2-1F5 0 = Do not read or write 1F2-1F5 with "-M" data 1 = Read or write 1F2-1F5 with "-M" data</p>
5	<i>bATACB2DeviceHeadData</i>	The contents of this field are used for writing the Device Head register when Byte 2, Bit 6 of the ATACB2 is set to '1'. Otherwise, the value written will be determined by the bridge.
		Bits 7-5 <i>DevHead</i> - Data used to write to Device Head register.
		Bit 4 <i>DEVOverride</i> - This bit reflects the state of Byte 3, Bit 5 of the ATACB2.
		Bits 3-0 <i>DevHead</i> - Data used to write to Device head register.
6-15	<i>bATACB2TaskFileWriteData</i>	<p>These bytes contain ATA register data used with ATA command or PIO write operations. Only registers selected in <i>bmATACB2RegisterSelect</i> are required to hold valid data when accessed. The registers are as follows:</p> <ul style="list-style-type: none"> • ATACB2 Address offset 6h (1F1h) Features • ATACB2 Address offset 7h (1F2h-M) Sector Count • ATACB2 Address offset 8h (1F3h-M) LBA Low (Sector Number) • ATACB2 Address offset 9h(1F4h-M) LBA Mid (Cylinder Low) • ATACB2 Address offset Ah (1F5h-M) LBA High (Cylinder High) • ATACB2 Address offset Bh (1F2h-L) Sector Count • ATACB2 Address offset Ch (1F3h-L) LBA Low • ATACB2 Address offset Dh (1F4h-L) LBA Mid • ATACB2 Address offset Eh (1F5h-L) LBA High • ATACB2 Address offset Fh (1F7h) Command

5.2.3 Vendor-specific EVENT_NOTIFY Command

The vendor-specific EVENT_NOTIFY command enables the CY7C68310 to communicate the occurrence of certain USB and system events to the attached device if the device's

firmware supports the EVENT_NOTIFY command. The command code is specified by configuration address 0x02. Setting this byte to 0x00 disables the EVENT_NOTIFY feature.

Table 5-3. Notification Register Read Values

Register	7	6	5	4	3	2	1	0
Error	N/A							
Sector Count	N/A							
LBA Low (Sector Number)	N/A							
LBA Mid (Cylinder Low)	nSTATE0							
LBA High (Cylinder High)	nSTATE1							
Device/Head	N/A							
Status	BUSY	N/A	N/A	N/A	DRQ	N/A	N/A	N/A

The nSTATE0 and nSTATE1 values are read from the device and stored for use as the STATE0 and STATE1 values during the next execution of the event notification command. The nSTATE0 and nSTATE1 values provide temporary non-volatile storage for devices whose power is controlled by nPWR500 (typically bus-powered systems). This allows the device to

store information prior to entering a USB Suspend state for retrieval after resuming from the USB Suspend state. Note that a USB Reset from the host may interrupt the collection of data. The device must accommodate the potential for this occurrence. The BSY and DRQ bits must be cleared by the device upon the completion of an event notification command.

Table 5-4. Notification Register Write Values

Register	7	6	5	4	3	2	1	0
Features	USB Reset	Class Specific Reset	USB Suspend	USB Resume	Reserved	Reserved	Eject Button Pressed	Eject Button Released
Sector Count	Reserved	Reserved	Reserved	Reserved	Self-Powered	Bus-Powered	USB High-Speed	USB Full-Speed
LBA Low (Sector Number)	N/A							
LBA Mid (Cylinder Low)	STATE0							
LBA High (Cylinder High)	STATE1							
Device/Head	N/A							
Command	Specified in Configuration byte 0x02							

The STATE0 and STATE1 values are written with the value of nSTATE0 and nSTATE1 obtained from the previously completed event notification command. Assertion of nRESET resets STATE0 and STATE1 to 0x00.

ration data should not be confused with the USB Configuration Descriptor data.

6.0 Configuration

Certain timing parameters and operational modes for the CY7C68310 are configurable. Some USB configuration and descriptor values are also configurable. CY7C68310 configu-

6.1 CY7C68310 Configuration and USB Descriptor Sources

CY7C68310 configuration and USB descriptor data can be retrieved from three sources. *Table 6-1* indicates the method of determining which data source is used.

Table 6-1. CY7C68310 Configuration and USB Descriptor Sources

SDA_nIMODE = 0	I ² C-compatible Device Present	I ² C Signature Check Passes	CY7C68310 Configuration and USB Descriptor Retrieval Method
No	No	N/A	In this mode, the CY7C68310 uses internal ROM contents for USB descriptor information and configuration register values. This mode is for debug/manufacturing operation only. Not for shipping products.
Yes	N/A	No	In this mode, the CY7C68310 uses internal ROM contents for USB descriptor information. Configuration register values are loaded from internal ROM. This is not a valid mode of operation.
Yes	N/A	Yes	The CY7C68310 retrieves all Descriptor and Configuration values from the vendor-specific Identify (FBh) data. The CY7C68310 is configured using internal ROM values until FBh data becomes available.
No	Yes	No	The CY7C68310 uses internal ROM contents for USB descriptor information. Configuration register values are loaded from internal ROM. In this mode of operation, any CY7C68310 vendor-specific configuration access causes the CY7C68310 to recheck the signature field. Once the signature check passes, SROM data is returned for USB descriptors requests. This is not a valid mode of operation.
No	Yes	Yes	The CY7C68310 retrieves all Descriptor and Configuration values from the I ² C-compatible memory device. The CY7C68310 is configured using these values.

6.1.1 I²C-compatible Device

The CY7C68310 provides support for the 24LCXXB family of EEPROMs. Following the release of nRESET, the CY7C68310 waits 50 ms and then checks for I²C-compatible device presence. If an I²C-compatible device is present but does not pass signature check, the CY7C68310 re-tests the signature with each vendor-specific USB load or read access of configuration bytes 0 and 1. Once the signature check passes, I²C-compatible data is returned for USB descriptor requests. If an I²C-compatible device is detected initially, it is always assumed present until the next reset cycle (nRESET). If an I²C-compatible device is present, a lack of an ACK response when required causes the CY7C68310 to stall that USB request. The CY7C68310 will attempt the access again with the next USB request.

6.1.2 IMODE

Configuration and descriptor data can also be supplied by an attached mass storage device (IMODE) through a vendor-specific Identify (FBh) ATA command. The CY7C68310 provides 256 bytes of internal RAM for FBh data storage. Unlike operation with an external I²C-compatible memory device, IMODE operation requires the attached device first be initialized and FBh data retrieved before the CY7C68310 can allow USB enumeration. To meet USB specification requirements, IMODE operation must be limited to systems that draw 100 mA or less from VBUS prior to USB configuration.

6.1.3 Internal ROM Contents

The CY7C68310 also contains an internal set of CY7C68310 configuration and USB descriptors. The internal descriptors may only be used during manufacturing, as the internal ROM values disable some features required for normal operation to aid use in a manufacturing environment. Also, the internal ROM descriptors do not provide a unique serial number (required for USB Mass Storage Class compliance), and therefore cannot be used for shipping products. See *Table 6-2* for the organization of the internal ROM contents. An external I²C-compatible memory device or utilization of the vendor-specific FBh identify command is required to correctly configure the CY7C68310 for operation and provide a unique serial number for MSC compliance.

6.2 EEPROM Organization

CY7C68310 configuration and USB descriptor data can be supplied from an I²C-compatible serial memory device. The CY7C68310 can address 2 Kbytes of I²C-compatible data, but CY7C68310 configuration and USB descriptor information are limited to 512 bytes maximum. Unused register space in the I²C-compatible serial memory device may be used for product specific data storage. Note that no descriptor is allowed to span multiple pages within the I²C-compatible serial memory device.

Table 6-2. EEPROM Organization

I ² C Address	Field Name	Field Description	Required I ² C Data	Example I ² C Data
CY7C68310 Configuration Data				
0x00	I ² C memory device Signature (LSB)	LSB I ² C memory device Signature byte.	0x4B	
0x01	I ² C memory device Signature (MSB)	MSB I ² C memory device Signature byte.	0x50	
0x02	Event Notification	Bits (7:0) ATAPI event notification command. The value of this register (if other than 0x00) is used to identify the vendor-specific Event Notification command (see Section 5.2.3). Setting this field to 0x00 disables this feature.		0x00
0x03	APM Value	Bits (7:0) ATA device Automatic Power Management value. If an attached ATA device supports APM and this field contains other than 0x00, the CY7C68310 will issue a SET FEATURES command to enable APM with this register value during the drive initialization.		0x00
0x04	ATA Initialization Timeout	Time in 128-millisecond granularity before the CY7C68310 stops polling the ALT STAT register for reset complete and restarts the reset process (0x80 = 16.4 seconds).		0x80
0x05	USB Bus Mode	Bit (7) – Read only USB bus mode of operation. '0' = USB is operating in full-speed mode (12 Mbit/sec) '1' = USB is operating in high-speed mode (480 Mbit/sec)		0x00
	ATAPI Command Block Size	Bit (6) CBW Command Block Size. '0' = 12 byte ATAPI CB '1' = 16 byte ATAPI CB		
	Master/Slave Selection	Bit (5) Device number selection. This bit is valid only when "Skip ATA/ATAPI Device Initialization" is active. Otherwise, the value of this bit is ignored. '0' = Drive 0 (master) '1' = Drive 1 (slave)		
	ATAPI Reset	Bit (4) ATAPI reset during drive initialization. Setting this bit causes the CY7C68310 to issue an ATAPI reset during device initialization.		
	ATA_NATAPI	Bit (3) – Read only. Indicates if an ATA or ATAPI device is detected. '0' = ATAPI device '1' = ATA device or possible device initialization failure		
	Force USB FS	Bit(2) Force USB full-speed only operation. Setting this bit prevents the CY7C68310 from negotiating HS operation during USB reset events. '0' = Normal operation – allow HS negotiation during USB reset		

Table 6-2. EEPROM Organization (continued)

I ² C Address	Field Name	Field Description	Required I ² C Data	Example I ² C Data
		'1' = USB FS only – do not allow HS negotiation during USB reset		
	VS/MSC SOFT_RESET	Bit(1) Vendor-specific/MSC SOFT_RESET control. '0' = Vendor-specific USB command utilized for SOFT_RESET '1' = Mass Storage Class USB command utilized for SOFT_RESET		
	DISKRDY Polarity	Bit (0) DISKRDY active polarity. DISKRDY Polarity is ignored if IMODE is set to '1'. During IMODE operation DISKRDY polarity is active HIGH. '0' = Active HIGH polarity '1' = Active LOW polarity		
0x06	ATA Command Designator	Value in CBW CB field that designates if the CB is decoded as vendor-specific ATA/CFG commands instead of the ATAPI command block.		0x24
0x07	Reserved	Bits (7:1)– must be set to '0'.		0x01
	Retry ATAPI	Bit (0) This bit enables the CY7C68310 to accommodate ATAPI devices that take longer to initialize than what is allowed in the ATA/ATAPI-6 specification. '1' = Retry ATAPI commands '0' = Normal ATAPI timing		
0x08	Initialization Status	Bit (7) – Read only Drive Initialization Status. If set, indicates the drive initialization sequence state machine is active.		0x00
	Force ATA Device	Bit (6) Allows software to manually enable ATA Translation with devices that do not support CY7C68310 device initialization algorithms. Force ATA Device must be set to '1' in conjunction with Skip ATA/ATAPI Device Initialization and ATA Translation Enable.		
	Skip ATA/ATAPI Device Initialization	Bit (5) Forces the CY7C68310 to skip device initialization upon startup. This bit should be cleared for IMODE operation. The USB device driver must initialize the attached device (if required) when this bit is set. For ATAPI devices, the host driver must issue an IDENTIFY command utilizing ATA. '0' = normal operation '1' = only reset the device and write the device control register prior to processing commands		
	Reserved	Bits (4:3) – must be set to '0'.		
	Last LUN Identifier	Bits (2:0) Maximum number of LUNs device supports.		
0x09	ATAEN	Bit (7) – Read only. Holds the current logic state of the ATAEN pin.		0x01

Table 6-2. EEPROM Organization (continued)

I ² C Address	Field Name	Field Description	Required I ² C Data	Example I ² C Data
	Reserved	Bits (6:1) – must be set to '0'.		
	SRST Enable	Bit (0) Soft-reset during drive initialization. '0' = Disable soft-reset functionality '1' = Enable soft-reset during drive initialization		
0x0A	ATA Data Assert	Bits (7:4) ATA cycle times are calculated using Data Assert and Data Recover values. Standard values for ATA-compliant devices and a 30.0-MHz system clock (in binary): mode 0 0101 (5+1)*33.33 = 200 ns mode 1 0011 (3+1)*33.33 = 133 ns mode 2 0011 (3+1)*33.33 = 133 ns mode 3 0010 (2+1)*33.33 = 100 ns mode 4 0010 (2+1)*33.33 = 100 ns		0x20
	ATA Data Recover	Bits (3:0) Standard recover values and cycle times for ATA-compliant devices and a 30.0 MHz system clock (in binary): mode 0 1100 (4+1)+(12+1)*33.33 = 600 ns mode 1 0111 (3+1)+(7+1)*33.33 = 400 ns mode 2 0011 (2+1)+(3+1)*33.33 = 233 ns mode 3 0010 (2+1)+(2+1)*33.33 = 200 ns mode 4 0000 (2+1)+(0+1)*33.33 = 133 ns		
0x0B	ATA Data Set-up	Bits (7:5) Set-up time is only incurred on the first data cycle of a burst. Standard values for ATA-compliant devices and a 30.0 MHz system clock are (in binary): mode 0 010 (2+1)*33.33 = 133 ns mode 1 001 (1+1)*33.33 = 66 ns mode 2 001 (1+1)*33.33 = 66 ns mode 3 001 (1+1)*33.33 = 66 ns mode 4 000 (0+1)*33.33 = 33 ns		0x00
	Drive Power Valid Polarity	Bit (4) Controls the polarity of DRVPWRVLD pin. '0' = Active LOW ("connector ground" indication) '1' = Active HIGH (power indication from device)		
	Override PIO Timing	Bit (3) This field is used in conjunction with ATA Data Set-up, ATA Data Assertion, ATA Data Recover, and PIO Mode Selection fields. '0' = Use timing information acquired from the Drive '1' = Override device timing information with configuration values		
	Drive Power Valid Enable	Bit (2)		

Table 6-2. EEPROM Organization (continued)

I ² C Address	Field Name	Field Description	Required I ² C Data	Example I ² C Data
		Enable for the DRVPWRVLD pin. DRVPWRVLD is typically only be enabled in applications where the CY7C68310 is VBUS powered. '0' = pin disabled (most systems) '1' = pin enabled		
	ATA Read Kludge	Bit(1) PIO data read high-Z control. Enabling this will high-Z the ATA data bus during PIO read operations while addressing the data register. In most applications this bit is set to '0.' '0' = Normal operation as per ATA/ATAPI interface specification '1' = High-Z DD[15:0] during PIO data register reads		
	IMODE	Bit (0) – Read only This bit reflects the state of the IMODE input pin at start-up.		
0x0C	SYSIRQ	Bits(7) – Read only This bit reflects the current logic state of the SYSIRQ input.		0x3C
	DISKRDY	Bit(6) – Read only This bit reflects the current logic state of the DISKRDY input.		
	ATA Translation Enable	Bit(5) Enable ATAPI to ATA protocol translation enable. If enabled, AND if an ATA device is detected, ATA translation is enabled. If Skip ATA/ATAPI Device Initialization is set '1,' Force ATA Device must also be set '1' in order to utilize ATA translation. '0' = ATA Translation Disabled '1' = ATA Translation Enable		
	ATA UDMA Enable	Bit(4) Enable Ultra Mode data transfer support for ATA devices. If enabled, AND the ATA device reports UDMA support, the CY7C68310 will utilize UDMA data transfers. '0' = Disable ATA device UDMA support '1' = Enable ATA device UDMA support		
	ATAPI UDMA Enable	Bit(3) Enable Ultra Mode data transfer support for ATAPI devices. If enabled, AND the ATAPI device reports UDMA support, the CY7C68310 will utilize UDMA data transfers. '0' = Disable ATAPI device UDMA support '1' = Enable ATAPI device UDMA support		
	ROM UDMA Mode	Bits(2:0) ROM UDMA Mode indicates the highest UDMA mode supported by the product. The CY7C68310 will utilize the lesser of ROM UDMA Mode and the highest mode supported by the device. UDMA read operation mode timing is controlled by the device. mode 0 000 133.3 ns per 16-bit word write mode 1 001 100 ns per 16-bit word write mode 2 010 66.7 ns per 16-bit word write mode 3 011 66.7 ns per 16-bit word write mode 4 100 33.3 ns per 16-bit word write		

Table 6-2. EEPROM Organization (continued)

I ² C Address	Field Name	Field Description	Required I ² C Data	Example I ² C Data
0x0D	PIO Mode Selection	Bits (7:5) PIO Mode Selection. The PIO mode reported back to the device if the Override PIO Timing configuration bit is set.		0x90
		mode 0 000 mode 1 001 mode 2 010 mode 3 011 mode 4 100		
	Skip Pin Reset	Bit (4) Skip nATARST assertion. Setting this bit prevents the CY7C68310 from asserting nATARST during initialization of the ATA/ATAPI device. If this bit is set to '1', SRST Enable (address 0x09, bit 0) must also be set to '1'. '0' = Allow nATARST assertion '1' = Disable nATARST assertion		
	Reserved	Bits (3:0) – must be set to '0'.		
0x0E	SYSIRQ User-defined Bits	Bits (7:3) SYSIRQ USER_DEF[4:0] bits. The value of these bits will be returned to the host via the USB interrupt pipe as stated in Section 4.3.6.		0x00
	General Purpose IO	Bits(2:0) GPIO[2:0] pin values. When the GPIO pins are configured as outputs, writing to these bits will set the logic value of the GPIO pins to '0' or '1'. Reading this address, regardless of whether the GPIO pins are set to input or output, returns the logic value from the GPIO pins.		
0x0F	ATAPI IRQ Disable	Bit (7) Disables the use of the ATAIRQ signal with ATAPI devices. '0' = ATAIRQ use enabled '1' = ATAIRQ use disabled		0x07
	Reserved	Bit (6) – must be set to '0'.		
	Int Reason Disable	Bit (5) Setting to a '1' causes CY7C68310 to ignore the contents of the interrupt reason register when talking to an ATAPI device.		
	HS Indicator Enable	Bit (4) Enables GPIO2_nHS pin to indicate the current operating speed of the device (if output is enabled). '0' = normal GPIO operation '1' = high-speed indicator enable		
	Reserved	Bit (3) – must be set to '1'.		
	General Purpose IO Pin Enable	Bits (2:0) GPIO[2:0] high-Z control. These bits have precedence over bit 4 of this byte. '0' = Output enabled (GPIO pin is an output). '1' = high-Z (GPIO pin is an input).		

Table 6-2. EEPROM Organization (continued)

I²C Address	Field Name	Field Description	Required I²C Data	Example I²C Data
USB Device Descriptor				
0x10	bLength	Length of device descriptor in bytes.	0x12	
0x11	bDescriptor Type	Descriptor type for device descriptor.	0x01	
0x12	bcdUSB (LSB)	USB Specification release number in BCD.	0x00	
0x13	bcdUSB (MSB)		0x02	
0x14	bDeviceClass	Device class.		0x00
0x15	bDeviceSubClass	Device subclass.		0x00
0x16	bDeviceProtocol	Device protocol.		0x00
0x17	bMaxPacketSize0	Maximum USB packet size supported.	0x40	
0x18	idVendor (LSB)	Vendor ID.		0xB4
0x19	idVendor (MSB)			0x04
0x1A	idProduct (LSB)	Product ID.		0x31
0x1B	idProduct (MSB)			0x68
0x1C	bcdDevice (LSB)	Device release number in BCD lsb (product release number).		0x00
0x1D	bcdDevice (MSB)	Device release number in BCD msb (silicon release number). This field entry is always returned from internal ROM contents, regardless of the descriptor source.		0x01
0x1E	iManufacturer	Index to manufacturer string. This entry must equal half of the address value where the string starts or 0 if the string does not exist.		0x49
0x1F	iProduct	Index to product string. This entry must equal half of the address value where the string starts or 0 if the string does not exist.		0x5F
0x20	iSerialNumber	Index to serial number string. This entry must equal half of the address value where the string starts or 0 if the string does not exist. The USB Mass Storage Class Bulk Only Transport Specification requires a unique serial number.		0x73
0x21	bNumConfigurations	Number of configurations supported.	0x01	
USB Device Qualifier Descriptor				
0x22	bLength	Length of device descriptor in bytes.	0x0A	
0x23	bDescriptorType	Descriptor type.	0x06	
0x24	bcdUSB (LSB)	USB specification release number in BCD.		0x00
0x25	bcdUSB (MSB)			0x02
0x26	bDeviceClass	Device class.		0x00
0x27	bDeviceSubClass	Device subclass.		0x00
0x28	bDeviceProtocol	Device protocol.		0x00
0x29	bMaxPacketSize0	Maximum USB packet size supported.	0x40	
0x2A	bNumConfigurations	Number of configurations supported.	0x01	
0x2B	bReserved	Reserved. Must be set to 0.	0x00	
USB Standard Configuration Descriptor (VBUSPWRD Asserted)				
0x2C	bLength	Length of Configuration descriptor in bytes.	0x09	
0x2D	bDescriptorType	Descriptor type.	0x02	
0x2E	bTotalLength (LSB)	Number of bytes returned in this configuration. This includes the configuration descriptor plus all the interface and endpoint descriptors.	0x27	
0x2F	bTotalLength (MSB)		0x00	

Table 6-2. EEPROM Organization (continued)

I ² C Address	Field Name	Field Description	Required I ² C Data	Example I ² C Data
0x30	bNumInterfaces	Number of interfaces supported. The CY7C68310 only supports one interface.	0x01	
0x31	bConfiguration Value	The value to use as an argument to Set Configuration to select the configuration. This value must be set to 0x02.	0x02	
0x32	iConfiguration	Index to the configuration string. This entry must equal half of the address value where the string starts or 0x00 if the string does not exist.		0x00
0x33	bmAttributes	Device attributes for this configuration. Configuration characteristics: Bit Description On board default 7 Reserved. Set to '1' '1' 6 Self powered '0' = Bus-powered device 5 Remote wake-up '0' 4:0 Reserved. Set to '0' '0'	0x80 or 0xA0	
0x34	bMaxPower	Maximum power consumption for this configuration. Units used are mA*2 (i.e., 0x31 = 98 mA, 0xF9 = 498 mA).		0xF9
USB Other Speed Configuration Descriptor (VBUSPWRD Asserted)				
0x35	bLength	Length of Configuration descriptor in bytes.	0x09	
0x36	bDescriptorType	Descriptor type.	0x07	
0x37	bTotalLength (LSB)	Number of bytes returned in this configuration. This includes the configuration descriptor plus all the interface and endpoint descriptors.	0x27	
0x38	bTotalLength (MSB)		0x00	
0x39	bNumInterfaces	Number of interfaces supported. The CY7C68310 only supports one interface.	0x01	
0x3A	bConfigurationValue	The value to use as an argument to Set Configuration to select the configuration. This value must be set to 0x02.	0x02	
0x3B	iConfiguration	Index to the configuration string. This entry must equal half of the address value where the string starts or 0x00 if the string does not exist.		0x00
0x3C	bmAttributes	Device attributes for this configuration. Configuration characteristics: Bit Description On board default 7 Reserved. Set to '1' '1' 6 Self powered '0' = Bus-powered device 5 Remote wake-up '0' 4:0 Reserved. Set to '0' '0'	0x80 or 0xA0	
0x3D	bMaxPower	Maximum power consumption for this configuration. Units used are mA*2 (i.e., 0x31 = 98 mA, 0xF9 = 498 mA).		0xF9
USB Interface Descriptor (High-speed)				
0x3E	bLength	Length of interface descriptor in bytes.	0x09	
0x3F	bDescriptorType	Descriptor type.	0x04	
0x40	bInterfaceNumber	Interface number.	0x00	
0x41	bAlternateSettings	Alternate settings.	0x00	
0x42	bNumEndpoints	Number of endpoints.	0x03	
0x43	bInterfaceClass	Interface class.		0x08
0x44	bInterfaceSubClass	Interface subclass.		0x06
0x45	bInterfaceProtocol	Interface protocol.		0x50
0x46	iInterface	Index to first interface string. This entry must equal half of the address value where the string starts or zero if the string does not exist.		0x00

Table 6-2. EEPROM Organization (continued)

I ² C Address	Field Name	Field Description	Required I ² C Data	Example I ² C Data
USB Bulk Out Endpoint (High-speed)				
0x47	bLength	Length of this descriptor in bytes.	0x07	
0x48	bDescriptorType	Endpoint descriptor type.	0x05	
0x49	bEndpointAddress	This is an Out endpoint, endpoint number 1.	0x01	
0x4A	bmAttributes	This is a bulk endpoint.	0x02	
0x4B	wMaxPacketSize (LSB)	Max data transfer size.	0x00	
0x4C	wMaxPacketSize (MSB)		0x02	
0x4D	bInterval	High-speed interval for polling (max NAK rate).	0x01	
USB Bulk In Endpoint (High-speed)				
0x4E	bLength	Length of this descriptor in bytes.	0x07	
0x4F	bDescriptorType	Endpoint descriptor type.	0x05	
0x50	bEndpointAddress	This is an In endpoint, endpoint number 2.	0x82	
0x51	bmAttributes	This is a bulk endpoint.	0x02	
0x52	wMaxPacketSize (LSB)	Max data transfer size.	0x00	
0x53	wMaxPacketSize (MSB)		0x02	
0x54	bInterval	High-speed interval for polling (max NAK rate).	0x01	
USB Interrupt Endpoint (High-speed)				
0x55	bLength	Length of this descriptor in bytes.	0x07	
0x56	bDescriptorType	Endpoint descriptor type.	0x05	
0x57	bEndpointAddress	This is an In endpoint, endpoint number 3.	0x83	
0x58	bmAttributes	This is an interrupt endpoint.	0x03	
0x59	wMaxPacketSize (LSB)	Max data transfer size.	0x02	
0x5A	wMaxPacketSize (MSB)		0x00	
0x5B	bInterval	High-speed interval for polling (max NAK rate).	0x0C	
0x5C	Reserved	Reserved.	0x00	
USB Interface Descriptor (Full-speed)				
0x5D	bLength	Length of interface descriptor in bytes.	0x09	
0x5E	bDescriptorType	Descriptor type.	0x04	
0x5F	bInterfaceNumber	Interface number.	0x00	
0x60	bAlternateSettings	Alternate settings	0x00	
0x61	bNumEndpoints	Number of endpoints.	0x03	
0x62	bInterfaceClass	Interface class.		0x08
0x63	bInterfaceSubClass	Interface subclass.		0x06
0x64	bInterfaceProtocol	Interface protocol.		0x50
0x65	iInterface	Index to first interface string. This entry must equal half of the address value where the string starts or zero if the string does not exist.		0x00
USB Bulk Out Endpoint (Full-speed)				
0x66	bLength	Length of this descriptor in bytes.	0x07	
0x67	bDescriptorType	Endpoint descriptor type.	0x05	
0x68	bEndpointAddress	This is an Out endpoint, endpoint number 1.	0x01	
0x69	bmAttributes	This is a bulk endpoint.	0x02	
0x6A	wMaxPacketSize (LSB)	Max data transfer size.	0x40	
0x6B	wMaxPacketSize (MSB)		0x00	

Table 6-2. EEPROM Organization (continued)

I ² C Address	Field Name	Field Description	Required I ² C Data	Example I ² C Data															
0x6C	bInterval	High-speed interval for polling (max NAK rate). Does not apply to FS bulk endpoints, set to zero.	0x00																
USB Bulk In Endpoint (Full-speed)																			
0x6D	bLength	Length of this descriptor in bytes.	0x07																
0x6E	bDescriptorType	Endpoint descriptor type.	0x05																
0x6F	bEndpointAddress	This is an In endpoint, endpoint number 2.	0x82																
0x70	bmAttributes	This is a bulk endpoint.	0x02																
0x71	wMaxPacketSize (LSB)	Max data transfer size.	0x40																
0x72	wMaxPacketSize (MSB)		0x00																
0x73	bInterval	High-speed interval for polling (max NAK rate). Does not apply to FS bulk endpoints, set to zero.	0x00																
USB Interrupt Endpoint (Full-speed)																			
0x74	bLength	Length of this descriptor in bytes.	0x07																
0x75	bDescriptorType	Endpoint descriptor type.	0x05																
0x76	bEndpointAddress	This is an In endpoint, endpoint number 3.	0x83																
0x77	bmAttributes	This is an interrupt endpoint.	0x03																
0x78	wMaxPacketSize (LSB)	Max data transfer size.	0x02																
0x79	wMaxPacketSize (MSB)		0x00																
0x7A	bInterval	High-speed interval for polling (max NAK rate).	0xFF																
0x7B	Reserved	Reserved.	0x00																
USB String Descriptor – Index 0 (LANGID)																			
0x7C	bLength	LANGID descriptor length.	0x04																
0x7D	bDescriptorType	Descriptor type.	0x03																
0x7E	LANGID (lsb)	Language supported (0x0409 = US English). CY7C68310 only supports one language code		0x09															
0x7F	LANGID (msb)			0x04															
USB Standard Configuration Descriptor (VBUSPWRD Deasserted)																			
0x80	bLength	Length of Configuration descriptor in bytes.	0x09																
0x81	bDescriptorType	Descriptor type.	0x02																
0x82	bTotalLength (LSB)	Number of bytes returned in this configuration. This includes the configuration descriptor plus all the interface and endpoint descriptors.	0x27																
0x83	bTotalLength (MSB)		0x00																
0x84	bNumInterfaces	Number of interfaces supported. The CY7C68310 only supports one interface.	0x01																
0x85	bConfigurationValue	The value to use as an argument to Set Configuration to select the configuration. This value must be set to 0x02.	0x02																
0x86	iConfiguration	Index to the configuration string. This entry must equal half of the address value where the string starts or 0x00 if the string does not exist.		0x00															
0x87	bmAttributes	Device attributes for this configuration. Configuration characteristics: <table border="0" style="margin-left: 20px;"> <tr> <td>Bit</td> <td>Description</td> <td>On board default</td> </tr> <tr> <td>7</td> <td>Reserved. Set to '1'</td> <td>'1'</td> </tr> <tr> <td>6</td> <td>Self powered.</td> <td>'1' = Self-powered device</td> </tr> <tr> <td>5</td> <td>Remote wake-up.</td> <td>'0'</td> </tr> <tr> <td>4:0</td> <td>Reserved. Set to '0'</td> <td>'0'</td> </tr> </table>	Bit	Description	On board default	7	Reserved. Set to '1'	'1'	6	Self powered.	'1' = Self-powered device	5	Remote wake-up.	'0'	4:0	Reserved. Set to '0'	'0'	0xC0 or 0xE0	
Bit	Description	On board default																	
7	Reserved. Set to '1'	'1'																	
6	Self powered.	'1' = Self-powered device																	
5	Remote wake-up.	'0'																	
4:0	Reserved. Set to '0'	'0'																	
0x88	bMaxPower	Maximum power consumption for this configuration. Units used are mA*2 (i.e., 0x31 = 98 mA, 0xF9 = 498 mA).		0x31															

Table 6-2. EEPROM Organization (continued)

I ² C Address	Field Name	Field Description	Required I ² C Data	Example I ² C Data															
USB Other Speed Configuration Descriptor (VBUSPWRD Deasserted)																			
0x89	bLength	Length of Configuration descriptor in bytes.	0x09																
0x8A	bDescriptorType	Descriptor type.	0x07																
0x8B	bTotalLength (LSB)	Number of bytes returned in this configuration. This includes the configuration descriptor plus all the interface and endpoint descriptors.	0x27																
0x8C	bTotalLength (MSB)		0x00																
0x8D	bNumInterfaces	Number of interfaces supported. The CY7C68310 only supports one interface.	0x01																
0x8E	bConfigurationValue	The value to use as an argument to Set Configuration to select the configuration. This value must be set to 0x02.	0x02																
0x8F	iConfiguration	Index to the configuration string. This entry must equal half of the address value where the string starts or 0x00 if the string does not exist.		0x00															
0x90	bmAttributes	Device attributes for this configuration. Configuration characteristics: <table border="0" style="margin-left: 20px;"> <tr> <td>Bit</td> <td>Description</td> <td>On board default</td> </tr> <tr> <td>7</td> <td>Reserved. Set to '1'</td> <td>'1'</td> </tr> <tr> <td>6</td> <td>Self powered</td> <td>'1' = Self-powered device</td> </tr> <tr> <td>5</td> <td>Remote wake-up</td> <td>'0'</td> </tr> <tr> <td>4:0</td> <td>Reserved. Set to '0'</td> <td>'0'</td> </tr> </table>	Bit	Description	On board default	7	Reserved. Set to '1'	'1'	6	Self powered	'1' = Self-powered device	5	Remote wake-up	'0'	4:0	Reserved. Set to '0'	'0'	0xC0 or 0xE0	
Bit	Description	On board default																	
7	Reserved. Set to '1'	'1'																	
6	Self powered	'1' = Self-powered device																	
5	Remote wake-up	'0'																	
4:0	Reserved. Set to '0'	'0'																	
0x91	bMaxPower	Maximum power consumption for this configuration. Units used are mA*2 (i.e. 0x31 = 98 mA, 0xF9 = 498 mA).		0x31															
USB String Descriptor – Manufacturer																			
0x92	bLength	String descriptor length in bytes.		0x2C															
0x93	bDescriptorType	Descriptor type.	0x03																
0x94	bString	Unicode character LSB.		0x43 ("C")															
0x95	bString	Unicode character MSB.		0x00															
0x96	bString	Unicode character LSB.		0x79 ("y")															
0x97	bString	Unicode character MSB.		0x00															
0x98	bString	Unicode character LSB.		0x70 ("p")															
0x99	bString	Unicode character MSB.		0x00															
0x9A	bString	Unicode character LSB.		0x72 ("r")															
0x9B	bString	Unicode character MSB.		0x00															
0x9C	bString	Unicode character LSB.		0x65 ("e")															
0x9D	bString	Unicode character MSB.		0x00															
0x9E	bString	Unicode character LSB.		0x73 ("s")															
0x9F	bString	Unicode character MSB.		0x00															
0xA0	bString	Unicode character LSB.		0x73 ("s")															
0xA1	bString	Unicode character MSB.		0x00															
0xA2	bString	Unicode character LSB.		0x20 (" ")															
0xA3	bString	Unicode character MSB.		0x00															
0xA4	bString	Unicode character LSB.		0x53 ("S")															
0xA5	bString	Unicode character MSB.		0x00															
0xA6	bString	Unicode character LSB.		0x65 ("e")															
0xA7	bString	Unicode character MSB.		0x00															

Table 6-2. EEPROM Organization (continued)

I²C Address	Field Name	Field Description	Required I²C Data	Example I²C Data
0xA8	bString	Unicode character LSB.		0x6D ("m")
0xA9	bString	Unicode character MSB.		0x00
0xAA	bString	Unicode character LSB.		0x69 ("i")
0xAB	bString	Unicode character MSB.		0x00
0xAC	bString	Unicode character LSB.		0x63 ("c")
0xAD	bString	Unicode character MSB.		0x00
0xAE	bString	Unicode character LSB.		0x6F ("o")
0xAF	bString	Unicode character MSB.		0x00
0xB0	bString	Unicode character LSB.		0x6E ("n")
0xB1	bString	Unicode character MSB.		0x00
0xB2	bString	Unicode character LSB.		0x64 ("d")
0x1B	bString	Unicode character MSB.		0x00
0xB4	bString	Unicode character LSB.		0x75 ("u")
0xB5	bString	Unicode character MSB.		0x00
0xB6	bString	Unicode character LSB.		0x63 ("c")
0xB7	bString	Unicode character MSB.		0x00
0xB8	bString	Unicode character LSB.		0x74 ("t")
0x1B	bString	Unicode character MSB.		0x00
0xBA	bString	Unicode character LSB.		0x6F ("o")
0xBB	bString	Unicode character MSB.		0x00
0xBC	bString	Unicode character LSB.		0x72 ("r")
0xBD	bString	Unicode character MSB.		0x00
USB String Descriptor – Product				
0xBE	bLength	String descriptor length in bytes.		0x2A
0xBF	bDescriptorType	Descriptor Type.		0x03
0xC0	bString	Unicode character LSB.		0x55 ("U")
0xC1	bString	Unicode character MSB.		0x00
0x1C	bString	Unicode character LSB.		0x53 ("S")
0xC3	bString	Unicode character MSB.		0x00
0xC4	bString	Unicode character LSB.		0x52 ("B")
0xC5	bString	Unicode character MSB.		0x00
0xC6	bString	Unicode character LSB.		0x20 (" ")
0xC7	bString	Unicode character MSB.		0x00
0xC8	bString	Unicode character LSB.		0x53 ("S")
0xC9	bString	Unicode character MSB.		0x00
0xCA	bString	Unicode character LSB.		0x74 ("t")
0xCB	bString	Unicode character MSB.		0x00
0xCC	bString	Unicode character LSB.		0x6F ("o")
0xCD	bString	Unicode character MSB.		0x00
0xCE	bString	Unicode character LSB.		0x72 ("r")
0xCF	bString	Unicode character MSB.		0x00
0xD0	bString	Unicode character LSB.		0x61 ("a")
0xD1	bString	Unicode character MSB.		0x00

Table 6-2. EEPROM Organization (continued)

I ² C Address	Field Name	Field Description	Required I ² C Data	Example I ² C Data
0xD2	bString	Unicode character LSB.		0x67 (“g”)
0xD3	bString	Unicode character MSB.		0x00
0xD4	bString	Unicode character LSB.		0x65 (“e”)
0xD5	bString	Unicode character MSB.		0x00
0xD6	bString	Unicode character LSB.		0x20 (“ ”)
0xD7	bString	Unicode character MSB.		0x00
0xD8	bString	Unicode character LSB.		0x41 (“A”)
0xD9	bString	Unicode character MSB.		0x00
0xDA	bString	Unicode character LSB.		0x64 (“d”)
0xDB	bString	Unicode character MSB.		0x00
0xDC	bString	Unicode character LSB.		0x61 (“a”)
0xDD	bString	Unicode character MSB.		0x00
0xDE	bString	Unicode character LSB.		0x70 (“p”)
0xDF	bString	Unicode character MSB.		0x00
0xE0	bString	Unicode character LSB.		0x74 (“t”)
0xE1	bString	Unicode character MSB.		0x00
0xE2	bString	Unicode character LSB.		0x65 (“e”)
0xE3	bString	Unicode character MSB.		0x00
0xE4	bString	Unicode character LSB.		0x72 (“r”)
0xE5	bString	Unicode character MSB.		0x00
USB String Descriptor – Serial Number				
0xE6	bLength	String descriptor length in bytes.		0x1A
0xE7	bDescriptorType	Descriptor type.		0x03
0xE8	bString	Unicode character LSB.		0xXX
0xE9	bString	Unicode character MSB.		0x00
0xEA	bString	Unicode character LSB.		0xXX
0xEB	bString	Unicode character MSB.		0x00
0xEC	bString	Unicode character LSB.		0xXX
0xED	bString	Unicode character MSB.		0x00
0xEE	bString	Unicode character LSB.		0xXX
0xEF	bString	Unicode character MSB.		0x00
0xF0	bString	Unicode character LSB.		0xXX
0xF1	bString	Unicode character MSB.		0x00
0xF2	bString	Unicode character LSB.		0xXX
0xF3	bString	Unicode character MSB.		0x00
0xF4	bString	Unicode character LSB.		0xXX
0xF5	bString	Unicode character MSB.		0x00
0xF6	bString	Unicode character LSB.		0xXX
0xF7	bString	Unicode character MSB.		0x00
0xF8	bString	Unicode character LSB.		0xXX
0xF9	bString	Unicode character MSB.		0x00
0xFA	bString	Unicode character LSB.		0xXX
0xFB	bString	Unicode character MSB.		0x00

Table 6-2. EEPROM Organization (continued)

I ² C Address	Field Name	Field Description	Required I ² C Data	Example I ² C Data
0xFC	bString	Unicode character LSB.		0xXX
0xFD	bString	Unicode character MSB.		0x00
0xFE	bString	Unicode character LSB.		0xXX
0xFF	bString	Unicode character MSB.		0x00

6.3 Programming the EEPROM

Programming of the I²C memory device can be accomplished using an external device programmer, CY7C68310 supported vendor-specific USB commands, or an in-system programmer such as a bed of nails. *Table 6-3* shows the format of the vendor-specific commands used to program the EEPROM via

USB. Any vendor-specific USB write request to the Serial ROM device configuration space will simultaneously update internal configuration register values as well. If the I²C device is programmed without vendor specific USB commands, CY7C68310 must be synchronously reset (nRESET) before configuration data is reloaded.

Table 6-3. EEPROM-related Vendor-specific Commands

Label	bmRequestType	bRequest	wValue	wIndex	wLength	Data
LOAD_CONFIG_DATA	0x40	0x01	Data Destination	Starting Address	Data Length	Configuration Data
READ_CONFIG_DATA	0xC0	0x02	Data Source	Starting Address	Data Length	Configuration Data

The CY7C68310 supports a subset of the “slow mode” specification (100 KHz) required for 24LCXXB EEPROM family device support. Features such as “Multi-Master,” “Clock Synchronization” (the SCL pin is output only), “10-bit addressing,” and “CBUS device support” are not supported. Vendor-specific USB commands allow the CY7C68310 to address up to 2 Kbytes of data (although configuration/descriptor information is limited to 512 bytes of register space).

value must be evenly divisible by eight. Writes to I²C-compatible memory devices must not cross 256-byte page boundaries, i.e., start and finish write addresses must have equal modulo 256 values. Write operations with beginning and end addresses that do not fall in the same 256-byte page will result in a STALL condition. Illegal values for wValue as well as attempts to write to an I²C-compatible memory device when none is connected will result in a STALL condition.

6.3.1 LOAD_CONFIG_DATA

This request enables configuration data writes to the data source specified by the wValue field. The wIndex field specifies the starting address and the wLength field denotes the data length in bytes.

Legal values for wValue are as follows:

- 0x0000 Configuration bytes, address range 0x2 – 0xF
- 0x0002 External I²C memory device.

Configuration byte writes must be constrained to addresses 0x2 through 0xF, as shown in *Table 6-2*. Attempts to write outside this address space will result in a STALL condition. Configuration byte writes only overwrite CY7C68310 Configuration Byte registers, the original data source remains unchanged (I²C-compatible memory device, FBh identify data, or internal ROM).

Single byte writes to the I²C-compatible memory devices can start at any address. Writes greater than a single byte must only start on eight-byte boundaries, meaning that the address

6.3.2 READ_CONFIG_DATA

This USB request allows data retrieval from the data source specified by the wValue field. Data is retrieved beginning at the address specified by the wIndex field. The wLength field denotes the length in bytes of data requested from the data source.

Legal values for wValue are as follows:

- 0x0000 Configuration bytes, addresses 0x0 – 0xF only
- 0x0001 Internal ROM
- 0x0002 External I²C-compatible memory device
- 0x0003 Vendor-specific identify (FBh) data

Illegal values for wValue will result in a STALL condition on the USB port. Attempted reads from an I²C-compatible memory device when none is connected or attempted reads from FBh data when not in IMODE will result in a STALL condition. Attempts to read configuration bytes with starting addresses greater than 0xF will also result in a STALL condition.

7.0 Timing Characteristics

7.1 I²C-compatible Memory Device Interface Timing

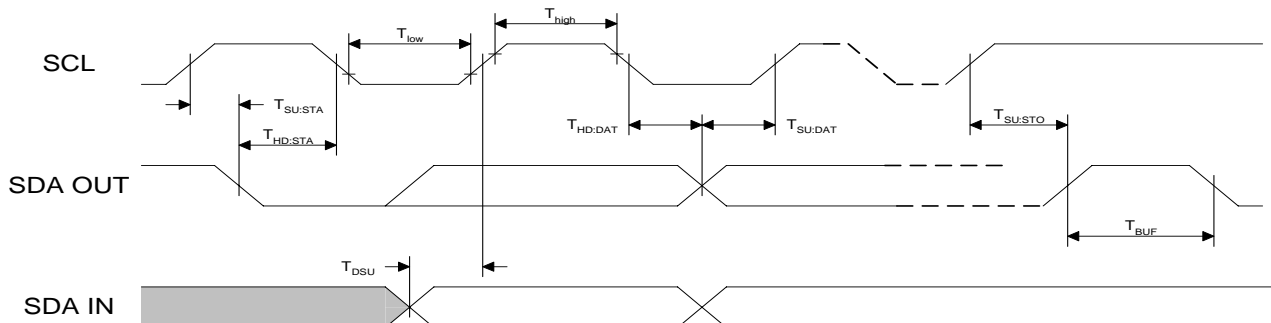

I ² C-compatible Device Parameter	Symbol	Value
Clock high time	T_{high}	5066 ns
Clock low time	T_{low}	5066 ns
Start condition hold time	$T_{HD:STA}$	5066 ns
Start condition set-up time	$T_{SU:STA}$	5066 ns
Data output hold time	$T_{HD:DAT}$	5066 ns
Data output set-up time	$T_{SU:DAT}$	5066 ns
Stop condition set-up time	$T_{SU:STO}$	5066 ns
Required data valid before clock	T_{DSU}	500 ns
Min time bus must be free before next transmission	T_{BUF}	5066 ns

Figure 7-1. I²C Interface Timing

7.2 USB Interface Timing

The CY7C68310 transceiver complies to the timing characteristics as stated in the USB Specification version 2.0. The CY7C68310 can operate at either the high-speed or full-speed signalling rate.

7.3 ATA/ATAPI Interface Timing

The ATA interface supports ATA PIO modes 0 to 4, and Ultra DMA modes 0 to 4, per the ATA Attachment – 6 with Packet Interface revision 3b. All input signals on the ATA/ATAPI port are considered asynchronous and are synchronized to the chip's internal system clock. All output signals are clocked using the chip's internal system clock, for which there is no external reference. Thus, the output signals should also be considered asynchronous. The PIO mode used for data register accesses is retrieved from the device or specified in the CY7C68310 configuration bytes.

7.4 External Clock Source Timing

The CY7C68310 derives its internal system clock from an external clock source. The external clock input signal

frequency is measured at one half of the 2.5V power source (VDD25). The CY7C68310 internal PLL can be clocked using either a 30-MHz ($\pm 0.005\%$) fundamental-mode crystal or a 2.5V, 50% duty-cycle square wave. The recommended external clock source for the CY7C68310 is the PRE XH30PRF10BL crystal (10-pF load capacitance).

7.5 Reset Timing

The CY7C68310 requires an off-chip power-on reset circuit. nRESET must be held asserted for a minimum of 1 ms after power is stable to cause a chip reset.

8.0 External Circuitry Requirements

Certain external components are required for proper CY7C68310 operation. The following figure details the minimum required circuitry for normal operation. Additional components may be required to support configurable CY7C68310 features, if utilized.

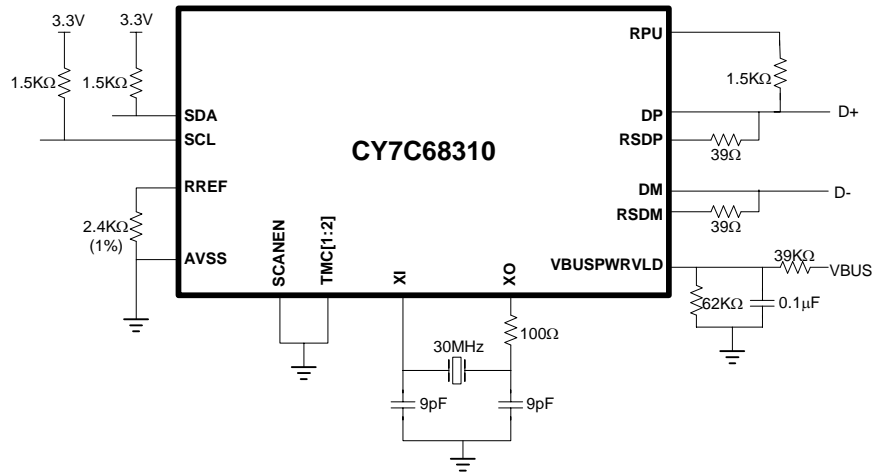

Figure 8-1. External Circuitry Requirements

8.1 ATA Interface Termination

Design practices as outlined in the ATA/ATAPI-6 specification for signal integrity should be followed with systems that utilize a ribbon cable interconnect between the CY7C68310's ATA interface and the attached ATA/ATAPI device, especially if Ultra DMA Mode is utilized.

8.2 Power Supply Regulation

At no time should the 3.3V power rail drop below the 2.5V rail for proper device operation. Care should be taken to ensure that the power rails rise and fall without allowing the 3.3V supply to drop below the 2.5V supply. The recommended method is to cascade voltage regulating circuits such that the 2.5V supply is powered from the 3.3V supply.

8.3 Pull-ups/Pull-downs on High-Z Pins

Certain output pins act as open-drain and remain at a high-Z state unless asserting a '0.' These pins include SCL, SDA, LOWPWR, and nPWR500. If their functionality is utilized, these pins must be tied to pull-up resistors to avoid floating while in a high-Z state. These pins can be left as no-connects if the functionality is not utilized.

Table 9-1. LOAD_MFG_DATA Command Format

Label	bmRequestType	bRequest	wValue	wIndex	wLength	Data
LOAD_MFG_DATA	0x40	0x05	Disable/Enable	Starting Address	Data Length	Mfg. Test Data

Legal values for wValue are as follows:

- 0x0000 Normal operation mode – returns CY7C68310 to normal operation regardless of previous command data sets (power-on reset default).
- 0x0001 Manufacturing Test Mode – manufacturing test registers control specific CY7C68310 outputs cells to enable board level testing in the manufacturing environment.

9.0 Manufacturing Interconnect Test Support

Manufacturing Test Mode is provided as a means to implement board- and system-level interconnect tests. During Manufacturing Test Mode operation, all outputs not associated directly with USB operation are controllable. Normal state machine and register control of output pins are disabled. Two vendor-specific USB requests (LOAD_MFG_DATA and READ_MFG_DATA) are used in Manufacturing Test Mode operation.

9.1 LOAD_MFG_DATA

This USB request is used to enable and control Manufacturing Test Mode operation. While in Manufacturing Test Mode, individual pins may be asserted or deasserted depending upon the contents of the data field. The DD and GPIO pins may also be set to a high-Z state in preparation for READ_MFG_DATA command operations. Control of the select CY7C68310 I/O pins and their high-Z controls are mapped to the USB data packet associated with this request.

Legal values for wLength are as follows:

- 0x0000 Valid only when wValue = 0x0000; used when disabling Manufacturing Test Mode of operation
- 0x0007 Valid only when wValue = 0x0001. For proper Manufacturing Test Mode operation, wLength must equal 0x0007. Any data packet lengths greater than 7 will result in a STALL condition.

Table 9-2. Bit-wise Mapping of LOAD_MFG_DATA Test Data

Byte	Bit(s)	Test/High-Z Control Register Name
0	0	LOWPWR
0	1	Reserved – Value will not affect output
0	2	nPWR500
0	3	nATARST
0	4	nDIOW
0	5	nDIOR
0	6	nDMACK
0	7	ATAPUEN
1	0	Reserved – Value will not affect output
1	2:1	nCS[1:0]
1	5:3	DA[2:0]
1	6	SCL
1	7	DD_EN – ‘1’ = Enable output (set for writes), ‘0’ = high-Z DD[15:0] (set for reads)
2	7:0	DD[7:0]
3	7:0	DD[15:8]
4	2:0	GPIO[2:0]
4	3	Reserved – Value will not affect output
4	6:4	GPIO_EN[2:0] – ‘1’ = Enable output (set for writes), ‘1’ = high-Z GPIO[2:0] (set for reads)
4	7	Reserved – Value will not affect output
5	7:0	Reserved – Value will not affect output

9.2 READ_MFG_DATA

This USB request returns a “snapshot in time” of selected input pins. The input pin states are bit-wise mapped to the USB data packed associated with this request. CY7C68310 input pins

not associated directly with USB operation can be sampled at any time during normal or Manufacturing Test Mode operation. This request is independent of normal CY7C68310 state machine control or Manufacturing Test Mode write operations.

Table 9-3. READ_MFG_DATA Command Format

Label	bmRequestType	bRequest	wValue	wIndex	wLength	Data
READ_MFG_DATA	0xC0	0x06	0x00	0x00	Data Length	Mfg. Test Data

Legal values for wValue are as follows:

- 0x0000 wValue must be set to 0x0000.

Legal values for wLength are as follows:

- 0x0001–0x0008 Any wLength value greater than 0x0008 will result in a STALL response.

Table 9-4. Bit-wise Mapping of READ_MFG_Data Test Data

Byte	Bit(s)	Pin Name
0	0	DRV_PWRVLD
0	1	VBUS_PWRVLD
0	2	VBUS_PWRD
0	3	DISKRDY
0	4	SYSIRQ
0	5	IORDY
0	6	DMARQ
0	7	nEJECT
1	0	ATAIRQ
1	1	Will always return '1'
1	2	LOWPWR
1	3	Reserved – Disregard value
1	4	nPWR500
1	5	nATARST
1	6	nDIOW
1	7	nDIOR
2	0	nDMACK
2	1	ATAPUEN
2	2	Reserved – Disregard value
2	4:3	nCS[1:0]
2	7:5	DA[2:0]
3	7:0	DD[7:0]
4	7:0	DD[15:8]
5	2:0	GPIO[2:0]
5	3	Will always return '0'
5	4	DD_EN
5	7:5	GPIO_EN[2:0]
6	0	MFG_SEL (manufacturing test mode enable)
6	1	ATAEN
6	2:7	Will always return '1'
7	7:0	Will always return '1'

10.0 Absolute Maximum Ratings

Storage Temperature	-65 to 150°C
Ambient Temperature with power supplied	0 to 70°C
Supply Voltage to Ground Potential	-0.5 to 5.5 V
DC Input Voltage to Any Input Pin	-0.5 to 5.5 V
DC Voltage Applied to Outputs in high-Z	-0.5 to 5.5 V
Power Dissipation	235 mW
Static Discharge Voltage (Meets NEC ASIC ESD specifications IEC-GQ-6002-01 and IEC-6005-01)	> 2000 V
Max Output Current per I/O port	20 mA
Latch-up Current	> 200 mA

11.0 Operating Conditions

Operating temperature..... 0 to 70°C

12.0 DC Characteristics

Parameter	Description		Min.	Typ.	Max.	Unit	
V _{DD}	Digital voltage supply		2.25	2.50	2.75	V	
V _{DDA}	Analog voltage supply		2.25	2.50	2.75	V	
V _{DDIO}	I/O cell voltage supply		3.0	3.3	3.6	V	
V _{IH}	Input high voltage		2.0		V _{DDIO} + 0.5	V	
V _{IL}	Input low voltage		-0.5		0.8	V	
V _{OH}	Output high voltage at I _{OH}		2.4			V	
V _{OL}	Output low voltage at I _{OL}				0.4	V	
I _{OH}	Source current at V _{OH}		6			mA	
I _{OL}	Sink current at V _{OL}		6			mA	
I _{nCFG}	Unconfigured current	Full-speed		40		mA	
		High-speed		60		mA	
I _{CC}	Configured idle	Full-speed	2.5V Supply		36	mA	
			3.3V Supply		2	mA	
		High-speed	2.5V Supply		55	mA	
			3.3V supply		2	mA	
	Configured operational	Full-speed	2.5V Supply		53	mA	
			3.3V Supply		11	mA	
		High-speed	Compact Flash	2.5V Supply		65	mA
				3.3V Supply		6	mA
			2.5" HDD (See Note)	2.5V Supply		73	mA
				3.3V Supply		9	mA
3.5" HDD (See Note)	2.5V Supply		74	mA			
	3.3V Supply		19	mA			
I _{SUP}	Current in USB suspend (inactive, connected)			250		μA	
I _{SLP}	Current in Sleep mode (inactive, unconnected)		0.7		10	μA	

Note: All values in this table assume 25°C ambient temperature and nominal voltage unless otherwise stated. All "Configured operational" measurements assume a 50/50 read/write duty cycle.

13.0 Ordering Information

Part Number	[Package Type]
CY7C68310-80AC	80-Lead TQFP
CY7C68310-80AXC ^[1]	80-Lead TQFP Lead-Free Package
CY4617	CY7C68310 Mass Storage Reference Design Kit

Note:

- The Lead-Free option should be used for new designs. It is recommended that existing designs migrate to Lead-Free parts.

16.0 Disclaimers, Trademarks, and Copyrights

Purchase of I²C components from Cypress, or one of its sublicensed Associated Companies, conveys a license under the Philips I²C Patent Rights to use these components in an I²C system, provided that the system conforms to the I²C Standard Specification as defined by Philips. ISD-300LP is a trademark of Cypress Semiconductor. All product and company names mentioned in this document are the trademarks of their respective holders.

Document History Page

Description Title: CY7C68310 ISD-300LP™ Low-Power USB 2.0 to ATA/ATAPI Bridge IC				
Document Number: 38-08030				
REV.	ECN No.	Issue Date	Orig. of Change	Description of Change
**	118297	09/18/02	BHA	New Data Sheet
*A	120307	12/12/02	GIR	Revised for Preliminary status
*B	123509	04/04/03	GIR	Revised to include first silicon information
*C	126049	04/07/03	CVR	Post to external website CY7C68310-80AC
*D	126323	05/21/03	GIR	Updated Suspend Current and included Sleep Mode in Section 12.0 Added ESD Testing Methodology and Power Dissipation values to Section 10.0 Revised for Final status
*E	127185	06/05/03	BEH	Changed Static Discharge voltage to > 2000V(1) Replaced previous Status Discharge footnotes with the following: "1. Meets NEC ASIC ESD specifications IEC-GQ-6002-01 and IEC-6005-01" Changed DC Specification $I_{SLP} < 10 \mu A$ typical to 10 μA max
*F	127739	09/03/03	GIR	Corrected formatting of all tables Added sections on ATACB and ATACB2 Corrected pin descriptions in Sections 4.3.4, 4.3.6, 4.3.8, 4.3.15, 4.3.16, and 4.3.17 Corrected values/contents of some EEPROM table fields to clarify IROS contents Divided 2.5V and 3.3V current consumption in Section 10 Swapped order of PCB Layout Guidelines and Package Diagram sections Corrected spelling and grammar Added USB certification logo to cover page Added USB-IF test ID number to Section 1.1 list
*G	131946	02/06/04	KKU	Updated to include lead-free part numbers. Section 1.1 changed "Compact 80-Lead TQFP" to "Compact 80-pin TQFP package with a Lead-Free option" Section 11.0 added: CY7C68310-80AZC 80-Lead TQFP Lead-Free Package with footnote that new designs should use Lead-Free part and existing designs should migrate to Lead-Free parts.
*H	234589	SEE ECN	KKU	Reformatted Data sheet to new standard. Changed section 12.0 for lead free marketing part number in accordance to spec change in 28-00054.

Copyright © Each Manufacturing Company.

All Datasheets cannot be modified without permission.

This datasheet has been download from :

www.AllDataSheet.com

100% Free DataSheet Search Site.

Free Download.

No Register.

Fast Search System.

www.AllDataSheet.com