

## Low On-Resistance Wideband/Video Switches

### DESCRIPTION

The DG641, DG642, DG643 are high performance monolithic video switches designed for switching wide bandwidth analog and digital signals. DG641 is a quad SPST, DG642 is a single SPDT, and DG643 is a dual SPDT function. These devices have exceptionally low on-resistances ( $5\ \Omega$  typ-DG642), low capacitance and high current handling capability.

To achieve TTL compatibility, low channel capacitances and fast switching times, the DG641, DG642, DG643 are built on the Vishay Siliconix proprietary D/CMOS process. Each switch conducts equally well in both directions when on, and blocks up to  $14\ V_{p-p}$  when off. An epitaxial layer prevents latchup.

### FEATURES

- Wide bandwidth: 500 MHz
- Low crosstalk at 5 MHz: - 85 dB
- Low  $R_{DS(on)}$ :  $5\ \Omega$ , DG642
- TTL logic compatible
- Fast switching:  $t_{ON}$  50 ns
- Single supply compatibility
- High current: 100 mA, DG642

### BENEFITS

- High precision
- Improved frequency response
- Low insertion loss
- Improved system performance
- Reduced board space
- Low power consumption

### APPLICATIONS

- RF and video switching
- RGB switching
- Video routing
- Cellular communications
- ATE
- Radar/FLIR systems
- Satellite receivers
- Programmable filters

### FUNCTIONAL BLOCK DIAGRAM AND PIN CONFIGURATION

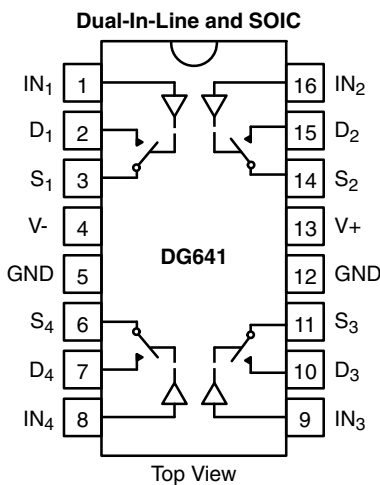

TRUTH TABLE (DG641)	
Logic	Switch
0	OFF
1	ON

Logic "0"  $\leq 0.8\ V$   
 Logic "1"  $\geq 2.4\ V$

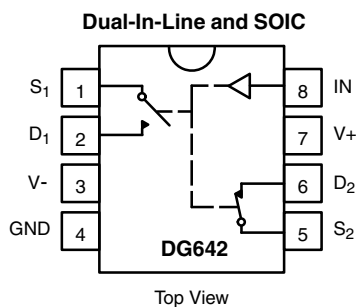

TRUTH TABLE (DG642)		
Logic	SW <sub>1</sub>	SW <sub>2</sub>
0	OFF	ON
1	ON	OFF

Logic "0"  $\leq 0.8\ V$   
 Logic "1"  $\geq 2.4\ V$

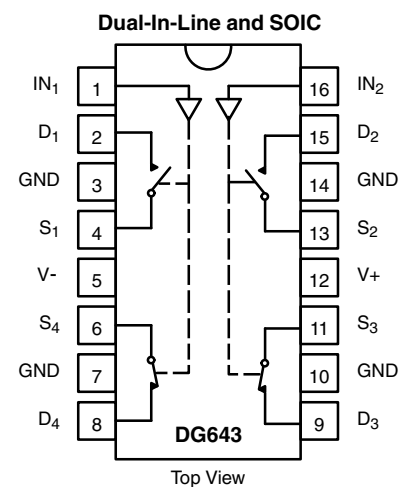

TRUTH TABLE (DG643)		
Logic	SW <sub>1</sub> , SW <sub>2</sub>	SW <sub>3</sub> , SW <sub>4</sub>
0	OFF	ON
1	ON	OFF

Logic "0"  $\leq 0.8\ V$   
 Logic "1"  $\geq 2.4\ V$

ORDERING INFORMATION		
Temp. Range	Package	Part Number
<b>DG641</b>		
- 40 °C to 85 °C	16-Pin Plastic DIP	DG641DJ
	16-Pin Narrow SOIC	DG641DY
<b>DG642</b>		
- 40 °C to 85 °C	8-Pin Plastic DIP	DG642DJ
	8-Pin Narrow SOIC	DG642DY
<b>DG643</b>		
- 40 °C to 85 °C	16-Pin Plastic DIP	DG643DJ
	16-Pin Narrow SOIC	DG643DY

ABSOLUTE MAXIMUM RATINGS (T <sub>A</sub> = 25 °C, unless otherwise noted)			
Parameter	Symbol	Limit	Unit
V+ to V-		- 0.3 to 21	V
V+ to GND		- 0.3 to 21	
V- to GND		- 19 to + 0.3	
Digital Inputs		(V-) - 0.3 V to (V+) + 0.3 V or 20 mA, whichever occurs first	
V <sub>S</sub> , V <sub>D</sub>		(V-) - 0.3 V to (V+) + 14 V or 20 mA, whichever occurs first	mA
Continuous Current (Any terminal except S or D)		20	
Continuous Current S or D	DG641, DG643	75	
	DG642	100	
Current, S or D (Pulsed at 1 ms, 10 % duty cycle max)	DG641, DG643	200	
	DG642	300	
Storage Temperature		- 65 to 125	°C
Power Dissipation (Package) <sup>b</sup>	8-Pin Plastic DIP and Narrow SOIC <sup>c</sup>	300	mW
	16-Pin Plastic DIP <sup>d</sup>	470	
	16-Pin Narrow SOIC <sup>e</sup>	600	

Notes:

- a. Signals on S<sub>x</sub>, D<sub>x</sub>, or IN<sub>x</sub> exceeding V+ or V- will be clamped by internal diodes. Limit forward diode current to maximum current ratings.
- b. All leads welded or soldered to PC board.
- c. Derate 7.6 mW/°C above 75 °C.
- d. Derate 6 mW/°C above 75 °C.
- e. Derate 80 mW/°C above 75 °C.

**SCHEMATIC DIAGRAM** (Typical Channel)

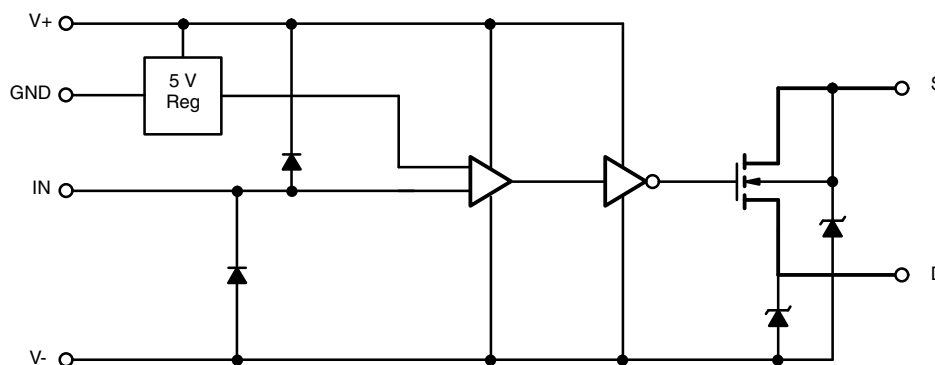

Figure 1.



SPECIFICATIONS (for DG641 and DG643)							
Parameter	Symbol	Test Conditions Unless Otherwise Specified V <sub>+</sub> = 15 V, V <sub>-</sub> = -3 V V <sub>INH</sub> = 2.4 V, V <sub>INL</sub> = 0.8 V <sup>e</sup>	Temp. <sup>a</sup>	Limits - 40 °C to 85 °C			Unit
				Min. <sup>b</sup>	Typ. <sup>c</sup>	Max. <sup>b</sup>	
<b>Analog Switch</b>							
Analog Signal Range <sup>d</sup>	V <sub>ANALOG</sub>	V <sub>-</sub> = -5 V, V <sub>+</sub> = 12 V	Full	-5		8	V
		V <sub>-</sub> = GND V, V <sub>+</sub> = 12 V	Full	0		8	
Drain-Source On-Resistance	R <sub>DS(on)</sub>	I <sub>S</sub> = -10 mA, V <sub>D</sub> = 0 V	Room		8	15	Ω
R <sub>DS(on)</sub> Match	ΔR <sub>DS(on)</sub>		Room		1	2	
Source Off Leakage Current	I <sub>S(off)</sub>	V <sub>S</sub> = 0 V, V <sub>D</sub> = 10 V	Room	-10	-0.02	10	nA
Drain Off Leakage Current	I <sub>D(off)</sub>	V <sub>S</sub> = 10 V, V <sub>D</sub> = 0 V	Full	-100	-0.02	100	
Channel On Leakage Current	I <sub>D(on)</sub>	V <sub>S</sub> = V <sub>D</sub> = 0 V	Full	-100	-0.1	100	
<b>Digital Control</b>							
Input Voltage High	V <sub>INH</sub>		Full	2.4			V
Input Voltage Low	V <sub>INL</sub>		Full			0.8	
Input Current	I <sub>IN</sub>	V <sub>IN</sub> = GND or V <sub>+</sub>	Room	-1	0.05	1	μA
			Full	-20		20	
<b>Dynamic Characteristics</b>							
On State Input Capacitance <sup>d</sup>	C <sub>S(on)</sub>	V <sub>S</sub> = V <sub>D</sub> = 0 V	Room		10	20	pF
Off State Output Capacitance <sup>d</sup>	C <sub>S(off)</sub>	V <sub>S</sub> = 0 V	Room		4	12	
Off State Input Capacitance <sup>d</sup>	C <sub>D(off)</sub>	V <sub>D</sub> = 0 V	Room		4	12	
Bandwidth	BW	R <sub>L</sub> = 50 Ω, see figure 6	Room		500		MHz
Turn On Time	t <sub>ON</sub>	R <sub>L</sub> = 1 kΩ, C <sub>L</sub> = 35 pF see figure 2	Room		50	70	ns
Turn Off Time	t <sub>OFF</sub>		Full		28	50	
Charge Injection	Q	C <sub>L</sub> = 1000 pF, V <sub>D</sub> = 0 V see figure 3	Room		-19		pC
Off Isolation	OIRR	R <sub>IN</sub> = 75 Ω, R <sub>L</sub> = 75 Ω f = 5 MHz, see figure 4	Room		-60		dB
All Hostie Crosstalk	X <sub>TALK</sub>	R <sub>IN</sub> = 10 Ω, R <sub>L</sub> = 75 Ω f = 5 MHz, see figure 5	Room		-87		
<b>Power Supplies</b>							
Positive Supply Current	I <sub>+</sub>	V <sub>IN</sub> = 0 V or V <sub>IN</sub> = 5 V	Room		3.5	6	mA
Negative Supply Current	I <sub>-</sub>		Full		-6	-3	
			Full		-9		

Notes:

- a. Room = 25 °C, Full = as determined by the operating temperature suffix.
- b. Typical values are for DESIGN AID ONLY, not guaranteed nor subject to production testing.
- c. The algebraic convention whereby the most negative value is a minimum and the most positive a maximum, is used in this data sheet.
- d. Guaranteed by design, not subject to production test.
- e. V<sub>IN</sub> = input voltage to perform proper function.



SPECIFICATIONS (for DG642)							
Parameter	Symbol	Test Conditions Unless Otherwise Specified $V_+ = 15\text{ V}$ , $V_- = -3\text{ V}$ $V_{INH} = 2.4\text{ V}$ , $V_{INL} = 0.8\text{ V}^e$	Temp. <sup>a</sup>	Limits - 40 °C to 85 °C			Unit
				Min. <sup>b</sup>	Typ. <sup>c</sup>	Max. <sup>b</sup>	
<b>Analog Switch</b>							
Analog Signal Range <sup>d</sup>	$V_{ANALOG}$	$V_- = -5\text{ V}$ , $V_+ = 12\text{ V}$	Full	- 5		8	V
		$V_- = \text{GND V}$ , $V_+ = 12\text{ V}$	Full	0		8	
Drain-Source On-Resistance	$R_{DS(on)}$	$I_S = -10\text{ mA}$ , $V_D = 0\text{ V}$	Room		5	8	$\Omega$
$R_{DS(on)}$ Match	$\Delta R_{DS(on)}$		Room		0.5	1	
Source Off Leakage Current	$I_{S(off)}$	$V_S = 0\text{ V}$ , $V_D = 10\text{ V}$	Room	- 10	- 0.04	10	nA
Drain Off Leakage Current	$I_{D(off)}$	$V_S = 10\text{ V}$ , $V_D = 0\text{ V}$	Full	- 200		200	
Channel On Leakage Current	$I_{D(on)}$	$V_S = V_D = 0\text{ V}$	Full	- 200	- 0.2	10	
<b>Digital Control</b>							
Input Voltage High	$V_{INH}$		Full	2.4			V
Input Voltage Low	$V_{INL}$		Full			0.8	
Input Current	$I_{IN}$	$V_{IN} = \text{GND or } V_+$	Room	- 1	0.05	1	$\mu\text{A}$
			Full	- 20		20	
<b>Dynamic Characteristics</b>							
On State Input Capacitance <sup>d</sup>	$C_{S(on)}$	$V_S = V_D = 0\text{ V}$	Room		19	40	pF
Off State Input Capacitance <sup>d</sup>	$C_{S(off)}$	$V_D = 0\text{ V}$	Room		8	20	
Off State Output Capacitance <sup>d</sup>	$C_{D(off)}$	$V_S = 0\text{ V}$	Room		8	20	
Bandwidth	BW	$R_L = 50\ \Omega$ , see figure 6	Room		500		MHz
Turn On Time	$t_{ON}$	$R_L = 1\text{ k}\Omega$ , $C_L = 35\text{ pF}$ see figure 2	Room		60	100	ns
Turn Off Time	$t_{OFF}$		Full		40	60	
Charge Injection	Q	$C_L = 1000\text{ pF}$ , $V_D = 0\text{ V}$ see figure 3	Room		- 40		pC
Off Isolation		$R_{IN} = 75\ \Omega$ , $R_L = 75\ \Omega$ $f = 5\text{ MHz}$ , see figure 4	Room		- 63		dB
All Hostie Crosstalk	$X_{TALK(AH)}$	$R_{IN} = 10\ \Omega$ , $R_L = 75\ \Omega$ $f = 5\text{ MHz}$ , see figure 5	Room		- 85		
<b>Power Supplies</b>							
Positive Supply Current	I+	$V_{IN} = 0\text{ V or } V_{IN} = 5\text{ V}$	Room		3.5	6	mA
Negative Supply Current	I-		Full		- 6	- 3	
			Full		- 9		

Notes:

- a. Room = 25 °C, Full = as determined by the operating temperature suffix.
- b. The algebraic convention whereby the most negative value is a minimum and the most positive a maximum, is used in this data sheet.
- c. Typical values are for DESIGN AID ONLY, not guaranteed nor subject to production testing.
- d. Guaranteed by design, not subject to production test.
- e.  $V_{IN}$  = input voltage to perform proper function.

Stresses beyond those listed under "Absolute Maximum Ratings" may cause permanent damage to the device. These are stress ratings only, and functional operation of the device at these or any other conditions beyond those indicated in the operational sections of the specifications is not implied. Exposure to absolute maximum rating conditions for extended periods may affect device reliability.

**TYPICAL CHARACTERISTICS** ( $T_A = 25^\circ\text{C}$ , unless otherwise noted)

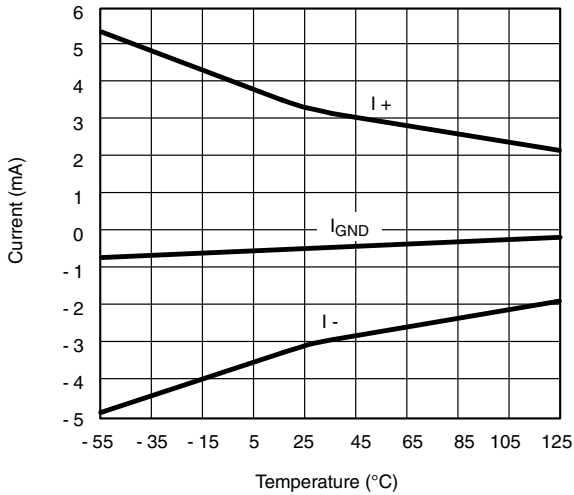

**Supply Current vs. Temperature**

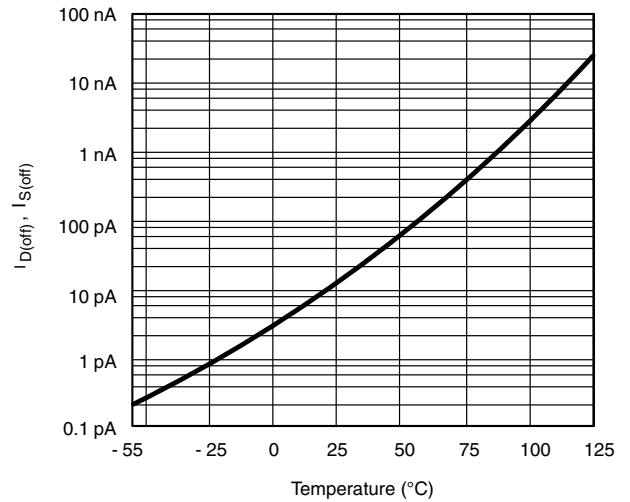

**Leakages vs. Temperature**

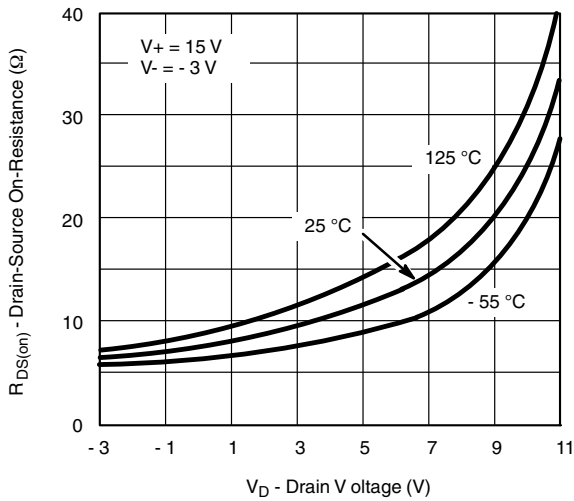

**$R_{DS(on)}$  vs. Drain Voltage**

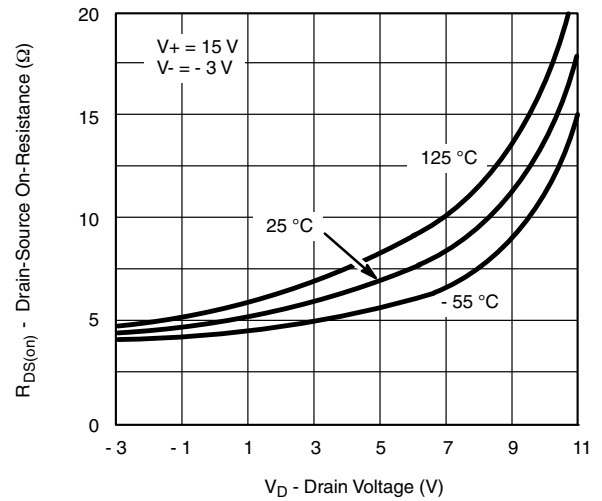

**$R_{DS(on)}$  vs. Drain Voltage**

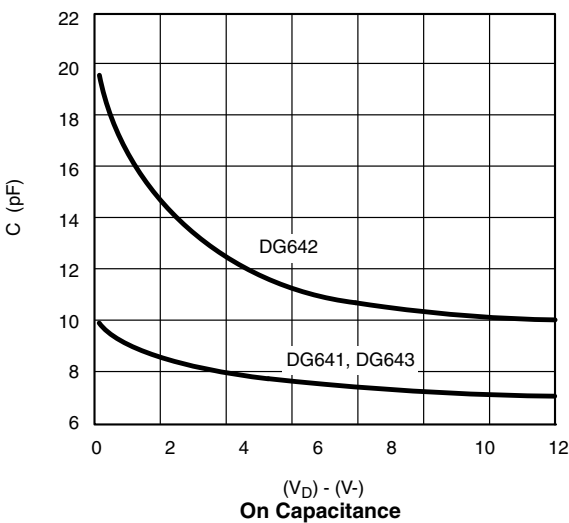

**On Capacitance**

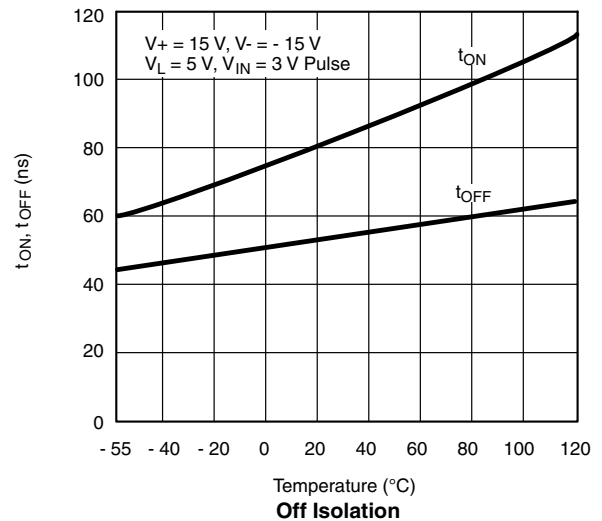

**Off Isolation**

## TYPICAL CHARACTERISTICS $(T_A = 25\text{ }^\circ\text{C, unless otherwise noted)}$

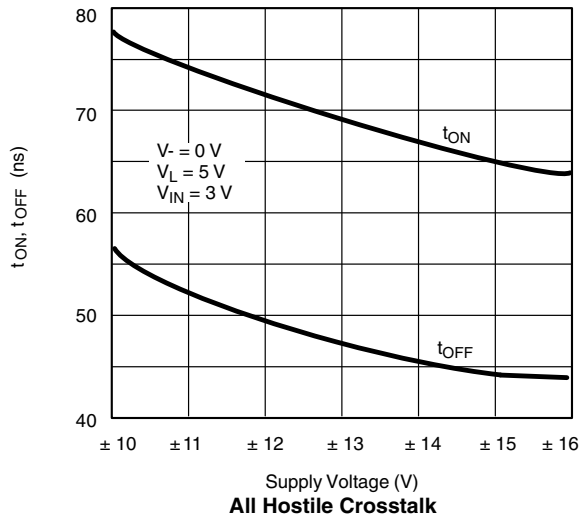

All Hostile Crosstalk

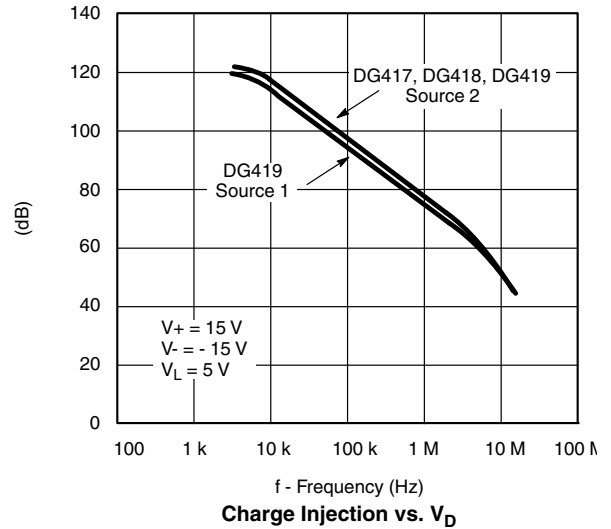

Charge Injection vs.  $V_D$

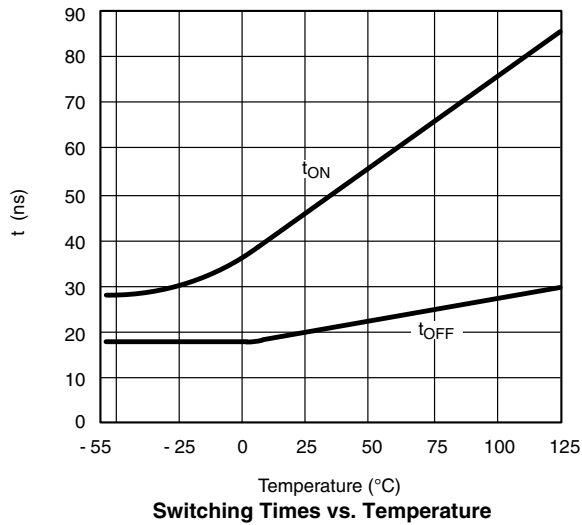

Switching Times vs. Temperature

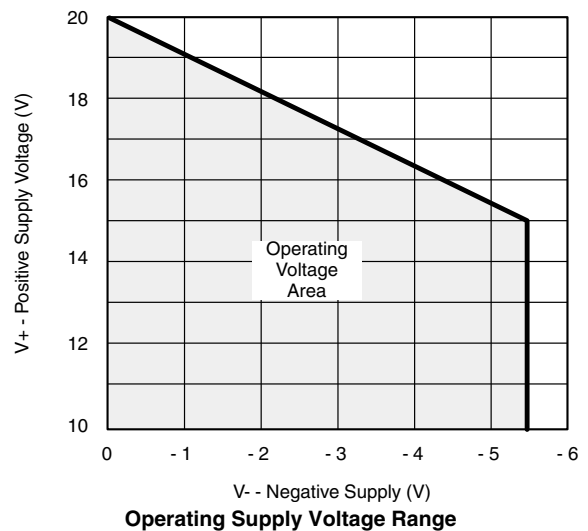

Operating Supply Voltage Range

## TEST CIRCUITS

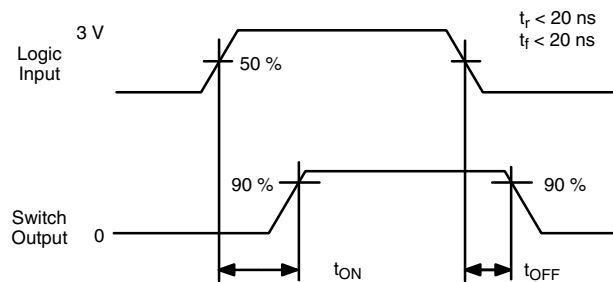
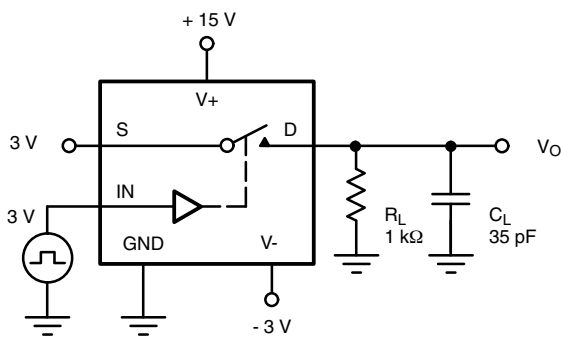
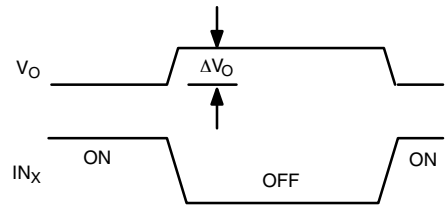
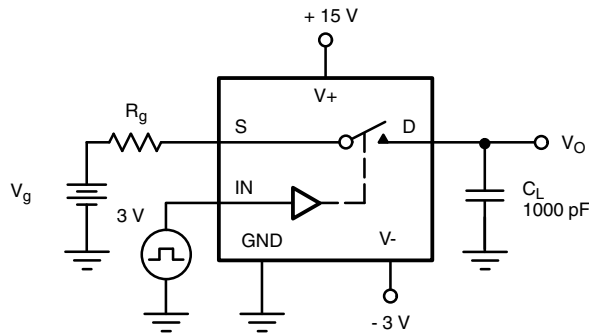

Figure 2. Switching Time

## TEST CIRCUITS



$\Delta V_O$  = measured voltage error due to charge injection  
 The charge injection in coulombs is  $Q = C_L \times \Delta V_O$

Figure 3. Charge Injection

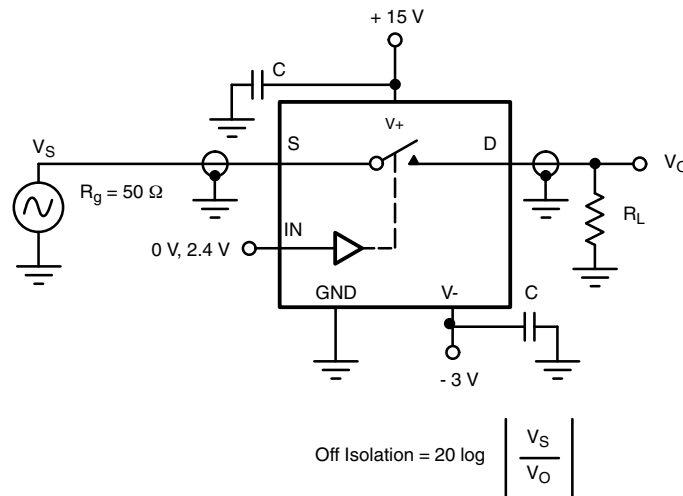

$$\text{Off Isolation} = 20 \log \left| \frac{V_S}{V_O} \right|$$

Figure 4. Off Isolation

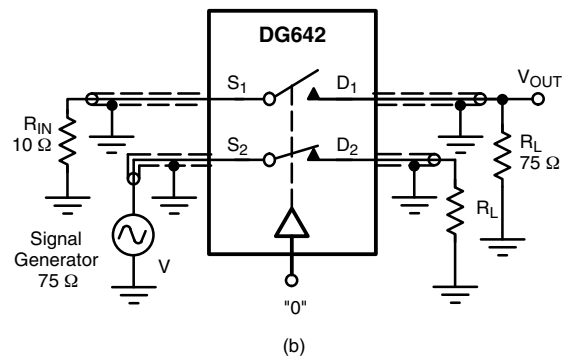
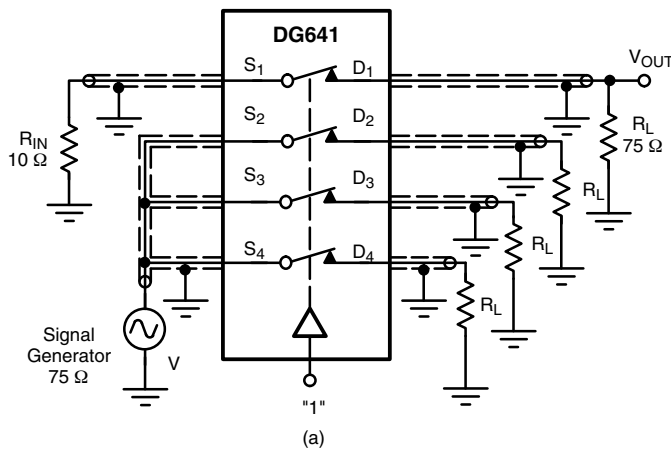

$$X_{\text{TALK(AH)}} = 20 \log_{10} \frac{V_{\text{OUT}}}{V}$$

Figure 5. All Hostile Crosstalk -  $X_{\text{TALK(AH)}}$

## TEST CIRCUITS

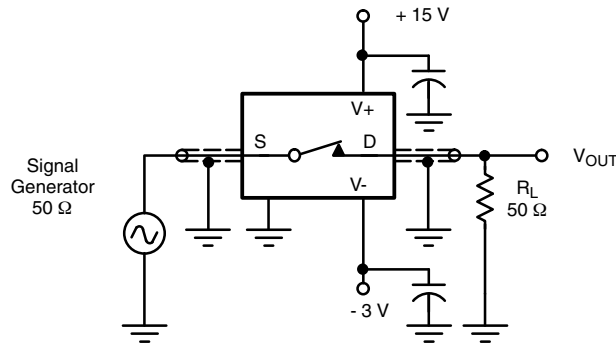

Figure 6. Bandwidth

## APPLICATIONS

### Device Description

The DG641, DG642, DG643 switches offer true bidirectional switching of high frequency analog or digital signals with minimum signal crosstalk, low insertion loss, and negligible non-linearity distortion and group delay.

Built on the Siliconix D/CMOS process, these switches provide excellent off-isolation with a bandwidth of around 500 MHz. The silicon-gate D/CMOS processing also yields fast switching speeds.

An on-chip regulator circuit maintains TTL input compatibility over the whole operating supply voltage range shown, easing control logic interfacing.

Circuit layout is facilitated by the interchangeability of source and drain terminals.

### Frequency Response

A single switch on-channel exhibits both resistance [ $R_{DS(on)}$ ] and capacitance [ $C_{S(on)}$ ]. This RC combination has an attenuation effect on the analog signal - which is frequency dependent (like an RC low-pass filter). The - 3 dB bandwidth of the DG641, DG642, DG643 is typically 500 MHz (into 50  $\Omega$ ).

### Power Supplies

Power supply flexibility is a useful feature of the DG641, DG642, DG643 series. It can be operated from a single positive supply ( $V_+$ ) if required ( $V_-$  connected to ground).

Note that the analog signal must not exceed  $V_-$  by more than - 0.3 V to prevent forward biasing the substrate p-n junction. The use of a  $V_-$  supply has a number of advantages:

1. It allows flexibility in analog signal handling, i.e., with  $V_- = -5$  V and  $V_+ = 12$  V; up to  $\pm 5$  V ac signals can be controlled.

2. The value of on capacitance [ $C_{S(on)}$ ] may be reduced. A property known as 'the body-effect' on the DMOS switch devices causes various parametric effects to occur. One of these effects is the reduction in  $C_{S(on)}$  for an increasing  $V$  body-source. Note however that to increase  $V_-$  normally requires  $V_+$  to be reduced (since  $V_+$  to  $V_- = 21$  V max.). A reduction in  $V_+$  causes an increase in  $r_{DS(on)}$ , hence a compromise has to be achieved. It is also useful to note that tests indicate that optimum video linearity performance (e.g., differential phase and gain) occurs when  $V_-$  is around - 3 V.
3.  $V_-$  eliminates the need to bias the analog signal using potential dividers and large coupling capacitors.

### Decoupling

It is an established rf design practice to incorporate sufficient bypass capacitors in the circuit to decouple the power supplies to all active devices in the circuit. The dynamic performance of the DG641, DG642, DG643 series is adversely affected by poor decoupling of power supply pins. Also, of even more significance, since the substrate of the device is connected to the negative supply, adequate decoupling of this pin is essential. Suitable decoupling capacitors are 1- to 10  $\mu$ F tantalum bead, plus 10- to 100-nF ceramic or polyester.

### Rules:

1. Decoupling capacitors should be incorporated on all power supply pins ( $V_+$ ,  $V_-$ ). (see figure 7).
2. They should be mounted as close as possible to the device pins.
3. Capacitors should be of a suitable type with good high frequency characteristics - tantalum bead and/or ceramic disc types are adequate.

## APPLICATIONS

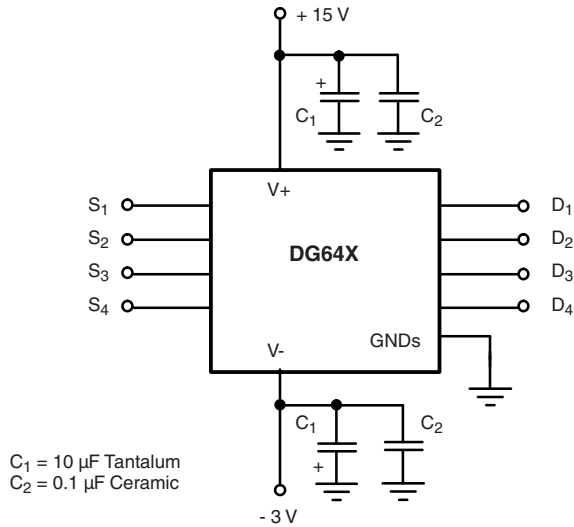

Figure 7. Supply Decoupling

### Board Layout

PCB layout rules for good high frequency performance must also be observed to achieve the performance boasted by these analog switches. Some tips for minimizing stray effects are:

1. Use extensive ground planes on double sided PCB, separating adjacent signal paths. Multilayer PCB is even better.
2. Keep signal paths as short as practically possible, with all channel paths of near equal length.
3. Careful arrangement of ground connections is also very important. Star connected system grounds eliminate signal current, flowing through ground path parasitic resistance, from coupling between channels.

Figure 8 shows a 4-channel video multiplexer using a DG641.

In Figure 9, two coax cables terminated on  $75 \Omega$  bring two video signals to the DG642 switch. The two drains tied together lower the on-state capacitance. An Si582 video amplifier drives a double terminated  $75 \Omega$  cable. The double terminated coax cable eliminates line reflections.

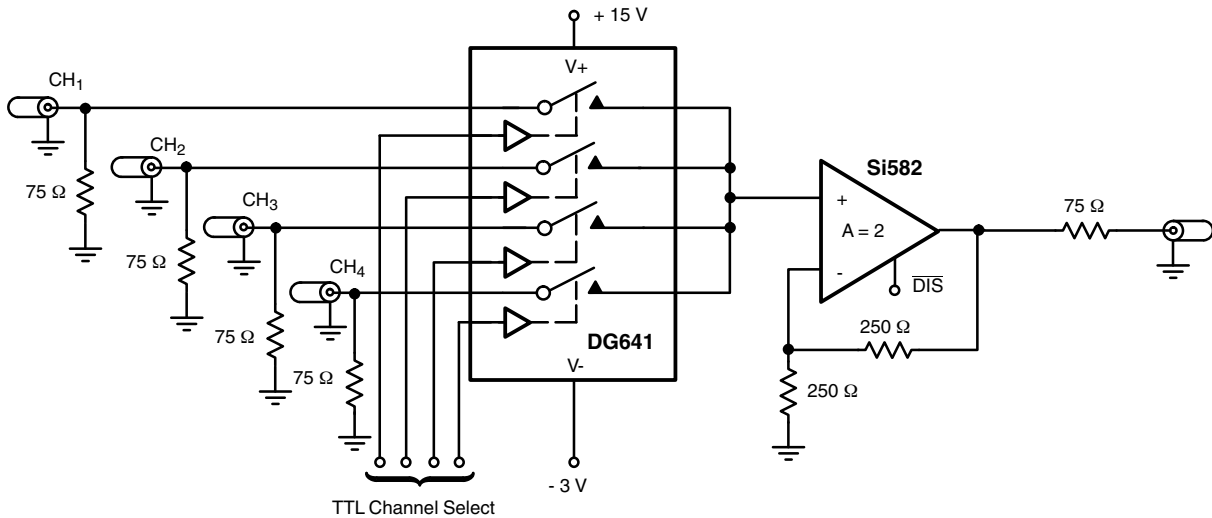

TTL Channel Select

Figure 8. 4 by 1 Video Multiplexing Using the DG641

## APPLICATIONS

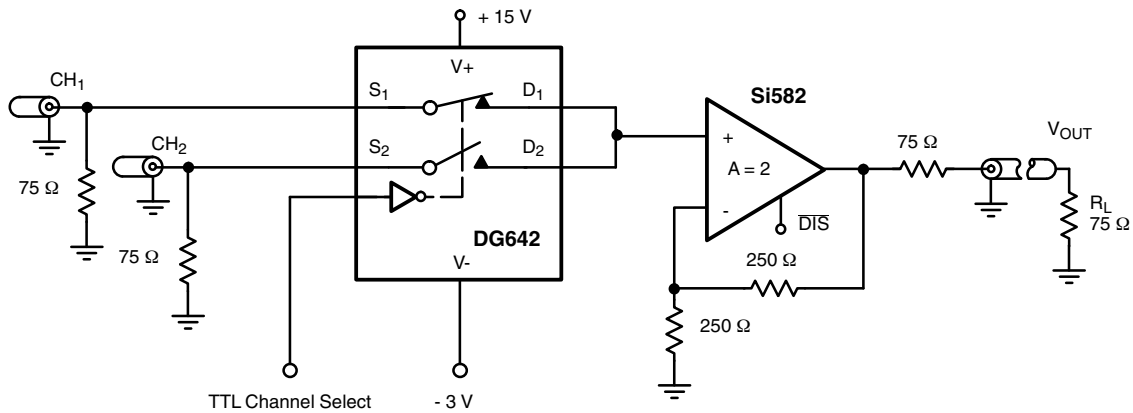

Figure 9. 2-Channel Video Selector Using the DG642

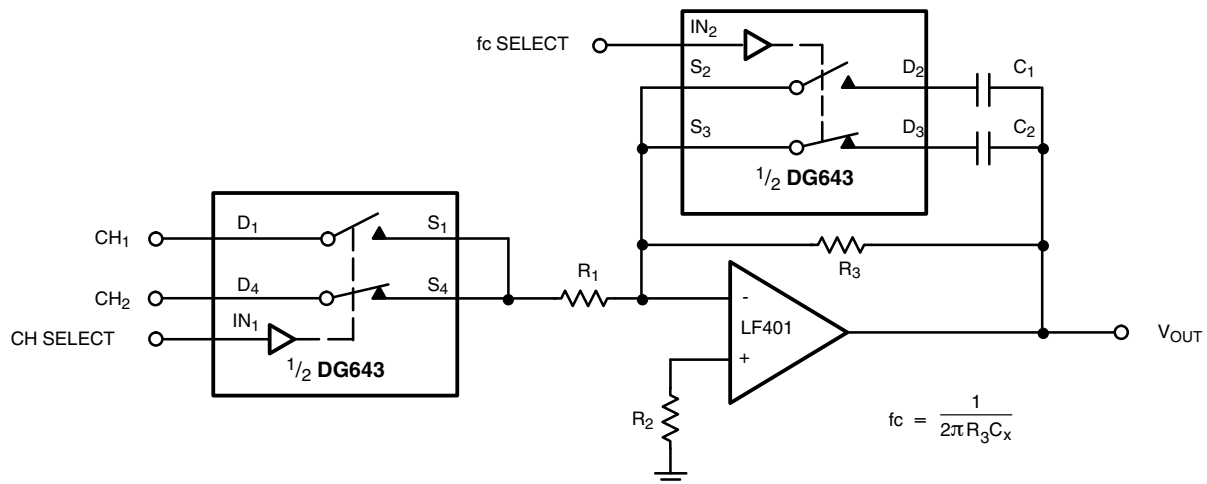
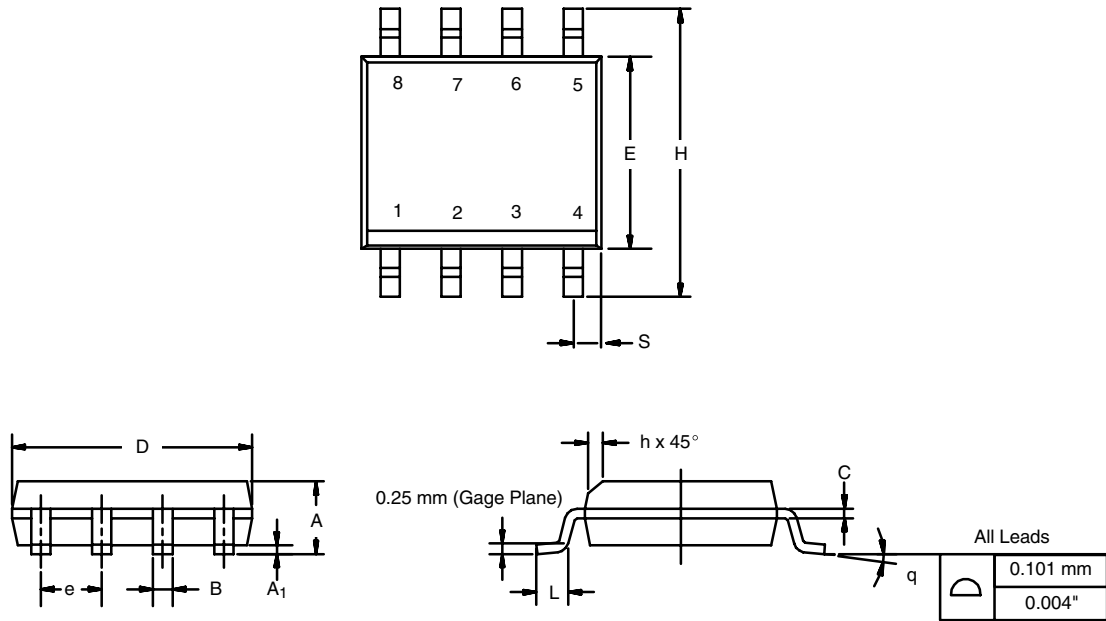

Figure 10. Active Low Pass Filter with Selectable Inputs and Break Frequencies

Vishay Siliconix maintains worldwide manufacturing capability. Products may be manufactured at one of several qualified locations. Reliability data for Silicon Technology and Package Reliability represent a composite of all qualified locations. For related documents such as package/tape drawings, part marking, and reliability data, see [www.vishay.com/ppg?70058](http://www.vishay.com/ppg?70058).

## SOIC (NARROW): 8-LEAD

JEDEC Part Number: MS-012



DIM	MILLIMETERS		INCHES	
	Min	Max	Min	Max
A	1.35	1.75	0.053	0.069
A <sub>1</sub>	0.10	0.20	0.004	0.008
B	0.35	0.51	0.014	0.020
C	0.19	0.25	0.0075	0.010
D	4.80	5.00	0.189	0.196
E	3.80	4.00	0.150	0.157
e	1.27 BSC		0.050 BSC	
H	5.80	6.20	0.228	0.244
h	0.25	0.50	0.010	0.020
L	0.50	0.93	0.020	0.037
q	0°	8°	0°	8°
S	0.44	0.64	0.018	0.026
ECN: C-06527-Rev. I, 11-Sep-06				
DWG: 5498				



**SOIC (NARROW): 16-LEAD**  
JEDEC Part Number: MS-012

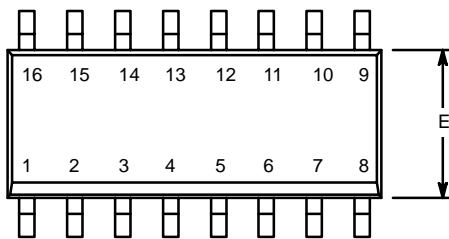

Dim	MILLIMETERS		INCHES	
	Min	Max	Min	Max
A	1.35	1.75	0.053	0.069
A <sub>1</sub>	0.10	0.20	0.004	0.008
B	0.38	0.51	0.015	0.020
C	0.18	0.23	0.007	0.009
D	9.80	10.00	0.385	0.393
E	3.80	4.00	0.149	0.157
e	1.27 BSC		0.050 BSC	
H	5.80	6.20	0.228	0.244
L	0.50	0.93	0.020	0.037
∅	0°	8°	0°	8°

ECN: S-03946—Rev. F, 09-Jul-01  
DWG: 5300

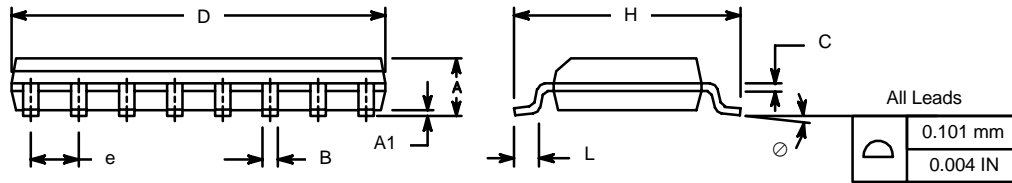



**PDIP: 8-LEAD**

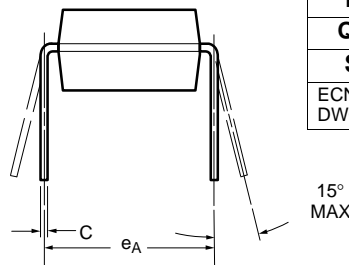
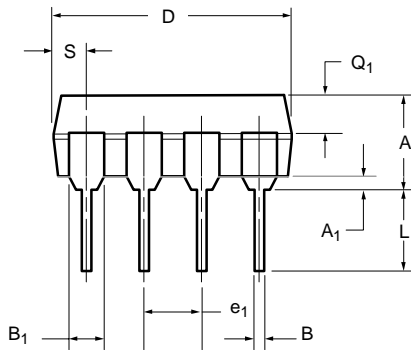
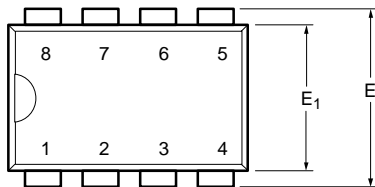

Dim	MILLIMETERS		INCHES	
	Min	Max	Min	Max
<b>A</b>	3.81	5.08	0.150	0.200
<b>A<sub>1</sub></b>	0.38	1.27	0.015	0.050
<b>B</b>	0.38	0.51	0.015	0.020
<b>B<sub>1</sub></b>	0.89	1.65	0.035	0.065
<b>C</b>	0.20	0.30	0.008	0.012
<b>D</b>	9.02	10.92	0.355	0.430
<b>E</b>	7.62	8.26	0.300	0.325
<b>E<sub>1</sub></b>	5.59	7.11	0.220	0.280
<b>e<sub>1</sub></b>	2.29	2.79	0.090	0.110
<b>e<sub>A</sub></b>	7.37	7.87	0.290	0.310
<b>L</b>	2.79	3.81	0.110	0.150
<b>Q<sub>1</sub></b>	1.27	2.03	0.050	0.080
<b>S</b>	0.76	1.65	0.030	0.065

ECN: S-03946—Rev. E, 09-Jul-01  
DWG: 5478

NOTE: End leads may be half leads.

### PDIP: 16-LEAD

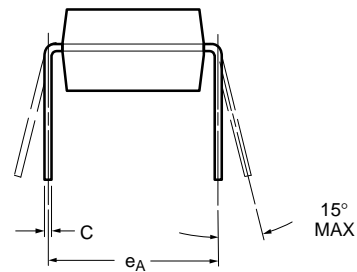
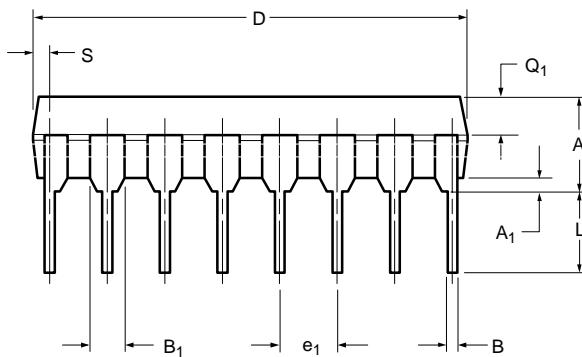
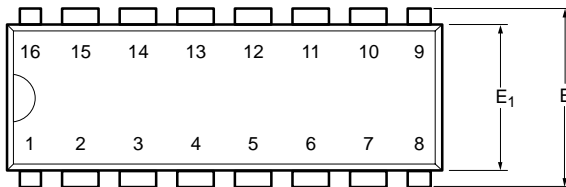

Dim	MILLIMETERS		INCHES	
	Min	Max	Min	Max
<b>A</b>	3.81	5.08	0.150	0.200
<b>A<sub>1</sub></b>	0.38	1.27	0.015	0.050
<b>B</b>	0.38	0.51	0.015	0.020
<b>B<sub>1</sub></b>	0.89	1.65	0.035	0.065
<b>C</b>	0.20	0.30	0.008	0.012
<b>D</b>	18.93	21.33	0.745	0.840
<b>E</b>	7.62	8.26	0.300	0.325
<b>E<sub>1</sub></b>	5.59	7.11	0.220	0.280
<b>e<sub>1</sub></b>	2.29	2.79	0.090	0.110
<b>e<sub>A</sub></b>	7.37	7.87	0.290	0.310
<b>L</b>	2.79	3.81	0.110	0.150
<b>Q<sub>1</sub></b>	1.27	2.03	0.050	0.080
<b>S</b>	0.38	1.52	.015	0.060

ECN: S-03946—Rev. D, 09-Jul-01  
DWG: 5482

## RECOMMENDED MINIMUM PADS FOR SO-8

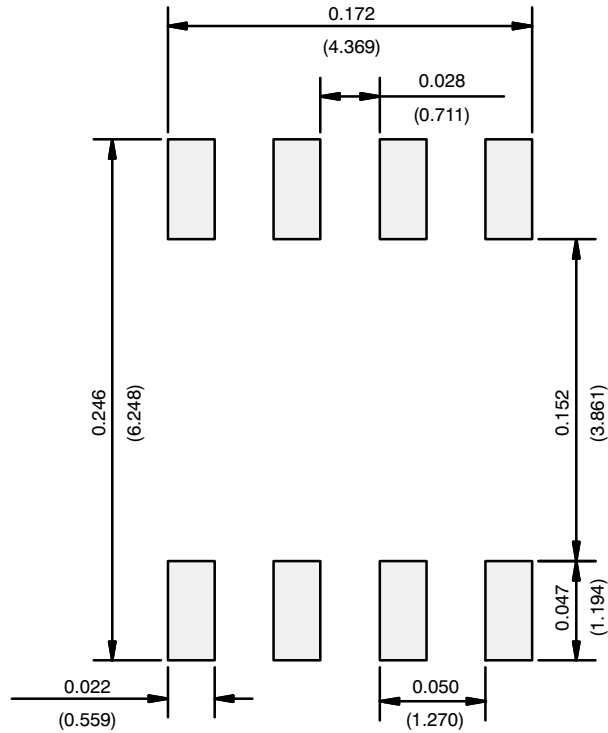

Recommended Minimum Pads  
Dimensions in Inches/(mm)

[Return to Index](#)

## RECOMMENDED MINIMUM PADS FOR SO-16

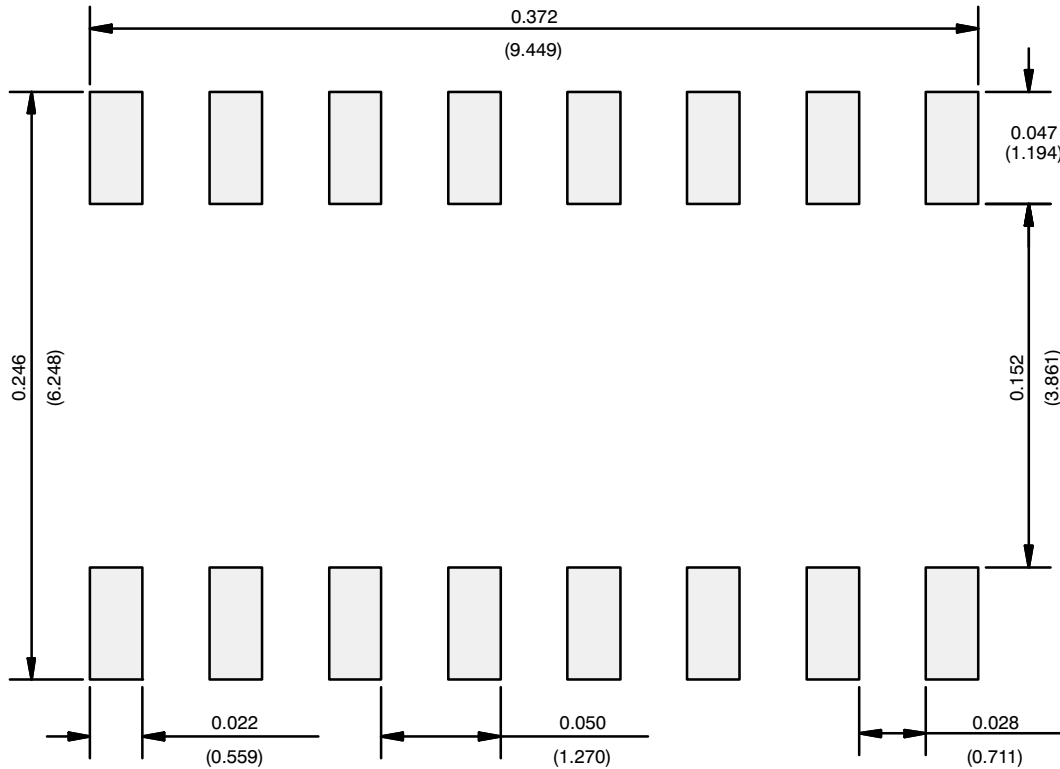

Recommended Minimum Pads  
Dimensions in Inches/(mm)

[Return to Index](#)



## Disclaimer

ALL PRODUCT, PRODUCT SPECIFICATIONS AND DATA ARE SUBJECT TO CHANGE WITHOUT NOTICE TO IMPROVE RELIABILITY, FUNCTION OR DESIGN OR OTHERWISE.

Vishay Intertechnology, Inc., its affiliates, agents, and employees, and all persons acting on its or their behalf (collectively, "Vishay"), disclaim any and all liability for any errors, inaccuracies or incompleteness contained in any datasheet or in any other disclosure relating to any product.

Vishay makes no warranty, representation or guarantee regarding the suitability of the products for any particular purpose or the continuing production of any product. To the maximum extent permitted by applicable law, Vishay disclaims (i) any and all liability arising out of the application or use of any product, (ii) any and all liability, including without limitation special, consequential or incidental damages, and (iii) any and all implied warranties, including warranties of fitness for particular purpose, non-infringement and merchantability.

Statements regarding the suitability of products for certain types of applications are based on Vishay's knowledge of typical requirements that are often placed on Vishay products in generic applications. Such statements are not binding statements about the suitability of products for a particular application. It is the customer's responsibility to validate that a particular product with the properties described in the product specification is suitable for use in a particular application. Parameters provided in datasheets and/or specifications may vary in different applications and performance may vary over time. All operating parameters, including typical parameters, must be validated for each customer application by the customer's technical experts. Product specifications do not expand or otherwise modify Vishay's terms and conditions of purchase, including but not limited to the warranty expressed therein.

Except as expressly indicated in writing, Vishay products are not designed for use in medical, life-saving, or life-sustaining applications or for any other application in which the failure of the Vishay product could result in personal injury or death. Customers using or selling Vishay products not expressly indicated for use in such applications do so at their own risk. Please contact authorized Vishay personnel to obtain written terms and conditions regarding products designed for such applications.

No license, express or implied, by estoppel or otherwise, to any intellectual property rights is granted by this document or by any conduct of Vishay. Product names and markings noted herein may be trademarks of their respective owners.

## Material Category Policy

**Vishay Intertechnology, Inc. hereby certifies that all its products that are identified as RoHS-Compliant fulfill the definitions and restrictions defined under Directive 2011/65/EU of The European Parliament and of the Council of June 8, 2011 on the restriction of the use of certain hazardous substances in electrical and electronic equipment (EEE) - recast, unless otherwise specified as non-compliant.**

**Please note that some Vishay documentation may still make reference to RoHS Directive 2002/95/EC. We confirm that all the products identified as being compliant to Directive 2002/95/EC conform to Directive 2011/65/EU.**

**Vishay Intertechnology, Inc. hereby certifies that all its products that are identified as Halogen-Free follow Halogen-Free requirements as per JEDEC JS709A standards. Please note that some Vishay documentation may still make reference to the IEC 61249-2-21 definition. We confirm that all the products identified as being compliant to IEC 61249-2-21 conform to JEDEC JS709A standards.**