



DATA SHEET

LIGHT ENGINE ACCESSORIES

INTRODUCTION: LIGHT ENGINE ACCESSORIES.....	3
HEAT SINK SELECTION AND ASSEMBLY RECOMMENDATIONS.....	3
ATLAS™ NT-4000 HEAT SINKS	
MECHANICAL SPECIFICATIONS AND COMPATIBILITY	4
THERMAL RESISTANCE.....	4
TEMPERATURE RISE OVER AMBIENT	4
TITAN™ NT-5000 HEAT SINK HS-5100-0346	
MECHANICAL SPECIFICATIONS	5
THERMAL RESISTANCE.....	5
TEMPERATURE RISE OVER AMBIENT	5
TITAN™ NT-5000 HEAT SINK HS-5200-0493	
MECHANICAL SPECIFICATIONS	6
THERMAL RESISTANCE.....	6
TEMPERATURE RISE OVER AMBIENT	6
TITAN TURBO™ NT-5000 HEAT SINKS	
MECHANICAL SPECIFICATIONS	7
THERMAL RESISTANCE.....	7
TEMPERATURE RISE OVER AMBIENT	8
OPTICS	
ATLAS NT-4000 OP-SERIES	
OPTICAL CHARACTERISTICS	8
OPTICAL PERFORMANCE, DAYLIGHT AND WARM.....	8
OPTICAL PERFORMANCE, RGB	8
NARROW OPTIC MECHANICAL DIMENSIONS	9
OPTIC RELATIVE LUMINOUS INTENSITY CURVES, DAYLIGHT AND WARM WHITE.....	9
TYPICAL ILLUMINANCE CHARACTERISTICS	10
RELATIVE LUMINOUS INTENSITY CURVES, RGB	10
TYPICAL ILLUMINANCE CHARACTERISTICS, RGB	11
TITAN NT-5000 OP-SERIES	
OPTICAL CHARACTERISTICS	11
OPTICAL PERFORMANCE, DAYLIGHT AND WARM WHITE.....	12
OPTICAL PERFORMANCE, RGB	12
OPTIC MECHANICAL DIMENSIONS & MOUNTING HOLE PATTERNS.....	13
OPTIC RELATIVE LUMINOUS INTENSITY CURVES	14
ILLUMINANCE CHARACTERISTICS	15
INTERCONNECTS	
ATLAS™ SOLDERING EZ-CONNECT BOARD TO LIGHT ENGINES	16
ATLAS™ NT-4000 EZ-CONNECT BOARD	17
ATLAS™ NT-4000 WIRING HARNESS.....	17
TITAN™ NT-5000 WIRING HARNESS.....	17
PATENTS, CONNECTIONS, ASSEMBLY, PACKAGING, AND NOTES.....	18
RoHS AND WARRANTY	18

TABLE OF CONTENTS

INTRODUCING LAMINA'S LIGHT ENGINE ACCESSORIES

Lamina® is pleased to offer you these accessories with our array of award winning LED products. These parts have been carefully chosen and developed to work with our LED light engines to help you quickly prove out your design and even go to market if you find them appropriate. Our Application Engineers are ready to help you select the right parts for your project. Please do not hesitate to give us a call as we are eager to work with you.

HEAT SINK SELECTION

Lamina's light engines should maintain LED die junction temperatures at or below maximum rated temperatures. Lamina's LED light engines provide very efficient transfer of heat from the individual LED die to the heat sink. Additionally, a heat sink with sufficient cooling capacity must be selected to maintain the LED die junction below the maximum rated temperature. Lamina's heat sinks have been sized for Lamina's standard products and to accommodate a range of desired operating conditions. Proper heat sink sizing is determined by a number of factors, including those listed below:

- Power Dissipated (Watts) - Determined by the light engine part number and associated drive parameters chosen for operating the LED Light Engine.
- Ambient Conditions - Ambient temperature, free or forced convection of air, etc.
- Thermal Path - Thermal interface material, light engine attachment method, surface area and conductivity of fixture housing the heat sink.
- Desired Lifetime and Lumen Maintenance - Lower LED junction temperatures result in longer lifetimes and higher light output over life. Increasing heat sink size will generally help to lower LED operating temperatures.
- Desired Light Output - LED luminous output is affected by the temperature at which the LEDs operate. Red and amber are more affected than blue, green and white. Increasing heat sink size will generally help to lower LED operating temperatures and result in higher light output.

Lamina® developed a selection of radial heat sinks to enable easy and rapid prototyping of designs with Lamina's light engines. These heat sinks have been designed to maximize the thermal performance of high brightness LED light engines while allowing design flexibility.

Lamina® heat sinks are:

- Designed for optimal thermal performance with Lamina's Atlas™ NT-4000 and Titan™ NT-5000 families of light engines

- Radial Shaped for design flexibility
- Drilled and tapped for ease of assembly
- Anodized for enhanced thermal performance
- Designed for a wide range of mounting positions

ASSEMBLY RECOMMENDATIONS

Lamina's light engines are designed to attach to heat sinks using screws with thermal grease in the joint or by using conductive epoxy. All Lamina® heat sinks are drilled and tapped to accept the recommended fasteners. More information on recommended attachment methods can be found in **Lamina's Connection Guide** for Lamina's LED Light Engines at www.laminalighting.com.



ATLAS™ HEAT SINK MECHANICAL SPECIFICATIONS

NT-4000

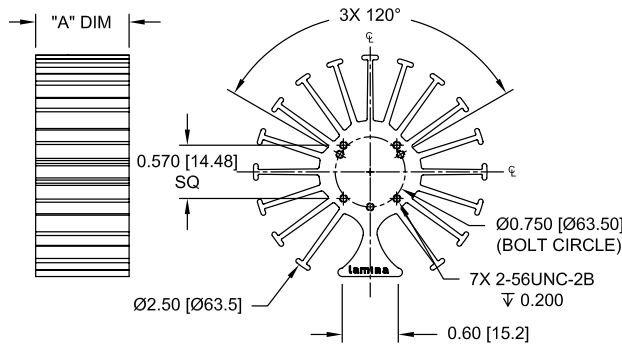

Figure 1. Lamina's heat sinks come in four different thicknesses ("A" Dimension), from 0.5" (12.7 mm) to 1.5" (38.1 mm) thick. Table 1 lists the applicable sizes for Lamina's standard Atlas™ NT-4000 products.

NT-4000 Heat Compatibility

Heat Sink Part Number	Dimension "A"
HS-4050-0345	0.5"
HS-4075-0345	0.75"
HS-4100-0345	1.0"
HS-4150-0345	1.5"

Table 1.

Note: 1. For the higher wattage red and amber light engines additional forced convection is necessary. Additional convection can be achieved by attaching a CPU style fan to the back of the heat sink, connecting the fan to the paddles of the heat sink.

Note 2. Applicable heat sinks when operated at rated LED light engine power, 25°C ambient and unrestricted convection.

ATLAS™ HEAT SINK THERMAL RESISTANCE

NT-4000

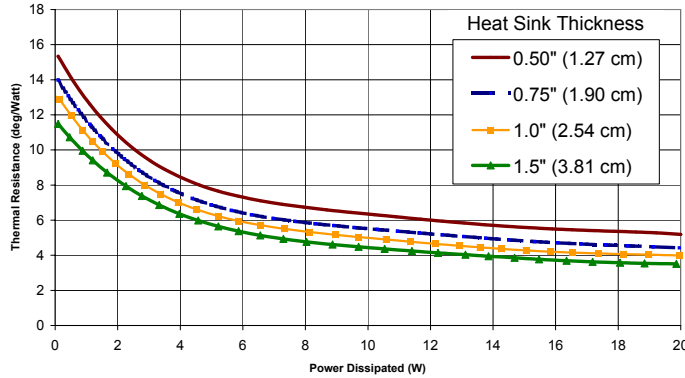

Figure 2.

ATLAS™ HEAT SINK TEMPERATURE RISE OVER AMBIENT

NT-4000

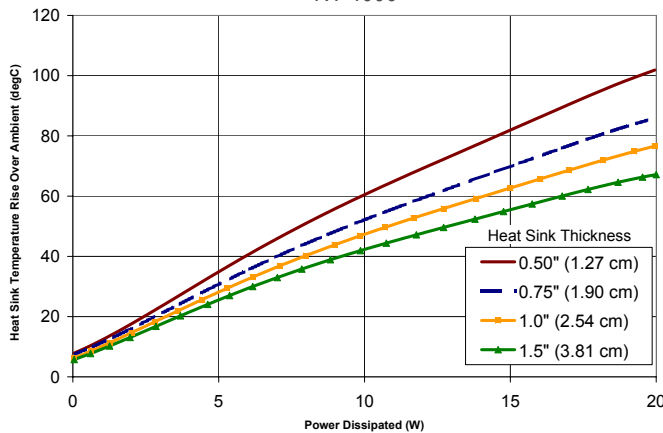

Figure 3.

TITAN™ HEAT SINK MECHANICAL SPECIFICATIONS

NT-5000 (HS-5100-0346)

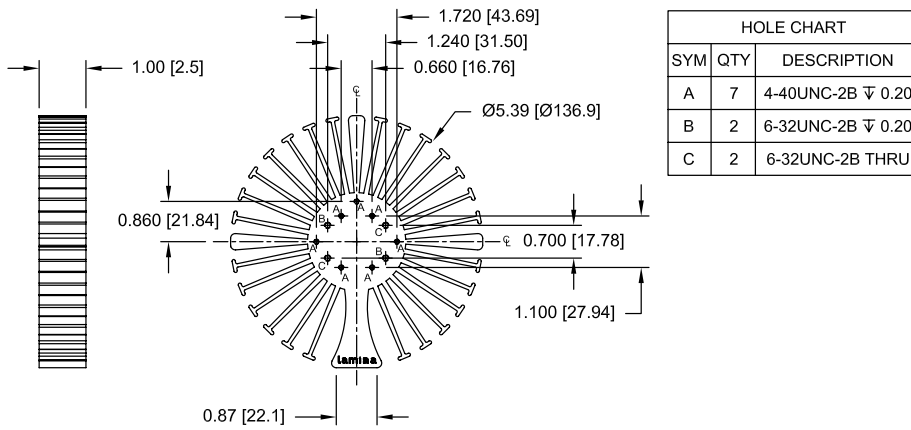

Figure 4.
Units: Inches [millimeters]

TITAN™ HEAT SINK THERMAL RESISTANCE

NT-5000 (HS-5100-0346)

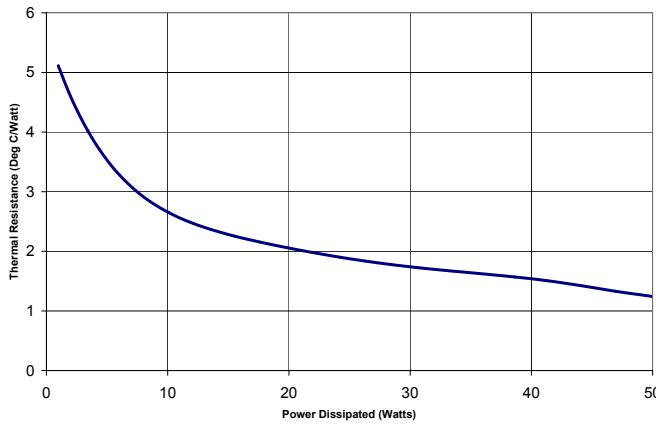

Figure 5.

TITAN™ HEAT SINK TEMPERATURE RISE OVER AMBIENT

NT-5000 (HS-5100-0346)

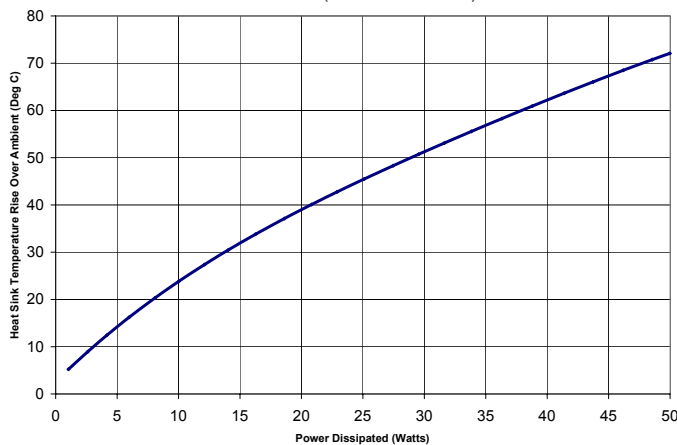

Figure 6.

TITAN™ HEAT SINK MECHANICAL SPECIFICATIONS

NT-5000 (HS-5200-0493)

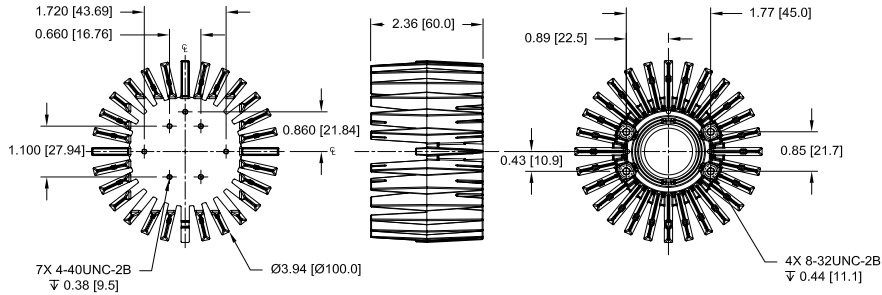

Figure 7.
Units: Inches [millimeters]

TITAN™ HEAT SINK THERMAL RESISTANCE

NT-5000 (HS-5200-0493)

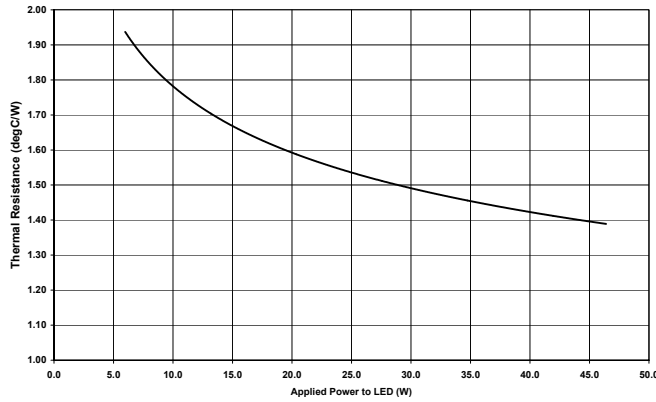

Figure 8.

TITAN™ HEAT SINK TEMPERATURE RISE OVER AMBIENT

NT-5000 (HS-5200-0493)

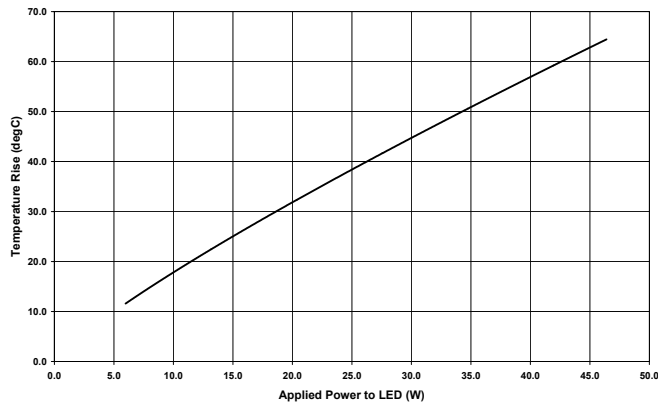

Figure 9.

TITANTURBO™ HEAT SINK TEMPERATURE RISE OVER AMBIENT

NT-5000 (HS-5410-0537), (HS-5430-0537), and (HS-543R-0537)

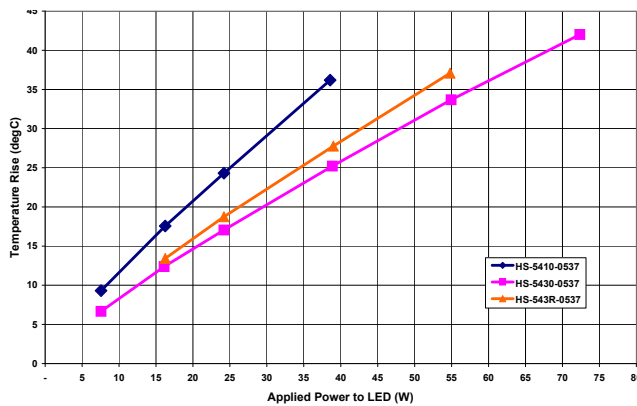

Figure 13.

ATLAS™ NT-4000 OP SERIES

Optical Characteristics

General Characteristics	
Lens Material	Optical Grade PMMA
Holder Material	PC ABS
Operating Ambient Temperature Range	-10°C / +80°C
Storage Temperature Range	-10°C / +80°C

Optical Performance Warm White (NT-42D1-0425) and Daylight White (NT-42D0-0426)

Lens Part Number	Type of Lens	Typical Total Beam Divergence ⁽¹⁾	Fig. #	Typ. Efficiency
OP-4LN2-0492	Narrow Beam	17°	9	75%
OP-4FM1-0442	Medium Beam	32°	10	86%
OP-4FW1-0441	Wide Beam	38°	10	84%

Optical Performance RGB (NT-43F0-0424)

Lens Part Number	Type of Lens	Typical Total Beam Divergence ⁽¹⁾	Fig. #	Typ. Efficiency
OP-4LN1-0457	Narrow Beam	17°	9	73%
OP-4FM1-0442	Medium Beam	34°	10	86%
OP-4FW1-0441	Wide Beam	38°	10	84%

Table 2. Lamina® now offers optics with narrow, medium and wide beam distributions designed for the Atlas product family. Lamina®, working with Fraen Corporation, has developed optics and optic holders based on Fraen's popular FHS series. Atlas optics are designed to produce homogeneous beam distributions with high collection efficiencies. The optic holders are designed to attach to Lamina's EZ-Connect Board.

Table 3. Notes: 1. The typical total divergence is the full angle measured where the luminous intensity is half of the peak value.

Table 4. Notes: 1. The typical total divergence is the full angle measured where the luminous intensity is half of the peak value.



ATLAS™ OPTIC MECHANICAL DIMENSIONS

NT-4000 Narrow (OP-4LN1-0457 and (OP-4LN2-0492)

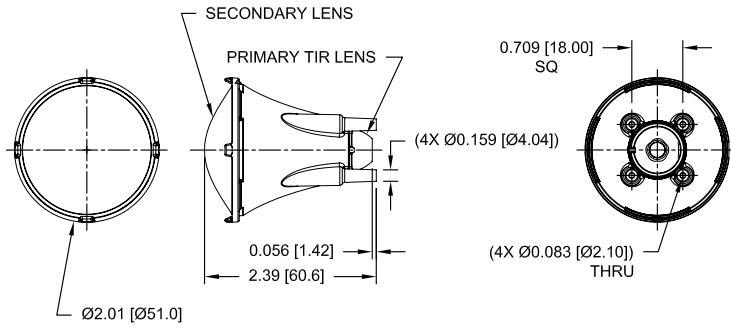

Figure 14.
 Units: Inches [millimeters]

NT-4000 Medium (OP-4FM1-0442) and
 Wide OP-4FW1-0441

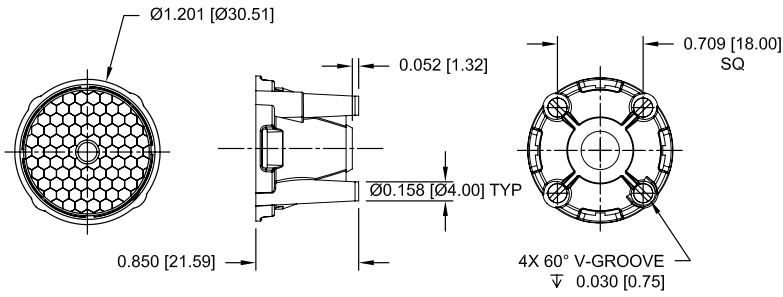

Figure 15.
 Units: Inches [millimeters]

ATLAS™ OPTIC RELATIVE LUMINOUS INTENSITY CURVE

Warm White (NT-42D1-0425) and Daylight White (NT-42D0-0426)

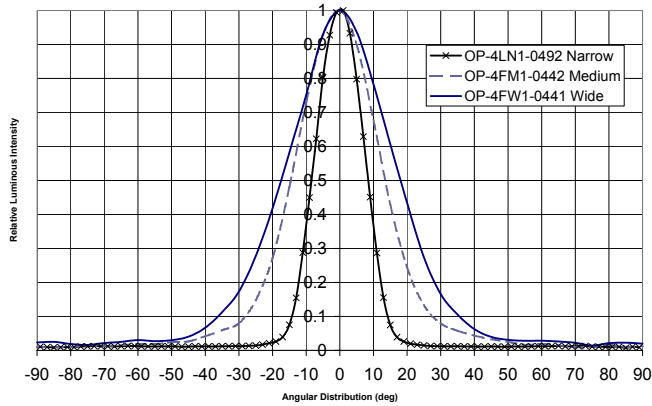

Figure 16.

Typical Illuminance Characteristics

Product	Drive Current (mA)	Illuminance (Lux)				Illuminance (fc)			
		Distance from Source [M]				Distance from Source [FT]			
		1	2	5	10	3.3	6.6	16.4	32.8
Warm White Light Engine - NT-42D1-0425									
OP-4LN2-0492 - Narrow	700	1228	307	49	12.3	114	29	5	1.1
	1050	1627	407	65	16.3	151	38	6	1.5
OP-4FM1-0442 - Medium	700	351	88	14	3.5	33	8	1	0.3
	1050	463	115	19	4.6	43	11	2	0.4
OP-4FW1-0441 - Wide	700	228	57	9	2.3	21	5	1	0.2
	1050	301	75	12	3.0	28	7	1	0.3
Daylight White Light Engine - NT-42D0-0426									
OP-4LN2-0492 - Narrow	700	1921	480	77	19.2	179	45	7	1.8
	1050	2435	609	97	24.4	225	57	9	2.3
OP-4FM1-0442 - Medium	700	549	137	22	5.5	51	13	2	0.5
	1050	696	174	28	7.0	65	16	3	0.6
OP-4FW1-0441 - Wide	700	356	89	14	3.6	33	8	1	0.3
	1050	452	113	18	4.5	42	11	2	0.4

Table 5.

ATLAS™ RELATIVE LUMINOUS INTENSITY CURVES

RGB (NT-43F0-0424) Light Engine with Narrow Optic

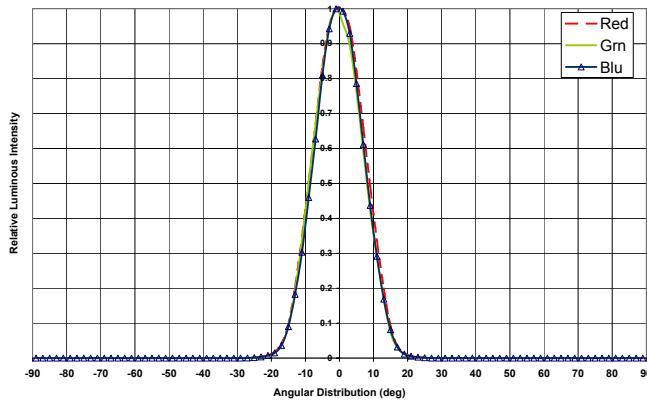

Figure 17.

ATLAS™ RELATIVE LUMINOUS INTENSITY CURVES

RGB (NT-43F0-0424) Light Engine with Medium Optic

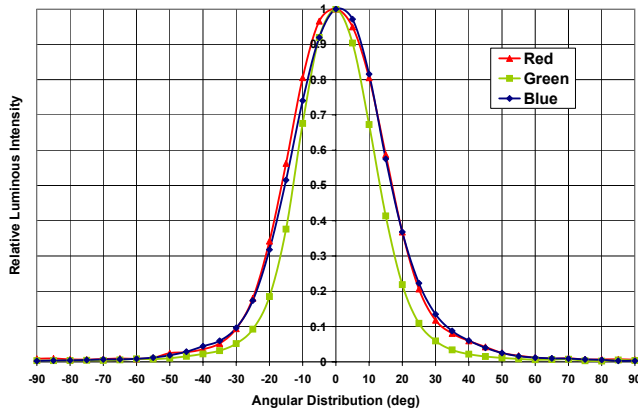

Figure 18.

ATLAS™ RELATIVE LUMINOUS INTENSITY CURVES

RGB (NT-43F0-0424) Light Engine with Wide Optic

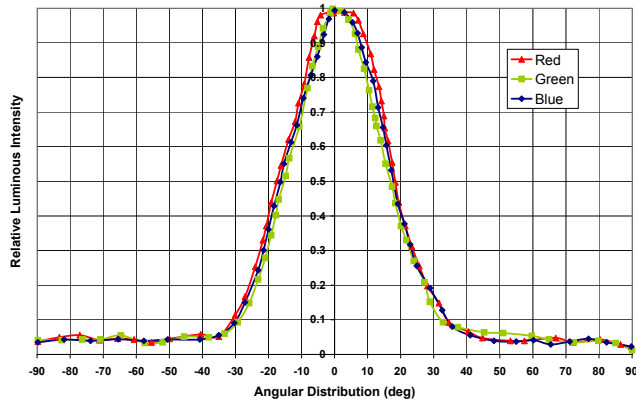

Figure 19.

Typical Illuminance Characteristics RGB (NT-43F0-0424) Light Engine

Product	Drive Current (mA)	Illuminance (Lux) Distance from Source [M]				Illuminance (fc) Distance from Source [F]			
		1	2	5	10	3.3	6.6	16.4	32.8
OP-4LN1-0457 Narrow									
Red	350	376	94	15	3.8	35	9	1	0.3
	525	545	136	22	5.4	51	13	2	0.5
Green	350	775	194	31	7.7	72	18	3	0.7
	525	1013	253	41	10.1	84	24	4	0.9
Blue	350	169	48	7	1.7	16	4	1	0.2
	525	233	58	9	2.3	22	5	1	0.2
OP-4FM1-0442 Medium									
Red	350	125	31	5	1.3	12	3	1	0.1
	525	183	46	7	1.8	17	4	1	0.2
Green	350	309	77	13	3.1	29	7	1	0.3
	525	402	100	16	4.0	37	9	2	0.4
Blue	350	53	13	2	0.5	5	1	0.2	0.0
	525	72	18	3	0.7	7	2	0.3	0.1
OP-4FW1-0441 Wide									
Red	350	116	29	5	1.2	11	3	0.4	0.1
	525	168	42	7	1.7	16	4	0.6	0.2
Green	350	146	37	6	1.5	14	3	0.5	0.1
	525	189	47	8	1.9	18	4	0.7	0.2
Blue	350	42	10	2	0.4	4	1	0.2	0.0
	525	59	15	2	0.6	6	1	0.2	0.1

Table 6.

TITAN™ NT-5000 OPTIC - OP SERIES

Lamina's Titan™ Series is available in 3050K Warm White, 4700K Daylight White and RGB. The Titan 3050K Warm White delivers 600+ lumens from a single point. Enhanced red and orange color spectrum and a CRI of 80 make this product ideal for incandescent and halogen replacements. The Titan RGB, through three independently controlled input and output channels (red, green and blue), produces any of 16,000,000 beautifully saturated and blended colors (including white with variable color temperature) from a single point source.

Lamina® now offers optics with narrow, medium, and wide beam distributions designed for the NT-5000 product family. The optics were designed in collaboration with Transducin Optics, LLC.

Each optic is supplied with an optic mount that is compatible with Lamina® heat sinks, interchangeable lens for medium and wide beam, and assembly instructions.

Optical Characteristics

General Characteristics	
Lens Material	Optical Grade PMMA
Holder Material	ABS
Operating Ambient Temperature Range	-10°C / +50°C
Storage Temperature Range	-10°C / +50°C

Table 7.

Optical Performance Warm White (NT-52D0-0429) and Daylight White (NT-52D1-0430)

Lens Part Number	Type of Lens	Typical Total Beam Divergence ⁽¹⁾	Figure #	Typ. Efficiency
OP-5LN1-0451	Narrow Beam	9	16	72%
OP-5LN2-0445	Narrow	24	15	82%
OP-5LM3-0455	Medium Beam	35	15	82%
OP-5LW4-0456	Wide Beam	48	15	82%
OP-5LN1-0499	Narrow Beam	11	18	70%

Table 8.

Notes: 1. The typical total divergence is the full angle measured where the luminous intensity is half of the peak value.

Optical Performance, RGB (NT-53F0-0428)

Lens Part Number	Type of Lens	Typical Total Beam Divergence ⁽¹⁾	Figure #	Typ. Efficiency
OP-5LN2-0445	Narrow	24	15	82%
OP-5LM3-0455	Medium Beam	35	15	82%
OP-5LW4-0456	Wide Beam	48	15	82%
OP-5LN1-0499	Narrow Beam	11	18	70%

Table 9.

Notes: 1. The typical total divergence is the full angle measured where the luminous intensity is half of the peak value.

TITAN™ OPTIC MECHANICAL DIMENSIONS

OP-5LN2-0445, OP-5LM3-0455 and OP-5LW-0456

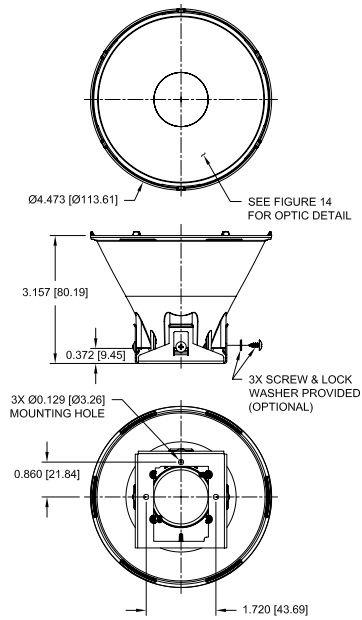

Figure 20.

OP-5LN1-0451

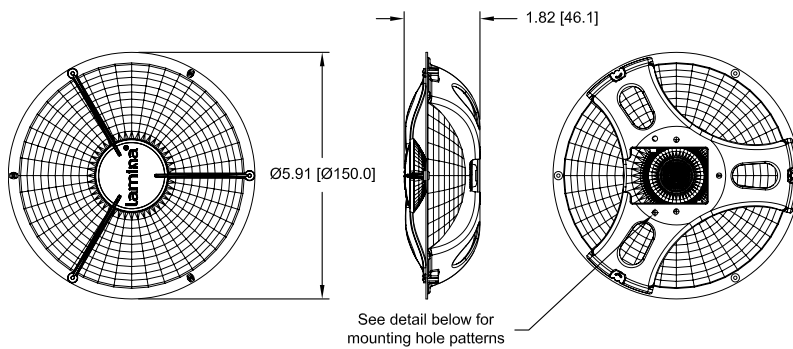

Figure 21.

Mounting Hole Patterns OP-5LN1-0451

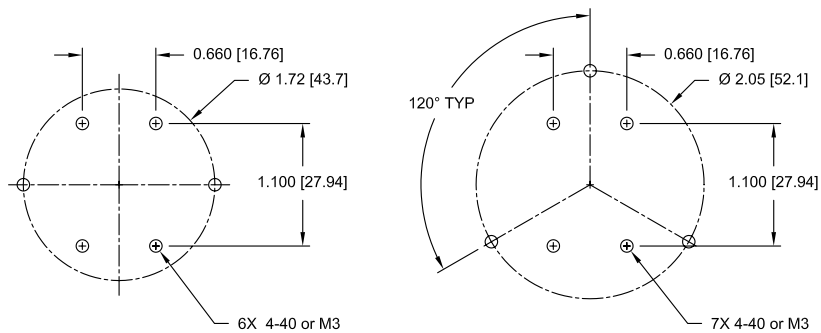

Figure 22.

TITAN™ OPTIC MECHANICAL DIMENSIONS

OP-5LN1-0499

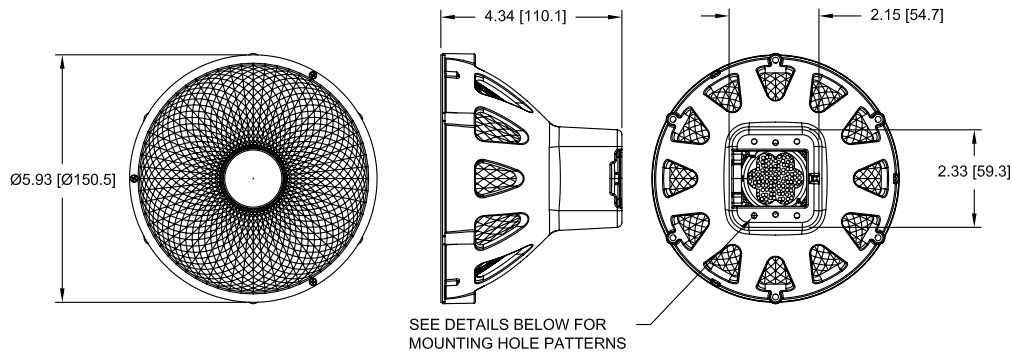

Figure 23.

Mounting Hole Patterns OP-5LN1-0499

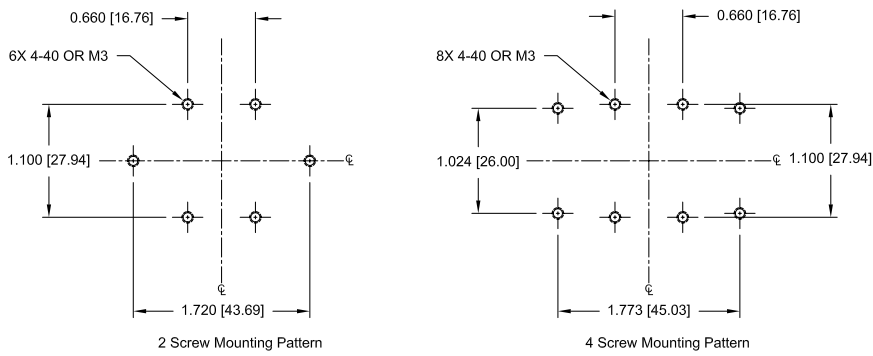

Figure 24.

TITAN™ RELATIVE LUMINOUS INTENSITY CURVES

Warm White (NT-52D1-0430) and
Daylight White (NT-52D0-0429) Optics

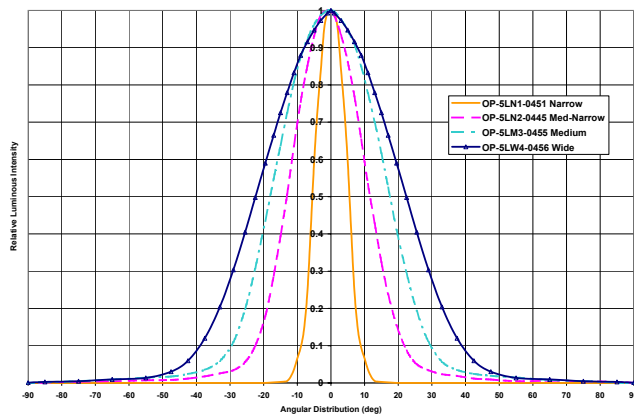

Figure 25.

OP-5LN2-0445 MED-NARROW LUMINOUS INTENSITY CURVES

RGB Optic (NT-53F0-0428)

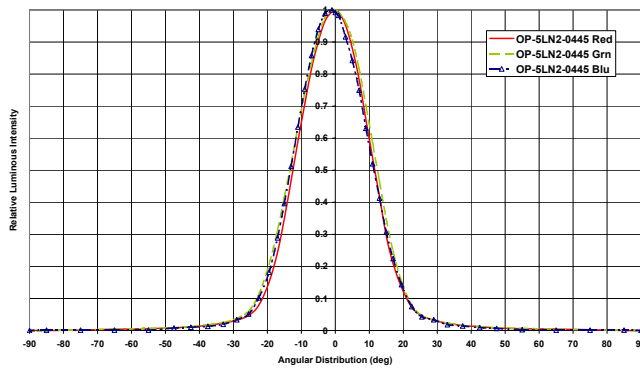

Figure 26.

OP-5LW4-0446 WIDE LUMINOUS INTENSITY CURVES

RGB Optic (NT-53F0-0428)

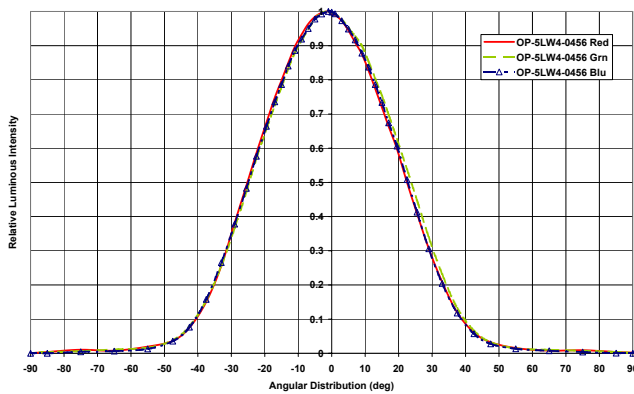

Figure 27.

TITAN™ TYPICAL ILLUMINANCE CHARACTERISTICS

Narrow Optic OP-5LN1-0451

Part Number	Color	Drive Current (mA)	Illuminance (Lux)				Illuminance (fc)			
			Distance from Source [M]				Distance from Source [F]			
			1	2	5	10	3.3	6.6	16.4	32.8
NT-52D1-0430	Warm White	1050	3592	898	144	36	334	83	13	3
		1400	4621	1155	185	46	429	107	17	4
NT-52D0-0429	Daylight White	1050	5340	1335	214	53	496	124	20	5
		1400	6336	1584	254	63	589	147	24	6

Table 10.

Narrow Optic OP-5LN2-0445

Part Number	Color	Drive Current (mA)	Illuminance (Lux)				Illuminance (fc)			
			Distance from Source [M]				Distance from Source [F]			
			1	2	5	10	3.3	6.6	16.4	32.8
NT-52D1-0430	Warm White	1050	2602	551	108	26	242	60	10	2.4
		1400	3447	862	138	35	320	80	13	3.2
NT-52D0-0429	Daylight White	1050	3871	968	155	39	360	90	14	3.6
		1400	4594	1149	184	46	427	107	17	4.3
NT-53F0-0428	RGB, Red	1050	1098	275	44	11	102	26	4	1.0
		1400	1571	393	63	16	146	37	6	1.5
	RGB, Green	1050	1769	442	71	18	164	41	7	1.6
		1400	2298	575	92	23	214	53	9	2.1
	RGB, Blue	1050	507	127	20	5	47	12	2	0.5
		1400	690	173	28	7	64	16	3	0.6

Table 11.

Medium Optic OP-5LM3-0455

Part Number	Color	Drive Current (mA)	Illuminance (Lux)				Illuminance (fc)			
			Distance from Source [M]				Distance from Source [F]			
			1	2	5	10	3.3	6.6	16.4	32.8
NT-52D1-0430	Warm White	1050	1408	352	56	14	131	33	5	1.3
		1400	1864	466	75	19	173	43	7	1.7
NT-52D0-0429	Daylight White	1050	2094	523	84	21	195	47	8	1.9
		1400	2485	621	100	25	231	58	9	2.3
NT-53F0-0428	RGB, Red	1050	552	138	22	5.5	51	13	2	0.5
		1400	789	197	32	7.9	73	18	3	0.7
	RGB, Green	1050	934	234	37	9.3	87	22	4	0.9
		1400	1214	304	49	12.1	113	28	5	1.1
	RGB, Blue	1050	247	62	10	2.5	23	6	1	0.2
		1400	336	84	14	3.4	31	8	1	0.3

Table 12.

Wide Optic OP-5LW4-0456

Product	Color	Drive Current (mA)	Illuminance (Lux)				Illuminance (fc)			
			Distance from Source [M]				Distance from Source [F]			
			1	2	5	10	3.3	6.6	16.4	32.8
NT-52D1-0430	Warm White	1050	924	231	37	9.2	86	22	3	0.9
		1400	1224	306	49	12.2	114	28	5	1.1
NT-52D0-0429	Daylight White	1050	1374	344	55	13.7	128	32	5	1.3
		1400	1631	408	65	16.3	152	38	6	1.5
NT-53F0-0428	RGB, Red	1050	357	89	14	3.6	33	8	1	0.3
		1400	510	128	20	5.1	47	12	2	0.5
	RGB, Green	1050	585	234	37	5.8	54	14	2	0.5
		1400	760	190	30	7.6	71	18	3	0.7
	RGB, Blue	1050	162	40	7	1.6	15	4	1	0.2
		1400	220	55	9	2.2	20	5	1	0.2

Table 13.

ATLAS™ NT-4000 SOLDERING EZ-CONNECT BOARD TO LAMINA'S LIGHT ENGINES

Electrical connections may be made between a PWB and Atlas™ products with lead free solder (Sn96/Ag3.5/Cu0.5) using localized heating on the Atlas™ terminals.

- Mounting holes for Lamina® Optics
- Standard AMP connector
- Mating color coded wiring harness available

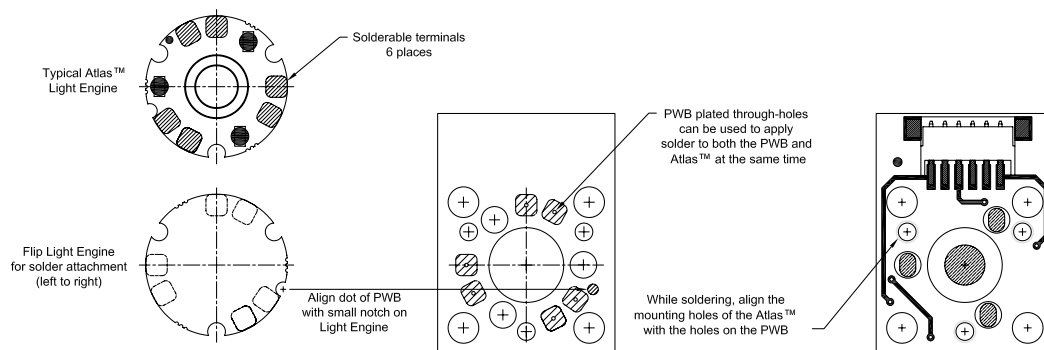

Figure 28.

ATLAS™ EZ-CONNECT BOARD

NT-4000 EZ-CONNECT BOARD (EZ-4000-0357)

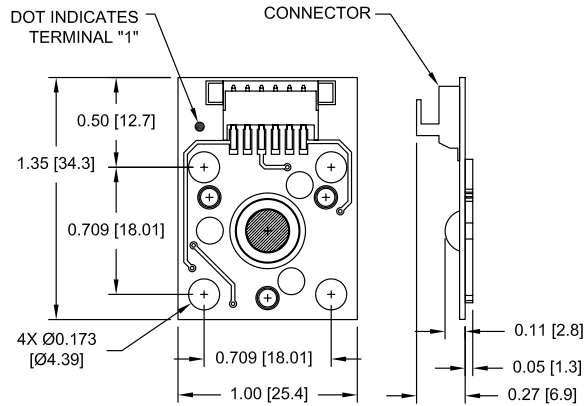

Figure 29.

ATLAS™ AND TITAN™ WIRING HARNESSSES

Atlas™ NT-4000 EZ-Connect Wiring Harness (EZ-46WH-0345)

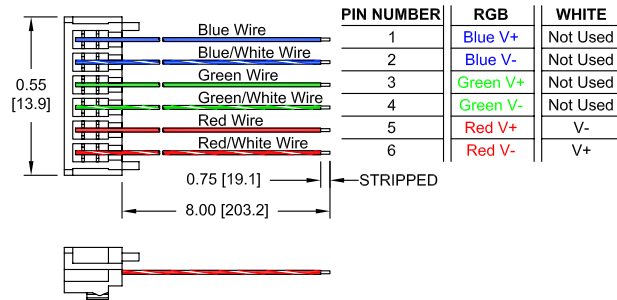

Figure 30.
Units: Inches [millimeters]

The same wire harness is used for RGB and White parts. Connector reference AMP P/N 173977-6.

Titan™ NT-5000 EZ-46WH-0354

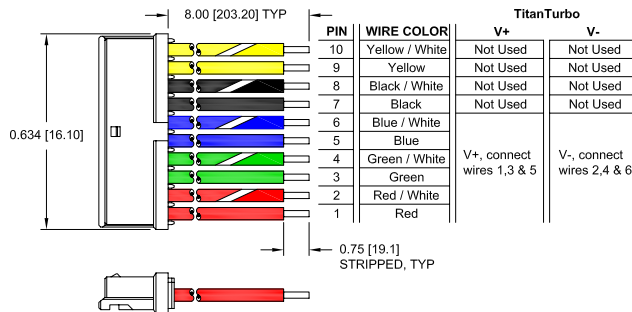

Figure 31.
Units: Inches [millimeters]
The same wire harness is used for RGB and White parts. Connector reference Molex Header 87438-1043 and Crimp Terminal 87421-0000.

PATENTS, CONNECTIONS, ASSEMBLY, AND PACKAGING

PATENTS

Lamina's light engines may be covered by pending patents and/or one or more of the following U.S. and/or International patents 5876536, 6709749 B, 595880, 6017642, 5565262, 5681444, 5653834, 5581876, 5847935, 5514451, 5747931, 5925203, 5725808, 5929510, 5858145, 5866240, 5953203, 6055151, 614076, 6011330, 6399230, 6914501, 6168490, 6191934, 614075, 6160469, 6300267, 6471805, 6518502, 6739047, 6720859, 6759940, 6518502, 6670856 B1, 6720859, 6713862 B2, WO 00/47399, WO 00/26152, WO 98/19339, 5082804, ZL99808762.9, 69623930, 69628549, 69629572, 805785, 69628549, 843621, 932500, 805785, 812258, 843621, 932500, 805785, 812258, 843621, 932500, 3327556, 3267299, 3226281, 3405545, 320630, 295695, 284068, 546471, 805785, 812258, 843621, 6455930, 6759940, 6713862, 7095053 7098483.

ELECTRICAL CONNECTIONS

The LED light engines are available with or without Lamina's EZ-Connect Board. EZ-Connect adapter boards have AMP connectors for solderless connections to Lamina's wiring harness.

As with many electrical devices, RMA type solder flux should be used to prepare the solder pads before application of solder. Ensure proper strain relief of wires attached to the light engine to prevent damage to the light engines solder pads. For more information refer to Lamina's Connection application note AN-05 which can be found on the website at www.laminalighting.com.

Functional test: Parts may be tested using a constant current source set at 25% of specified drive current specified per specification, drawing or datasheet for no more than two seconds without heat sink. Voltage compliance of power source should not exceed forward voltage plus 5 volts.

1. Optical and electrical specifications are given for the specified drive @ 25°C junction temperature.
2. When using constant current LED drivers with high compliance voltage (Advance, LEDworks, etc. or a custom driver) the output of the supply must be connected to the part before power is applied to the input of the supply.

ASSEMBLY RECOMMENDATIONS

Lamina's Light Engines are designed for attachment to a heat sink with conductive epoxy or thermal grease in the joint. For attachment using screws, a 2-56 UNC round head or metric equivalent M2 X 0.4 cheese head screw, 18-8 SS is recommended. When mounting the light engine, position the three screws in the center of each of the three slots. Tighten the three screws evenly, first to about 0.89 inch pounds (10 Newton-centimeter), and then tighten each to a maximum torque of 4 inch pounds (45 Newton-centimeter). Flatness requirement of the surface that the light engine is mounted to is 0.001 inch/inch (1mm/meter).

PACKAGING - RECEIVING PARTS AND PACKAGING TRAYS

Your parts will arrive in either custom fitted trays or bulk packaging when appropriate. This packaging was designed or specified to provide the necessary protection during shipment and to take up the least amount of space in your storage area.

NOTES

1. These products use silicone materials for superior optical performance. Do not expose the part to fluids that may react with silicone compounds. See Dow Chemical Form 45-0113D-01, Silicone Fluid Resistance Guide.
2. Ray trace models are available upon request.
3. Lamina® may make process or materials changes affecting the performance or other characteristics of our products. The products supplied after such changes will continue to meet published specifications, but may not be identical to product supplied as samples or under prior orders.
4. All specifications are based on mounting the LED array to a heat sink using the specified hardware and thermal grease (e.g. Wakefield P/N 120). The heat sink must meet the specified flatness requirement. Mounting using screws and thermal tape may damage the device.



RoHS AND WARRANTY

LAMINA LIGHT ENGINES COMPLY WITH RoHS RESTRICTIONS

Lamina Light Engines are compliant with all of the criteria proposed by the European RoHS Directive 2002/95/EC for hazardous material content in electronic and electrical equipment as listed in Annex 1A and 1B of the WEEE Directive.

In addition to containing no mercury, Lamina's LED Light Engines have the following environmental advantages over traditional light sources:

- High energy efficiency
- Long lifetime
- Fully dimmable
- Very low IR and UV radiation

For attachment of electrical connections Lamina recommends the use of lead-free solder.



WARRANTY STATEMENT

Lamina Lighting, Incorporated (Seller) extends warranty on goods produced by the Seller for one (1) year from original date of shipment, that the goods sold hereunder are new and free from substantive defects in workmanship and materials. This warranty extends only to the Buyer and not to indirect purchasers or users. Seller's liability under the foregoing warranty is limited to replacement of goods or repair of defects or refund of the purchase price at the Seller's sole option. The above warranty does not apply to defects resulting from the improper or inadequate maintenance, unauthorized modification, improper use or operation outside of Seller's specifications for the product, abuse, neglect or accident. THE ABOVE WARRANTY IS EXCLUSIVE AND NO OTHER WARRANTY, WHETHER WRITTEN OR ORAL, IS EXPRESSED OR IMPLIED. LAMINA LIGHTING INCORPORATED SPECIFICALLY DISCLAIMS THE IMPLIED WARRANTIES OF MERCHANTABILITY AND FITNESS FOR A PARTICULAR PURPOSE. - LAMINA LIGHTING INCORPORATED - June 21, 2006.

©2008 Lamina Lighting Incorporated. Lamina is a registered trademark and the Lamina logo, Atlas, Titan, TitanTurbo, SöL, TruColor, and E-ZConnect are trademarks of Lamina Lighting Incorporated. All other trademarks mentioned are the property of their respective owners.

Mouser Electronics

Authorized Distributor

Click to View Pricing, Inventory, Delivery & Lifecycle Information:

[Lighting Science Group:](#)

[EZ-4000-0357](#)