

GSS4953

P-CHANNEL ENHANCEMENT MODE POWER MOSFET

BV _{DSS}	-30V
R _{DS(ON)}	53mΩ
I _D	-5A

Description

The GSS4953 provide the designer with the best combination of fast switching, ruggedized device design, low on-resistance and cost-effectiveness.

The SOP-8 package is universally preferred for all commercial-industrial surface mount applications and suited for low voltage applications such as DC/DC converters.

Features

- *Simple Drive Requirement
- *Lower On-resistance
- *Fast Switching

Package Dimensions

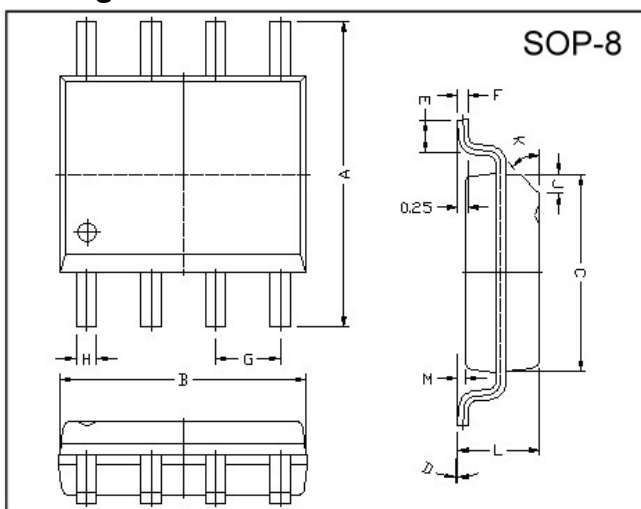

Marking :

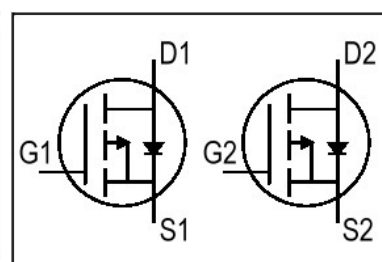
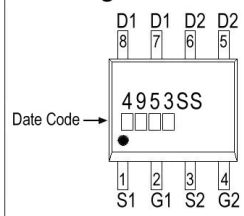

REF.	Millimeter		REF.	Millimeter	
	Min.	Max.		Min.	Max.
A	5.80	6.20	M	0.10	0.25
B	4.80	5.00	H	0.35	0.49
C	3.80	4.00	L	1.35	1.75
D	0°	8°	J	0.375 REF.	
E	0.40	0.90	K	45°	
F	0.19	0.25	G	1.27 TYP.	

Absolute Maximum Ratings

Parameter	Symbol	Ratings	Unit
Drain-Source Voltage	V _{DS}	-30	V
Gate-Source Voltage	V _{GS}	±16	V
Continuous Drain Current ¹	I _D @TA=25°C	-5	A
Continuous Drain Current ¹	I _D @TA=70°C	-4	A
Pulsed Drain Current ²	I _{DM}	-20	A
Total Power Dissipation ¹	P _D @TA=25°C	2	W
Linear Derating Factor		0.02	W/°C
Operating Junction and Storage Temperature Range	T _j , T _{stg}	-55 ~ +150	°C

Thermal Data

Parameter	Symbol	Value	Unit
Thermal Resistance Junction-ambient ¹ Max.	R _{thj-amb}	62.5	°C/W

Electrical Characteristics ($T_j = 25^\circ\text{C}$ unless otherwise specified)

Parameter	Symbol	Min.	Typ.	Max.	Unit	Test Conditions
Drain-Source Breakdown Voltage	BV_{DSS}	-30	-	-	V	$V_{GS}=0, I_D=-250\mu\text{A}$
Gate Threshold Voltage	$V_{GS(th)}$	-1.0	-	-2.5	V	$V_{DS}=V_{GS}, I_D=-250\mu\text{A}$
Forward Transconductance ²	g_{fs}	-	5	-	S	$V_{DS}=-5\text{V}, I_D=-5\text{A}$
Gate-Source Leakage Current	I_{GSS}	-	-	± 100	nA	$V_{GS} = \pm 16\text{V}$
Drain-Source Leakage Current	I_{DSS}	-	-	-1	μA	$V_{DS}=-24\text{V}, V_{GS}=0$
Static Drain-Source On-Resistance ²	$R_{DS(ON)}$	-	-	53	m Ω	$V_{GS}=-10\text{V}, I_D=-5\text{A}$
		-	-	90		$V_{GS}=-4.5\text{V}, I_D=-4\text{A}$
Total Gate Charge ²	Q_g	-	11.7	-	nC	$I_D=-5\text{A}$ $V_{DS}=-15\text{V}$ $V_{GS}=-10\text{V}$
Gate-Source Charge	Q_{gs}	-	2.1	-		
Gate-Drain ("Miller") Change	Q_{gd}	-	2.9	-		
Turn-on Delay Time ²	$T_{d(on)}$	-	9	-	ns	$V_{DS}=-15\text{V}$ $I_D=-1\text{A}$ $V_{GS}=-10\text{V}$ $R_G=6\Omega$ $R_D=15\Omega$
Rise Time	T_r	-	10	-		
Turn-off Delay Time	$T_{d(off)}$	-	37	-		
Fall Time	T_f	-	23	-		
Input Capacitance	C_{iss}	-	582	-	pF	$V_{GS}=0\text{V}$ $V_{DS}=-15\text{V}$ $f=1.0\text{MHz}$
Output Capacitance	C_{oss}	-	125	-		
Reverse Transfer Capacitance	C_{rss}	-	86	-		

Source-Drain Diode

Parameter	Symbol	Min.	Typ.	Max.	Unit	Test Conditions
Forward On Voltage ²	V_{SD}	-	-0.84	-1.2	V	$I_S=-1.7\text{A}, V_{GS}=0\text{V}$

Notes: 1. Surface Mounted on FR4 Board, $t \leq 10\text{sec}$.

2. Pulse width $\leq 300\mu\text{s}$, duty cycle $\leq 2\%$.

Characteristics Curve

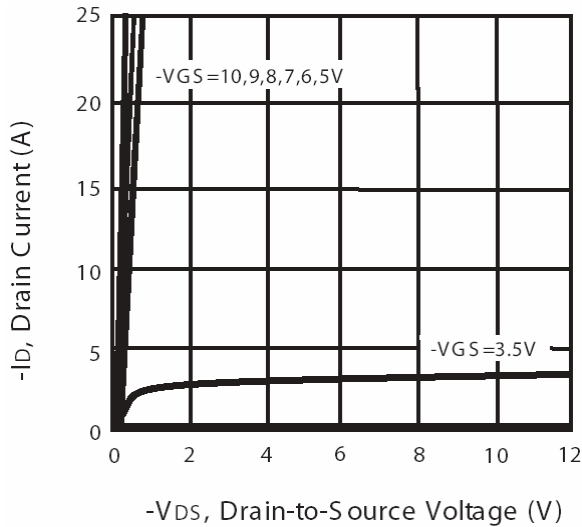

Fig 1. Typical Output Characteristics

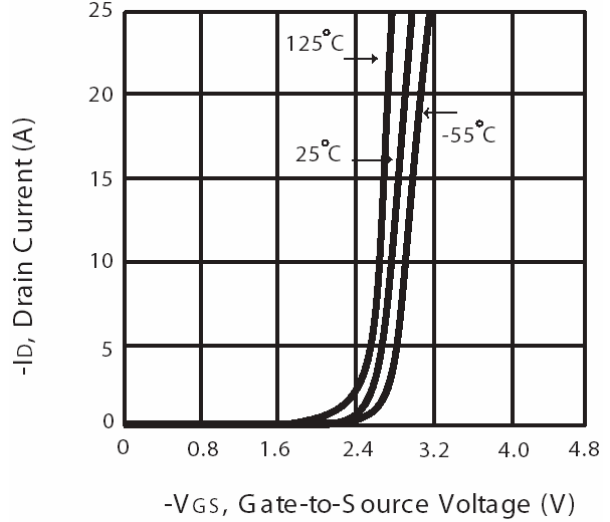

Fig 2. Transfer Characteristics

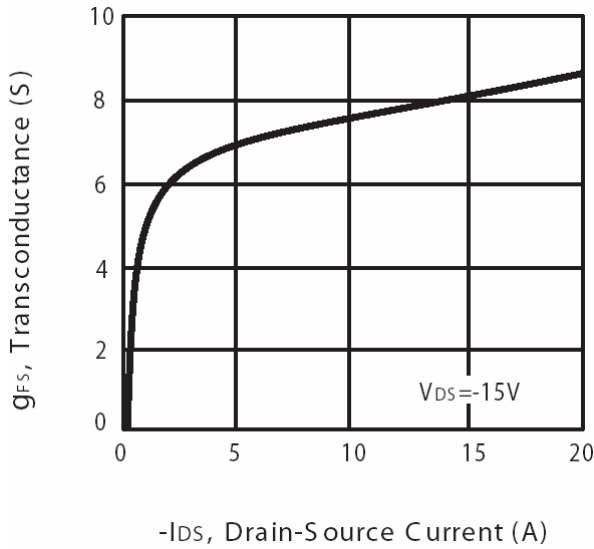

Fig 3. Transconductance v.s. Drain Current

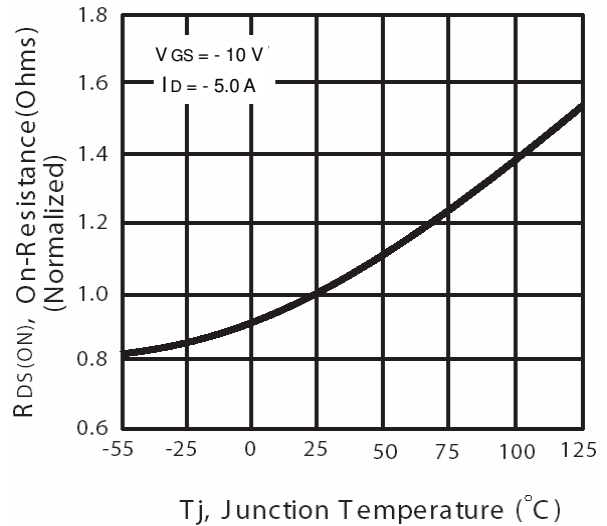

Fig 4. On-Resistance v.s. Junction Temperature

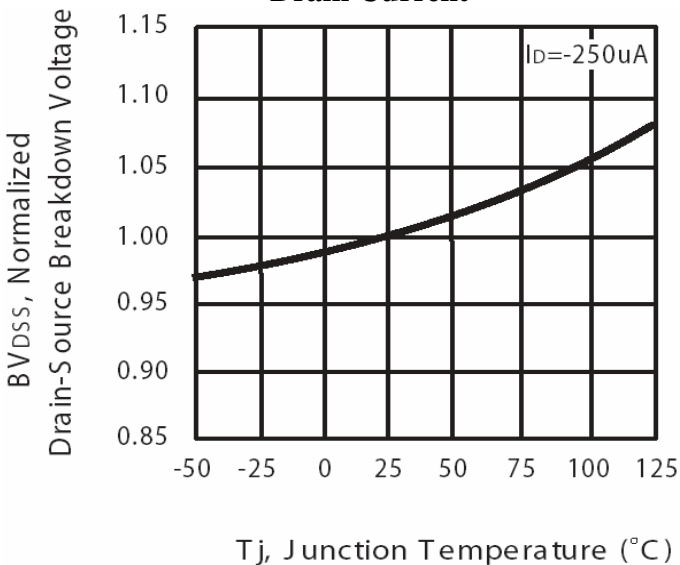

Fig 5. Breakdown Voltage v.s. Junction Temperature

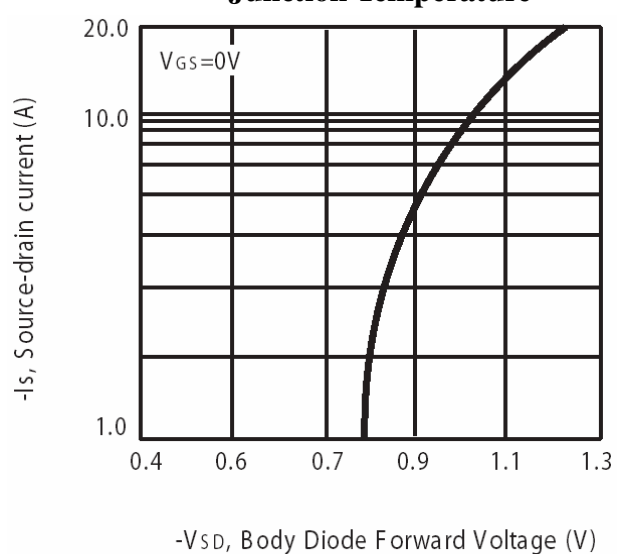

Fig 6. Body Diode Forward Voltage v.s. Source Current

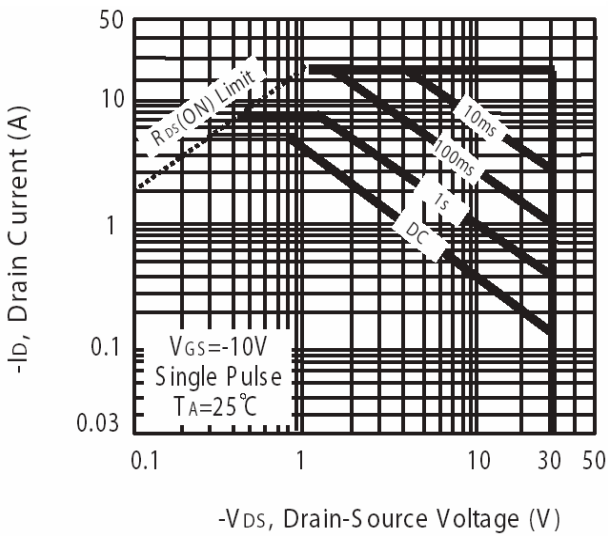

Fig 7. Maximum Safe Operating Area

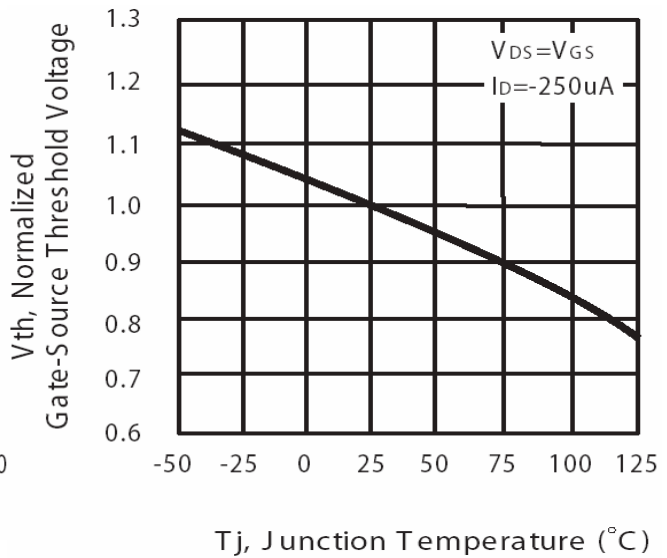

Fig 8. Gate Threshold Voltage v.s. Junction Temperature

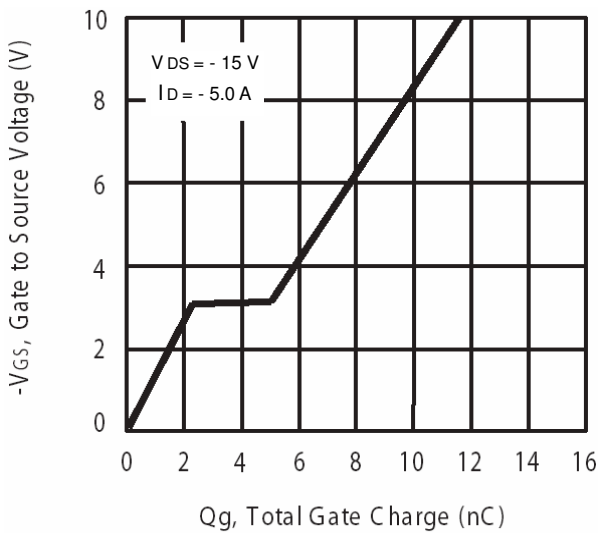

Fig 9. Gate Charge Characteristics

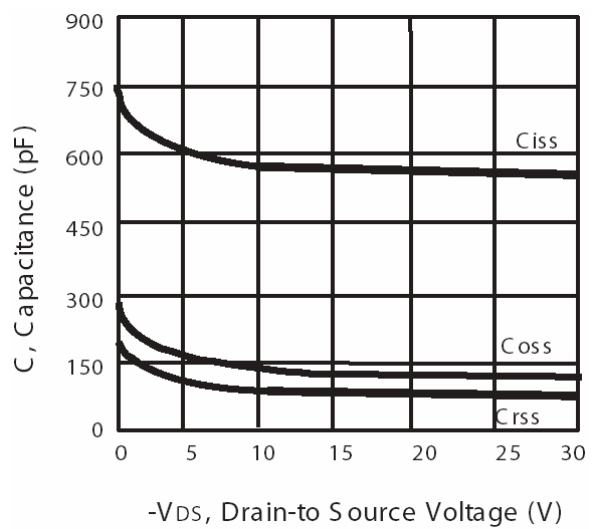

Fig 10. Typical Capacitance Characteristics

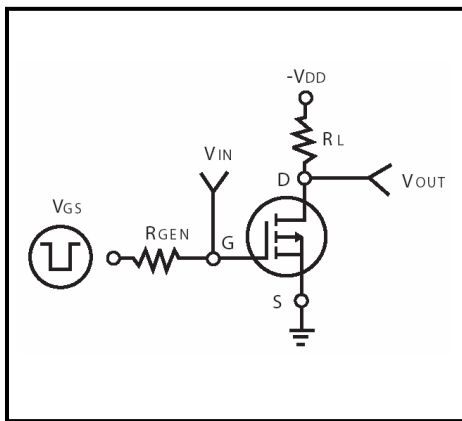

Fig 11. Switching Time Circuit

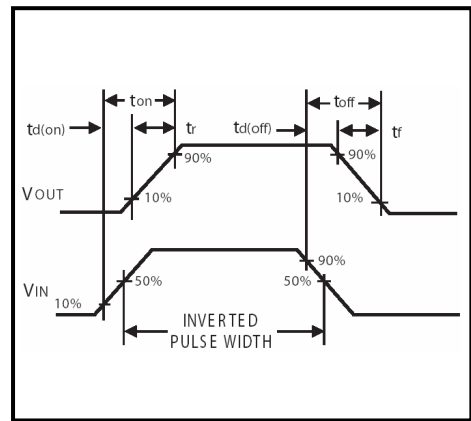

Fig 12. Switching Time Waveform

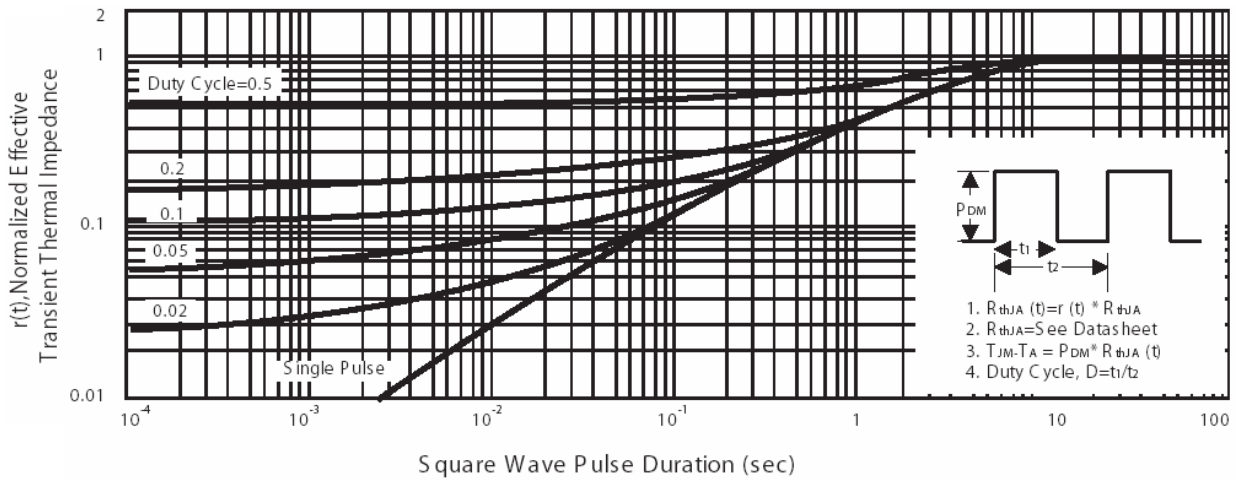

Fig 13. Normalized Thermal Transient Impedance Curve

Important Notice:

- All rights are reserved. Reproduction in whole or in part is prohibited without the prior written approval of GTM.
- GTM reserves the right to make changes to its products without notice.
- GTM semiconductor products are not warranted to be suitable for use in life-support Applications, or systems.
- GTM assumes no liability for any consequence of customer product design, infringement of patents, or application assistance.

Head Office And Factory:

- **Taiwan:** No. 17-1 Tatung Rd. Fu Kou Hsin-Chu Industrial Park, Hsin-Chu, Taiwan, R. O. C.
- TEL : 886-3-597-7061 FAX : 886-3-597-9220, 597-0785
- **China:** (201203) No.255, Jang-Jiang Tsai-Lueng RD. , Pu-Dung-Hsin District, Shang-Hai City, China
- TEL : 86-21-5895-7671 ~ 4 FAX : 86-21-38950165