

HA1127, HA1127P, HA1127FP

5 Transistor Arrays

HITACHI

Pin Arrangement

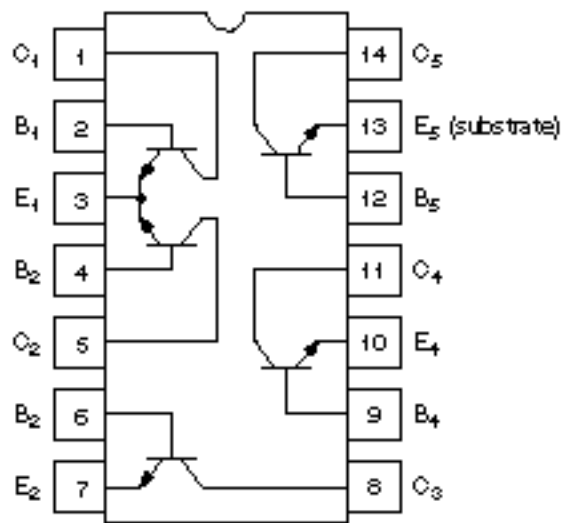

(Top view)

Note: Use pin 13 as the lowest potential for this IC.

HITACHI

HA1127, HA1127P, HA1127FP

Absolute Maximum Ratings (Ta = 25°C)

Item	Symbol	HA1127	Unit
Collector base voltage	V_{CBO}	20	V
Collector substrate voltage	V_{CIO}	20	V
Collector emitter voltage	V_{CEO}	15	V
Emitter-base voltage	V_{EBO}	5	V
Collector current	I_C	50	mA
Allowable collector power	P_C^{*1}	300	mW
Allowable collector power	P_C	750^{*2} 625^{*3}	mW
Operating temperature	T_{opr}	-55 to +125	°C
Storage temperature	T_{stg}	-55 to +125	°C

Notes: 1. Allowable value per individual transistor. This is the allowable value up to Ta = 25°C. Derate at 3 mW/°C above that temperature.

2. Allowable value for the whole package.

This is the allowable value up to Ta = 35°C for the HA1127P. Derate at 8.3 mW/°C above that temperature.

3. See page 51.

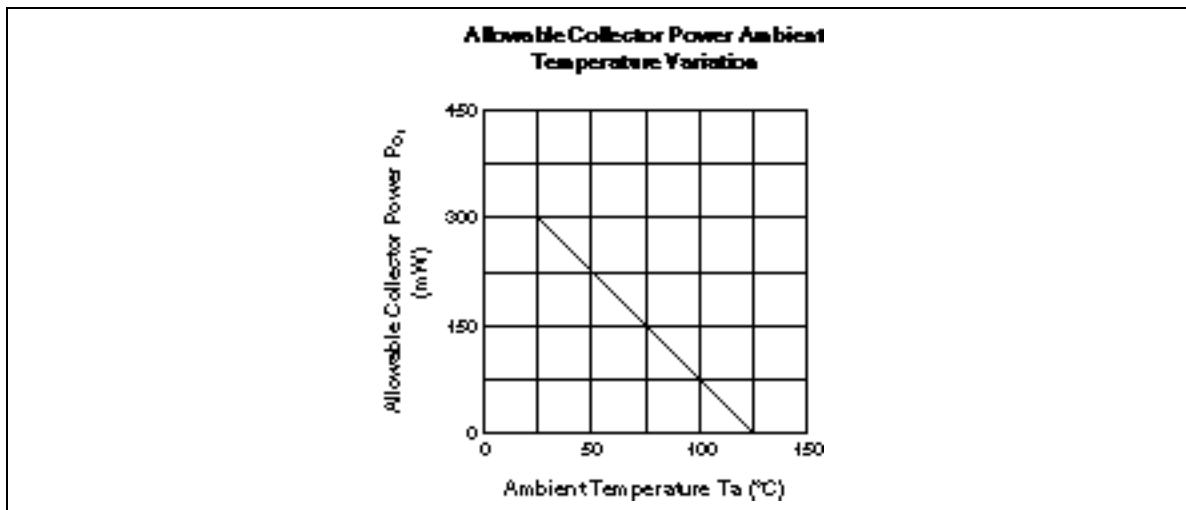

HITACHI

HA1127, HA1127P, HA1127FP

Electrical Characteristics (Ta = 25°C)

Item	Symbol	Min	Typ	Max	Unit	Test Condition	
Collector-base breakdown voltage	$V_{(BR)CBO}$	20	—	—	V	$I_C = 10 \mu A, I_E = 0$	
Collector-emitter breakdown voltage	$V_{(BR)CEO}$	15	—	—	V	$I_C = 1 \text{ mA}, R_{BE} =$	
Collector-substrate breakdown voltage	$V_{(BR)C1O}$	20	—	—	V	$I_C = 10 \mu A, I_E = 0, I_B = 0$	
Emitter-base breakdown voltage	$V_{(BR)EBO}$	5	—	—	V	$I_E = 10 \mu A, I_C = 0$	
Collector cutoff current	I_{CBO}	—	0.002	40	nA	$V_{CB} = 10 \text{ V}, I_E = 0$	
	I_{CEO}	—	—	0.5	μA	$V_{CE} = 10 \text{ V}, R_{BE} =$	
Collector-emitter saturation voltage	$V_{CE(sat)}$	—	0.17	—	V	$I_C = 10 \text{ mA}, I_B = 1 \text{ mA}$	
Base-emitter voltage	V_{BE}	—	0.72	—	V	$V_{CE} = 3 \text{ V}$	$I_C = 1 \text{ mA}$
		—	0.80	—	V		$I_C = 10 \text{ mA}$
DC current amplification ratio	h_{FE}	40	140	—		$V_{EE} = 3 \text{ V}$	$I_C = 1 \text{ mA}$
		—	120	—			$I_C = 10 \text{ mA}$
Gain-bandwidth product	f_T	—	460	—	MHz	$V_{CE} = 3 \text{ V}, I_C = 3 \text{ mA}$	
Collector output capacitance	C_{ob}	—	1.7	—	pF	$V_{CB} = 3 \text{ V}, I_E = 0, f = 1 \text{ MHz}$	
Emitter input capacitance	C_{in}	—	2.0	—	pF	$V_{CB} = 3 \text{ V}, I_E = 0, f = 1 \text{ MHz}$	
Switching time	t_{on}	—	35	—	ns	$V_{CC} = 10 \text{ V}, I_C = 10 \text{ mA}, I_{B1} = -10 \text{ mA}, I_{B2} = 10 \text{ mA}$	
	t_{off}	—	130	—	ns		
	t_{stg}	—	75	—	ns		

HA1127, HA1127P, HA1127FP

Switching Time Test Circuit

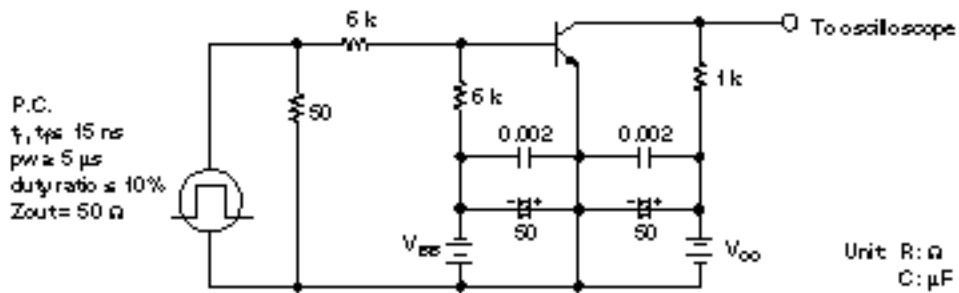

Response Waveform

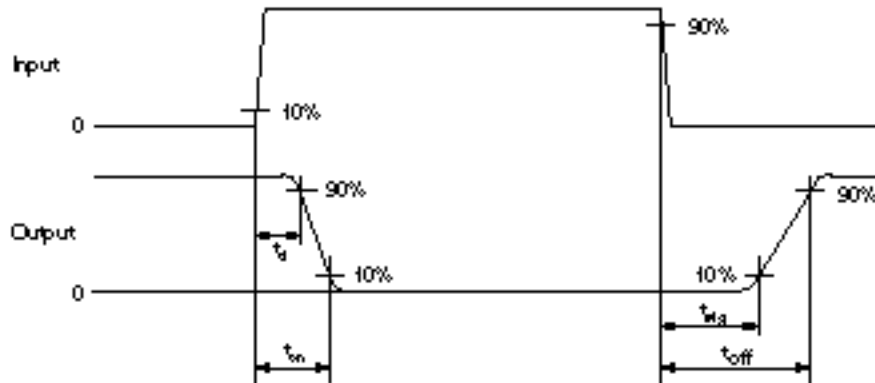

Operating Conditions

Symbol	I_b	I_{b1}	I_{b2}	V_{CC}	V_{EE}	V_{IN}
Unit	mA	mA	mA	V	V	V
Bias	10	+1.0	-1.0	10.2	-6.0	+13.0

HITACHI

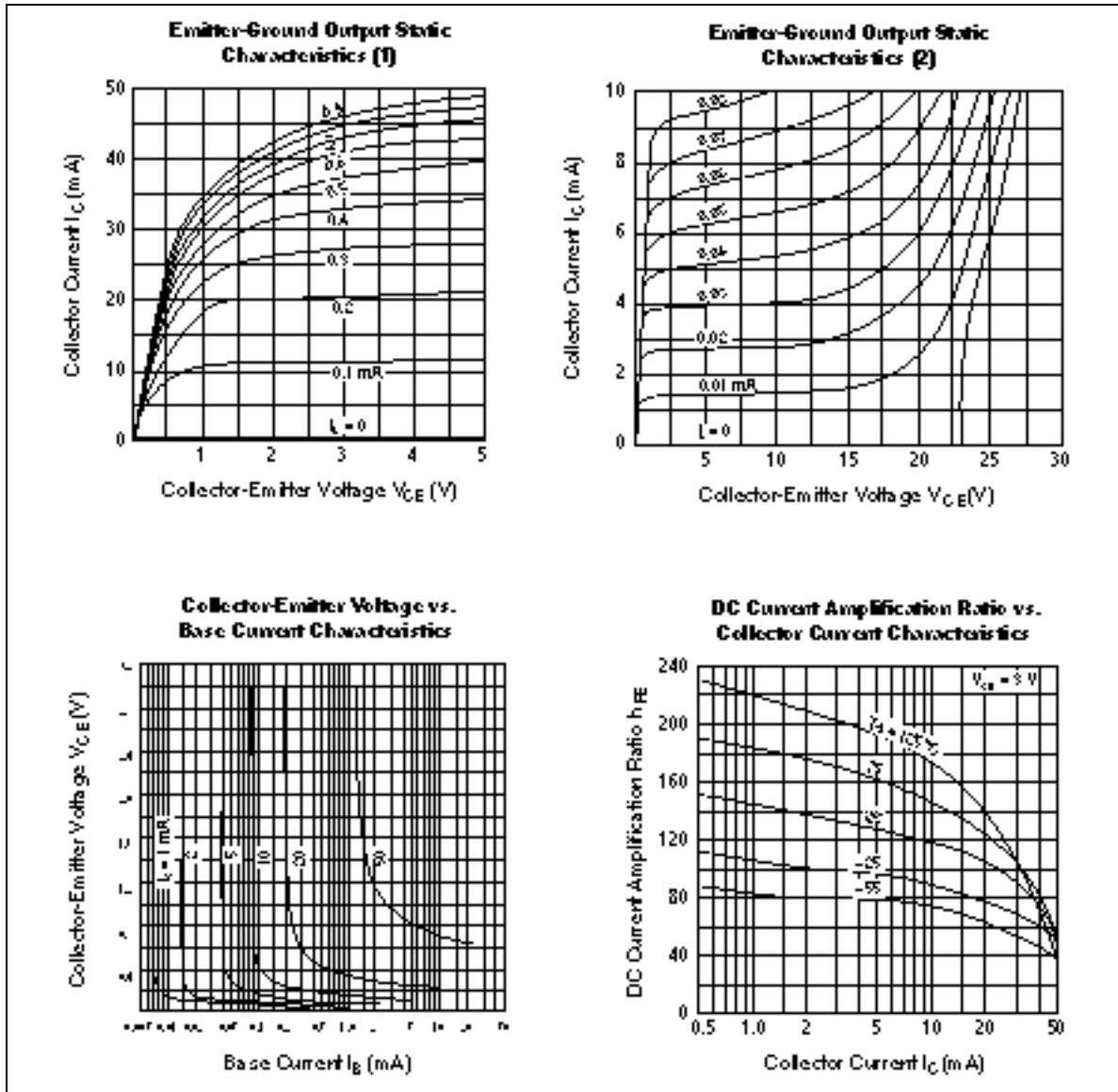

HA1127, HA1127P, HA1127FP

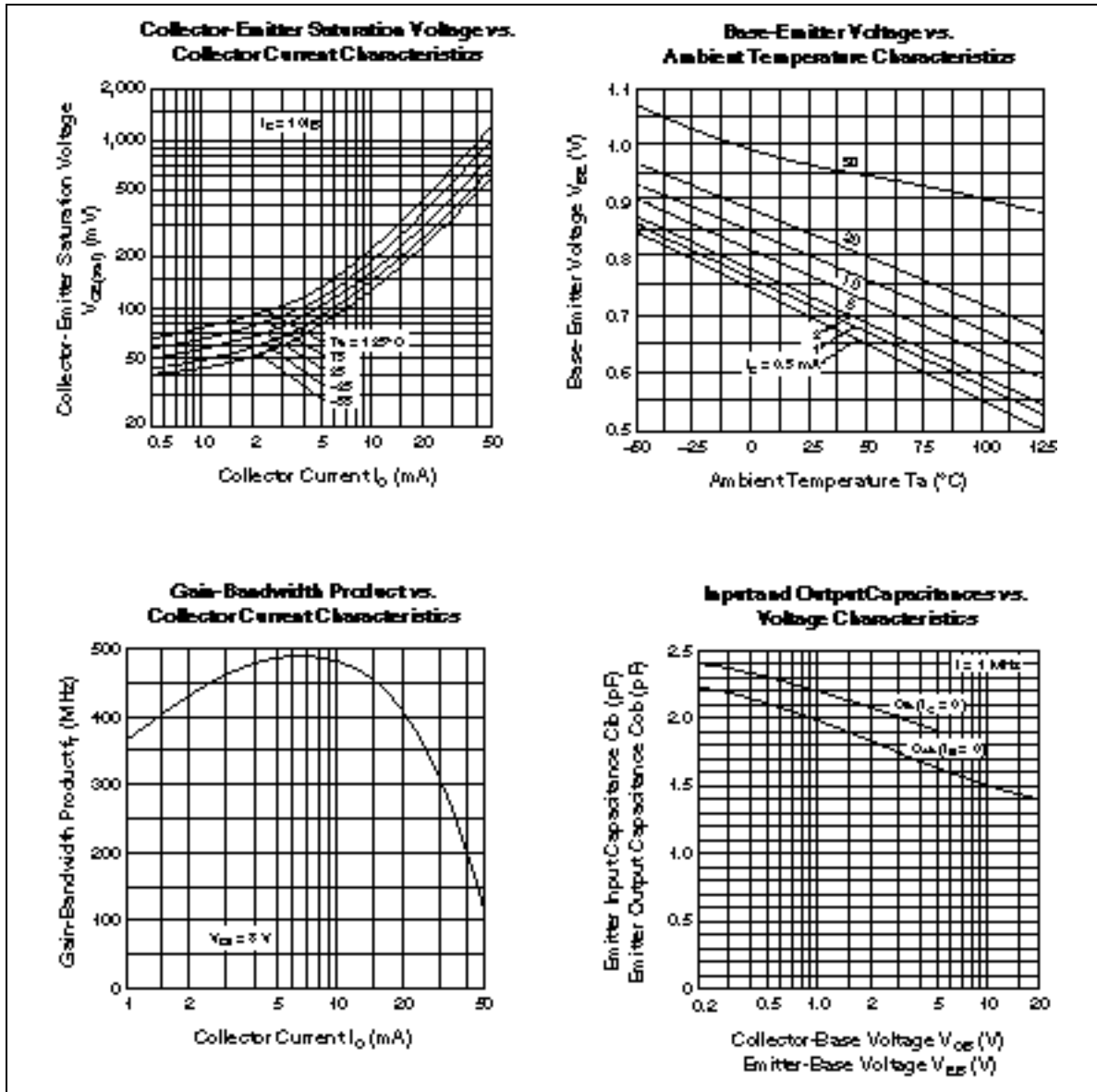

HITACHI

HA1127, HA1127P, HA1127FP

