

# Current Transducer HAL 50..600-S

For the electronic measurement of DC, AC and pulsed currents, with a galvanic isolation between the primary (high power) circuit and the secondary (electronic) circuit.

$$I_{PN} = 50 \text{ A}$$

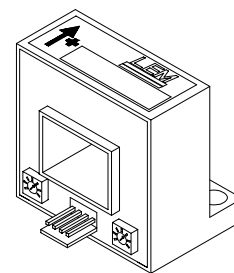

## Electrical data

Primary nominal r.m.s. current $I_{PN}$ (A)	Primary current measuring range $I_P$ (A)	Type
50	± 150	HAL 50-S
100	± 300	HAL 100-S
200	± 600	HAL 200-S
300	± 900	HAL 300-S
400	± 1000	HAL 400-S
500	± 1000	HAL 500-S
600	± 1000	HAL 600-S

$\hat{I}_P$	Overload capacity (Ampere Turns)	30000	A
$V_{OUT}$	Analogue output voltage @ ± $I_{PN}$	± 4	V
$R_L$	Load resistance $T_A = 0 \dots +70^\circ\text{C}$ $T_A = -25 \dots +85^\circ\text{C}$	> 1	k $\Omega$
		> 3	k $\Omega$
$V_C$	Supply voltage (± 5%)	± 15	V
$I_C$	Current consumption (max)	25	mA
$V_b$	Rms rated voltage <sup>1)</sup>	500	V
$V_d$	Rms voltage for AC isolation test, 50 Hz, 1 mn	3	kV
$R_{is}$	Isolation resistance @ 500 $V_{DC}$	> 500	M $\Omega$

## Accuracy - Dynamic performance data

<b>X</b>	Accuracy <sup>2)</sup> @ $I_{PN}, T_A = 25^\circ\text{C}, @ \pm 15 \text{ V}$	± 1	%
<b>e<sub>L</sub></b>	Linearity <sup>2)</sup>	± 0.5	%
		Max	
<b>V<sub>OE</sub></b>	Electrical offset voltage @ $I_P = 0, T_A = 25^\circ\text{C}$	± 10	mV
<b>V<sub>OM</sub></b>	Residual offset voltage @ $I_P = 0$ after an overload of $3 \times I_{PN}$	± 10	mV
<b>V<sub>OT</sub></b>	Thermal drift of offset voltage $T_A = -25 \dots +85^\circ\text{C}$	± 2	mV/°K
<b>Tce<sub>G</sub></b>	Thermal drift of gain $T_A = -25 \dots +85^\circ\text{C}$	± 0.05	%/°K
<b>t<sub>r</sub></b>	Response time @ 90 % of $I_P$	< 3	μs
<b>di/dt</b>	di/dt accurately followed	> 50	A/μs
<b>f</b>	Frequency bandwidth (-3 dB) <sup>3)</sup>	DC .. 50	kHz

## General data

<b>T<sub>A</sub></b>	Ambient operating temperature	-25 .. +85	°C
<b>T<sub>S</sub></b>	Ambient storage temperature	-25 .. +85	°C
<b>m</b>	Mass	75	g
	Standards	EN50178 (1994)	
	Safety	EN50082-2 (1992)	
	EMC	EN50081-1 (1992)	
	Deviation in output when tested to EN 61000-4-6	< 10	% of $I_{PN}$
	Deviation in output when tested to EN 61000-4-4	< 10	% of $I_{PN}$

## Features

- Open loop transducer using Hall Effect
- Panel mounting - Horizontal or Vertical
- Insulated plastic case to UL 94-V0.

## Advantages

- Very good linearity
- Very good accuracy
- Low temperature drift
- Wide frequency bandwidth
- Very low insertion losses
- High immunity to external interference
- Current overload capability
- Low power consumption
- Wide dynamic range, 50 to 600 A in one package.

## Applications

- AC variable speed drives and servo motor drives
- Static converters for DC motor drives
- Battery supplied applications
- Uninterruptable Power Supplies (UPS)
- Switched Mode Power Supplies (SMPS)
- Power supplies for welding applications.

Notes : <sup>1)</sup> Overvoltage Category III, Pollution Degree 2

<sup>2)</sup> Excludes the electrical offset

<sup>3)</sup> Refer to derating curves in the technical file to avoid excessive core

heating at high frequency

## Dimensions HAL 50..600-S (in mm)

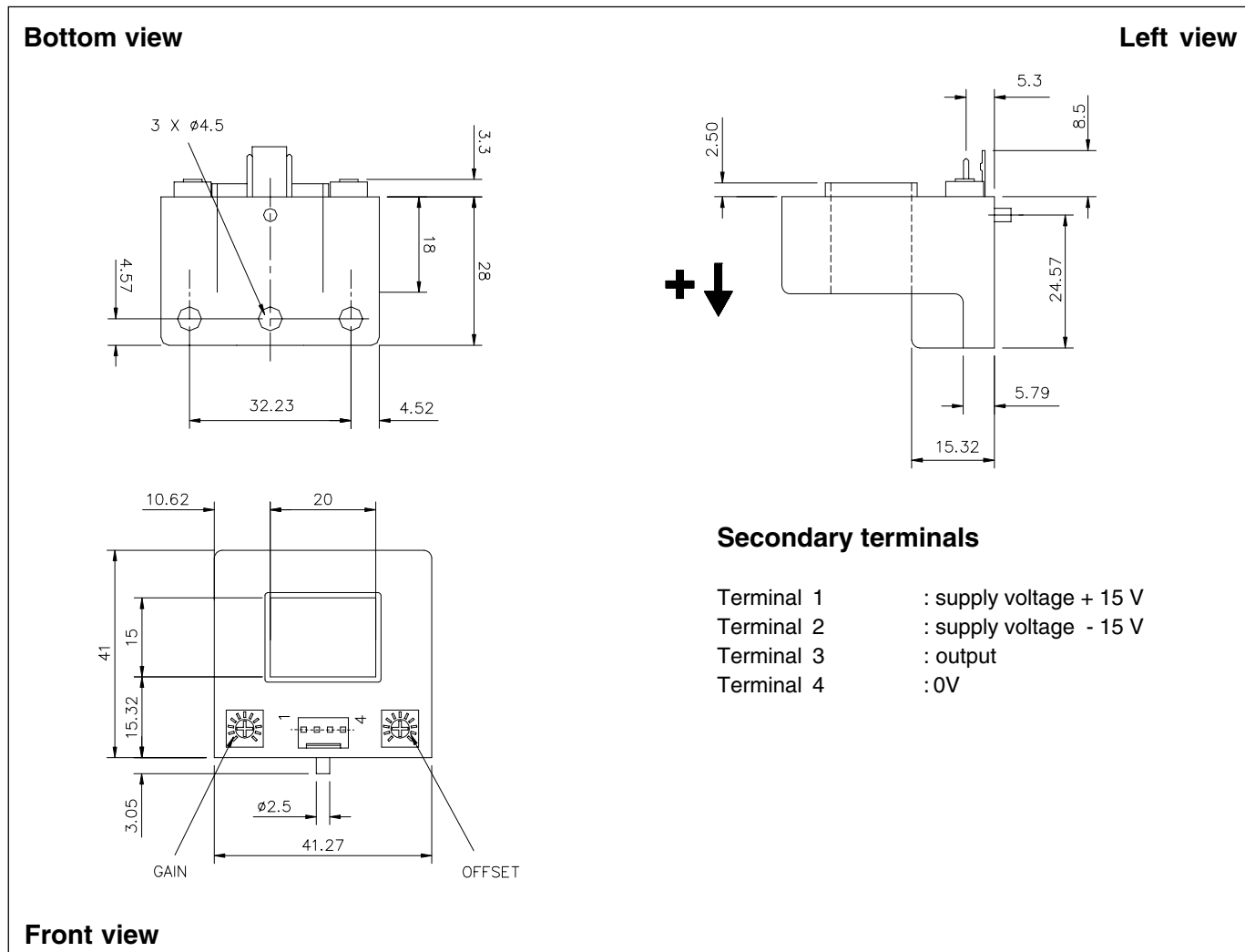

### Mechanical characteristics

- General tolerance  $\pm 0.5$  mm
- Primary through-hole 20 mm x 15 mm
- Connection of secondary Molex 5045-04-A

### Remarks

- $V_{OUT}$  is positive when  $I_p$  flows in the direction of the arrow.
- Temperature of the primary conductor should not exceed 90°C.
- This is a standard model. For different versions (supply voltages, secondary connections, unidirectional measurements, operating temperatures, etc.) please contact us.