

Automotive Single Supply, SPDT Analog Switch

ISL76123

The Intersil ISL76123 device is a small precision, bidirectional, single-pole/double throw (SPDT) analog switch, designed to operate from a single +2.7V to +12V supply. The device is supplied in a 6 Ld SOT-23 package. Targeted applications include automotive battery powered systems that can benefit from the device's low power consumption (5μW), low leakage currents (3nA max), and fast switching speeds ($t_{ON} = 28\text{ns}$, $t_{OFF} = 20\text{ns}$). This device will often find use in infotainment systems to “mux-in” additional functions to GPIO pins on SOCs. The device ensures the switching function is always break-before-make to help eliminate transient signal problems. Its small package size alleviates board space limitations. The part has been qualified for use in automotive applications across an operating temperature range of -40°C to +105°C.

TABLE 1. FEATURES AT A GLANCE

	ISL76123
SW 1/SW 2	SPDT or 2x1 MUX
3.3V r_{ON}	42Ω
3.3V t_{ON}/t_{OFF}	40ns/20ns
5V r_{ON}	23Ω
5V t_{ON}/t_{OFF}	28ns/20ns
12V r_{ON}	15Ω
12V t_{ON}/t_{OFF}	25ns/17ns
Package	6 Ld SOT-23

Features

- Fully specified at 12V, 5V, and 3.3V supplies for 10% tolerances
- r_{ON} -resistance (r_{ON}) 23Ω
- r_{ON} matching between channels <1Ω
- Low charge injection 5pC (Max)
- Single supply operation +2.7V to +12V
- Low power consumption (P_D) <5μW
- Low leakage current 10nA
- Fast switching action
 - t_{ON} 28ns
 - t_{OFF} 20ns
- Guaranteed break-before-make switching
- Minimum 2000V ESD protection
- TTL, CMOS compatible
- Available in 6 Ld SOT-23 package
- Pb-free (RoHS compliant)
- AEC-Q100 qualified

Applications

- Audio and video switching
- General signal “mux-in” (where GPIO lines may be constrained)
- Various building block control applications
 - Filters
 - Signal conditioning
 - Integration reset circuits

ISL76123

Pin Configuration (Note)

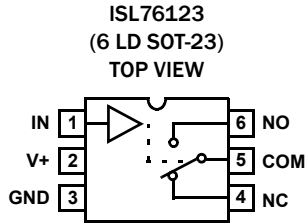

NOTE: Switch Shown for Logic "0" Input.

Pin Descriptions

PIN NAME	PIN NUMBER	FUNCTION
V+	2	System Power Supply Input (+2.7V to +12V)
GND	3	Ground Connection
IN	1	Digital Control Input
COM	5	Analog Switch Common Pin
NO	6	Analog Switch Normally Open Pin
NC	4	Analog Switch Normally Closed Pin

Truth Table

LOGIC	ISL76123	
	PIN NC	PIN NO
0	ON	OFF
1	OFF	ON

NOTE: Logic "0" $\leq 0.8V$. Logic "1" $\geq 2.4V$.

Ordering Information

PART NUMBER (Notes 1, 2, 3)	PART MARKING (Note 4)	TEMP. RANGE (°C)	PACKAGE (Pb-free)	PKG. DWG. #
ISL76123AHZ-T	123A	-40 to +105	6 Ld SOT-23 Tape and Reel	P6.064

NOTES:

- Please refer to [TB347](#) for details on reel specifications.
- These Intersil Pb-free plastic packaged products employ special Pb-free material sets, molding compounds/die attach materials, and 100% matte tin plate plus anneal (e3 termination finish, which is RoHS compliant and compatible with both SnPb and Pb-free soldering operations). Intersil Pb-free products are MSL classified at Pb-free peak reflow temperatures that meet or exceed the Pb-free requirements of IPC/JEDEC J STD-020.
- For Moisture Sensitivity Level (MSL), please see device information page for [ISL76123](#). For more information on MSL please see tech brief [TB363](#).
- The part marking is located on the bottom of the part.

ISL76123

Absolute Maximum Ratings

V+ to GND	-0.3 to 15V
Input Voltages	
IN (Note 5)	-0.3 to ((V+) + 0.3V)
NO, NC (Note 5)	-0.3 to ((V+) + 0.3V)
Output Voltages	
COM (Note 5)	-0.3 to ((V+) + 0.3V)
Continuous Current (Any Terminal)	30mA
Peak Current NO, NC, or COM	
(Pulsed 1ms, 10% Duty Cycle, Max)	40mA
ESD Rating	
Human Body Model (Tested per JESD22-A114E)	2kV
Machine Model (Tested per JESD22-A115-A)	100V
Charged Device Model (Tested per AEC-Q100-11)	1kV
Latch-up (Tested per JESD-78B; Class 2, Level A)	100mA

Thermal Information

Thermal Resistance (Typical)	θ_{JA} (°C/W)	θ_{JC} (°C/W)
6 Ld SOT-23 Package (Notes 6, 7)	175	95
Maximum Junction Temperature (Plastic Package)	+150°C	
Maximum Storage Temperature Range	-65°C to +150°C	

Operating Conditions

Temperature Range	-40°C to +105°C
-------------------	-----------------

CAUTION: Do not operate at or near the maximum ratings listed for extended periods of time. Exposure to such conditions may adversely impact product reliability and result in failures not covered by warranty.

NOTES:

- Signals on NC, NO, COM, or IN exceeding V+ or GND are clamped by internal diodes. Limit forward diode current to maximum current ratings.
- θ_{JA} is measured with the component mounted on a high effective thermal conductivity test board in free air. See Tech Brief [TB379](#) for details.
- For θ_{JC} , the "case temp" location is taken at the package top center.

Electrical Specifications - 5V Supply Test Conditions: V+ = +4.5V to +5.5V, GND = 0V, V_{INH} = 2.4V, V_{INL} = 0.8V (Note 8), unless otherwise specified. **Boldface limits apply across the operating temperature range, -40°C to +105°C.**

PARAMETER	TEST CONDITIONS	TEMP (°C)	MIN (Notes 9, 10)	TYP	MAX (Notes 9, 10)	UNITS
ANALOG SWITCH CHARACTERISTICS						
Analog Signal Range, V_{ANALOG}		Full	0	-	V+	V
ON-Resistance, r_{ON}	V+ = 4.5V, I_{COM} = 1.0mA, V_{NO} or V_{NC} = 3.5V (Figure 5)	+25	-	23	34	Ω
		Full	-	25	40	Ω
r_{ON} Matching Between Channels, Δr_{ON}	V+ = 5V, I_{COM} = 1.0mA, V_{NO} or V_{NC} = 3.5V	+25	-	0.8	2	Ω
		Full	-	1	4	Ω
r_{ON} Flatness, $R_{FLAT(ON)}$	V+ = 5V, I_{COM} = 1.0mA, V_{NO} or V_{NC} = 1V, 2V, 3V (Note 11)	Full	-	7	8	Ω
NO or NC OFF Leakage Current, $I_{NO(OFF)}$ or $I_{NC(OFF)}$	V+ = 5.5V, V_{COM} = 1V, 4.5V, V_{NO} or V_{NC} = 4.5V, 1V	+25	-3	0.01	3	nA
		Full	-5	-	5	nA
COM OFF Leakage Current, $I_{COM(OFF)}$	V+ = 5.5V, V_{COM} = 4.5V, 1V, V_{NO} or V_{NC} = 1V, 4.5V	+25	-3	-	3	nA
		Full	-5	-	5	nA
COM ON Leakage Current, $I_{COM(ON)}$	V+ = 5.5V, V_{COM} = 1V, 4.5V, or V_{NO} or V_{NC} = 1V, 4.5V or Floating	+25	-5	-	5	nA
		Full	-10	-	10	nA
DYNAMIC CHARACTERISTICS						
Turn-ON Time, t_{ON}	V_{NO} or V_{NC} = 3V, R_L = 1k Ω , C_L = 35pF, V_{IN} = 0V to 3V (see Figure 1)	+25	-	28	-	ns
		Full	-	40	-	ns
Turn-OFF Time, t_{OFF}	V_{NO} or V_{NC} = 3V, R_L = 1k Ω , C_L = 35pF, V_{IN} = 0V to 3V (see Figure 1)	+25	-	20	-	ns
		Full	-	30	-	ns
Break-Before-Make Time Delay, t_D	R_L = 300 Ω , C_L = 35pF, V_{NO} = V_{NC} = 3V, V_{IN} = 0V to 3V (see Figure 3)	Full	-	10	-	ns
Charge Injection, Q	C_L = 1.0nF, V_G = 0V, R_G = 0 Ω (see Figure 2)	+25	-	3	-	pC
OFF Isolation	R_L = 50 Ω , C_L = 5pF, f = 1MHz (see Figure 4)	+25	-	76	-	dB
Power Supply Rejection Ratio	R_L = 50 Ω , C_L = 5pF, f = 1MHz	+25	-	60	-	dB
NO or NC OFF Capacitance, C_{OFF}	f = 1MHz, V_{NO} or V_{NC} = V_{COM} = 0V (see Figure 7)	+25	-	8	-	pF

ISL76123

Electrical Specifications - 5V Supply Test Conditions: $V^+ = +4.5V$ to $+5.5V$, $GND = 0V$, $V_{INH} = 2.4V$, $V_{INL} = 0.8V$ (Note 8), unless otherwise specified. **Boldface limits apply across the operating temperature range, $-40^\circ C$ to $+105^\circ C$.** (Continued)

PARAMETER	TEST CONDITIONS	TEMP ($^\circ C$)	MIN (Notes 9, 10)	TYP	MAX (Notes 9, 10)	UNITS
COM OFF Capacitance, $C_{COM(OFF)}$	$f = 1MHz$, V_{NO} or $V_{NC} = V_{COM} = 0V$ (see Figure 7)	+25	-	8	-	pF
COM ON Capacitance, $C_{COM(ON)}$	$f = 1MHz$, V_{NO} or $V_{NC} = V_{COM} = 0V$ (see Figure 7)	+25	-	28	-	pF
POWER SUPPLY CHARACTERISTICS						
Power Supply Range		Full	2.7	-	12	V
Positive Supply Current, I^+	$V^+ = 5.5V$, $V_{IN} = 0V$ or V^+ , all channels on or off	Full	-1	0.0001	1	μA
DIGITAL INPUT CHARACTERISTICS						
Input Voltage Low, V_{INL}		Full	-	-	0.8	V
Input Voltage High, V_{INH}		Full	2.4	-	-	V
Input Current, I_{INH} , I_{INL}	$V^+ = 5.5V$, $V_{IN} = 0V$ or V^+	Full	-1	-	1	μA

Electrical Specifications - 3.3V Supply Test Conditions: $V^+ = +3.0V$ to $+3.6V$, $GND = 0V$, $V_{INH} = 2.4V$, $V_{INL} = 0.8V$ (Note 8), unless otherwise specified. **Boldface limits apply across the operating temperature range, $-40^\circ C$ to $+105^\circ C$.**

PARAMETER	TEST CONDITIONS	TEMP ($^\circ C$)	MIN (Notes 9, 10)	TYP	MAX (Notes 9, 10)	UNITS
ANALOG SWITCH CHARACTERISTICS						
Analog Signal Range, V_{ANALOG}		Full	0	-	V^+	V
ON-Resistance, r_{ON}	$V^+ = 3V$, $I_{COM} = 1.0mA$, V_{NO} or $V_{NC} = 1.5V$	+25	-	42	60	Ω
		Full	-	45	70	Ω
r_{ON} Matching Between Channels, Δr_{ON}	$V^+ = 3.3V$, $I_{COM} = 1.0mA$, V_{NO} or $V_{NC} = 1.5V$	+25	-	0.8	2	Ω
		Full	-	1	4	Ω
r_{ON} Flatness, $R_{FLAT(ON)}$	$V^+ = 3.3V$, $I_{COM} = 1.0mA$, V_{NO} or $V_{NC} = 0.5V, 1V, 1.5V$	+25	-	6	10	Ω
		Full	-	7	12	Ω
NO or NC OFF Leakage Current, $I_{NO(OFF)}$ or $I_{NC(OFF)}$	$V^+ = 3.6V$, $V_{COM} = 1V, 3V$, V_{NO} or $V_{NC} = 3V, 1V$	+25	-3	0.01	3	nA
		Full	-5	-	5	nA
COM OFF Leakage Current, $I_{COM(OFF)}$	$V^+ = 3.6V$, $V_{COM} = 3V, 1V$, V_{NO} or $V_{NC} = 1V, 3V$	+25	-3	0.01	3	nA
		Full	-5	-	5	nA
COM ON Leakage Current, $I_{COM(ON)}$	$V^+ = 3.6V$, $V_{COM} = 1V, 3V$, or V_{NO} or $V_{NC} = 1V, 3V$ or floating	+25	-5	-	5	nA
		Full	-10	-	10	nA
DYNAMIC CHARACTERISTICS						
Turn-ON Time, t_{ON}	V_{NO} or $V_{NC} = 1.5V$, $R_L = 1k\Omega$, $C_L = 35pF$, $V_{IN} = 0V$ to $3V$	+25	-	40	-	ns
		Full	-	60	-	ns
Turn-OFF Time, t_{OFF}	V_{NO} or $V_{NC} = 1.5V$, $R_L = 1k\Omega$, $C_L = 35pF$, $V_{IN} = 0V$ to $3V$	+25	-	20	-	ns
		Full	-	30	-	ns
Break-Before-Make Time Delay, t_D	$R_L = 300\Omega$, $C_L = 35pF$, V_{NO} or $V_{NC} = 1.5V$, $V_{IN} = 0V$ to $3V$	Full	-	20	-	ns
Charge Injection, Q	$C_L = 1.0nF$, $V_G = 0V$, $R_G = 0\Omega$	+25	-	1	-	pC
OFF Isolation	$R_L = 50\Omega$, $C_L = 5pF$, $f = 1MHz$	+25	-	76	-	dB
Power Supply Rejection Ratio	$R_L = 50\Omega$, $C_L = 5pF$, $f = 1MHz$	+25	-	56	-	dB
NO or NC OFF Capacitance, C_{OFF}	$f = 1MHz$, V_{NO} or $V_{NC} = V_{COM} = 0V$	+25	-	8	-	pF
COM OFF Capacitance, $C_{COM(OFF)}$	$f = 1MHz$, V_{NO} or $V_{NC} = V_{COM} = 0V$	+25	-	8	-	pF
COM ON Capacitance, $C_{COM(ON)}$	$f = 1MHz$, V_{NO} or $V_{NC} = V_{COM} = 0V$ (see Figure 7)	+25	-	28	-	pF

ISL76123

Electrical Specifications - 3.3V Supply Test Conditions: $V+ = +3.0V$ to $+3.6V$, $GND = 0V$, $V_{INH} = 2.4V$, $V_{INL} = 0.8V$ (Note 8), unless otherwise specified. **Boldface limits apply across the operating temperature range, $-40^{\circ}C$ to $+105^{\circ}C$.** (Continued)

PARAMETER	TEST CONDITIONS	TEMP (°C)	MIN (Notes 9, 10)	TYP	MAX (Notes 9, 10)	UNITS
POWER SUPPLY CHARACTERISTICS						
Positive Supply Current, $I+$	$V+ = 3.6V$, $V_{IN} = 0V$ or $V+$, all channels on or off	Full	-1	-	1	μA
DIGITAL INPUT CHARACTERISTICS						
Input Voltage Low, V_{INL}		Full	-	-	0.8	V
Input Voltage High, V_{INH}		Full	2.4	-	-	V
Input Current, I_{INH} , I_{INL}	$V+ = 3.6V$, $V_{IN} = 0V$ or $V+$	Full	-1	-	1	μA

Electrical Specifications - 12V Supply Test Conditions: $V+ = +10.8V$ to $+13V$, $GND = 0V$, $V_{INH} = 4V$, $V_{INL} = 0.8V$ (Note 8), unless otherwise specified. **Boldface limits apply across the operating temperature range, $-40^{\circ}C$ to $+105^{\circ}C$.**

PARAMETER	TEST CONDITIONS	TEMP (°C)	MIN (Notes 9, 10)	TYP	MAX (Notes 9, 10)	UNITS
ANALOG SWITCH CHARACTERISTICS						
Analog Signal Range, V_{ANALOG}		Full	0	-	V+	V
ON-Resistance, r_{ON}	$V+ = 10.8V$, $I_{COM} = 1.0mA$, V_{NO} or $V_{NC} = 10V$	+25	-	15	23	Ω
		Full	-	16	25	Ω
r_{ON} Matching Between Channels, Δr_{ON}	$V+ = 12V$, $I_{COM} = 1.0mA$, V_{NO} or $V_{NC} = 10V$	+25	-	0.8	2	Ω
		Full	-	1	4	Ω
r_{ON} Flatness, $R_{FLAT(ON)}$	$V+ = 12V$, $I_{COM} = 1.0mA$, V_{NO} or $V_{NC} = 3V, 6V, 9V$ (Note 11)	+25	-	1	4	Ω
		Full	-	-	6	Ω
NO or NC OFF Leakage Current, $I_{NO(OFF)}$ or $I_{NC(OFF)}$	$V+ = 13V$, $V_{COM} = 1V, 12V$, V_{NO} or $V_{NC} = 12V, 1V$	+25	-3	0.01	3	nA
		Full	-5	-	5	nA
COM OFF Leakage Current, $I_{COM(OFF)}$	$V+ = 13V$, $V_{COM} = 12V, 1V$, V_{NO} or $V_{NC} = 1V, 12V$	+25	-3	0.01	3	nA
		Full	-5	-	5	nA
COM ON Leakage Current, $I_{COM(ON)}$	$V+ = 13V$, $V_{COM} = 1V, 12V$, or V_{NO} or $V_{NC} = 1V, 12V$ or floating	+25	-5	-	5	nA
		Full	-12	-	12	nA
DYNAMIC CHARACTERISTICS						
Turn-ON Time, t_{ON}	V_{NO} or $V_{NC} = 10V$, $R_L = 1k\Omega$, $C_L = 35pF$, $V_{IN} = 0V$ to $4V$	+25	-	25	-	ns
		Full	-	35	-	ns
Turn-OFF Time, t_{OFF}	V_{NO} or $V_{NC} = 10V$, $R_L = 1k\Omega$, $C_L = 35pF$, $V_{IN} = 0V$ to $4V$	+25	-	17	-	ns
		Full	-	26	-	ns
Break-Before-Make Time Delay, t_D	$R_L = 300\Omega$, $C_L = 35pF$, V_{NO} or $V_{NC} = 10V$, $V_{IN} = 0V$ to $4V$	Full	-	2	-	ns
Charge Injection, Q	$C_L = 1.0nF$, $V_G = 0V$, $R_G = 0\Omega$	+25	-	5	-	pC
OFF Isolation	$R_L = 50\Omega$, $C_L = 5pF$, $f = 1MHz$	+25	-	76	-	dB
Crosstalk (Channel-to-Channel)	$R_L = 50\Omega$, $C_L = 5pF$, $f = 1MHz$	+25	-	-105	-	dB
Power Supply Rejection Ratio	$R_L = 50\Omega$, $C_L = 5pF$, $f = 1MHz$	+25	-	63	-	dB
NO or NC OFF Capacitance, C_{OFF}	$f = 1MHz$, V_{NO} or $V_{NC} = V_{COM} = 0V$	+25	-	8	-	pF
COM OFF Capacitance, $C_{COM(OFF)}$	$f = 1MHz$, V_{NO} or $V_{NC} = V_{COM} = 0V$	+25	-	8	-	pF
COM ON Capacitance, $C_{COM(ON)}$	$f = 1MHz$, V_{NO} or $V_{NC} = V_{COM} = 0V$ (see Figure 7)	+25	-	28	-	pF
POWER SUPPLY CHARACTERISTICS						
Positive Supply Current, $I+$	$V+ = 13V$, $V_{IN} = 0V$ or $V+$, all channels on or off	Full	-1	-	1	μA

ISL76123

Electrical Specifications - 12V Supply Test Conditions: $V+ = +10.8V$ to $+13V$, $GND = 0V$, $V_{INH} = 4V$, $V_{INL} = 0.8V$ (Note 8), unless otherwise specified. **Boldface limits apply across the operating temperature range, $-40^{\circ}C$ to $+105^{\circ}C$.** (Continued)

PARAMETER	TEST CONDITIONS	TEMP ($^{\circ}C$)	MIN (Notes 9, 10)	TYP	MAX (Notes 9, 10)	UNITS
DIGITAL INPUT CHARACTERISTICS						
Input Voltage Low, V_{INL}		Full	-	-	0.8	V
Input Voltage High, V_{INH}		Full	4	-	-	V
Input Current, I_{INH} , I_{INL}	$V+ = 13V$, $V_{IN} = 0V$ or $V+$	Full	-1	-	1	μA

NOTES:

- 8. V_{IN} = input voltage to perform proper function.
- 9. The algebraic convention, whereby the most negative value is a minimum and the most positive a maximum, is used in this data sheet.
- 10. Compliance to datasheet limits is assured by one or more methods: production test, characterization and/or design.
- 11. Limits established by characterization and are not production tested.

Test Circuits and Waveforms

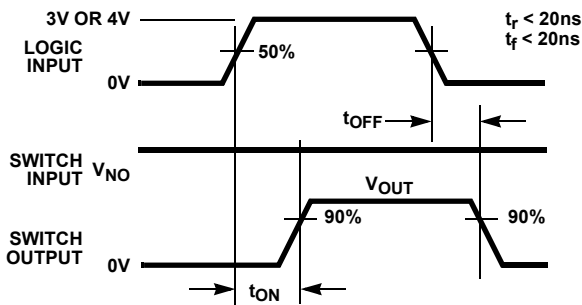

Logic input waveform is inverted for switches that have the opposite logic sense.

FIGURE 1A. MEASUREMENT POINTS

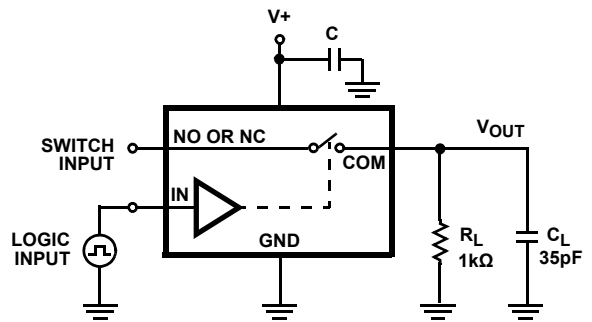

Repeat test for all switches. C_L includes fixture and stray capacitance.

$$V_{OUT} = V_{(NO\ OR\ NC)} \frac{R_L}{R_L + r_{ON}}$$

FIGURE 1B. TEST CIRCUIT

FIGURE 1. SWITCHING TIMES

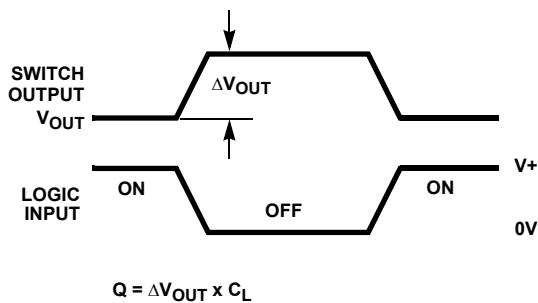

FIGURE 2A. MEASUREMENT POINTS

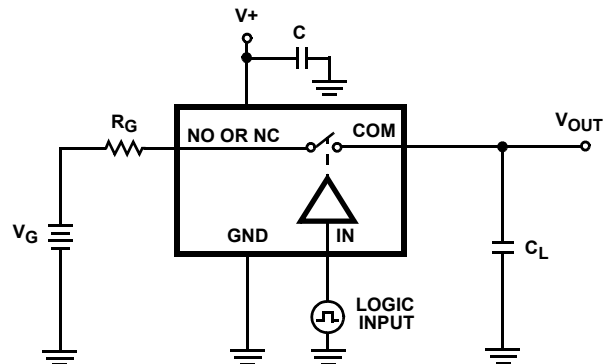

FIGURE 2B. TEST CIRCUIT

FIGURE 2. CHARGE INJECTION

Test Circuits and Waveforms (Continued)

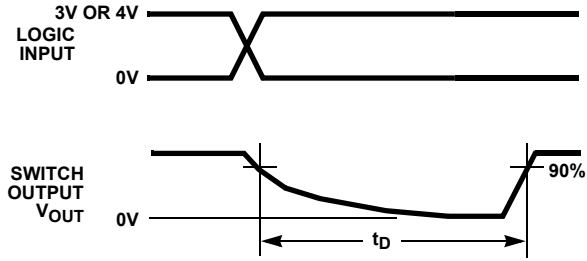
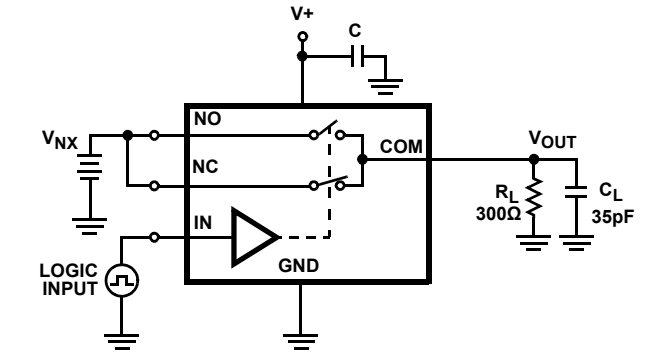

FIGURE 3A. MEASUREMENT POINTS



C_L includes fixture and stray capacitance.

FIGURE 3B. TEST CIRCUIT

FIGURE 3. BREAK-BEFORE-MAKE TIME

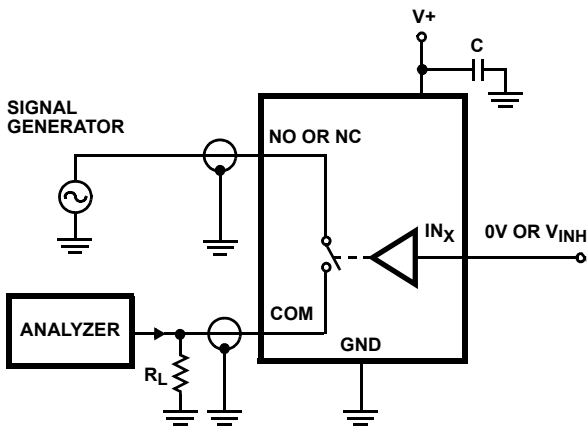

FIGURE 4. OFF ISOLATION TEST CIRCUIT

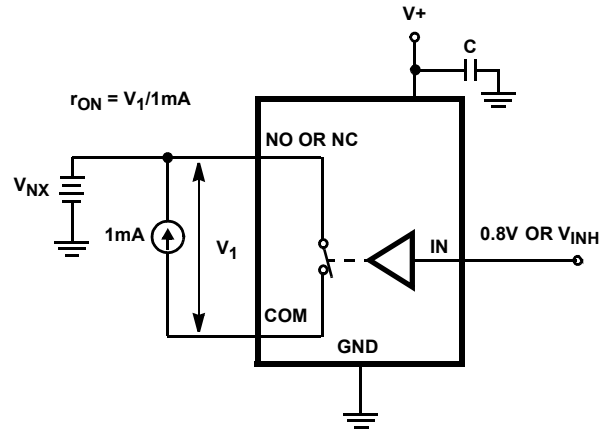

FIGURE 5. r_{ON} TEST CIRCUIT

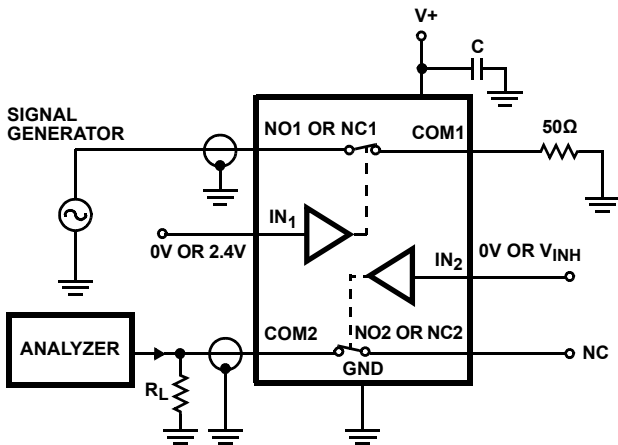

FIGURE 6. CROSSTALK TEST CIRCUIT

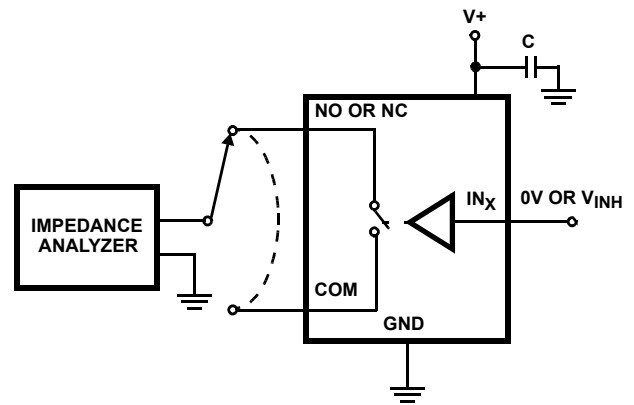

FIGURE 7. CAPACITANCE TEST CIRCUIT

Detailed Description

The ISL76123 bidirectional, single SPDT analog switch offers precise switching capability from a single 2.7V to 12V supply with low ON-resistance (23Ω) and high speed operation ($t_{ON} = 28\text{ns}$, $t_{OFF} = 20\text{ns}$). The device is especially well suited to automotive battery powered systems thanks to the low operating supply voltage (2.7V), low power consumption (5μW), low leakage currents (3nA max), and the tiny SOT-23 packaging. High frequency applications also benefit from the wide bandwidth and the very high off-isolation rejection.

Supply Sequencing and Overvoltage Protection

With any CMOS device, proper power supply sequencing is required to protect the device from excessive input currents which might permanently damage the IC. All I/O pins contain ESD protection diodes from the pin to V+ and GND (see [Figure 8](#)). To prevent forward biasing these diodes, V+ must be applied before any input signals, and input signal voltages must remain between V+ and GND. If these conditions cannot be guaranteed, then one of the following two protection methods should be employed.

Logic inputs can easily be protected by adding a 1kΩ resistor in series with the input (see [Figure 8](#)). The resistor limits the input current below the threshold that produces permanent damage, and the sub-microamp input current produces an insignificant voltage drop during normal operation.

Adding a series resistor to the switch input defeats the purpose of using a low r_{ON} switch, so two small signal diodes can be added in series with the supply pins to provide overvoltage protection for all pins (see [Figure 8](#)). These additional diodes limit the analog signal from 1V below V+ to 1V above GND. The low leakage current performance is unaffected by this approach, but the switch resistance may increase, especially at low supply voltages.

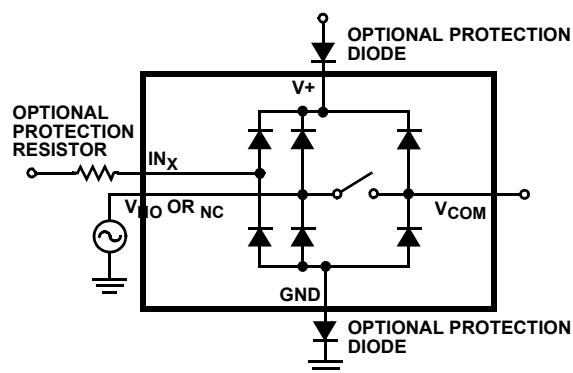

FIGURE 8. OVERVOLTAGE PROTECTION

Power-Supply Considerations

The ISL76123 construction is typical of most CMOS analog switches, except that they have only two supply pins: V+ and GND. V+ and GND drive the internal CMOS switches and set their analog voltage limits. Unlike switches with a 13V maximum supply voltage, the ISL76123 15V maximum supply voltage provides plenty of room for the 10% tolerance of 12V supplies, as well as room for overshoot and noise spikes.

The minimum recommended supply voltage is 2.7V. It is important to note that the input signal range, switching times, and ON-resistance degrade at lower supply voltages. Refer to the “Electrical Specification” tables beginning on [page 3](#) and “[Typical Performance Curves](#)” beginning on [page 9](#) for details.

V+ and GND also power the internal logic and level shifter. The level shifter converts the input logic levels to switched V+ and GND signals to drive the analog switch gate terminals.

This device cannot be operated with bipolar supplies, because the input switching point becomes negative in this configuration.

Logic-Level Thresholds

This switch is TTL compatible (0.8V and 2.4V) over a supply range of 3V to 11V (see [Figure 15](#)). At 12V the V_{IH} level is about 2.5V. This is still below the TTL guaranteed high output minimum level of 2.8V, but noise margin is reduced. For best results with a 12V supply, use a logic family that provides a V_{OH} greater than 3V.

The digital input stages draw supply current whenever the digital input voltage is not at one of the supply rails. Driving the digital input signals from GND to V+ with a fast transition time minimizes power dissipation.

High-Frequency Performance

In 50Ω systems, signal response is reasonably flat even past 300MHz (see [Figure 16](#)). [Figure 16](#) also illustrates that the frequency response is very consistent over a wide V+ range, and for varying analog signal levels.

An OFF switch acts like a capacitor and passes higher frequencies with less attenuation, resulting in signal feedthrough from a switch’s input to its output. Off-isolation is the resistance to this feedthrough. [Figure 17](#) details the high off-isolation rejection provided by this part. At 10MHz, off-isolation is about 50dB in 50Ω systems, decreasing approximately 20dB per decade as frequency increases. Higher load impedances decrease off-isolation rejection due to the voltage divider action of the switch OFF impedance and the load impedance.

Leakage Considerations

Reverse ESD protection diodes are internally connected between each analog-signal pin and both V+ and GND. One of these diodes conducts if any analog signal exceeds V+ or GND.

Virtually all the analog leakage current comes from the ESD diodes to V+ or GND. Although the ESD diodes on a given signal pin are identical and therefore fairly well balanced, they are reverse biased differently. Each is biased by either V+ or GND and the analog signal. This means their leakages will vary as the signal varies. The difference in the two diode leakages to the V+ and GND pins constitutes the analog-signal-path leakage current. All analog leakage current flows between each pin and one of the supply terminals, not to the other switch terminal. This is why both sides of a given switch can show leakage currents of the same or opposite polarity. There is no connection between the analog signal paths and V+ or GND.

Typical Performance Curves T_A = +25 °C, Unless Otherwise Specified.

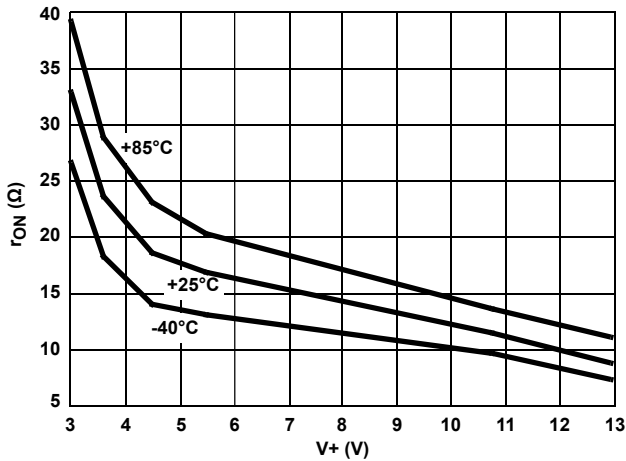

FIGURE 9. ON-RESISTANCE vs SUPPLY VOLTAGE

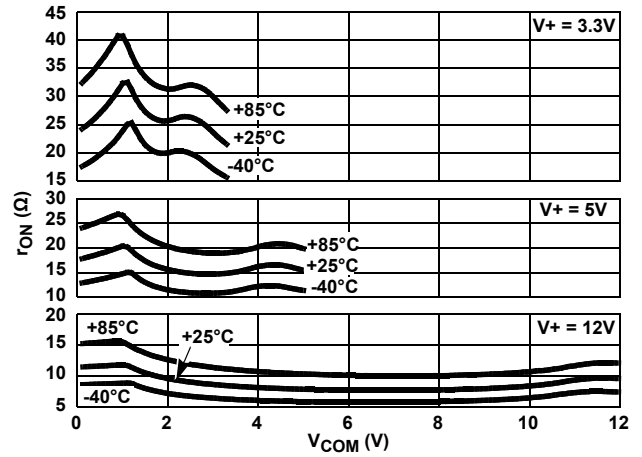

FIGURE 10. ON-RESISTANCE vs SWITCH VOLTAGE

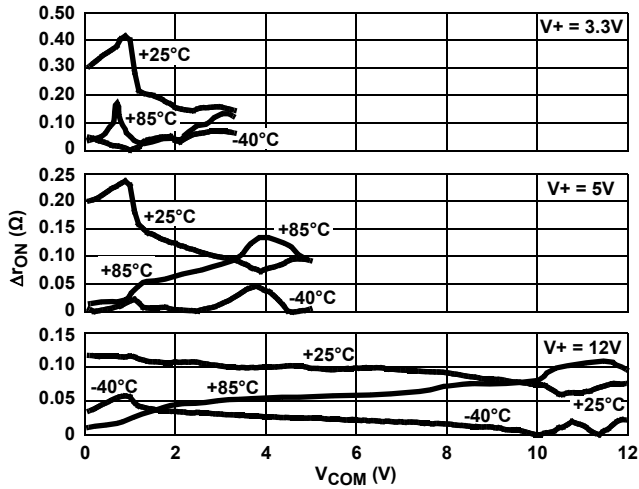

FIGURE 11. r_{ON} MATCH vs SWITCH VOLTAGE

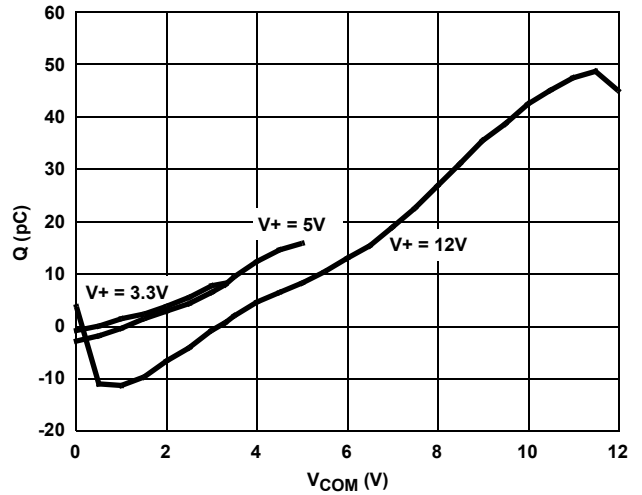

FIGURE 12. CHARGE INJECTION vs SWITCH VOLTAGE

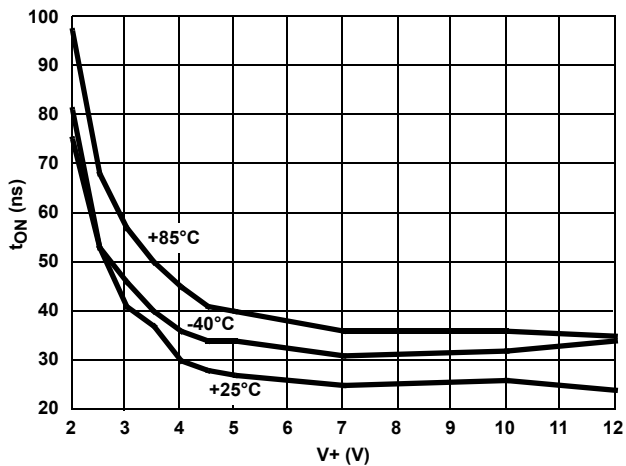

FIGURE 13. TURN-ON TIME vs SUPPLY VOLTAGE

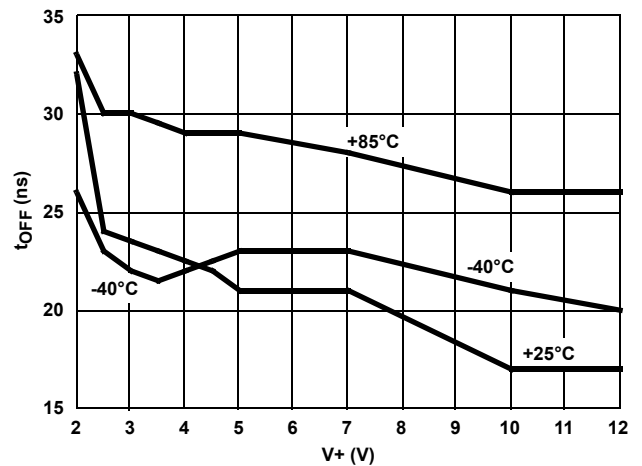

FIGURE 14. TURN-OFF TIME vs SUPPLY VOLTAGE

Typical Performance Curves T_A = +25°C, Unless Otherwise Specified. (Continued)

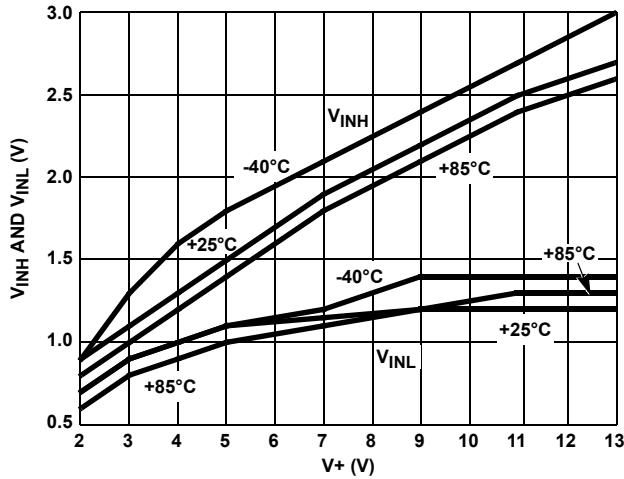

FIGURE 15. DIGITAL SWITCHING POINT vs SUPPLY VOLTAGE

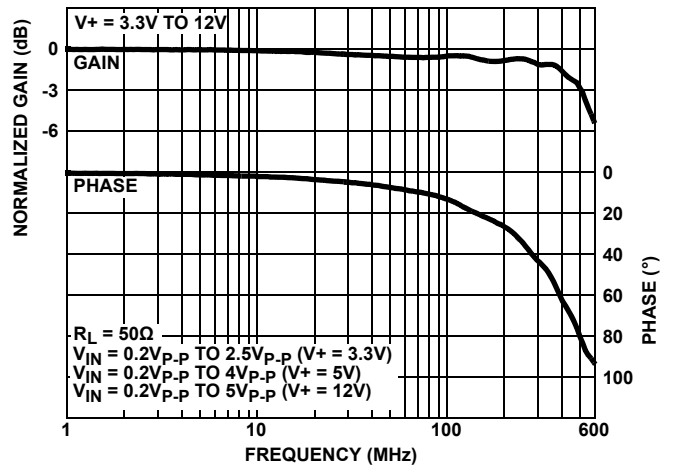

FIGURE 16. FREQUENCY RESPONSE

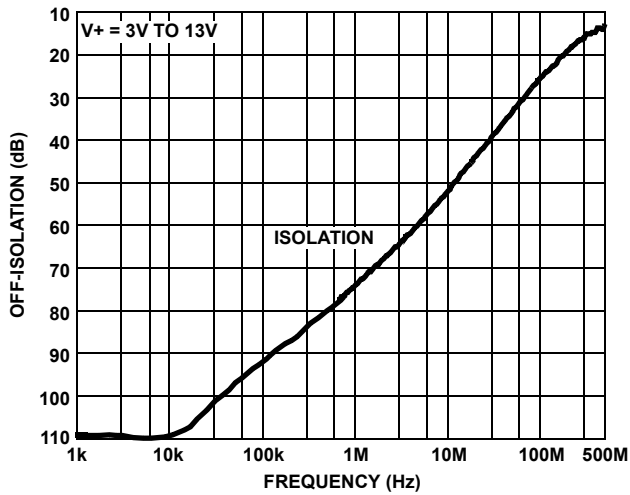

FIGURE 17. OFF-ISOLATION

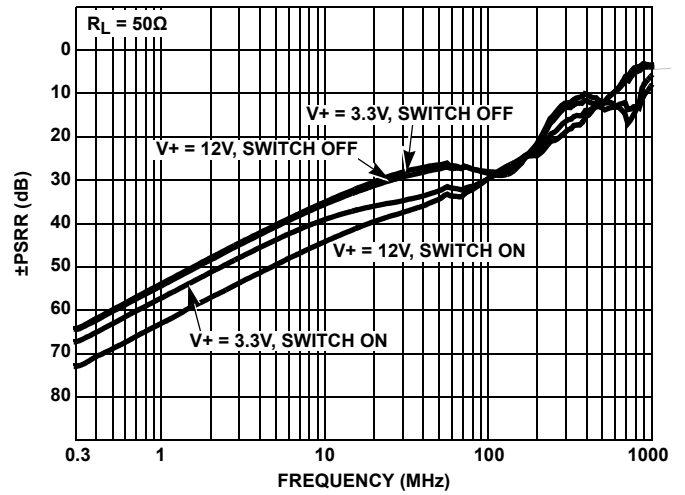

FIGURE 18. \pm PSRR vs FREQUENCY

Revision History

The revision history provided is for informational purposes only and is believed to be accurate, but not warranted. Please go to web to make sure you have the latest revision.

DATE	REVISION	CHANGE
August 15, 2014	FN8297.3	Page 3 - Changed Charged Device Model from: Charged Device Model (Tested per JESD22-C101) to: Charged Device Model (Tested per AEC-Q100-11)
December 23, 2013	FN8297.2	Page 11 - 2nd line of the disclaimer changed from: "Intersil products are manufactured, assembled and tested utilizing ISO9001 quality systems as noted" to: "Intersil Automotive Qualified products are manufactured, assembled and tested utilizing TS16949 quality systems as noted"
September 28, 2012	FN8297.1	Initial Release.

About Intersil

Intersil Corporation is a leading provider of innovative power management and precision analog solutions. The company's products address some of the largest markets within the industrial and infrastructure, mobile computing and high-end consumer markets.

For the most updated datasheet, application notes, related documentation and related parts, please see the respective product information page found at www.intersil.com.

You may report errors or suggestions for improving this datasheet by visiting www.intersil.com/ask.

Reliability reports are also available from our website at www.intersil.com/support

For additional products, see www.intersil.com/en/products.html

Intersil Automotive Qualified products are manufactured, assembled and tested utilizing TS16949 quality systems as noted in the quality certifications found at www.intersil.com/en/support/qualandreliability.html

Intersil products are sold by description only. Intersil Corporation reserves the right to make changes in circuit design, software and/or specifications at any time without notice. Accordingly, the reader is cautioned to verify that data sheets are current before placing orders. Information furnished by Intersil is believed to be accurate and reliable. However, no responsibility is assumed by Intersil or its subsidiaries for its use; nor for any infringements of patents or other rights of third parties which may result from its use. No license is granted by implication or otherwise under any patent or patent rights of Intersil or its subsidiaries.

For information regarding Intersil Corporation and its products, see www.intersil.com

Package Outline Drawing

P6.064

6 LEAD SMALL OUTLINE TRANSISTOR PLASTIC PACKAGE

Rev 4, 2/10

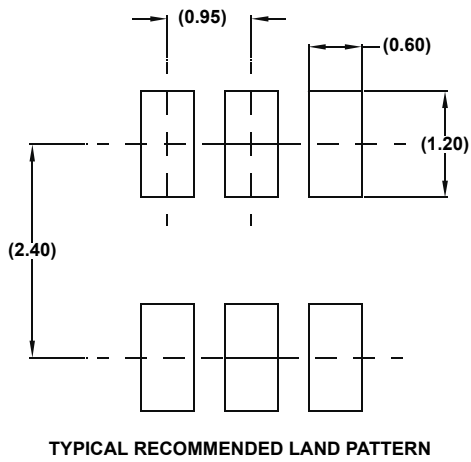
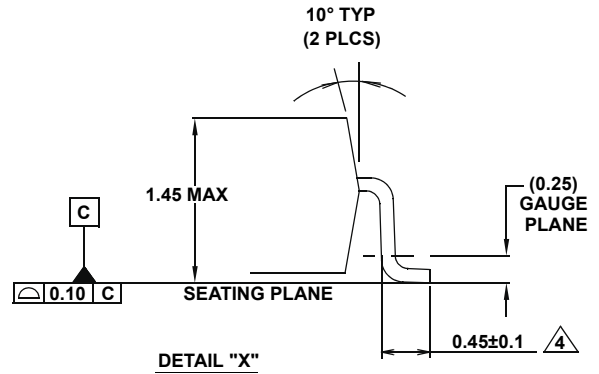
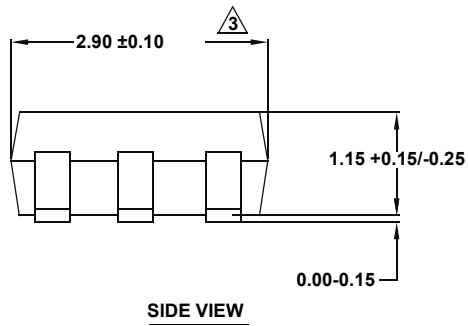
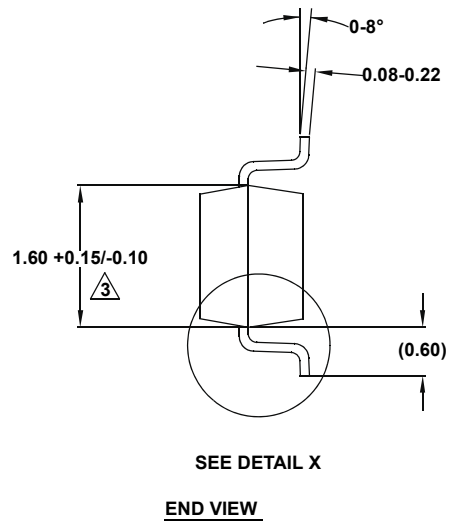
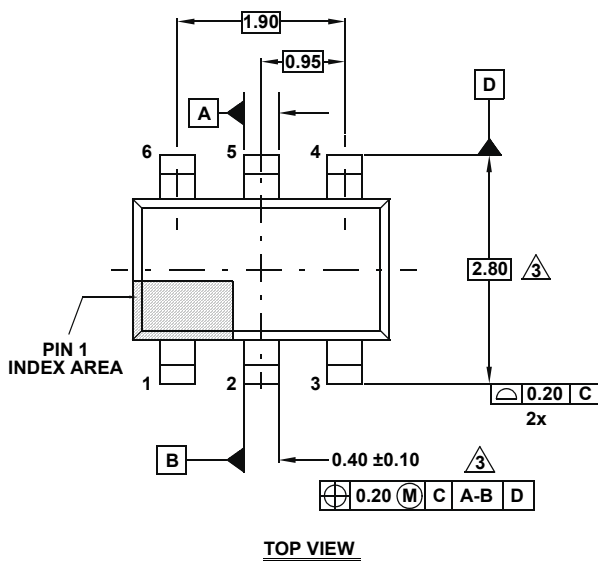

NOTES:

1. Dimensions are in millimeters.
Dimensions in () for Reference Only.
2. Dimensioning and tolerancing conform to ASME Y14.5M-1994.
3. Dimension is exclusive of mold flash, protrusions or gate burrs.
4. Foot length is measured at reference to gauge plane.
5. Package conforms to JEDEC MO-178AB.

Mouser Electronics

Authorized Distributor

Click to View Pricing, Inventory, Delivery & Lifecycle Information:

[Intersil:](#)

[ISL76123AHZ-T](#) [ISL76123AHZ-T7A](#)