



	ITC107P	Units
Hook Switch Breakdown Voltage	350	V
Bridge Rectifier Reverse Voltage	350	V

### Features

- Small 16 Pin SOIC Package (PCMCIA Compatible)
- Board Space and Cost Savings
- No Moving Parts
- 3750V<sub>RMS</sub> Input/Output Isolation
- FCC Compatible Part 68
- Photodarlington Hook Switch
- Full-Wave Bridge Rectifier
- Darlington Transistor for Electronic Inductor “Dry” Circuits
- Full Wave Current Detector for Ring Signal or Loop Current Detect
- JEDEC Standard Pin Out

### Applications

- Data/Fax Modem
- Voice Mail Systems
- Telephone Sets
- Computer Telephony Integration
- Set Top Box Modems

### Description

The Integrated Telecom Circuit combines a high voltage optically isolated photodarlington, bridge rectifier, Darlington transistor and optocoupler into one 16 pin SOIC package, consolidating designs and reducing component count in telecom applications. The ITC107's optocoupler provides for full wave detection of ring signals.

### Approvals

- UL Recognized
- Complies with EN 60950

### Ordering Information

Part #	Description
ITC107P	16 Pin SOIC (50/Tube)
ITC107PTR	16 Pin SOIC (1000/Reel)

### Pin Configuration

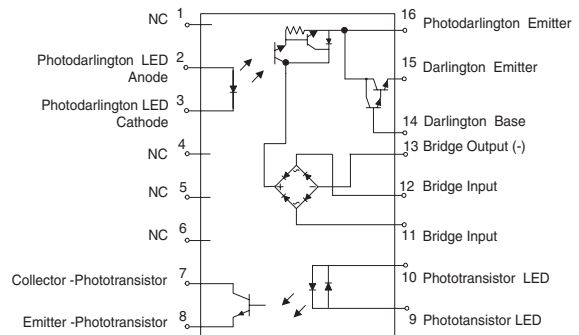

**Absolute Maximum Ratings (@ 25° C)**

Parameter	Min	Typ	Max	Units
Total Package Dissipation	-	-	1 <sup>1</sup>	W
Isolation Voltage				
Input to Output	3750	-	-	V <sub>RMS</sub>
Operational Temperature	-40	-	+85	°C
Storage Temperature	-40	-	+125	°C
Soldering Temperature (10 Seconds Max.)	-	-	+220	°C

<sup>1</sup> Above 25° derate linearly 8.33mw/°C

Total Power Dissipation (PD):

$$P_D = P_{\text{HOOKSWITCH}} + P_{\text{BRIDGE}} + P_{\text{DARLINGTON}} + P_{\text{LED}}$$

$$P_D = (R_{DS(on)})(I_L^2) + 2(V_F)(I_L) + (V_{CE})(I_L) + (V_{LED})(I_F)$$

WHERE:

R<sub>DS(on)</sub> = Maximum rds on resistance

I<sub>L</sub> = Maximum loop current

V<sub>F</sub> = Maximum diode forward voltage

V<sub>CE</sub> = Maximum voltage collector to emitter

V<sub>LED</sub> = Maximum LED forward voltage

I<sub>F</sub> = Maximum LED current

*Absolute Maximum Ratings are stress ratings. Stresses in excess of these ratings can cause permanent damage to the device. Functional operation of the device at conditions beyond those indicated in the operational sections of this data sheet is not implied.*

**Electrical Characteristics**

Parameter	Condition	Symbol	Min	Typ	Max	Units
<b>Photodarlington Portion</b>						
Collector-Emitter Breakdown voltage	I <sub>C</sub> = 100uA	B <sub>VCEO</sub>	350	-	-	V
Collector Dark Current	V <sub>CE</sub> = 200V	I <sub>CEO</sub>	-	-	100	nA
Collector Emitter Saturation Voltage	I <sub>C</sub> = 100mA I <sub>B</sub> = 150uA	V <sub>CE(S)</sub>	-	-	1.2	V
Current Gain	Hfe	I <sub>C</sub> = 40mA V <sub>CE</sub> = 2V	2500	-	40000	-
LED Input control Current	-	I <sub>F</sub>	5	-	50	mA
LED input Voltage Drop	I <sub>F</sub> = 5mA	V <sub>F</sub>	0.9	1.2	1.4	V
LED Reverse Input Voltage	-	V <sub>R</sub>	-	-	5	V
LED Reverse Input Current	I <sub>R</sub> = 5V	I <sub>R</sub>	-	-	10	mA
<b>Phototransistor Portion</b>						
Phototransistor Blocking Voltage	I <sub>C</sub> = 10uA	B <sub>VCEO</sub>	20	50	-	V
Phototransistor Dark Current	V <sub>CC</sub> = 5V I <sub>F</sub> = 0mA	I <sub>CEO</sub>	-	50	500	mA
Saturation Voltage	I <sub>C</sub> = 2mA I <sub>F</sub> = 16mA	V <sub>SAT</sub>	-	0.3	0.5	V
Current Transfer Ratio	V <sub>CE</sub> = 0.5V I <sub>F</sub> = 6mA	CTR	33	400	-	%
LED Input control Current	V <sub>CE</sub> = 0.5V I <sub>C</sub> = 2mA	I <sub>F</sub>	6	2	100	mA
LED input Voltage Drop	I <sub>F</sub> = 5mA	V <sub>F</sub>	0.9	1.2	1.4	V
LED Input Current (Detector must be off)	V <sub>CE</sub> = 5V I <sub>C</sub> = 10uA	I <sub>F</sub>	5	25	-	uA
<b>Bridge Rectifier Portion</b>						
Reverse Voltage	-	V <sub>RD</sub>	-	-	350	V
Forward Voltage Drop	I <sub>FD</sub> = 120mA	V <sub>FD</sub>	-	-	1.1	V

**Electrical Characteristics**

Parameter	Condition	Symbol	Min	Typ	Max	Units
Reverse Leakage Current	$V_R = 350V$	$I_{RD}$	-	-	10	$\mu A$
	$T_J = 25^\circ C$				50	$\mu A$
Forward Current Continuous		$I_{FD}$	-	-	140	mA
Forward Current Peak	$T = 10mS$	$I_{FD}$	-	-	0.5	A
<b>Darlington Portion</b>						
Collector Emitter Voltage	$I_C = 10mA$ DC $I_B = 0$	$V_{CEO}$	20	-	-	V
Collector Current Continuous	$V_C = 3.5V$	$I_C$	-	-	120	mA
Off – State Collector Emitter Leakage Current	$V_{CE} = 10V$ $I_B = 0mA$	$I_{CEX}$	-	-	1	$\mu A$
DC Gain Current	$V_{CE} = 5VDC$ $I_C = 100mA$	$h_{FE}$	300	-	-	-
Saturation Voltage	$I_C = 120mA$	$V_{CE(SAT)}$	-	-	1.5	V
Total Harmonic Distortion	$F_0 = 300Hz$ @ -10dBm $I_C = 40mA$	-	-	-	-80	dB

**MECHANICAL DIMENSIONS**

**16 Pin SOIC ("P" Suffix)**

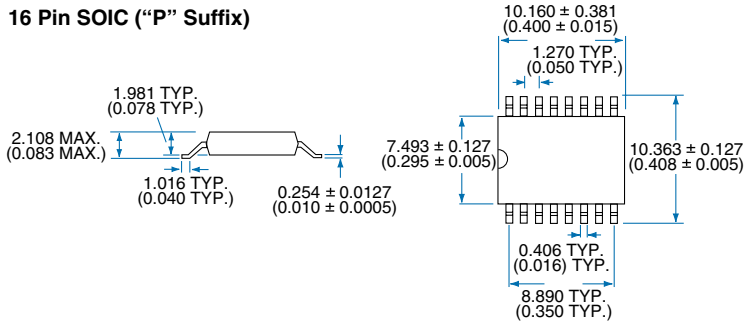

**PC Board Pattern (Top View)**

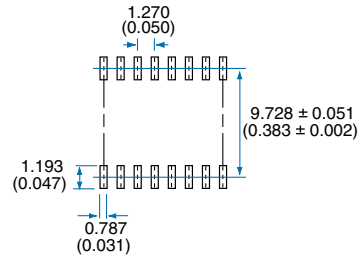

**Tape and Reel Packaging for 16 Pin SOIC Package**

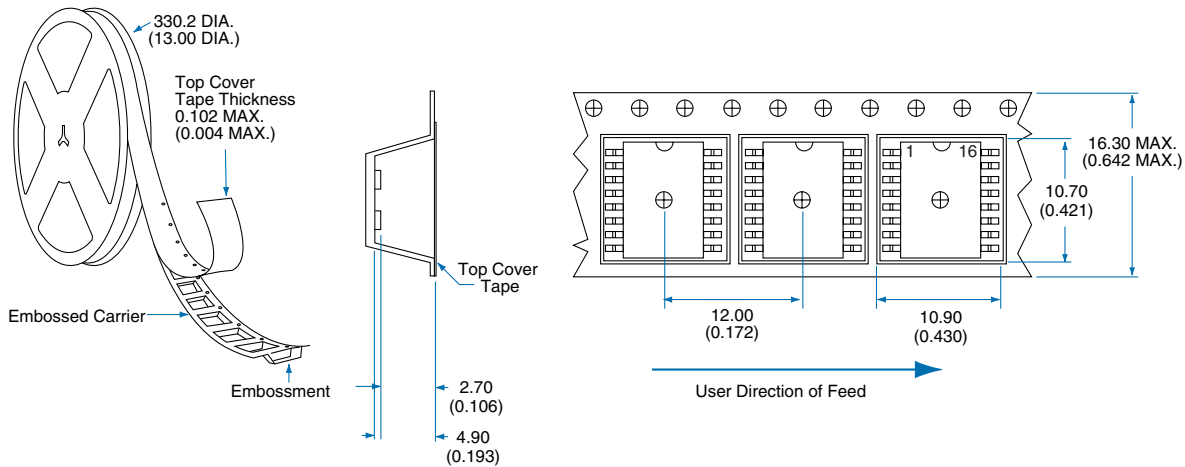

**Dimensions**  
mm  
(inches)

**For additional information please visit our website at: [www.clare.com](http://www.clare.com)**

*Clare, Inc. makes no representations or warranties with respect to the accuracy or completeness of the contents of this publication and reserves the right to make changes to specifications and product descriptions at any time without notice. Neither circuit patent licenses nor indemnity are expressed or implied. Except as set forth in Clare's Standard Terms and Conditions of Sale, Clare, Inc. assumes no liability whatsoever, and disclaims any express or implied warranty, relating to its products including, but not limited to, the implied warranty of merchantability, fitness for a particular purpose, or infringement of any intellectual property right.*

*The products described in this document are not designed, intended, authorized or warranted for use as components in systems intended for surgical implant into the body, or in other applications intended to support or sustain life, or where malfunction of Clare's product may result in direct physical harm, injury, or death to a person or severe property or environmental damage. Clare, Inc. reserves the right to discontinue or make changes to its products at any time without notice.*

Specification: DS-ITC107P-R1.2  
©Copyright 2003, Clare, Inc.  
OptoMOS® is a registered trademark of Clare, Inc.  
All rights reserved. Printed in USA.  
2/24/03