

Stereo Audio Subsystem with Class G Headphone Amplifier and Class D Speaker Amplifier with Speaker Protection

General Description

The LM49251 is a fully integrated audio subsystem designed for portable handheld applications such as cellular phones. Part of National's PowerWise family of products, the LM49251 utilizes a high efficiency class G headphone amplifier topology as well as a high efficiency class D loudspeaker. The headphone amplifiers feature National's class G ground referenced architecture that creates a ground-referenced output with dynamic supply rails for optimum efficiency. The stereo class D speaker amplifier provides both a no-clip feature and speaker protection. The Enhanced Emission Suppression (E²S) outputs feature a patented, ultra low EMI PWM architecture that significantly reduces RF emissions.

The LM49251 features separate volume controls for the mono and stereo inputs. Mode selection, shutdown control, and volume are controlled through an I²C compatible interface.

Click and pop suppression eliminates audible transients on power-up/down and during shutdown. The LM49251 is available in an ultra-small 30-bump micro SMD package (2.55mmx3.02mm)

Key Specifications

- Class G Headphone Amplifier, $HPV_{DD} = 1.8V$, $R_L = 32\Omega$
 $IDDQ_{HP} = 1.15mA$ (typ)
 Output Power, $THD+N \leq 1\%$ = 20mW (typ)
- Stereo Class D Speaker Amplifier $R_L = 8\Omega$
 Output Power, $THD+N \leq 1\%$, $LSV_{DD} = 5.0V$ = 1.37W (typ)
 Output Power, $THD+N \leq 1\%$, $LSV_{DD} = 3.6V$ = 680mW (typ)
 Efficiency = 90% (typ)

Features

- Class G Ground Referenced Headphone Outputs
- E²S Class D Amplifier
- No Clip Function
- Power Limiter Speaker Protection
- I²C Volume and Mode Control
- Advanced Click-and-Pop Suppression
- Micro-power shutdown

Applications

- Feature Phones
- Smart phones

Simplified Block Diagram

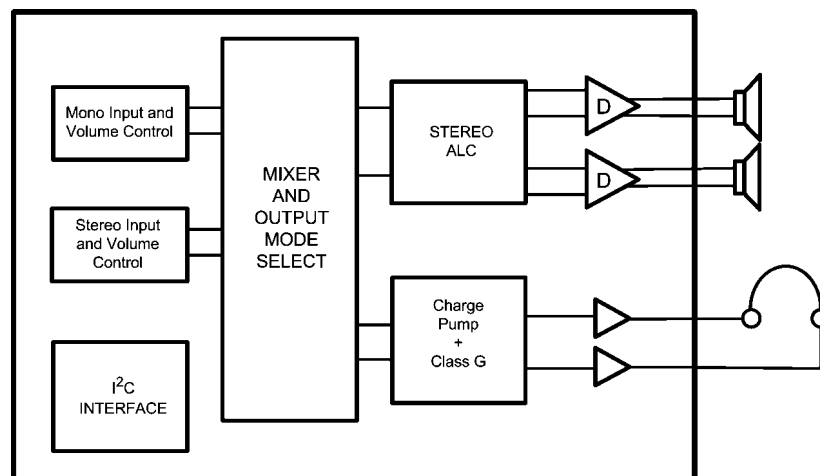

30121825

FIGURE 1. LM49251 Simplified Block Diagram

Boomer® is a registered trademark of National Semiconductor Corporation.

Typical Application

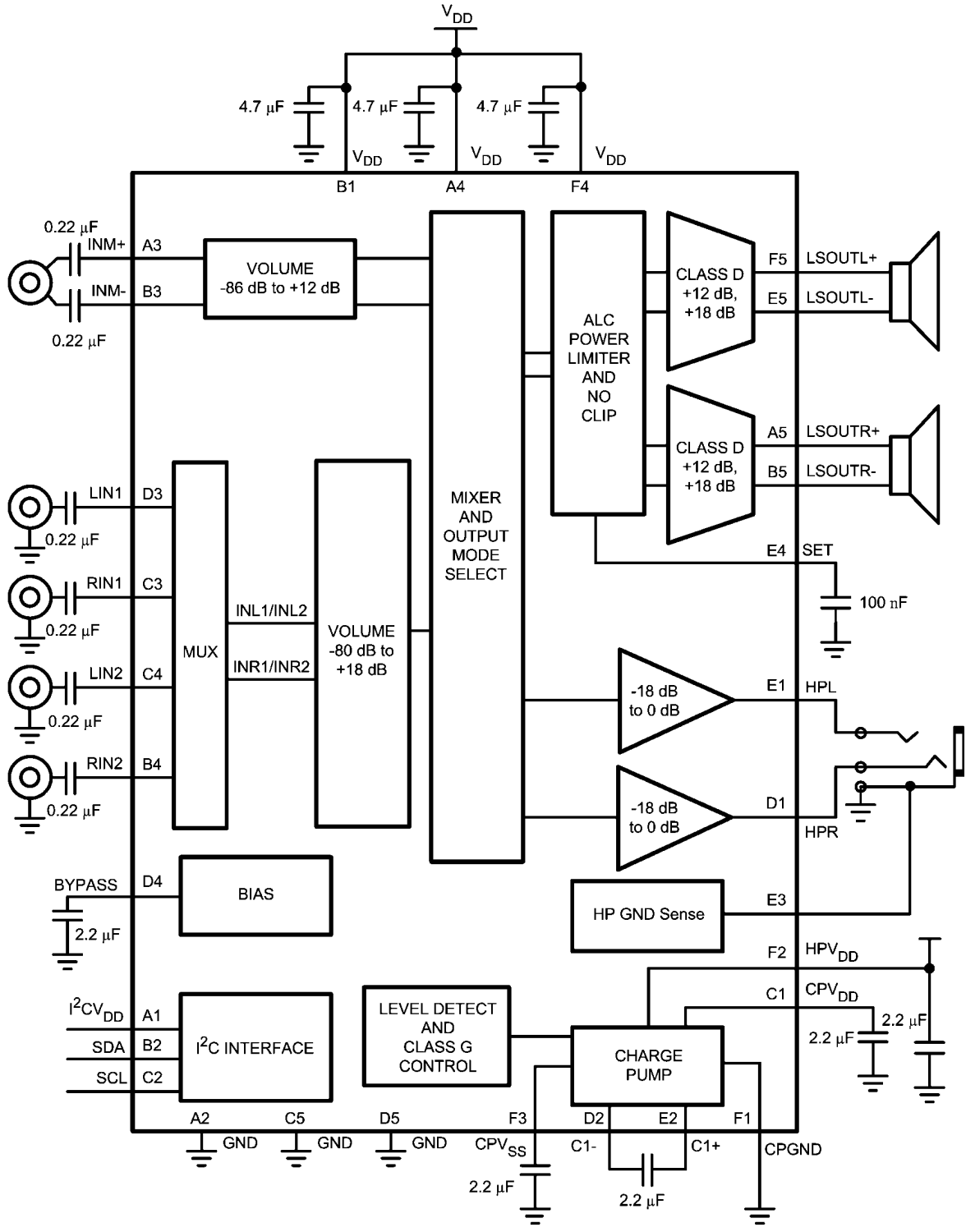

30121826

FIGURE 2. Typical Audio Amplifier Application Circuit

Connection Diagrams

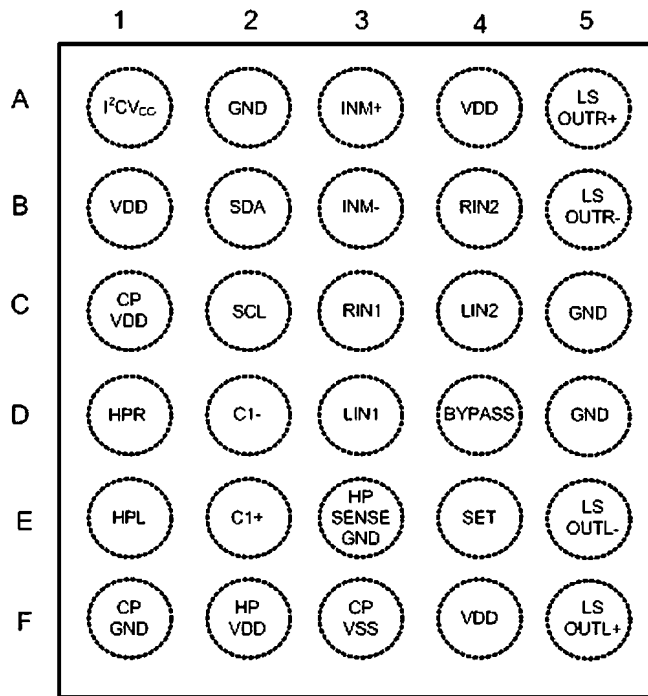

30121861

Top View
Order Number LM49251TL
See NS Package Number TLA30B1A

30 – Bump micro SMD Marking

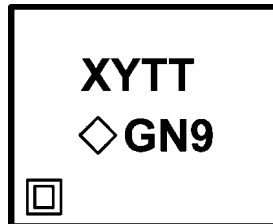

30121850

Top View
XY = Date Code
TT = Die Traceability
G = Boomer Family
N9 = LM49251TL

Ordering Information

Order Number	Package	Package DWG #	Transport Media	MSL Level	Green Status
LM49251TL	Micro SMD	TLA30B1A	250 units on tape and reel	1	RoHS
LM49251TLX	Micro SMD	TLA30B1A	3000 units on tape and reel	1	RoHS

TABLE 1. Bump Description

Bump	Name	Description
A1	I ² CV _{DD}	I ² C Power Supply
A2	GND	Ground
A3	INM+	Mono Channel Non-Inverting Input
A4	V _{DD}	Loudspeaker Power Supply
A5	LSOUTR+	Right Loudspeaker Non-Inverting Output
B1	V _{DD}	Loudspeaker Power Supply
B2	SDA	I ² C Serial Data Input
B3	INM-	Mono Channel Inverting Input
B4	RIN2	Right Channel Input 2
B5	LSOUTR-	Right Loudspeaker Inverting Output
C1	CPV _{DD}	Charge Pump Supply (internally generated)
C2	SCL	I ² C Serial Clock Input
C3	RIN1	Right Channel Input 1
C4	LIN2	Left Channel Input 2
C5	GND	Ground
D1	HPR	Right Channel Headphone Output
D2	C1-	Charge Pump Flying Capacitor Negative Terminal
D3	LIN1	Left Channel Input 1
D4	BYPASS	Mid-Rail Bias Bypass Node
D5	GND	Ground
E1	HPL	Left Channel Headphone Output
E2	C1+	Charge Pump Flying Capacitor Positive Terminal
E3	HP SENSE GND	Headphone Ground Sense
E4	SET	ALC Timing Set
E5	LSOUTL-	Left Loudspeaker Inverting Output
F1	CPGND	Charge Pump Ground
F2	HPV _{DD}	Headphone Power Supply
F3	CPV _{SS}	Charge Pump Output
F4	V _{DD}	Loudspeaker Power Supply
F5	LSOUTL+	Left Loudspeaker Non-Inverting Output

Absolute Maximum Ratings (Note 1, Note 2)

If Military/Aerospace specified devices are required, please contact the National Semiconductor Sales Office/Distributors for availability and specifications.

Supply Voltage (Note 1)

V_{DD} , $I^2C_{V_{DD}}$	6V
HPV _{DD}	3V
Storage Temperature	-65°C to +150°C
Input Voltage	-0.3V to V_{DD} +0.3V
Power Dissipation <small>(Note 3)</small>	Internally Limited
ESD HBM <small>(Note 4)</small>	2000V
ESD MM <small>(Note 5)</small>	150V
ESD CDM <small>(Note 10)</small>	750V

Junction Temperature	150°C
Thermal Resistance	
θ_{JA} (TLA30B1A)	90°C/W
Soldering Information	
See AN-1112 "Micro SMD Wafer Level Chip Scale Package"	

Operating Ratings

Temperature Range		
$T_{MIN} \leq T_A \leq T_{MAX}$		-40°C \leq T_A \leq +85°C
Supply Voltage		
V_{DD}		2.7V \leq V_{DD} \leq 5.5V
HPV _{DD}		1.6V \leq HPV _{DD} \leq 2.0V
I^2C_{DD}		1.7V \leq $I^2C_{V_{DD}}$ \leq 5.5V

Electrical Characteristics (Note 1, Note 2)

The following specifications apply for $A_V = 0$ dB, $R_L = 15\mu\text{H} + 8\Omega + 15\mu\text{H}$ (Loudspeaker), $R_L = 32\Omega$ (Headphone), $C_{SET} = 100\text{nF}$, $f = 1\text{kHz}$, ALC off, unless otherwise specified. Limits apply for $T_A = 25^\circ\text{C}$.

Symbol	Parameter	Conditions	LM49251		Units (Limits)
			Typical	Limit	
			<small>(Note 6)</small>	<small>(Note 7)</small>	
I_{DD}	Quiescent Power Supply Current (LSV _{DD} + V _{DD})	$V_{IN} = 0$, No Load			
		LS Mode (stereo input), mode 2	5.6	6.25	mA (max)
		LS Mode (mono input), mode 3	5.3	6.0	mA (max)
		HP Mode (stereo input), mode 6	2.1	2.4	mA (max)
		HP Mode (mono input), mode 4	1.8	2.0	mA (max)
		LS+HP Mode (stereo input), mode 8	6.1	6.8	mA (max)
		LS+HP Mode (mono input), mode 5	5.8	6.5	mA (max)
$I_{DD(HP)}$	Quiescent Power Supply Current (HPV _{DD})	$V_{IN} = 0$, No Load Mode 6	1.15	1.45	mA (max)
		Operating Power Supply Current (HPV _{DD})	$P_{OUT} = 0.5\text{mW}$, GAMP_SD = 0, $R_L = 32\Omega$, Mode 6	4.3	4.6
	$P_{OUT} = 1\text{mW}$, GAMP_SD = 0, $R_L = 32\Omega$, Mode 6		5.8	6.15	mA (max)
I_{SD}	Shutdown Current		0.02	1	μA (max)
V_{OS}	Output Offset Voltage	$V_{IN} = 0$ Mode 3, mono input, $A_V = 6\text{dB}$	12		mV (max)
		Mode 4, mono input	1.1		mV (max)
		Mode 2, stereo input, $A_V = 6\text{dB}$	12		mV (max)
		Mode 6, stereo input	1.1		mV (max)
T_{WU}	Wake Up Time	HP mode, $C_{BYPASS} = 2.2\mu\text{F}$			
		Normal turn on time	31		ms
		Fast turn on time	16		ms
A_{VOL}	Volume Control	Minimum Gain Setting (mono input), Mode 3	-86		dB (max) dB (min)
		Maximum Gain Setting (mono input), Mode 3	12	13 11.5	dB (max) dB (min)
		Minimum Gain Setting (stereo input), Mode 6	-80		dB (max) dB (min)
		Maximum Gain Setting (stereo input), Mode 6	18	19 17.5	dB (max) dB (min)
	Volume Control Step Error		± 0.2		dB

Symbol	Parameter	Conditions	LM49251		Units (Limits)
			Typical	Limit	
			(Note 6)	(Note 7)	
A_V	Gain	LS Mode			
		Gain 0	12	11.5 12.5	dB (min) dB (max)
		Gain 1	18	17.5 19	dB (min) dB (max)
		HP Mode			
		Gain 0	0	-0.5 0.5	dB (min) dB (max)
		Gain 1	-1.7		dB
		Gain 2	-3		dB
		Gain 3	-6		dB
		Gain 4	-9		dB
		Gain 5	-12		dB
		Gain 6	-15		dB
		Gain 7	-18	-18.5 -17.5	dB (min) dB (max)
$A_{V(MUTE)}$	Mute Attenuation	LS Output HP Output	-93 -98		dB dB
R_{IN}	Input Resistance	MONO, R_{IN} , L_{IN} inputs			
		Maximum Gain Setting	13	9.5 15.5	k Ω (min) k Ω (max)
		Minimum Gain Setting	110	97 122	k Ω (min) k Ω (max)
P_O	Output Power	Mode 3, $A_V = 18\text{dB}$, $R_L = 8\Omega$			
		$LSV_{DD} = 3.3\text{V}$	570		mW
		$LSV_{DD} = 3.6\text{V}$	680	600	mW (min)
		$LSV_{DD} = 4.2\text{V}$	955		mW
		$LSV_{DD} = 5.0\text{V}$	1370		mW
		Mode 6			
		$R_L = 16\Omega$	20		mW
$R_L = 32\Omega$	20	16	mW (min)		
THD+N	Total Harmonic Distortion + Noise	f = 1kHz, Mode 3 Mono Input, $P_O = 250\text{mW}$	0.02		%
		f = 1kHz, Mode 6 Stereo Input, $P_O = 12\text{mW}$	0.02		%
PSRR	Power Supply Rejection Ratio	f = 217Hz, $V_{RIPPLE} = 200\text{mV}_{P-P}$, Inputs AC GND, $C_B = 2.2\mu\text{F}$			
		Mode 3, mono input, $A_V = 6\text{dB}$	77		dB
		Mode 2, stereo input, $A_V = 6\text{dB}$	65		dB
		Mode 4, ripple on V_{DD} , mono input	93		dB
		Mode 4, ripple on HPV_{DD} , mono input	83		dB
		Mode 6, ripple on V_{DD} , stereo input	80		dB
		Mode 6, ripple on HPV_{DD} , stereo input	80		dB

Symbol	Parameter	Conditions	LM49251		Units (Limits)
			Typical	Limit	
			(Note 6)	(Note 7)	
CMRR	Common Mode Rejection Ratio	$V_{\text{RIPPLE}} = 1V_{\text{P-P}}, f_{\text{RIPPLE}} = 217\text{Hz}$, mono input			
		Mode 3	52		dB
		Mode 4	63		dB
η	Efficiency	LS Mode, $P_{\text{O}} = 680\text{mW}$	90		%
X_{TALK}	Crosstalk	$P_{\text{O}} = 12\text{mW}$, $f = 1\text{kHz}$, Mode 6	84		dB
ϵ_{OS}	Output Noise	A-weighted, Inputs AC GND			
		Mode 3, mono input	44		μV
		Mode 2, stereo input	45		μV
		Mode 4, mono input	8		μV
SNR	Signal-To-Noise-Ratio	Mode 3, $P_{\text{O}} = 680\text{mW}$	94		dB
		Mode 6, $P_{\text{O}} = 20\text{mW}$	98		dB
t_{A}	Attack Time	Step 1, Mode 1	0.75		ms
t_{R}	Release Time	Step 1, Mode 1	1		s
V_{LIMIT}	Output Voltage Limit	Mode 3, $\text{THD+N} \leq 1\%$, Note 9			
		Voltage Level			
		Step 1 001	3.9		$V_{\text{P-P}}$
		Step 2 010	4.7		$V_{\text{P-P}}$
		Step 3 011	5.4		$V_{\text{P-P}}$
		Step 4 100	6.2		$V_{\text{P-P}}$
		Step 5 101	7.0		$V_{\text{P-P}}$
Step 6 110	7.8		$V_{\text{P-P}}$		

I²C Interface Characteristics $V_{DD} = 5V, 2.2V \leq I^2CV_{DD} \leq 5.5V$ (Note 1, Note 2) The following specifications apply for $A_V = 0dB, R_L = 8\Omega, f = 1kHz$, unless otherwise specified. Limits apply for $T_A = 25^\circ C$.

Symbol	Parameter	Conditions	LM49251		Units (Limits)
			Typical	Limit	
			(Note 6)	(Note 7)	
t_1	SCL Period			2.5	μs (min)
t_2	SDA Set-up Time			100	ns (min)
t_3	SDA Stable Time			0	ns (min)
t_4	Start Condition Time			100	ns (min)
t_5	Stop Condition Time			100	ns (min)
t_6	SDA Hold time			100	ns (min)
V_{IH}	Input High Voltage			$0.7 \cdot I^2CV_{DD}$	V (min)
V_{IL}	Input Low Voltage			$0.3 \cdot I^2CV_{DD}$	V (max)

I²C Interface Characteristics $V_{DD} = 5V, 1.8V \leq I^2CV_{DD} \leq 2.2V$ (Note 1, Note 2) The following specifications apply for $A_V = 0dB, R_L = 8\Omega, f = 1kHz$, unless otherwise specified. Limits apply for $T_A = 25^\circ C$.

Symbol	Parameter	Conditions	LM49251		Units (Limits)
			Typical	Limit	
			(Note 6)	(Note 7)	
t_1	SCL Period			2.5	μs (min)
t_2	SDA Set-up Time			250	ns (min)
t_3	SDA Stable Time			0	ns (min)
t_4	Start Condition Time			250	ns (min)
t_5	Stop Condition Time			250	ns (min)
t_6	SDA Hold Time			250	ns (min)
V_{IH}	Digital Input High Voltage			$0.7 \cdot I^2CV_{DD}$	V (min)
V_{IL}	Digital Input Low Voltage			$0.3 \cdot I^2CV_{DD}$	V (max)

Note 1: Absolute Maximum Ratings indicate limits beyond which damage to the device may occur, including inoperability and degradation of device reliability and/or performance. Functional operation of the device and/or non-degradation at the Absolute Maximum Ratings or other conditions beyond those indicated in the Recommended Operating Conditions is not implied. The Recommended Operating Conditions indicate conditions at which the device is functional and the device should not be operated beyond such conditions. All voltages are measured with respect to the ground pin, unless otherwise specified.

Note 2: The Electrical Characteristics tables list guaranteed specifications under the listed Recommended Operating Conditions except as otherwise modified or specified by the Electrical Characteristics Conditions and/or Notes. Typical specifications are estimations only and are not guaranteed.

Note 3: The maximum power dissipation must be derated at elevated temperatures and is dictated by T_{JMAX}, θ_{JA} , and the ambient temperature, T_A . The maximum allowable power dissipation is $P_{DMAX} = (T_{JMAX} - T_A) / \theta_{JA}$ or the number given in Absolute Maximum Ratings, whichever is lower.

Note 4: Human body model, applicable std. JESD22-A114C.

Note 5: Machine model, applicable std. JESD22-A115-A.

Note 6: Typical values represent most likely parametric norms at $T_A = +25^\circ C$, and at the Recommended Operation Conditions at the time of product characterization and are not guaranteed.

Note 7: Datasheet min/max specification limits are guaranteed by test or statistical analysis.

Note 8: Loudspeaker R_L is a resistive load in series with two inductors to simulate an actual speaker load. For $R_L = 8\Omega$, the load is $15\mu H + 8\Omega + 15\mu H$. For $R_L = 4\Omega$, the load is $15\mu H + 4\Omega + 15\mu H$.

Note 9: The LM49251 ALC limits the output power to which ever is lower, the supply voltage or output power limit.

Note 10: Charge device model, applicable std. JESD22-C101D.

Typical Performance Characteristics

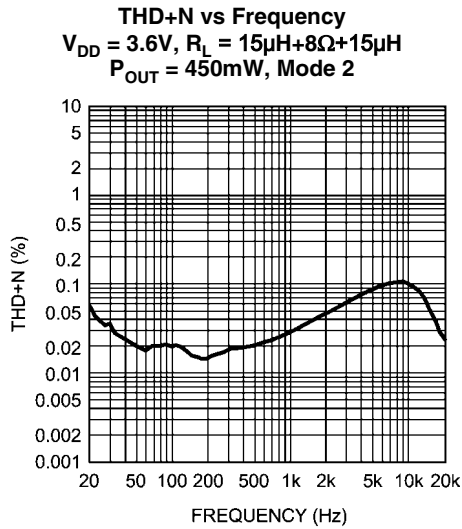

30121865

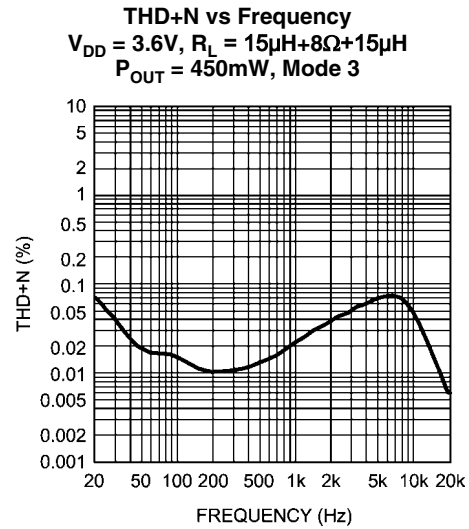

30121866

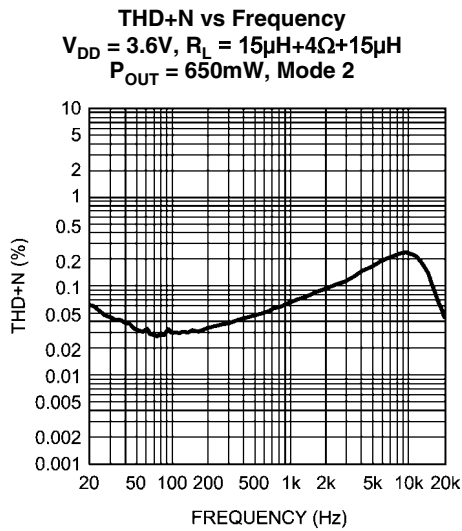

30121867

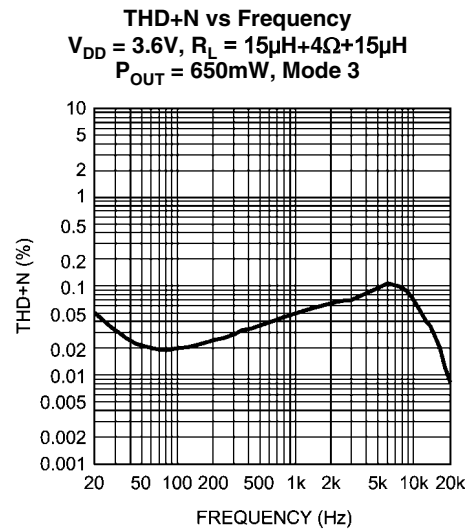

30121868

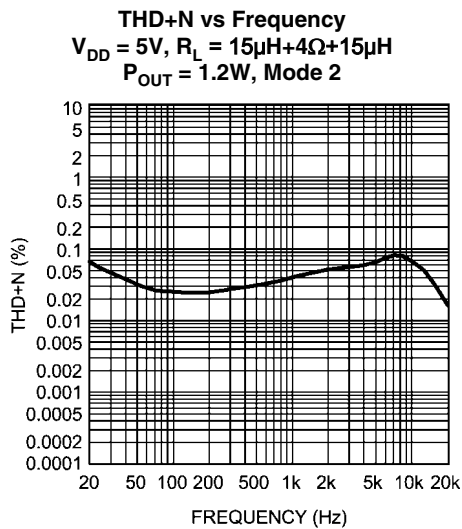

30121869

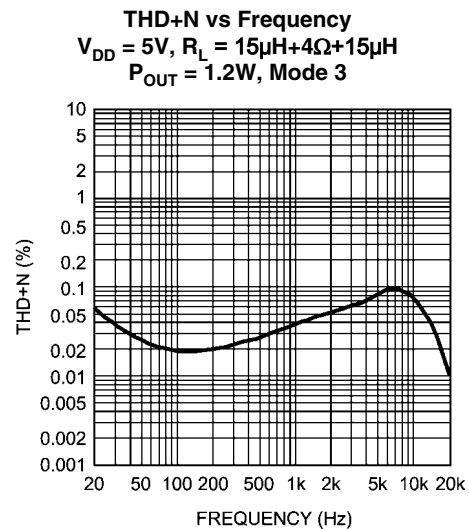

30121870

THD+N vs Frequency
 $V_{DD} = 5V, R_L = 15\mu H + 8\Omega + 15\mu H$
 $P_{OUT} = 50mW, \text{Mode 3}$

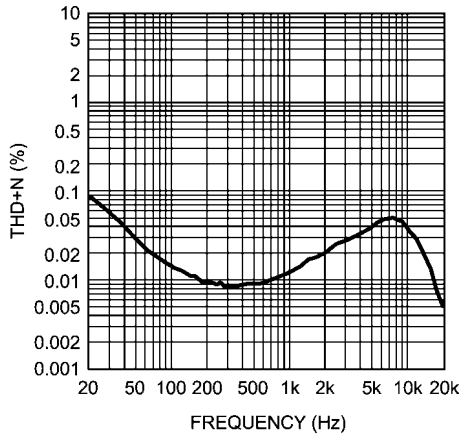

30121871

THD+N vs Frequency
 $V_{DD} = 5V, R_L = 5\mu H + 8\Omega + 15\mu H$
 $P_{OUT} = 750mW, \text{Mode 2}$

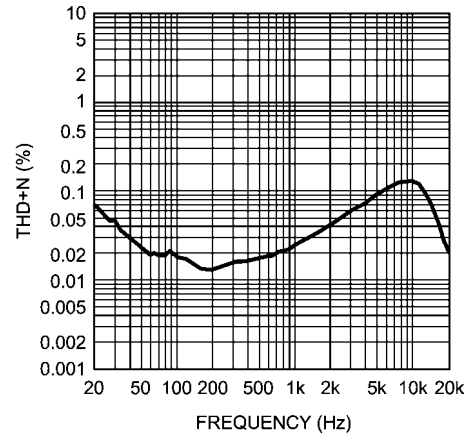

30121872

THD+N vs Frequency
 $R_L = 32\Omega$
 $P_{OUT} = 14mW, \text{Mode 4}$

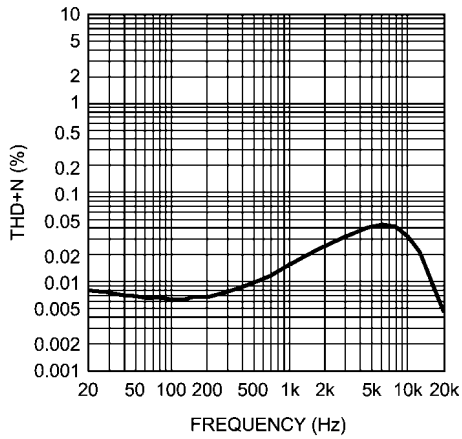

30121873

THD+N vs Frequency
 $R_L = 16\Omega$
 $P_{OUT} = 14mW, \text{Mode 4}$

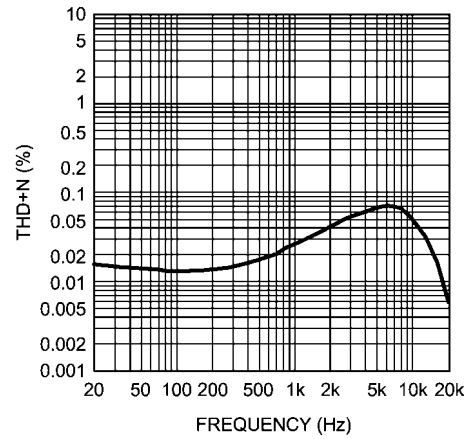

30121874

THD+N vs Frequency
 $R_L = 32\Omega$
 $P_{OUT} = 14mW, \text{Mode 6}$

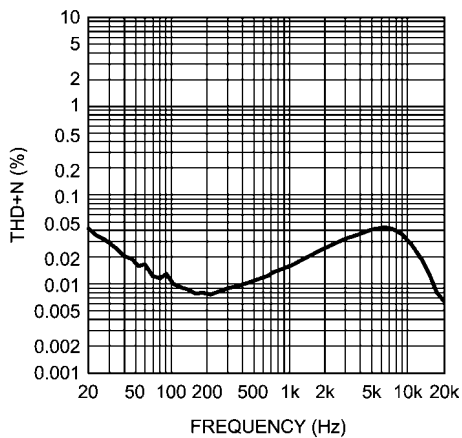

30121875

THD+N vs Output Power
 $V_{DD} = 3.6V, R_L = 15\mu H + 4\Omega + 15\mu H$
 $f = 1kHz, \text{Mode 2}$

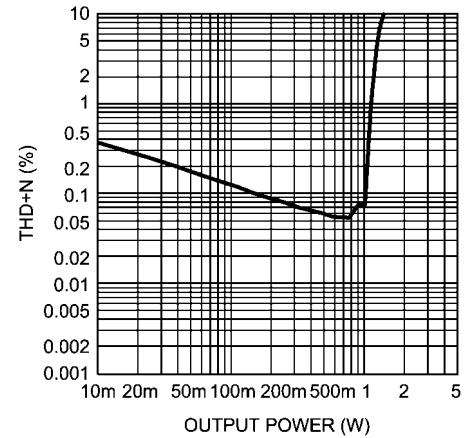

30121876

THD+N vs Output Power
 $V_{DD} = 3.6V$, $R_L = 15\mu H + 8\Omega + 15\mu H$
 $f = 1kHz$, Mode 2

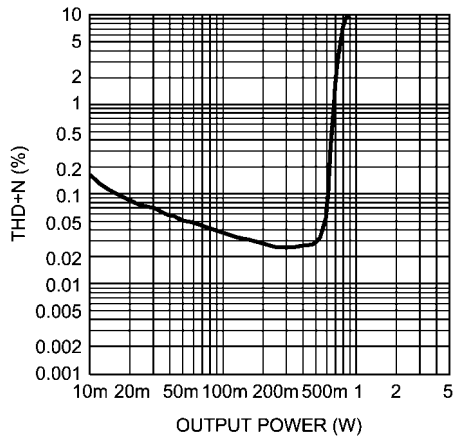

30121877

THD+N vs Output Power
 $V_{DD} = 3.6V$, $R_L = 15\mu H + 8\Omega + 15\mu H$
 $f = 1kHz$, Mode 3

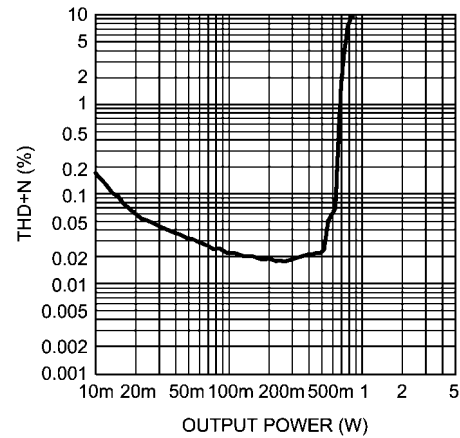

30121878

THD+N vs Output Power
 $V_{DD} = 3.6V$, $R_L = 15\mu H + 4\Omega + 15\mu H$
 $f = 1kHz$, Mode 3

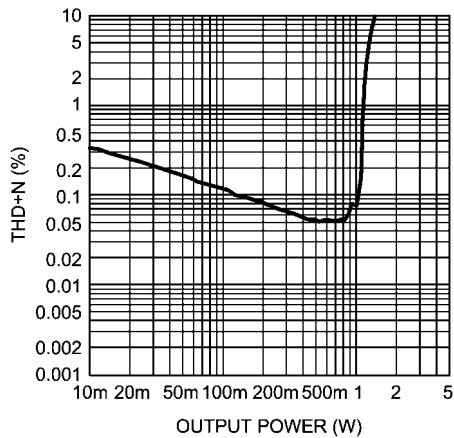

30121879

THD+N vs Output Power
 $V_{DD} = 5V$, $R_L = 15\mu H + 4\Omega + 15\mu H$
 $f = 1kHz$, Mode 2

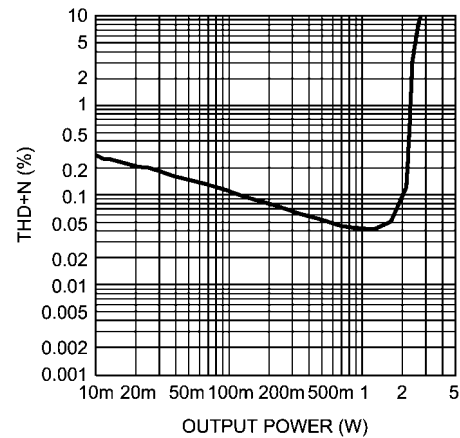

30121880

THD+N vs Output Power
 $V_{DD} = 5V$, $R_L = 15\mu H + 8\Omega + 15\mu H$
 $f = 1kHz$, Mode 2

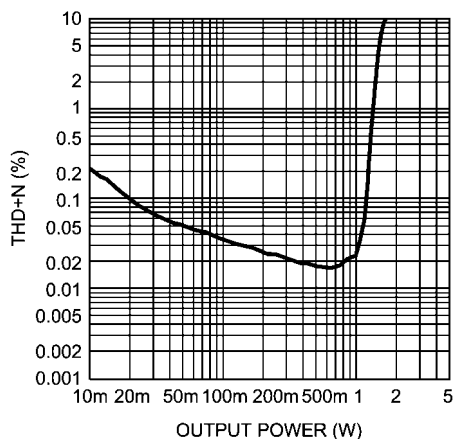

30121881

THD+N vs Output Power
 $V_{DD} = 5V$, $R_L = 15\mu H + 4\Omega + 15\mu H$
 $f = 1kHz$, Mode 3

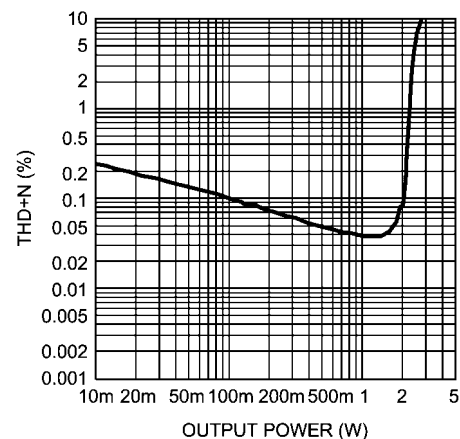

30121882

THD+N vs Output Power
 $V_{DD} = 5V, R_L = 15\mu H + 8\Omega + 15\mu H$
 $f = 1kHz, \text{Mode 3}$

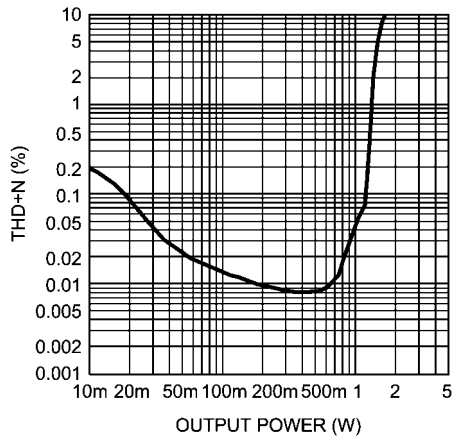

30121883

THD+N vs Output Power
 $R_L = 32\Omega, f = 1kHz, \text{Mode 4}$

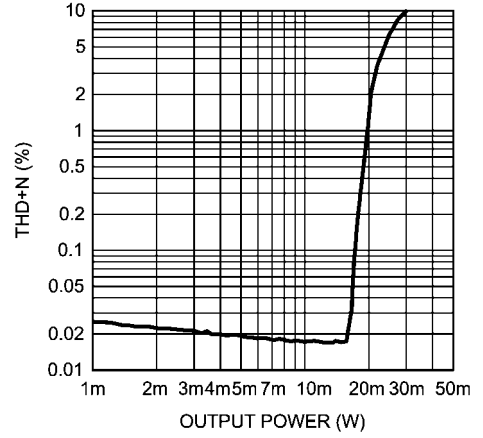

30121801

THD+N vs Output Power
 $R_L = 16\Omega, f = 1kHz, \text{Mode 4}$

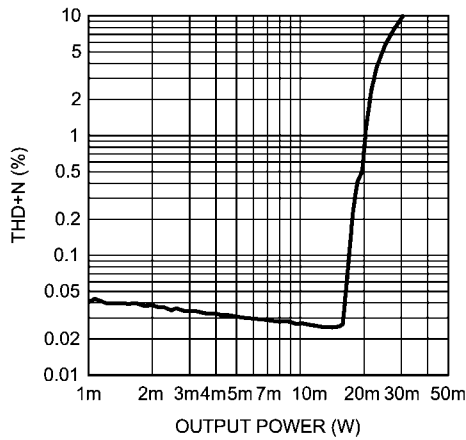

30121802

THD+N vs Output Power
 $R_L = 16\Omega, f = 1kHz, \text{Mode 6}$

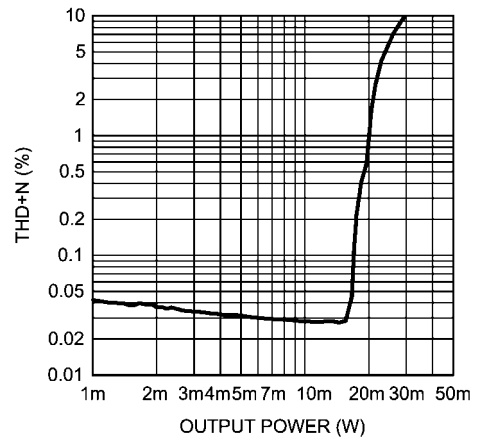

30121803

THD+N vs Output Power
 $R_L = 32\Omega, f = 1kHz, \text{Mode 6}$

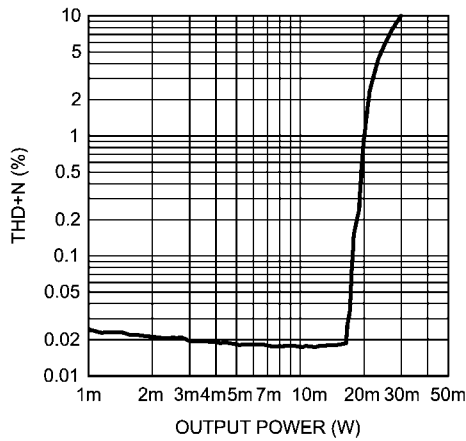

30121804

Power Dissipation vs Output Power
 $R_L = 15\mu H + 4\Omega + 15\mu H, f = 1kHz, V_{DD} = 3.6V$

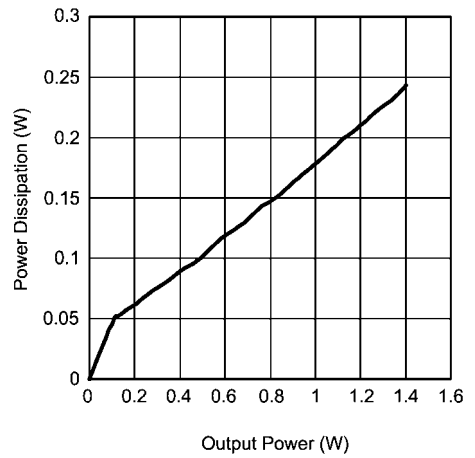

30121892

Power Dissipation vs Output Power
 $R_L = 15\mu\text{H}+4\Omega+15\mu\text{H}$, $f = 1\text{kHz}$, $V_{DD} = 5\text{V}$

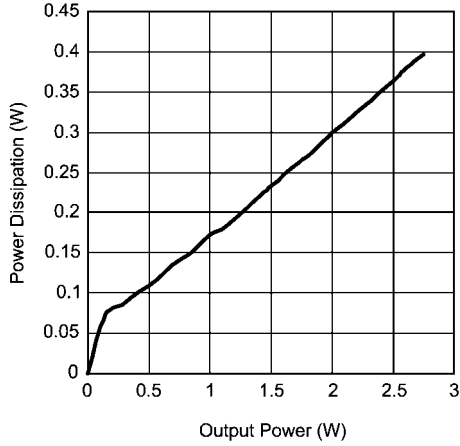

30121893

Power Dissipation vs Output Power
 $R_L = 15\mu\text{H}+8\Omega+15\mu\text{H}$, $f = 1\text{kHz}$, $V_{DD} = 3.6\text{V}$

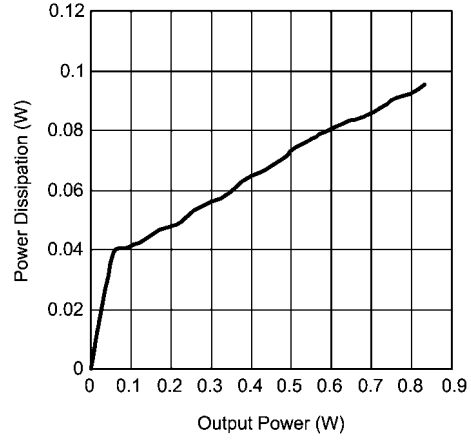

30121894

Power Dissipation vs Output Power
 $R_L = 15\mu\text{H}+8\Omega+15\mu\text{H}$, $f = 1\text{kHz}$, $V_{DD} = 5\text{V}$

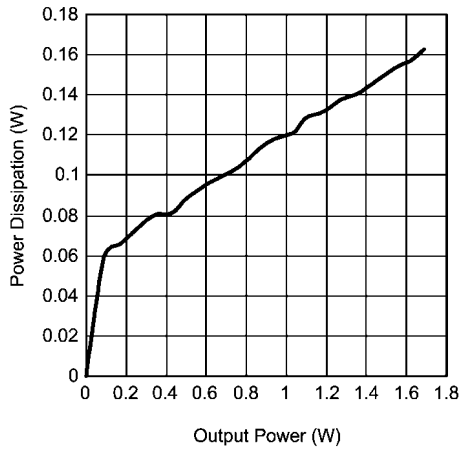

30121895

Power Dissipation vs Output Power
 $R_L = 16\Omega$, $f = 1\text{kHz}$, $V_{DD} = 1.8\text{V}$

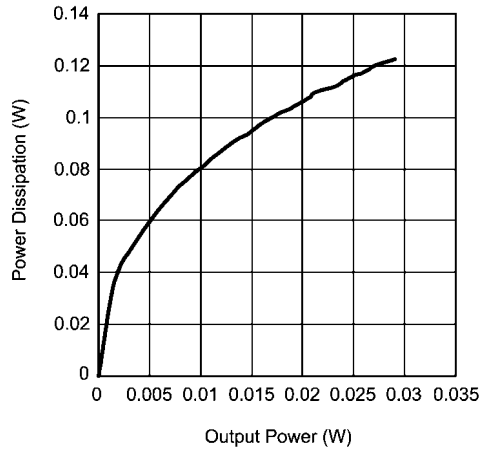

30121896

Power Dissipation vs Output Power
 $R_L = 32\Omega$, $f = 1\text{kHz}$, $V_{DD} = 1.8\text{V}$

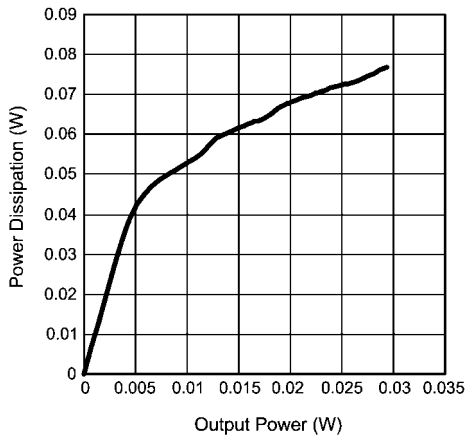

30121897

Efficiency vs Output Power
 $R_L = 15\mu\text{H}+4\Omega+15\mu\text{H}$, $f = 1\text{kHz}$, $V_{DD} = 3.6\text{V}$

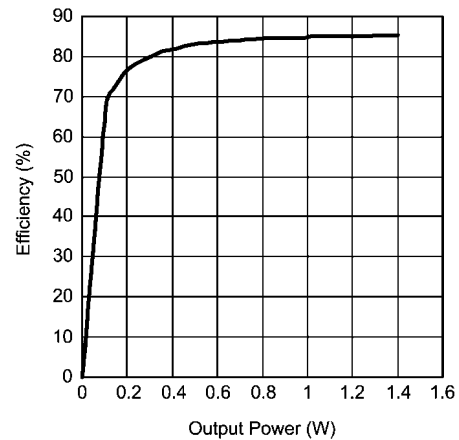

30121888

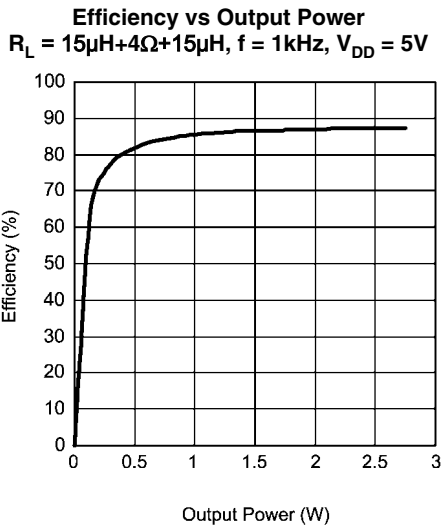

30121889

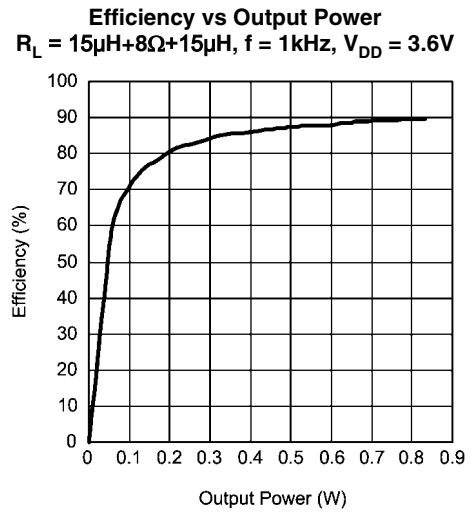

30121890

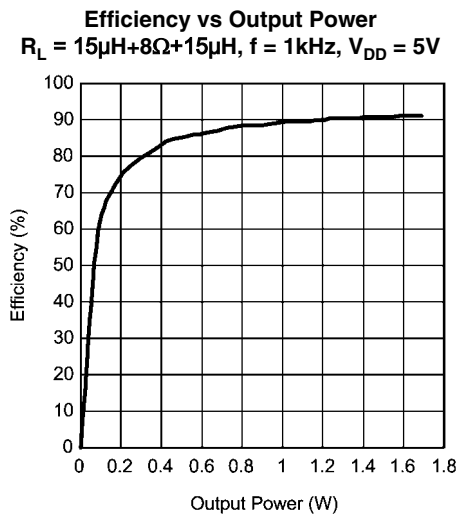

30121891

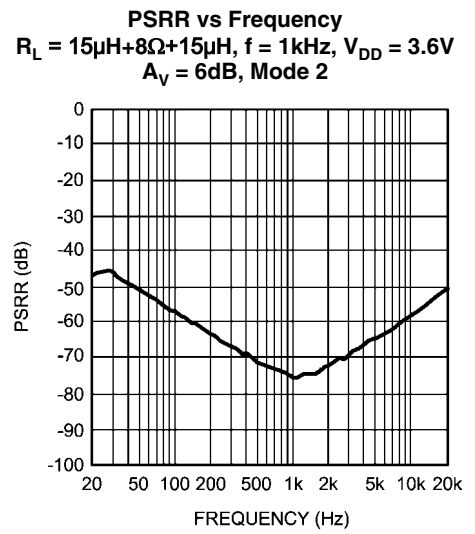

30121805

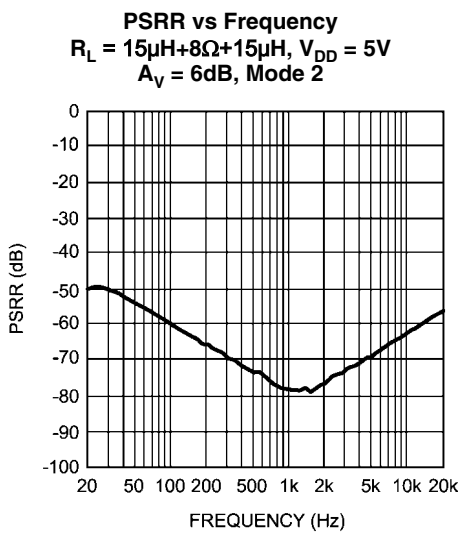

30121806

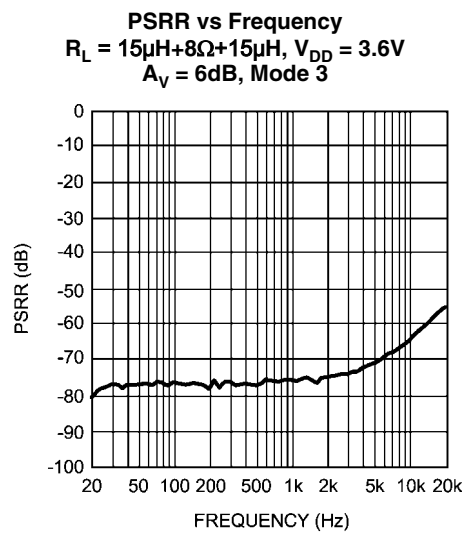

30121807

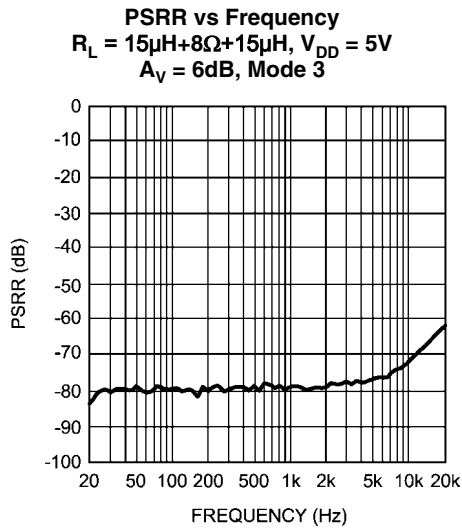

30121808

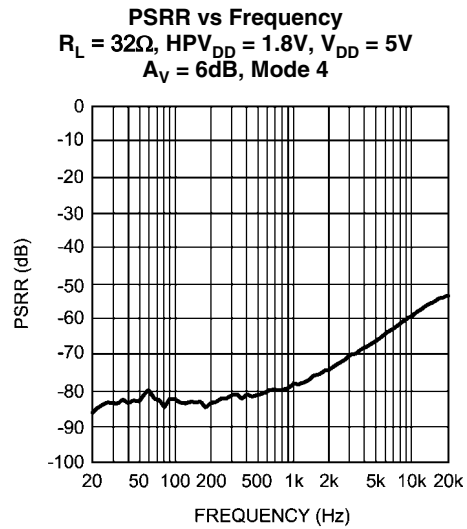

301218a2

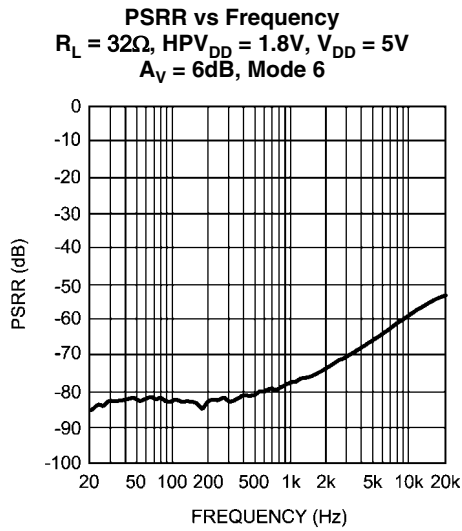

301218a3

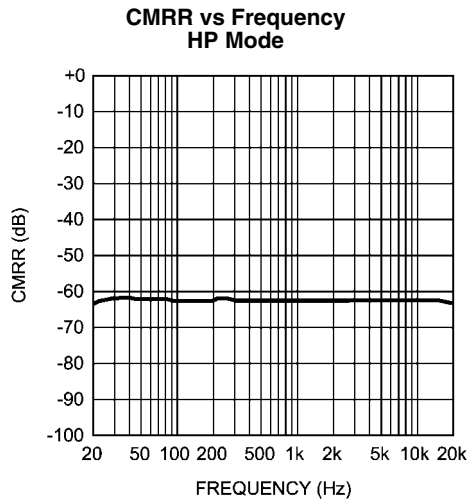

30121809

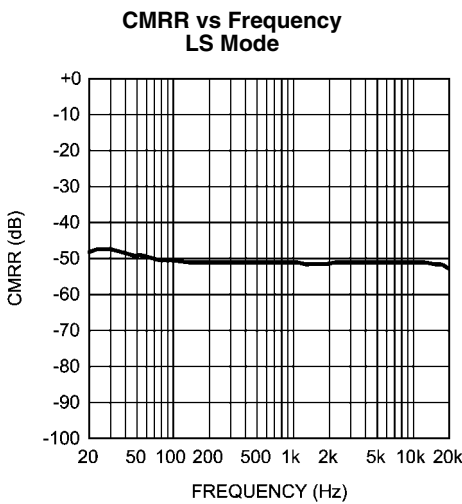

30121810

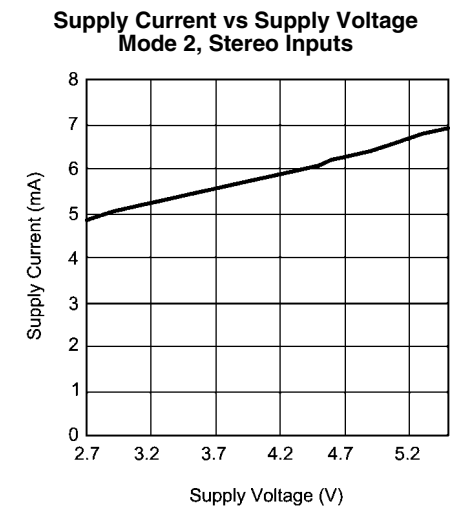

301218a6

Supply Current vs Supply Voltage
Mode 8, Stereo Inputs

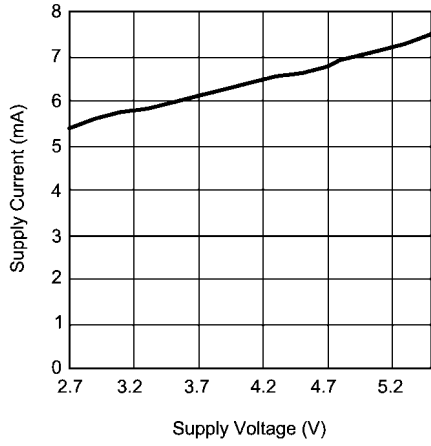

301218a8

Supply Current vs Supply Voltage
Mode 3, Mono Inputs

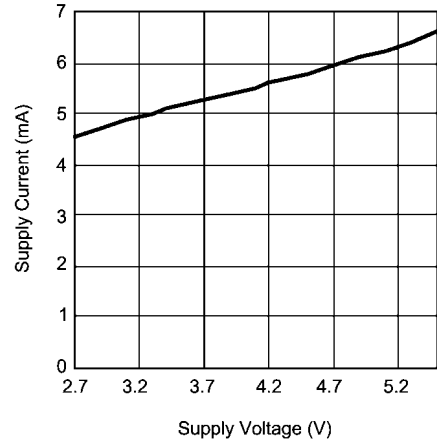

301218a7

System Control

I²C SIGNALS

In I²C mode the LM49251 pin SCL is used for the I²C clock SCL and the pin SDA is used for the I²C data signal SDA. Both of these signals need a pull-up resistor according to I²C specification. The 7-bits I²C slave address for LM49251 is 1111100.

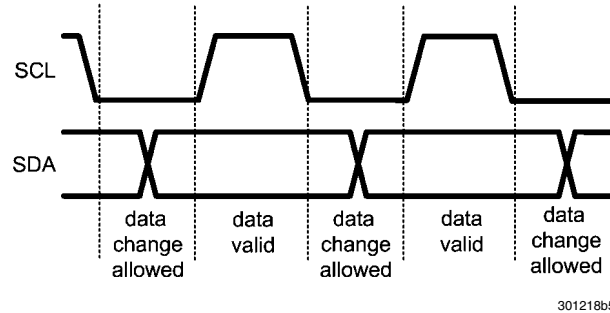

FIGURE 3. I²C Signals: Data Validity

I²C START AND STOP CONDITIONS

START and STOP bits classify the beginning and the end of the I²C session. START condition is defined as SDA signal transitioning from HIGH to LOW while SCL line is HIGH. STOP condition is defined as the SDA transitioning from LOW to HIGH while SCL is HIGH. The I²C master always generates

START and STOP bits. The I²C bus is considered to be busy after START condition and free after STOP condition. During data transmission, I²C master can generate repeated START conditions. First START and repeated START conditions are equivalent, function-wise.

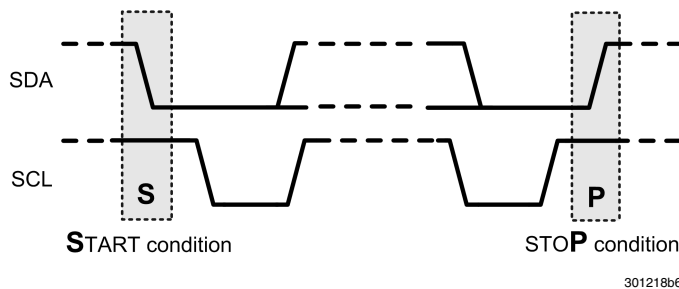

FIGURE 4. I²C Start and Stop Conditions

TRANSFERRING DATA

Every byte put on the SDA line must be eight bits long, with the most significant bit (MSB) being transferred first. Each byte of data has to be followed by an acknowledge bit. The acknowledge related clock pulse is generated by the master. The transmitter releases the SDA line (HIGH) during the acknowledge clock pulse. The receiver must pull down the SDA line during the 9th clock pulse, signifying an acknowledge. A receiver which has been addressed must generate an ac-

knowledge after each byte has been received. After the START condition, the I²C master sends a chip address. This address is seven bits long followed by an eight bit which is a data direction bit (R/W). The LM49251 address is 11111000. For the eighth bit, a "0" indicates a WRITE and a "1" indicates a READ. The second byte selects the register to which the data will be written. The third byte contains data to write to the selected register.

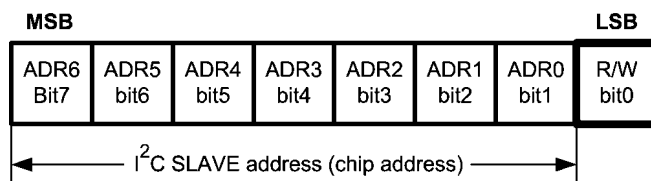
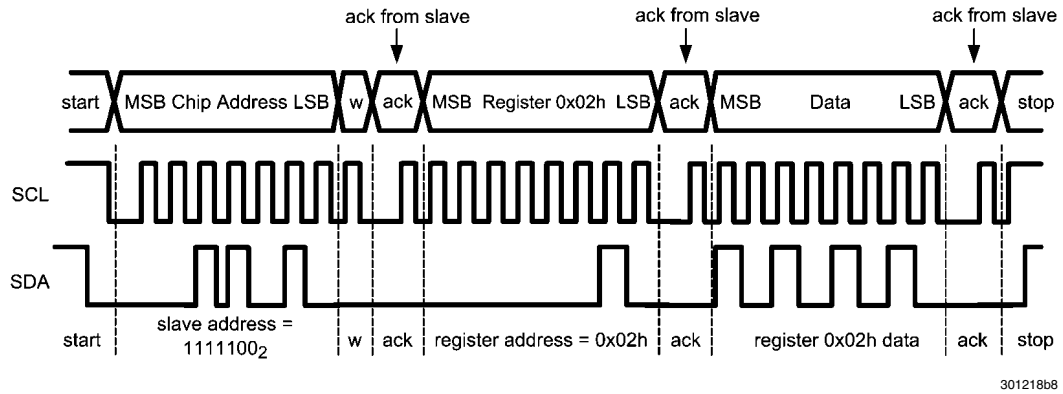
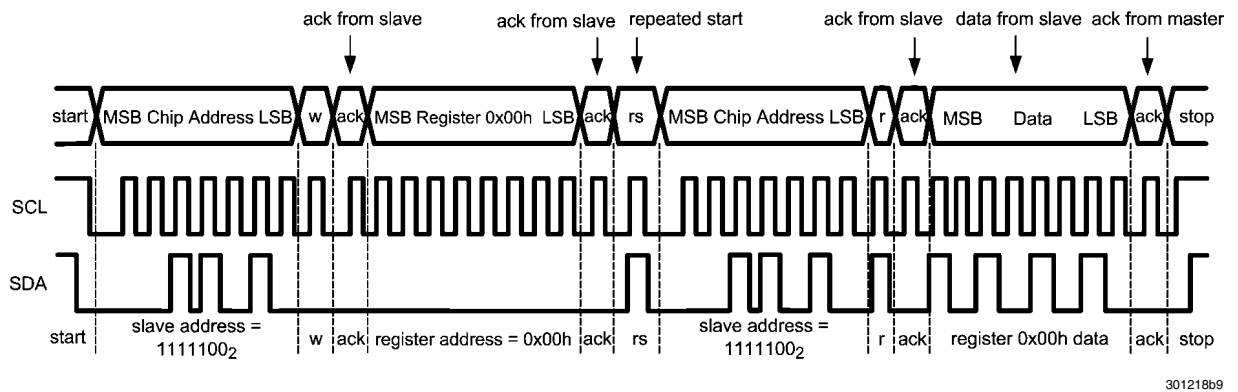

FIGURE 5. I²C Chip Address

FIGURE 6. Example I²C Write Cycle

When a READ function is to be accomplished, a WRITE function must precede the READ function, as shown in the Read Cycle waveform.



w = write (SDA = "0")
 r = read (SDA = "1")
 ack = acknowledge (SDA pulled down by slave)
 rs = repeated start

FIGURE 7. Example I²C Read Cycle

TABLE 2. Device Address

	B7	B6	B5	B4	B3	B2	B1	B0
Device Address	1	1	1	1	1	0	0	0

TABLE 3. I²C Control Registers

Register Name	B7	B6	B5	B4	B3	B2	B1	B0
SHUTDOWN CONTROL	0	0	0	1	GAMP_ON	HPR_SD	Class G_SD	\overline{SD}
MODE CONTROL	0	0	1	HP_ST	HP_M	SPK_L+R	SPK_ST	SPK_M
POWER LIMITER CONTROL	0	1	0	ATK1	ATK0	PLEV2	PLEV1	PLEV0
NO CLIP CONTROL	0	1	1	RLT1	RLT0	OCP2	OCP1	OCP0
GAIN CONTROL	1	0	0	LSGAINL	LSGAINR	HPGAIN2	HPGAIN1	HPGAIN0
MONO VOLUME CONTROL	1	0	1	MG4	MG3	MG2	MG1	MG0
STEREO VOLUME CONTROL	1	1	0	SG4	SG3	SG2	SG1	SG0
CLASS D CONTROL	1	1	1	0	0	0	ER_CNTRL	SS_EN
LS CONTROL	1	1	1	0	1	0	ST_SEL	LSR_SD
CLASS G CONTROL	1	1	1	1	0	0	TLEV1	TLEV2
OTHER CONTROL	1	1	1	1	1	I ² CV _{DD} SD	RAIL_SW	TURN_ON TIME

TABLE 4. Shutdown Control

BIT	NAME	VALUE	DESCRIPTION
B3	GAMP_ON		This disables the gain amplifiers that are not in use to minimize I _{DD} .
		0	Normal Operation
		1	Unused gain amplifiers disabled
B2	HPR_SD		This disables the right headphone output.
		0	Normal operation
		1	Right headphone amplifier disabled
B1	Class G_SD		This disables the Class G.
		0	Class G enabled
		1	Class G disabled
B0	SD		LM49251 Shutdown
		0	LM49251 Disabled
		1	LM49251 Enabled

TABLE 5. Output Mode Selection

HP (ST)	HP (M)	SPK (L +R)	SPK (ST)	SPK (M)	SPK(L)	SPK(R)	HP(L)	HP(R)	Datasheet
0	0	0	0	0	SD	SD	SD	SD	Mode 0
0	0	1	1	0	GST X (L + R)	GST X (L + R)	SD	SD	Mode 1
0	0	0	1	0	GST X L	GST X R	SD	SD	Mode 2
0	0	0	0	1	GM X M	GM X M	SD	SD	Mode 3
0	1	0	0	0	SD	SD	GM X M	GM X M	Mode 4
0	1	0	0	1	GM X M	GM X M	GM X M	GM X M	Mode 5
1	0	0	0	0	SD	SD	GSTX L	GST X R	Mode 6
1	0	1	1	0	GST X (L + R)	GST X (L + R)	GSTX L	GST X R	Mode 7
1	0	0	1	0	GST X L	GST X R	GSTX L	GST X R	Mode 8

TABLE 6. Voltage Limit Control Register

BIT	NAME	VALUE			DESCRIPTION
B4:B3	ATK1 ATK2	B4		B3	Sets Attack Time based on C _{SET} and R _{SET} t _{ATK} 1.3 x t _{ATK} 2 x t _{ATK} 2.7 x t _{ATK}
		0		0	
		0		1	
		1		0	
		1		1	
B2:B0	PLEV2 PLEV1 PLEV0	B2 B1 B0			Sets output power limit level
		0 0 0			Voltage Limit disabled
		0 0 1			V _{TH(VLIM)} = 3.9V _{P-P}
		0 1 0			V _{TH(VLIM)} = 4.7V _{P-P}
		0 1 1			V _{TH(VLIM)} = 5.4V _{P-P}
		1 0 0			V _{TH(VLIM)} = 6.2V _{P-P}
		1 0 1			V _{TH(VLIM)} = 7.0V _{P-P}
		1 1 0			V _{TH(VLIM)} = 7.8V _{P-P}
		1 1 1			Voltage Limit disabled

TABLE 7. No Clip Control Register

BIT	NAME	VALUE			DESCRIPTION
		B2	B1	B0	
B2:B0	OCP2 OCP1 OCP0				This sets the output clip limit level
		0	0	0	NO_CLIP = disabled, OUTPUT_CLIP = disabled
		0	0	1	Test Mode
		0	1	0	NO_CLIP = enabled, OUTPUT_CLIP = disabled
		0	1	1	low
		1	0	0	medium
		1	0	1	medium high
		1	1	0	high
		1	1	1	maximum
B4:B3	RLT1 RTL0	B1	B0		This sets the release time of the automatic limiter control circuit.
		0	0		1s
		0	1		0.8s
		1	0		0.65s
		1	1		0.4s

TABLE 8. Gain Control Register

BIT	NAME	VALUE			DESCRIPTION
		B2	B1	B0	
B4	LSGAINL	0			6dB Loudspeaker gain
		1			12dB Loudspeaker gain
B3	LSGAINR	0			6dB Loudspeaker gain
		1			12dB Loudspeaker gain
B2:B0	HPGAIN2 (B2) HPGAIN1 (B1) HPGAIN0 (B0)	B2	B1	B0	Headphone Gain
		0	0	0	0dB
		0	0	1	-1.5dB
		0	1	0	-3dB
		0	1	1	-6dB
		1	0	0	-9dB
		1	0	1	-12dB
		1	1	0	-15dB
1	1	1	-18dB		

General Amplifier Function

TABLE 9. Volume Control Table

VOLUME STEP	_G4	_G3	_G2	_G1	_G0	GAIN (dB)
1	0	0	0	0	0	-80
2	0	0	0	0	1	-46.5
3	0	0	0	1	0	-40.5
4	0	0	0	1	1	-34.5
5	0	0	1	0	0	-30
6	0	0	1	0	1	-27
7	0	0	1	1	0	-24
8	0	0	1	1	1	-21
9	0	1	0	0	0	-18
10	0	1	0	0	1	-15
11	0	1	0	1	0	-13.5
12	0	1	0	1	1	-12
13	0	1	1	0	0	-10.5
14	0	1	1	0	1	-9
15	0	1	1	1	0	-7.5
16	0	1	1	1	1	-6
17	1	0	0	0	0	-4.5
18	1	0	0	0	1	-3
19	1	0	0	1	0	1.5
20	1	0	0	1	1	0
21	1	0	1	0	0	1.5
22	1	0	1	0	1	3
23	1	0	1	1	0	4.5
24	1	0	1	1	1	6
25	1	1	0	0	0	7.5
26	1	1	0	0	1	9
27	1	1	0	1	0	10.5
28	1	1	0	1	1	12
29	1	1	1	0	0	X
30	1	1	1	0	1	X
31	1	1	1	1	0	X
32	1	1	1	1	1	X

TABLE 10. Class D Control

BIT	NAME	VALUE	DESCRIPTION
B1	ER_CNTRL	This enables edge rate control.	
		0	Edge Rate Control Disabled
		1	Edge Rate Control Enabled
B0	SS_EN	This enables Spread Spectrum.	
		0	Spread Spectrum Disabled
		1	Spread Spectrum Enabled

TABLE 11. Loudspeaker (LS) Control

BIT	NAME	VALUE	DESCRIPTION
B1	ST_SEL	This allows selection between two Stereo Inputs.	
		0	LIN1/RIN1
		1	LIN2/RIN2
B0	LSR_SD	This disables the Left Loudspeaker.	
		0	Left Loudspeaker enabled
		1	Left Loudspeaker disabled

TABLE 12. Class G Control

BIT	NAME	VALUE		DESCRIPTION
		B1	B0	
B1:B0	TLEV1 TLEV0	This sets the Trip Level.		
		0	0	High (default)
		0	1	High-Medium
		1	0	Low-Medium
		1	1	Low

TABLE 13. Other Control

BIT	NAME	VALUE	DESCRIPTION
B1	RAIL_SW	This switches between two HP voltage rails*	
		0	High Rail
		1	Low Rail
B0	TURN_ON_TIME	This allows fast turn on time	
		0	Normal Turn-On Time
		1	Fast Turn-On Time

*This option is only available when the Class G is disabled.

Application Information

DIFFERENTIAL AMPLIFIER EXPLANATION

The LM49251 features a differential input stage, which offers improved noise rejection compared to a single-ended input amplifier. Because a differential input amplifier amplifies the difference between the two input signals, any component common to both signals is cancelled. An additional benefit of the differential input structure is the possible elimination of the DC input blocking capacitors. Since the DC component is common to both inputs, and thus cancelled by the amplifier, the LM49251 can be used without input coupling capacitors when configured with a differential input signal.

INPUT MIXER/MULTIPLEXER

The LM49251 includes a comprehensive mixer multiplexer controlled through the I²C interface. The mixer/multiplexer allows any input combination to appear on any output of LM49251. *Table 5* (MODE CONTROL) shows how the input signals are routed together for each possible input selection.

SHUTDOWN FUNCTION

The LM49251 features the following shutdown controls: Bit B4 (GAMP_SD) of the SHUTDOWN CONTROL register controls the gain amplifiers. When GAMP_SD = 1, it disables the gain amplifiers that are not in use. For example, in Modes 1, 4 and 5, the Mono inputs are in use, so the Left and Right input gain amplifiers are disabled, causing the I_{DD} to be minimized. Bit B0 (PWR_ON) of the SHUTDOWN CONTROL register is the global shutdown control for the entire device. Set PWR_ON = 0 for normal operation. PWR_ON = 1 overrides any other shutdown control bit.

CLASS D AMPLIFIER

The LM49251 features a mono class D audio power amplifier with a filterless modulation scheme that reduces external component count, conserving board space and reducing system cost. With no signal applied, the outputs (LSOUT+ and LSOUT-) switch between VDD and GND with 50% duty cycle, in phase, causing the two outputs to cancel. This cancellation results in no net voltage across the speaker, thus there is no current to the load in the idle state.

With an input signal applied, the duty cycle (pulse width) of the class D output changes. For increasing output voltage, the duty cycle of LSOUT+ increases, while the duty cycle of LSOUT- decreases. For decreasing output voltages, the converse occurs. The difference between the two pulse widths yields the differential output voltage.

ENHANCED EMISSIONS SUPPRESSION (E²S)

The LM49251 class D amplifier features National's patent-pending E²S system that reduces EMI, while maintaining high quality audio reproduction and efficiency. The E²S system features selectable spread spectrum and advanced edge rate control (ERC). The LM49251 class D ERC greatly reduces the high frequency components of the output square waves by controlling the output rise and fall times, slowing the transitions to reduce RF emissions, while maximizing THD+N and efficiency performance.

FIXED FREQUENCY

The LM49251 class D amplifier features two modulation schemes, a fixed frequency mode and a spread spectrum mode. Select the fixed frequency mode by setting bit B0

(SS_EN) of the SS Control register to 0. In fixed frequency mode, the loudspeaker outputs switch at a constant 300kHz. The output spectrum consists of the 300kHz fundamental and its associated harmonics.

SPREAD SPECTRUM

The selectable spread spectrum mode minimizes the need for output filters, ferrite beads or chokes. In spread spectrum mode, the switching frequency varies randomly by 30% about a 300kHz center frequency, reducing the wideband spectral content, improving EMI emission radiated by the speaker and associated cables and traces. Where a fixed frequency class D exhibits large amounts of spectral energy at multiples of the switching frequency, the spread spectrum architecture spreads that energy over a larger bandwidth. The cycle-to-cycle variation of the switching period does not affect the audio reproduction, efficiency, or PSRR. Set bit B0 (SS_EN) of the SS Control register to 1 to enable spread spectrum mode.

GROUND REFERENCED HEADPHONE AMPLIFIER

The LM49251 features a low noise inverting charge pump that generates an internal negative supply voltage. This allows the headphone outputs to be biased about GND instead of a nominal DC voltage, like traditional headphone amplifiers. Because there is no DC component, the large DC blocking capacitors (typically 220μF) at the headphone outputs are not necessary. The coupling capacitors are replaced by two small ceramic charge pump capacitors, saving board space and cost. Eliminating the output coupling capacitors also improves low frequency response. In traditional headphone amplifiers, the headphone impedance and the output capacitor form a high-pass filter that not only blocks the DC component of the output, but also attenuates low frequencies, impacting the bass response. Because the LM49251 does not require the output coupling capacitors, the low frequency response of the device is not degraded by external components. In addition to eliminating the output coupling capacitors, the ground referenced output nearly doubles the available dynamic range of the LM49251 headphone amplifiers when compared to a traditional headphone amplifier operating from the same supply voltage.

CLASS G OPERATION

The LM49251 features a ground referenced class G headphone amplifier for increased efficiency and decreased power dissipation. This particular architecture creates a ground-referenced output with dynamic supply rails for optimum efficiency. Music and voice signals have a high peak-to-mean ratio with the majority of the signal content at low levels, class G amplifiers take advantage of this behavior. Class G amplifiers have multiple voltage supplies to decrease power dissipation. The LM49251 has two discrete supply rails: ±0.9V and ±1.8V. The device switches from ±0.9V to ±1.8V when the output signal reaches the selectable threshold level to switch to the higher voltage rails. When the output falls below the required voltage for a set period of time, it will switch back to the lower rail until the next time the threshold is reached. The threshold level has 4 selectable levels that can be set through the Class G Control I²C control register <B1:B2>. With this topology power dissipation is reduced for typical music or voice sources. *Figure 8* below shows how a music output may look.

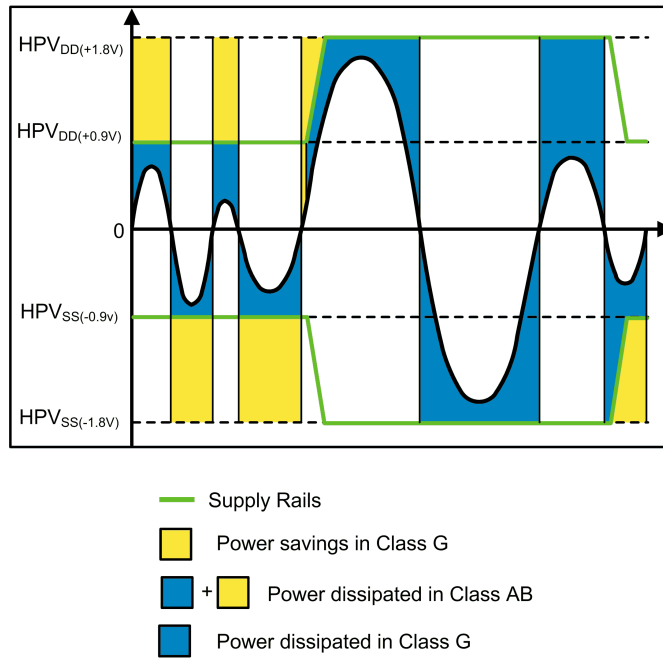

301218c1

FIGURE 8. Class G Operation

Disabling the Class G

The Class G feature can be disabled via I²C Shutdown Control Register B1. When the Class G is disabled the headphone supply rails are selectable. In the Other Control register B1 =

0 sets the headphone supply rails at $\pm 1.8\text{V}$ (high) and B1 = 1 sets the supply to $\pm 0.9\text{V}$ (low). *Figure 9* below shows a curve of THD+N vs Output Power for the two supply rails.

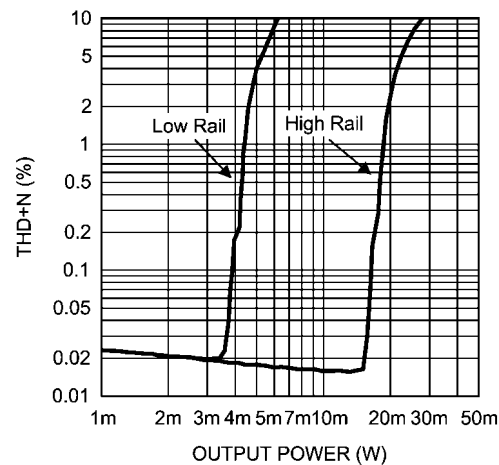

30121824

FIGURE 9. Class G Disabled (Low/High Supply Rails)

AUTOMATIC LIMITER CONTROL (ALC)

When enabled, the ALC continuously monitors and adjusts the gain of the loudspeaker amplifier signal path if necessary. The ALC serves two functions: voltage limiter/speaker protection and output clip prevention (No-Clip) with three clip controls levels. The voltage limiter/speaker protection prevents an output overload condition by maintaining the loud-

speaker output signal below a preset amplitude (See voltage Limiter section). The No Clip feature monitors the output signal and maintains audio quality by preventing the loudspeaker output from exceeding the amplifier's headroom (see No Clip/ Output Clip Control section). The voltage limiter thresholds, clip control levels, attack and release times are configured through the I²C interface.

VOLTAGE LIMITER

The voltage limiter function of the ALC monitors and prevents the audio signal from exceeding the voltage limit threshold. The voltage limit threshold ($V_{TH(VLIM)}$) is set by bits B2:B0 in the "Voltage Limit Threshold Register" (see [Table 6](#)). Although the ALC reduces the gain of the speaker path to

maintain the audio signal below the voltage limit threshold, it is still possible to overdrive the speaker output in which case loudspeaker output will exceed the voltage limit threshold and cause clipping on the output, and speaker damage is possible. Please see the ALC headroom section for further details.

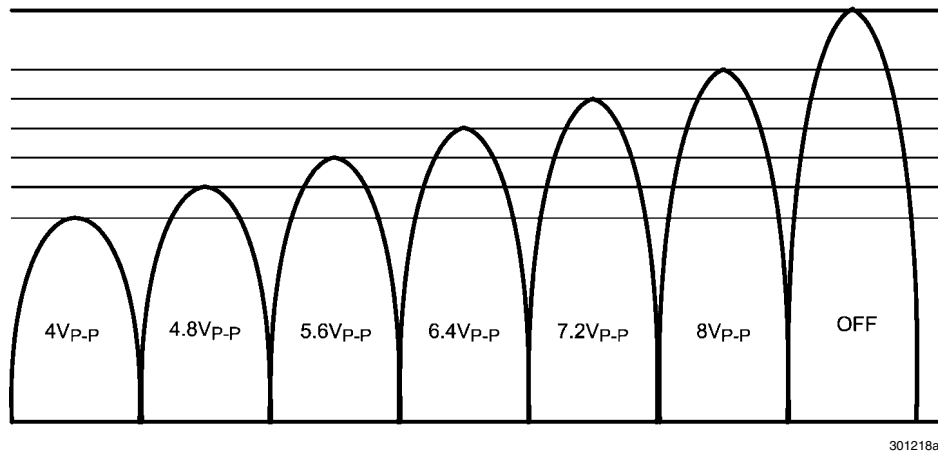

FIGURE 10. Voltage Limit Output Level

NO CLIP/OUTPUT CLIP CONTROL

The LM49251 No Clip circuitry detects when the loudspeaker output is near clipping and reduces the signal gain to prevent output clipping and preserve audio quality (Figure 6). Al-

though the ALC reduces the gain of the speaker path to prevent output clipping, it is still possible to overdrive the speaker output. Please see the ALC headroom section for further details.

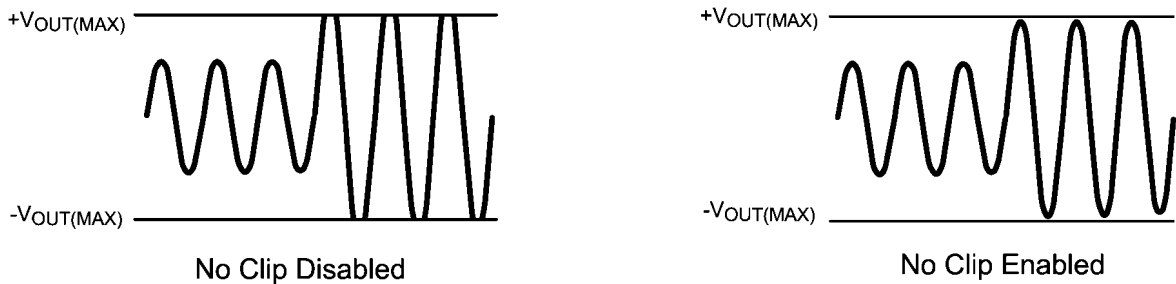
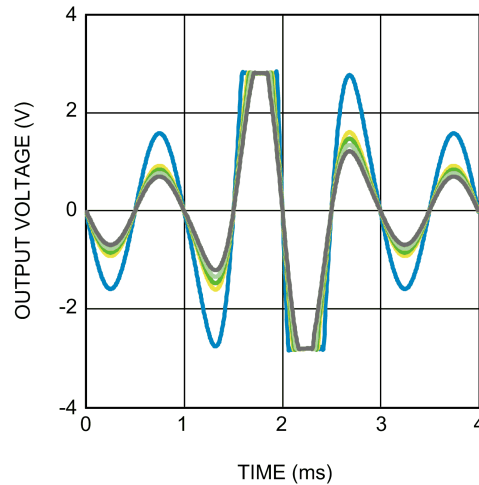

FIGURE 11. No Clip Function

The LM49251 also features an output clip control that allows a certain amount of clipping at the output in order to increase the loudspeaker output power. The clip level is set by B2:B0 in the No Clip Control Register (see [Table 7](#)). The clip control works by allowing the output to enter clipping before the ALC turns on and maintains the output level. The clip control has

three levels: low, medium, and high. The low and max clip level control settings give the lowest distortion and highest distortion respectively on the output (see [Figure 12](#)). The actual output level of the device will depend upon the supply voltage, and the output power will depend upon the load impedance.



301218b1

FIGURE 12. Clip Control Levels
 $V_{DD} = 3.3V$, $V_{IN} = 8V_{PP}$ Shaped Burst, 1kHz
 Blue = No Clip Disabled, Gray = Low, Light Green = Medium
 Green = High, Yellow = Max

ALC HEADROOM

When either voltage limiter or no clip is enabled, it is still possible to drive LM49251 into clipping by over driving the input volume stage of the signal path beyond its output dynamic range. In this case, clipping occurs at the input volume stage, and although ALC is active, the gain reduction will have no effect on the output clipping. The maximum input that can safely pass through the input volume stage can be calculated by following formula:

$$V_{IN} \leq \frac{V_{DD}}{A_v \text{ (volume gain)}} \quad (1)$$

So in the case of 0 dB volume gain, audio input has to be less than V_{DD} for both voltage limiter or No clip settings.

When voltage limiter is enabled, ALC can reach its max attenuation for lower voltage limit levels as shown in Figure 13. Typically, after the ALC started working, with 6 dB of audio input change ALC is well within its regulation. Voltage limiter Input headroom can be increased by switching to the LS_GAIN to 18dB in the Gain Control Register (see Table 8).

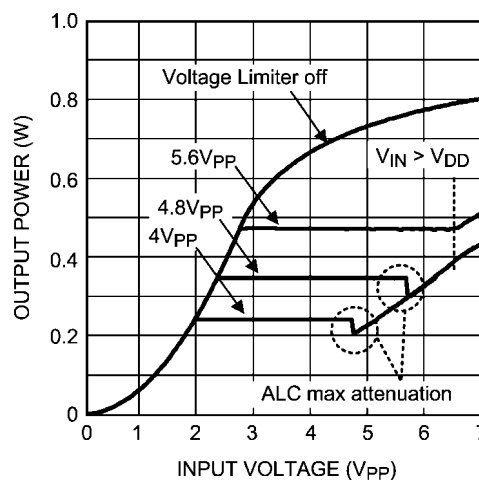

301218b2

FIGURE 13. Voltage Limiter Function
 $V_{DD} = 3.3V$, $R_L = 15\mu H + 8\Omega + 15\mu H$
 $f_{IN} = 1kHz$, LS_GAIN = 0

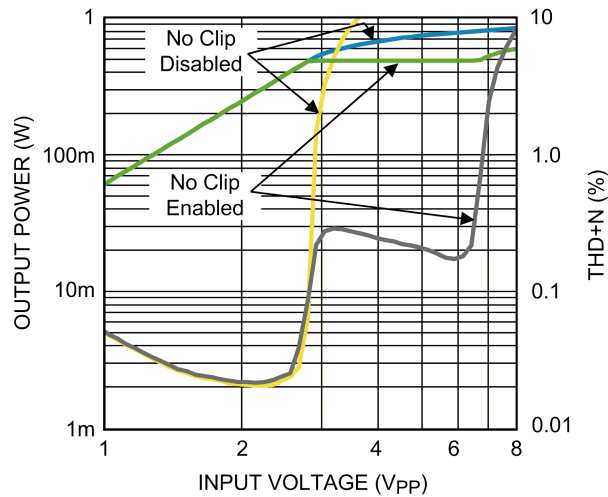

30121863

FIGURE 14. No Clip Function
 $V_{DD} = 3.3V$, $R_L = 15\mu H + 8\Omega + 15\mu H$
 $f_{IN} = 1kHz$, $LS_GAIN = 0$
Blue, Green = Output Power vs Input Voltage
Gray, Yellow = THD+N vs Input Voltage

When No Clip is enabled, class D speaker output reduces when it's about to enter clipping region and power stay constant as long as V_{IN} is less than V_{DD} for 0 dB volume gain (see figure 9). For example, in the case of $V_{DD} = 3.3V$, there is a 6 dB of headroom for the change in input. Please see the ALC typical performance curves for additional plots relating to different supply voltages and LS_GAIN settings for specific application parameters.

ATTACK TIME

Attack time (t_{ATK}) is the time it takes for the gain to be reduced by 6dB ($LS_GAIN=0$) once the audio signal exceeds the ALC threshold. Fast attack times allow the ALC to react quickly and prevent transients such as symbol crashes from being distorted. However, fast attack times can lead to volume pumping, where the gain reduction and release becomes noticeable, as the ALC cycles quickly. Slower attack times cause the ALC to ignore the fast transients, and instead act upon longer, louder passages. Selecting an attack time that is too slow can lead to increased distortion in the case of the No Clip function, and possible output overload conditions in the case of the Voltage limiter. The attack time is set by a combination of the value of C_{SET} and the attack time coefficient as given by equation (2):

$$t_{ATK} = 20k\Omega C_{SET} / \alpha_{ATK} \quad (s) \quad (2)$$

Where α_{ATK} is the attack time coefficient (Table 14) set by bits B4:B3 in the Voltage Limit Control Register (see Table 6). The attack time coefficient allows the user to set a nominal attack time. The internal 20k Ω resistor is subject to temperature change, and it has tolerance between -11% to +20%.

TABLE 14. Attack Time Coefficient

B4	B3	α_{ATK}
0	0	2.667
0	1	2
1	0	1.333
1	1	1

RELEASE TIME

Release time (t_{RL}) is the time it takes for the gain to return from 6dB ($LS_GAIN=0$) to its normal level once the audio signal returns below the ALC threshold. A fast release time allows the ALC to react quickly to transients, preserving the original dynamics of the audio source. However, similar to a fast attack time, a fast release time contributes to volume pumping. A slow release time reduces the effect of volume pumping. The release time is set by a combination of the value of C_{SET} and release time coefficient as given by equation (3):

$$t_{RL} = 20M\Omega C_{SET} / \alpha_{RL} \quad (s) \quad (3)$$

where α_{RL} is the release time coefficient (Table 14) set by bits B4:B3 in the No Clip Control Register. The release time coefficient allows the user to set a nominal release time. The internal 20M Ω is subject to temperature change, and it has tolerance between -11% to +20%.

TABLE 15. Release Time Coefficient

B4	B3	α_{RL}
0	0	2
0	1	2.5
1	0	3
1	1	5

A-WEIGHTED FILTER

The human ear is sensitive for acoustic signals within a frequency range from about 20Hz to 20kHz. Within this range the sensitivity of the human ear is not equal for each frequency. To approach the hearing response, weighting filters are introduced. One of those filters is the A-weighted filter.

The A-weighted filter is used in signal to noise measurements, where the wanted audio signal is compared to device noise and distortion.

The use of this filter improves the correlation of the measured values to the way these ratios are perceived by the human ear.

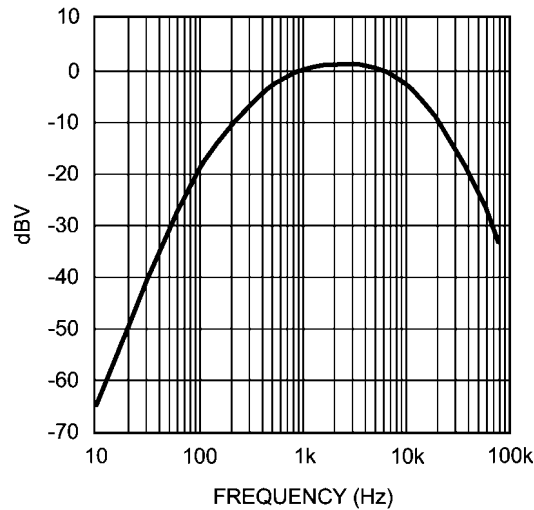

301218b4

FIGURE 15. A-Weighted Filter

PROPER SELECTION OF EXTERNAL COMPONENTS

ALC Timing (C_{SET}) Capacitor Selection

The recommended range value of C_{SET} is between $.01\mu\text{F}$ to $1\mu\text{F}$. Lowering the value below $.01\mu\text{F}$ can increase the attack time but LM49251 ALC ability to regulate its output can be disrupted and approaches the hard limiter circuit. This in turn increases the THD+N and audio quality will be severely affected.

Charge Pump Capacitor Selection

Use low ESR ceramic capacitors (less than $100\text{m}\Omega$) for optimum performance.

Charge Pump Flying Capacitor (C_1)

The flying capacitor (C_1), see [Figure 2](#), affects the load regulation and output impedance of the charge pump. A C_1 value that is too low results in a loss of current drive, leading to a loss of amplifier headroom. A higher valued C_1 improves load regulation and lowers charge pump output impedance to an extent. Above $2.2\mu\text{F}$, the $R_{DS(ON)}$ of the charge pump switches and the ESR of C_1 and CPV_{SS} dominate the output impedance. A lower value capacitor can be used in systems with low maximum output power requirements.

Charge Pump Hold Capacitor (CPV_{SS})

The value and ESR of the hold capacitor (CPV_{SS}) directly affects the ripple on CPV_{SS} (see [Figure 2](#)). Increasing the value

of CPV_{SS} reduces output ripple. Decreasing the ESR of CPV_{SS} reduces both output ripple and charge pump output impedance. A lower value capacitor can be used in systems with low maximum output power requirements.

Input Capacitor Selection

Input capacitors may be required for some applications, or when the audio source is single-ended. Input capacitors block the DC component of the audio signal, eliminating any conflict between the DC component of the audio source and the bias voltage of the LM49251. The input capacitors create a high-pass filter with the input resistors R_{IN} . The -3dB point of the high-pass filter is found using Equation (4) below.

$$f = 1 / 2\pi R_{IN} C_{IN} \quad (\text{Hz}) \quad (4)$$

Where the value of R_{IN} is given in the Electrical Characteristics Table.

High-pass filtering the audio signal helps protect the speakers. When the LM49251 is using a single-ended source, power supply noise on the ground is seen as an input signal. Setting the high-pass filter point above the power supply noise frequencies, 217Hz in a GSM phone, for example, filters out the noise such that it is not amplified and heard on the output. Capacitors with a tolerance of 10% or better are recommended for impedance matching and improved CMRR and PSRR.

Demo Board User Guide

Quick Start Guide:

1. Connect a shunt across pin 1 and pin 2 of JUI to provide 3.3V to I²CV_{DD}.
2. Connect a shunt across JU3 to provide 1.8V to V_{DD}HP from on board regulator.
3. Connect a 4Ω or 8Ω speaker across LSOUTL (left loudspeaker output) and LSOUTR (right loudspeaker output).
4. Connect stereo headphones to the headphone jack J1.
5. Connect a 3.6V power supply to the V_{DD} pin of J3 and the ground source to the GND pin.
6. Apply audio input signal to any of the stereo (IN1/IN2) or mono (MONO_IN) inputs.

7. Turn on power supply.
8. Connect the mini USB cable to J29 and the other end of the cable to a PC.
9. Open the LM49251 I²C control software.
10. Verify that the device has been acknowledged by looking at bottom left corner of GUI (see [Figure 16](#) and [Figure 17](#)).
11. On GUI:
 - a. Set POWER: on
 - b. Set MODE SELECT to desired position (see [Table 16](#)).
 - c. Set all VOLUME CONTROL to 0dB by clicking on Set 0dB button.

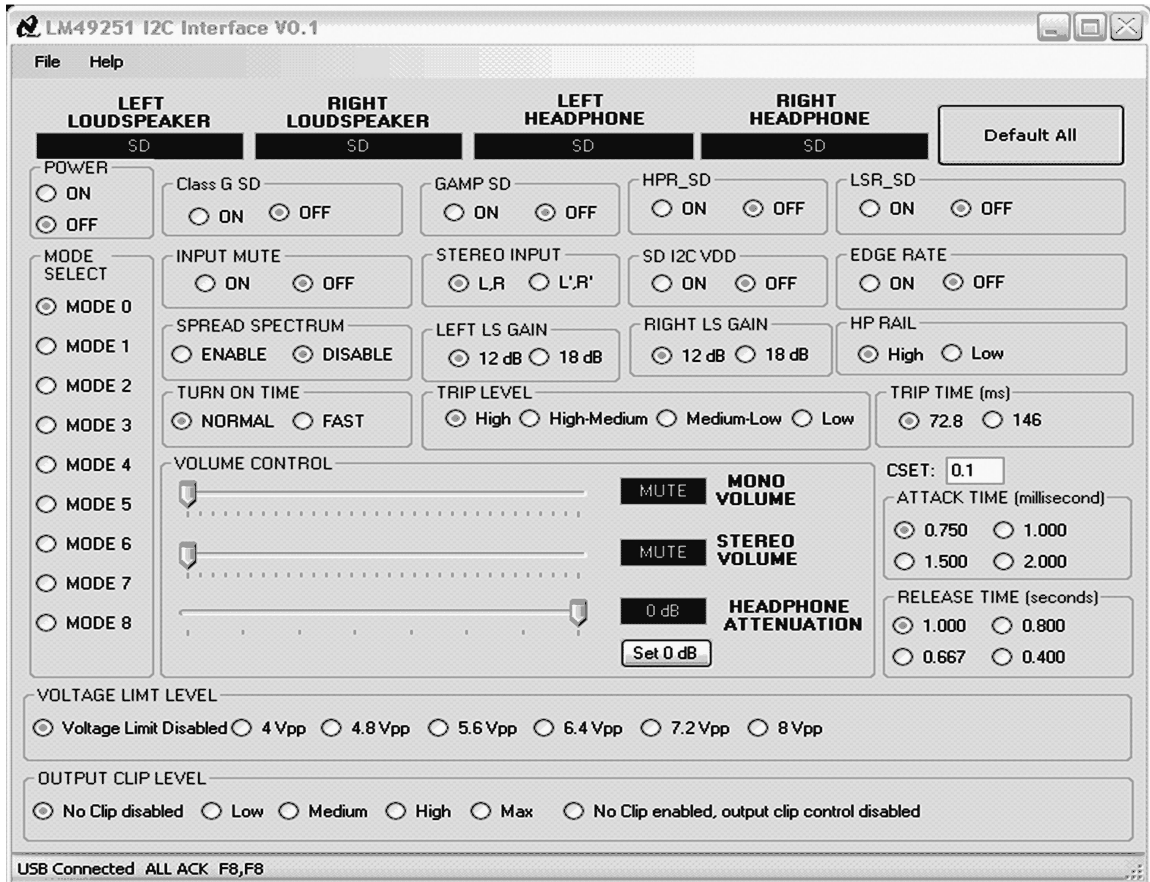

30121822

FIGURE 16. Software Graphic user Interface (GUI)

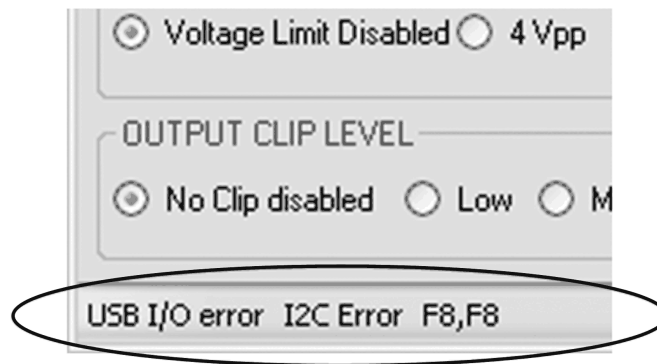

30121823

FIGURE 17. Error Message displayed on GUI if device is NOT acknowledged (I²C Error) or if there is an USB error (USB I/O error)

TABLE 16. Mode Table

SPK(L)	SPK(R)	HP(L)	HP(R)	Datasheet
SD	SD	SD	SD	Mode 0
G _{ST} X (L + R)	G _{ST} X (L + R)	SD	SD	Mode 1
G _{ST} X L	G _{ST} X R	SD	SD	Mode 2
G _M X M	G _M X M	SD	SD	Mode 3
SD	SD	G _M X M	G _M X M	Mode 4
G _M X M	G _M X M	G _M X M	G _M X M	Mode 5
SD	SD	G _{ST} X L	G _{ST} X R	Mode 6
G _{ST} X (L + R)	G _{ST} X (L + R)	G _{ST} X L	G _{ST} X R	Mode 7
G _{ST} X L	G _{ST} X R	G _{ST} X L	G _{ST} X R	Mode 8

TABLE 17. Board Connectors

Designator	Function	Comments
J1	(HPOUT) Headphone Output	Ring - Right Channel, Tip - Left Channel
J3	(V _{DD} /GND) Loudspeaker Power Supply	
J4	(V _{DD} HP/GND) Headphone Power Supply	Apply voltage on J4 when JU3 is open. DO NOT apply voltage if JU3 is closed
J29	Mini USB	
JU1	I ² CV _{DD} Select	Pin 1 = 3.3V, Pin 2 = I ² CV _{DD} , Pin 3 = GND Short Pin 1 and Pin 2 for I ² CV _{DD} = 3.3V
JU2	(HPOUT) Headphone Output	Left and Right Channel
JU3	V _{DD} HP = 1.8V	Short JU3 for V _{DD} HP = 1.8V from on board regulator
JU4	5V	Access to 5V from USB
JU6	I ² C Clock/Data	GND, SDA, SCL connections
JU7		To program USB controller
LSOUTL	Left Loudspeaker Out	
LSOUTR	Right Loudspeaker Out	
MONO_IN	Mono Input	
IN1	Stereo Input 1	
IN2	Stereo Input 2	

Bill of Materials

Bill of Materials

Ref Designator	Part Description	Manufacturer	Part Number
	LM49251TL DEMO BOARD PCB, RevA	NSC	
U1	LM49251TL	NSC	LM49251TL
U2	USB, 25 MIPS, 16 kB Flash, 10-Bit ADC, 32-Pin Mixed-Signal MCU	Silicon Labs	C8051F320-GQ
U3	Ultra Low Noise, 150mA Linear Regulator for RF/Analog Circuits Requires No Bypass Capacitor	NSC	LP5900TL-1.8/NOPB
C12, C13, C14, C39, C40	CAP CER 4.7UF 10V X5R 0603 10%	Taiyo Yuden	LMK107BJ475KA-T
C10, C38, C41	CAP .1UF 25V CERAMIC X7R 0603 5%	Kemet	C0603C104J3RACTU
R3	NO LOAD	NO LOAD	NO LOAD
C11, C9, C15, C8, C7	CAP CER 2.2UF 10V X7R 0603 10%	Murata	GRM188R71A225KE15D
L1, L2	FERRITE CHIP 30 OHM 2200MA 0402	Murata	BLM15PD300SN1D
C22, C37	CAP CERM .47UF 16V X7R 0603 10%	Kemet	C0603C474K4RACTU
C1, C2, C3, C4, C5, C6	CAP CER .22UF 10V 10% X7R 0603	Murata	GRM188R71A224KA01D
R1, R2 R4, R5	RES 10.0K OHM 1/10W 1% 0603 SMD	Panasonic	ERJ-3EKF1002V
J29	CONN RECEPT MINI USB2.0 5POS	Hirose	UX60-MB-5ST
JU1, JU6, JU7	CONN HEADR BRKWAY .100 03POS STR	Tyco	9-146285-0-03
J3, J4, JU2, LSOUTL, LSOUTR, Jw	CONN HEADR BRKWAY .100 02POS STR	Tyco	9-146285-0-02
Mono_IN, In, In1	CONN HDR BRKWAY .100 04POS VERT	Tyco	9-146282-0-04
J1	CONN JACK STEREO 3.5MM HORIZONTAL	Switchcraft	35RAPC4BH3
JU3, JU7, JU1,	Jumper Shunt w/handle, 30µin gold plated, 0.100in pitch	Tyco/AMP	881545-2

Demo Board Schematic Diagram

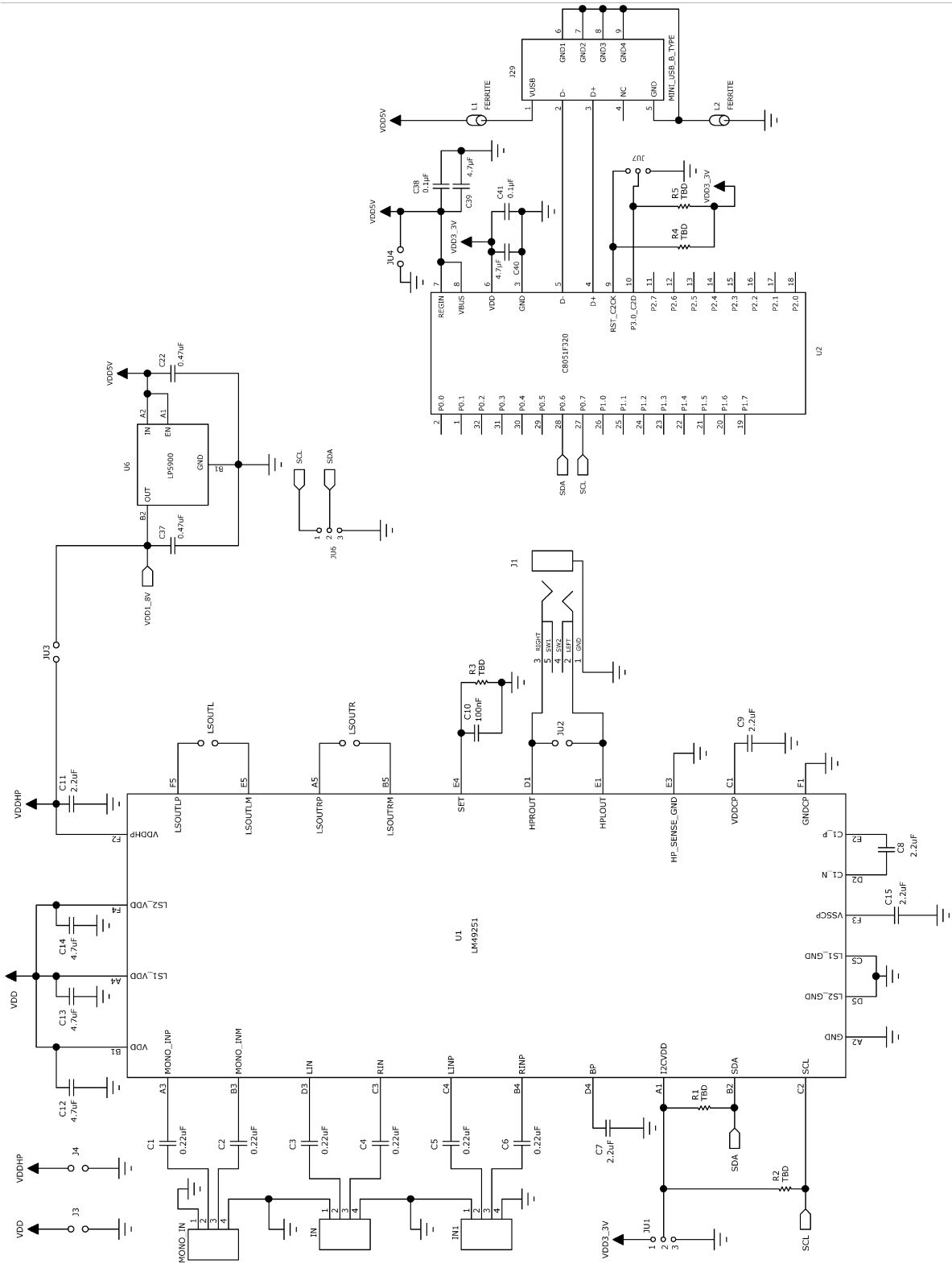

30121612

Demo Board Layout

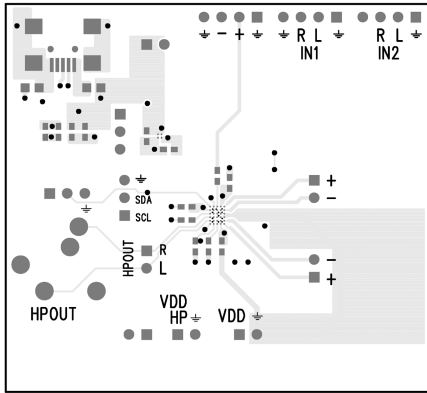

Top Layer

30121821

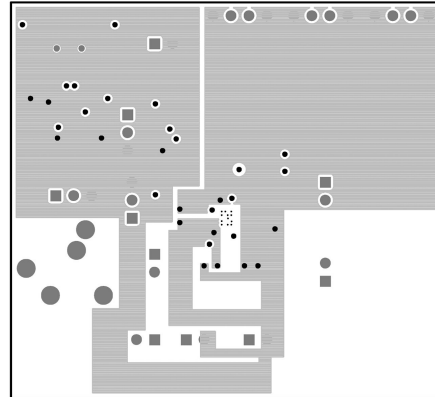

Layer 2

30121815

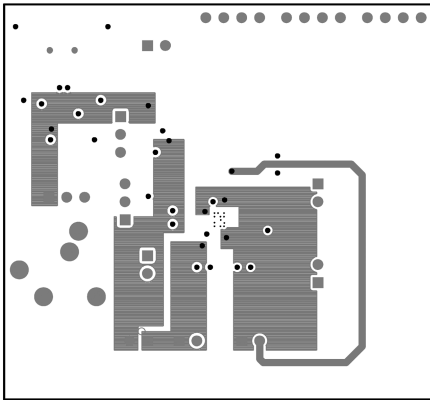

Layer 3

30121816

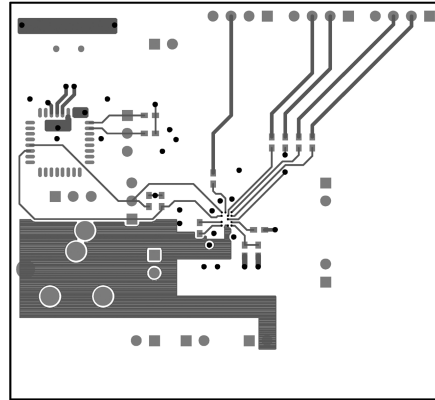

Bottom Layer

30121814

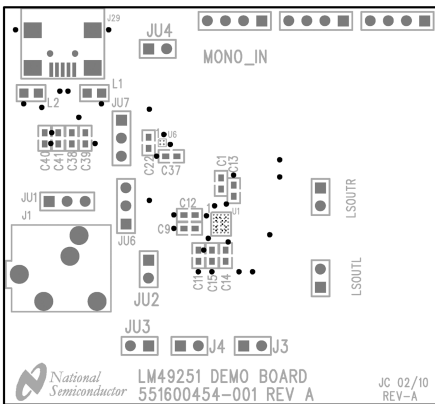

Top Silkscreen

30121820

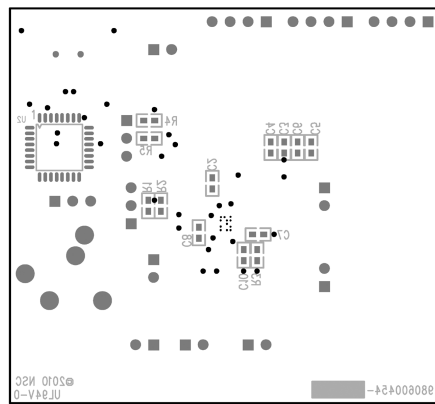

Bottom Silkscreen

30121819

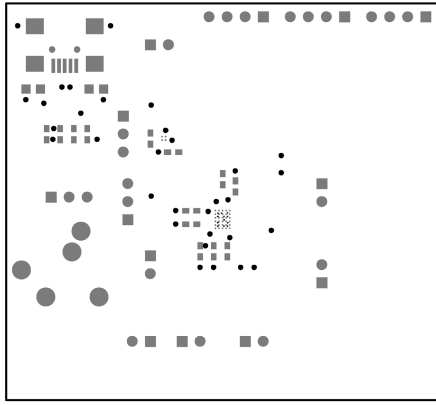

30121818

Paste Mask Top Layer

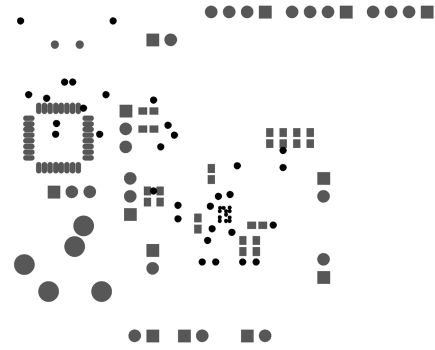

30121817

Past Mask Bottom Layer

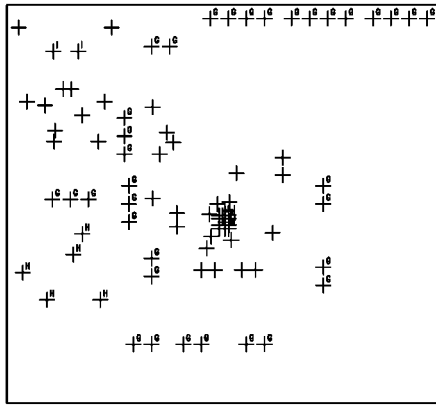

30121813

Drill Drawing

Revision History

Rev	Date	Description
1.0	02/08/11	Initial Web released.

Notes

LM49251

Notes

For more National Semiconductor product information and proven design tools, visit the following Web sites at:
www.national.com

Products		Design Support	
Amplifiers	www.national.com/amplifiers	WEBENCH® Tools	www.national.com/webench
Audio	www.national.com/audio	App Notes	www.national.com/appnotes
Clock and Timing	www.national.com/timing	Reference Designs	www.national.com/refdesigns
Data Converters	www.national.com/adc	Samples	www.national.com/samples
Interface	www.national.com/interface	Eval Boards	www.national.com/evalboards
LVDS	www.national.com/lvds	Packaging	www.national.com/packaging
Power Management	www.national.com/power	Green Compliance	www.national.com/quality/green
Switching Regulators	www.national.com/switchers	Distributors	www.national.com/contacts
LDOs	www.national.com/lido	Quality and Reliability	www.national.com/quality
LED Lighting	www.national.com/led	Feedback/Support	www.national.com/feedback
Voltage References	www.national.com/vref	Design Made Easy	www.national.com/easy
PowerWise® Solutions	www.national.com/powerwise	Applications & Markets	www.national.com/solutions
Serial Digital Interface (SDI)	www.national.com/sdi	Mil/Aero	www.national.com/milaero
Temperature Sensors	www.national.com/tempensors	SolarMagic™	www.national.com/solarmagic
PLL/VCO	www.national.com/wireless	PowerWise® Design University	www.national.com/training

THE CONTENTS OF THIS DOCUMENT ARE PROVIDED IN CONNECTION WITH NATIONAL SEMICONDUCTOR CORPORATION ("NATIONAL") PRODUCTS. NATIONAL MAKES NO REPRESENTATIONS OR WARRANTIES WITH RESPECT TO THE ACCURACY OR COMPLETENESS OF THE CONTENTS OF THIS PUBLICATION AND RESERVES THE RIGHT TO MAKE CHANGES TO SPECIFICATIONS AND PRODUCT DESCRIPTIONS AT ANY TIME WITHOUT NOTICE. NO LICENSE, WHETHER EXPRESS, IMPLIED, ARISING BY ESTOPPEL OR OTHERWISE, TO ANY INTELLECTUAL PROPERTY RIGHTS IS GRANTED BY THIS DOCUMENT.

TESTING AND OTHER QUALITY CONTROLS ARE USED TO THE EXTENT NATIONAL DEEMS NECESSARY TO SUPPORT NATIONAL'S PRODUCT WARRANTY. EXCEPT WHERE MANDATED BY GOVERNMENT REQUIREMENTS, TESTING OF ALL PARAMETERS OF EACH PRODUCT IS NOT NECESSARILY PERFORMED. NATIONAL ASSUMES NO LIABILITY FOR APPLICATIONS ASSISTANCE OR BUYER PRODUCT DESIGN. BUYERS ARE RESPONSIBLE FOR THEIR PRODUCTS AND APPLICATIONS USING NATIONAL COMPONENTS. PRIOR TO USING OR DISTRIBUTING ANY PRODUCTS THAT INCLUDE NATIONAL COMPONENTS, BUYERS SHOULD PROVIDE ADEQUATE DESIGN, TESTING AND OPERATING SAFEGUARDS.

EXCEPT AS PROVIDED IN NATIONAL'S TERMS AND CONDITIONS OF SALE FOR SUCH PRODUCTS, NATIONAL ASSUMES NO LIABILITY WHATSOEVER, AND NATIONAL DISCLAIMS ANY EXPRESS OR IMPLIED WARRANTY RELATING TO THE SALE AND/OR USE OF NATIONAL PRODUCTS INCLUDING LIABILITY OR WARRANTIES RELATING TO FITNESS FOR A PARTICULAR PURPOSE, MERCHANTABILITY, OR INFRINGEMENT OF ANY PATENT, COPYRIGHT OR OTHER INTELLECTUAL PROPERTY RIGHT.

LIFE SUPPORT POLICY

NATIONAL'S PRODUCTS ARE NOT AUTHORIZED FOR USE AS CRITICAL COMPONENTS IN LIFE SUPPORT DEVICES OR SYSTEMS WITHOUT THE EXPRESS PRIOR WRITTEN APPROVAL OF THE CHIEF EXECUTIVE OFFICER AND GENERAL COUNSEL OF NATIONAL SEMICONDUCTOR CORPORATION. As used herein:

Life support devices or systems are devices which (a) are intended for surgical implant into the body, or (b) support or sustain life and whose failure to perform when properly used in accordance with instructions for use provided in the labeling can be reasonably expected to result in a significant injury to the user. A critical component is any component in a life support device or system whose failure to perform can be reasonably expected to cause the failure of the life support device or system or to affect its safety or effectiveness.

National Semiconductor and the National Semiconductor logo are registered trademarks of National Semiconductor Corporation. All other brand or product names may be trademarks or registered trademarks of their respective holders.

Copyright© 2011 National Semiconductor Corporation

For the most current product information visit us at www.national.com



National Semiconductor Americas Technical Support Center
 Email: support@nsc.com
 Tel: 1-800-272-9959

National Semiconductor Europe Technical Support Center
 Email: europe.support@nsc.com

National Semiconductor Asia Pacific Technical Support Center
 Email: ap.support@nsc.com

National Semiconductor Japan Technical Support Center
 Email: jpn.feedback@nsc.com