



### Features

- 16 Pin SOIC Package (PCMCIA Compatible)
- Couples Analog and Digital Signals
- Wide Bandwidth (>200kHz)
- High Gain Stability
- Low Input/Output Capacitance
- Low Power Consumption
- 0.01% Servo Linearity
- THD 87dB Typical
- Machine Insertable, Wave Solderable
- Surface Mount and Tape Reel Versions Available

### Applications

- Modem Transformer Replacement With No Insertion Loss
- Digital Telephone Isolation
- Power Supply Feedback Voltage/Current
- Medical Sensor Isolation
- Audio Signal Interfacing
- Isolation of Process Control Transducers

### Description

The LOC211P Dual Linear Optocoupler features an infrared LED optically coupled with two phototransistors. One feedback (input) phototransistor is used to generate a control signal that provides a servomechanism to the LED drive current, thus compensating for the LEDs nonlinear time and temperature characteristics. The other (output) phototransistor provides an output signal that is linear with respect to the servo LED current. The product features wide bandwidth, high input to output isolation and excellent servo linearity.

### Approvals

- UL Recognized: File Number E76270
- CSA Certified: File Number LR 43639-10
- Certified to:
  - EN 60950
  - EN 41003

### Pin Configuration

LOC211 Pinout

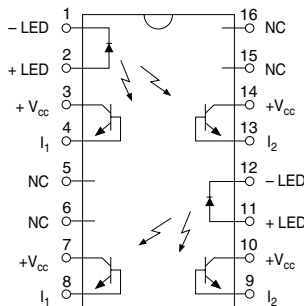

### Ordering Information

Part #	Description
LOC211P	16 Pin Flatpack (50/Tube)
LOC211PTR	16 Pin Flatpack (1000/Reel)

### K3 Sorted Bins

Bin 1 = 0.733 - 0.886
Bin 2 = 0.887 - 1.072

### Bin Matrix

Suffix	Bin	
	Top Pole Optocoupler*	Bottom Pole Optocoupler**
K	1	1
L	1	2
M	2	1
N	2	2

\*Top Pole Optocoupler: Pins 1,2,3,4,13, and 14  
 \*\*Bottom Pole Optocouplers: Pins 7 through 12

- Orders for the LOC211P product will be shipped using bins available at the date of the order. Any bin can be shipped.

### Part Number Information

The LOC211 are shipped in anti-static tubes (50 pieces each) or tape/reel (1,000 pieces each). Each container has only 1 bin combination which will be branded on each part with the appropriate bin letter K, L, M, or N in the lower right hand corner. Suffix representation is described in the "Bin Matrix".

**Absolute Maximum Ratings (@ 25° C)**

Parameter	Min	Typ	Max	Units
Input Power Dissipation	-	-	150 <sup>1</sup>	mW
Input Control Current	-	-	100	mA
Input LED Reverse Voltage	-	-	5	V
Peak (10ms)	-	-	1	A
Total Package Dissipation	-	-	800 <sup>2</sup>	mW
Isolation Voltage Input to Output	3750	-	-	V <sub>RMS</sub>
Operational Temperature	-40		+85	°C
Storage Temperature	-40	-	+125	°C
Soldering Temperature (10 Seconds Max)	-	-	+220	°C

<sup>1</sup> Derate Linearly 1.33 mW/°C

<sup>2</sup> Derate Linearly 6.67 mW/°C

*Absolute Maximum Ratings are stress ratings. Stresses in excess of these ratings can cause permanent damage to the device. Functional operation of the device at conditions beyond those indicated in the operational sections of this data sheet is not implied.*

**Electrical Characteristics**

Parameter	Conditions	Symbol	Min	Typ	Max	Units
<b>Input Characteristics @ 25°C</b>						
LED Voltage Drop	I <sub>F</sub> =2-10mA	V <sub>F</sub>	0.9	1.2	1.4	V
Reverse LED Current	V <sub>R</sub> =5V	I <sub>R</sub>	-	-	10	µA
<b>Coupler/Detector Characteristics @ 25°C</b>						
Dark Current	I <sub>F</sub> =0mA, V <sub>CC</sub> =15V	I <sub>D</sub>	-	1	25	nA
K1, Servo Gain (I <sub>1</sub> /I <sub>F</sub> )	I <sub>F</sub> =2-10mA, V <sub>CC</sub> =15V	K1	0.008	-	0.030	-
K2, Forward Gain (I <sub>2</sub> /I <sub>F</sub> )	I <sub>F</sub> =2-10mA, V <sub>CC</sub> =15V	K2	0.006	-	0.030	-
K3, Transfer Gain (K <sub>2</sub> /K <sub>1</sub> )	I <sub>F</sub> =2-10mA, V <sub>CC</sub> =15V	K3	0.733	-	1.072	-
ΔK3, Transfer Gain Linearity (non-servoed)	I <sub>F</sub> =2-10mA	ΔK3	-	-	1.0	%
K3 Temperature Coefficient	I <sub>F</sub> =2-10mA, V <sub>det</sub> =-5V	ΔK3/ΔT	-	0.005	-	%/°C
Common Mode Rejection Ratio	V=20V <sub>p-p</sub> , R <sub>L</sub> =2KΩ, F=100Hz	CMRR	-	130	-	dB
Total Harmonic Distortion	F <sub>0</sub> =350Hz, 0dBm	THD	-96	-87	-80	dB
Frequency Response	Photoconductive Operation	BW (-3dB)	-	200	-	kHz
	Photovoltaic Operation	BW (-3dB)	-	-	40	kHz
Input/Output Capacitance	-	C <sub>I/O</sub>	-	3	-	pF

NOTE: All parameters above are for each optocoupler.

**PERFORMANCE DATA\***

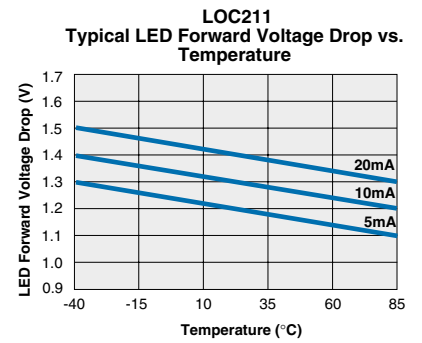
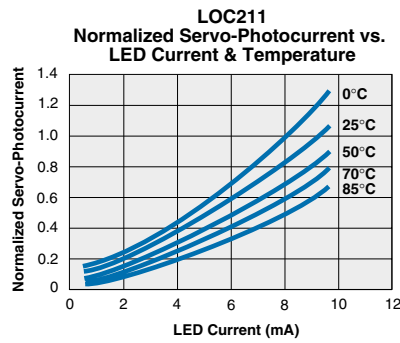
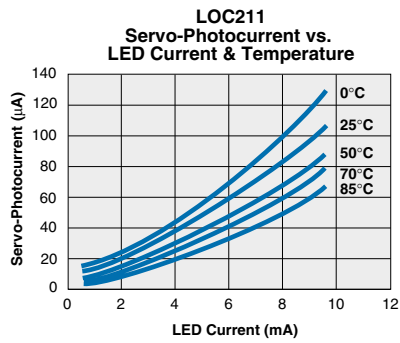
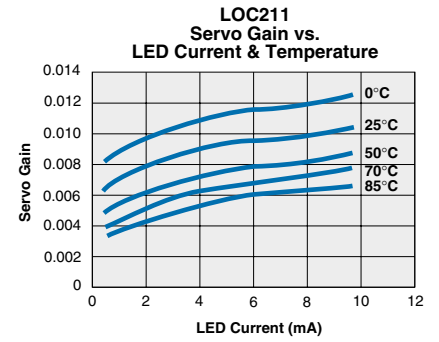
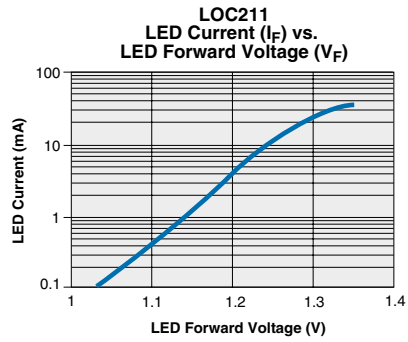
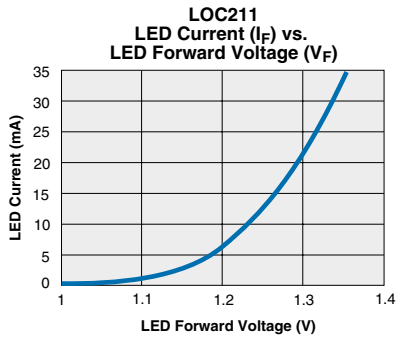

\* The Performance data shown in the graphs above is typical of device performance. For guaranteed parameters not indicated in the written specifications, please contact our application department.

**MECHANICAL DATA**

**16 Pin SOIC ("P" Suffix)**

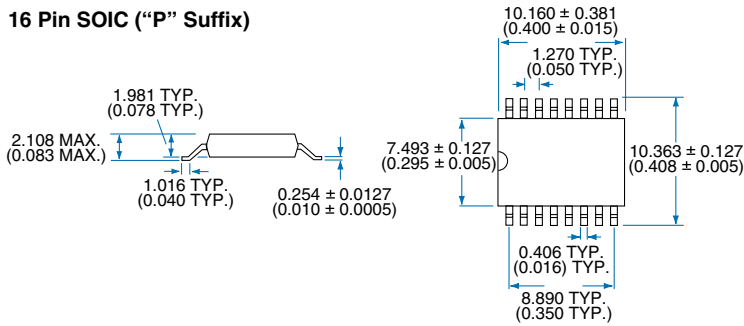

**PC Board Pattern (Top View)**

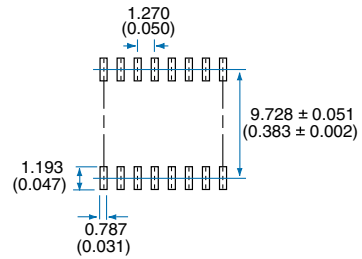

**Tape and Reel Packaging for 16 Pin SOIC Package**

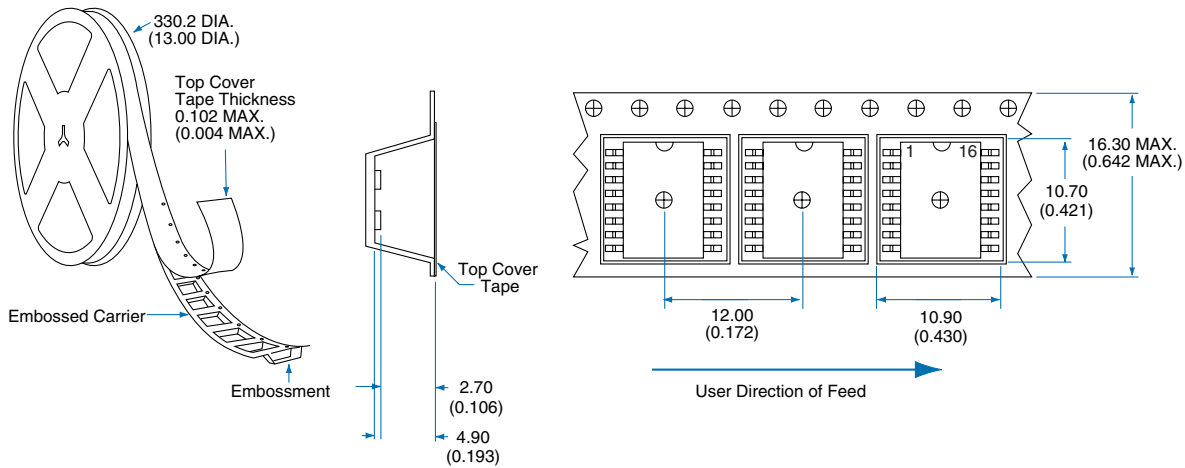

**Dimensions**  
mm  
(inches)

**For additional information please visit our website at: [www.clare.com](http://www.clare.com)**

Clare, Inc. makes no representations or warranties with respect to the accuracy or completeness of the contents of this publication and reserves the right to make changes to specifications and product descriptions at any time without notice. Neither circuit patent licenses nor indemnity are expressed or implied. Except as set forth in Clare's Standard Terms and Conditions of Sale, Clare, Inc. assumes no liability whatsoever, and disclaims any express or implied warranty, relating to its products including, but not limited to, the implied warranty of merchantability, fitness for a particular purpose, or infringement of any intellectual property right.

The products described in this document are not designed, intended, authorized or warranted for use as components in systems intended for surgical implant into the body, or in other applications intended to support or sustain life, or where malfunction of Clare's product may result in direct physical harm, injury, or death to a person or severe property or environmental damage. Clare, Inc. reserves the right to discontinue or make changes to its products at any time without notice.

Specification: DS-LOC211P-R4.4  
©Copyright 2003, Clare, Inc.  
OptoMOS® is a registered trademark of Clare, Inc.  
All rights reserved. Printed in USA.  
2/6/03