

MAX9288/MAX9290

3.12Gbps GMSL Deserializers for Coax or STP Input and MIPI CSI-2 Output

General Description

The MAX9288/MAX9290 gigabit multimedia serial link (GMSL) deserializers receive data from a GMSL serializer over 50Ω coax or 100Ω shielded twisted-pair (STP) cable and output deserialized data on the CSI-2 outputs.

The MAX9290 has HDCP content protection but otherwise is the same as the MAX9288. The deserializers pair with any GMSL serializer capable of coax output. When programmed for STP input, they are backward compatible with any GMSL serializer.

The audio channel supports L-PCM I²S stereo and up to eight channels of L-PCM in TDM mode. Sample rates of 32kHz to 192kHz are supported with sample depth up to 32 bits.

The embedded control channel operates at 9.6kbps to 1Mbps in UART-to-UART and UART-to-I²C modes, and up to 1Mbps in I²C-to-I²C mode. Using the control channel, a μ C can program serializer, deserializer, and peripheral device registers at any time, independent of video timing, and manage HDCP operation (MAX9290). Two GPIO ports are included, allowing display power-up and switching of the backlight, among other uses. A continuously sampled GPI input supports touch-screen controller interrupt requests in display applications.

For use with longer cables, the deserializers have a programmable cable equalizer. The serial input meets ISO 10605 and IEC 61000-4-2 ESD standards. The GMSL supply is 3.0V to 3.6V, the MIPI CSI-2 supply is 1.7V to 1.9V, and the I/O supply is 1.7V to 3.6V.

The devices are available in lead(Pb)-free, 48-pin, 7mm x 7mm TQFN and QFND packages with exposed pad and 0.5mm lead pitch.

Applications

- High-Resolution Automotive Navigation
- Rear-Seat Infotainment
- Megapixel Camera Systems

Simplified Diagram

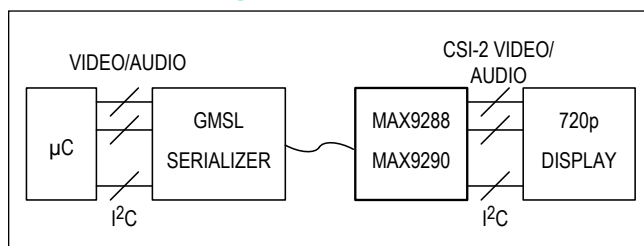

Benefits and Features

- Ideal for High-Definition Video Applications
 - 4-Lane CSI-2 Output with Up to 1Gbps Per Lane
 - Works with Low-Cost 50Ω Coax Cable and FAKRA Connectors or 100Ω STP
 - 104MHz High-Bandwidth Mode Supports 1920 x 720p/60Hz Display with 24-Bit Color
 - Equalization Allows 15m Cable at Full Speed
 - Up to 192kHz Sample Rate and 32-Bit Sample Depth For 7.1 Channel HD Audio
 - Audio Clock from Audio Source or Audio Sink
 - Color Lookup Table for Gamma Correction
 - CNTL0–CNTL3 Control Outputs for HDMI/MHL
- Multiple Data Rates for System Flexibility
 - Up to 3.12Gbps Serial-Bit Rate
 - 6.25MHz to 104MHz Pixel Clock
 - 9.6kbps to 1Mbps Control Channel in UART, Mixed UART/I²C, or I²C Mode with Clock-Stretch Capability
- Reduces EMI and Shielding Requirements
 - Tracks Spread Spectrum on Input
 - High-Immunity Mode for Maximum Control-Channel Noise Rejection
- Peripheral Features for System Power-Up and Verification
 - Built-In PRBS Tester for BER Testing of the Serial Link
 - Programmable Choice of 8 Default Device Addresses
 - Two Dedicated GPIO Ports
 - Dedicated “Up/Down” GPI for Touch-Screen Interrupt and Other Uses
 - Remote/Local Wake-Up from Sleep Mode
- Meets Rigorous Automotive and Industrial Requirements
 - -40°C to +105°C Operating Temperature
 - \pm 8kV Contact and \pm 12kV Air ISO 10605 and IEC 61000-4-2 ESD Protection

Ordering Information appears at end of data sheet.

TABLE OF CONTENTS

General Description	1
Applications	1
Benefits and Features	1
Simplified Diagram	1
Absolute Maximum Ratings	8
Package Thermal Characteristics (Note 2)	8
DC Electrical Characteristics	8
AC Electrical Characteristics	12
Typical Operating Characteristics	16
Pin Configuration	18
Pin Description	18
Functional Diagram	21
Detailed Description	27
Register Mapping	27
Output Bit Map	28
Serial Link Signaling and Data Format	28
GMSL-to-CSI-2 Conversion and Output	28
Video Data Operation	28
Auto Pixel-Per-Line Feature	48
Clock Operation	49
Data-Rate Selection and CSI-2 Clock Limitations	49
GMSL Clock Range	50
CSI-2 Clock Range	50
High-Bandwidth Mode	50
Audio Channel	50
Audio Channel Input	50
Audio Channel Output	58
Additional MCLK Output for Audio Applications	58
Audio Output Timing Sources	58
Reverse Control Channel	58
Control Channel and Register Programming	59
UART Interface	59
Interfacing Command-Byte-Only I ² C Devices with UART	61
UART Bypass Mode	61
I ² C Interface	62
START and STOP Conditions	63
Bit Transfer	63

TABLE OF CONTENTS (continued)

Acknowledge	63
Slave Address	64
Bus Reset.	65
Format for Reading	66
I ² C Communication with Remote-Side Devices	66
I ² C Address Translation	67
GPO/GPI Control	67
Line Equalizer	67
HS/VS/DE Tracking.	67
Serial Input	67
Coax Splitter Mode	68
Cable Type Configuration Input	69
Color Lookup Tables	69
Programming and Verifying LUT Data.	69
LUT Color Translation	69
LUT Bit Width.	70
Recommended LUT Program Procedure	70
High-Immunity Reverse Control-Channel Mode.	71
Sleep Mode.	71
Power-Down Mode	71
Configuration Link	72
Link Startup Procedure	72
High-Bandwidth Digital Content Protection (HDCP)	73
Encryption Enable.	73
Synchronization of Encryption	73
Repeater Support	73
HDCP Authentication Procedures	74
HDCP Protocol Summary	74
Example Repeater Network—Two μ Cs	78
Detection and Action Upon New Device Connection.	78
Notification of Start of Authentication and Enable of Encryption to Downstream Links	82
Applications Information.	82
Self PRBS Test	82
Error Checking	82
$\overline{\text{ERR}}$ Output.	82
Auto Error Reset	83
Dual μ C Control	83
Changing the Clock Frequency.	83

TABLE OF CONTENTS (continued)

Spread-Spectrum Clock Tracking	83
Fast Detection of Loss-of-Synchronization	83
Providing a Frame Sync (Camera Applications)	83
Software Programming of the Device Addresses	83
Three-Level Configuration Inputs	84
Configuration Blocking	84
Compatibility with Other GMSL Devices	84
Key Memory	84
HS/VS/DE Inversion	84
WS/SCK Inversion	84
GPIOs	84
Line-Fault Detection	84
Internal Input Pulldowns	85
Choosing I ² C/UART Pullup Resistors	85
AC-Coupling	85
Selection of AC-Coupling Capacitors	85
Power-Supply Circuits and Bypassing	85
Power-Supply Table	85
Cables and Connectors	85
Board Layout	85
ESD Protection	87
Typical Application Circuit	102
Ordering Information	102
Chip Information	102
Package Information	102
Revision History	103

LIST OF FIGURES

Figure 1. Line Fault	22
Figure 2. Reverse Control-Channel Output Parameters	23
Figure 3. Test Circuit for Differential Input Measurement	23
Figure 4. Test Circuit for Single-Ended Input Measurement	23
Figure 5. Worst-Case Pattern Output	24
Figure 6. I ² C Timing Parameters	24
Figure 7. Output Rise-and-Fall Times	25
Figure 8. Deserializer Delay	25
Figure 9. GPI-to-GPO Delay	26
Figure 10. Lock Time	26
Figure 11. Power-Up Delay	26
Figure 12. Output I ² S Timing Parameters	26
Figure 13. MIPI Output Timing Parameters	27
Figure 14. 24-Bit Mode Serial Data Format	29
Figure 15. 32-Bit Mode Serial Data Format	29
Figure 16. High-Bandwidth Mode Serial-Data Format	30
Figure 17. Transmitting a Frame from GMSL to MIPI	30
Figure 18. RGB565 Output	31
Figure 19. RGB666 Output	32
Figure 20. RGB888 Output	33
Figure 21. YUV422 8-Bit (Muxed) Output	34
Figure 22. YUV422 10-Bit (Muxed) Output	35
Figure 23. YUV422 8-Bit Output	36
Figure 24. YUV422 10-Bit Output	37
Figure 25. YUV422 12-Bit Output	38
Figure 26. RAW 8-Bit (Double Load) Output	39
Figure 27. RAW 10-Bit (Double Load) Output	40
Figure 28. RAW 12-Bit (Double Load) Output	41
Figure 29. RAW 8-Bit Output	42
Figure 30. RAW 10-Bit Output	43
Figure 31. RAW 12-Bit Output	44

LIST OF FIGURES (continued)

Figure 32. RAW 14-Bit Output	45
Figure 33. User-Defined 24-Bit Output	46
Figure 34. User-Defined 24-Bit Output	47
Figure 35. Audio Channel Input Format.	50
Figure 36. 8-Channel TDM (24-Bit Samples, Padded with Zeros)	57
Figure 37. 6-Channel TDM (24-Bit Samples, No Padding)	57
Figure 38. Stereo I ² S (24-Bit Samples, Padded with Zeros).	57
Figure 39. Stereo I ² S (16-Bit Samples, No Padding)	58
Figure 40. Audio Channel Output Format	59
Figure 41. GMSL UART Protocol for Base Mode	60
Figure 42. GMSL UART Data Format for Base Mode	60
Figure 43. SYNC Byte (0x79).	60
Figure 44. ACK Byte (0xC3).	60
Figure 45. Format Conversion Between GMSL UART and I ² C with Register Address (I2CMETHOD = 0).	61
Figure 46. Format Conversion Between GMSL UART and I ² C without Register Address (I2CMETHOD = 1)	62
Figure 47. START and STOP Conditions	63
Figure 48. Bit Transfer	63
Figure 49. Acknowledge.	64
Figure 50. Slave Address.	64
Figure 51. Format for I ² C Write	65
Figure 52. Format for Write to Multiple Registers	65
Figure 53. Format for I ² C Read	66
Figure 54. 2:1 Coax Splitter Connection Diagram.	68
Figure 55. Coax Connection Diagram	68
Figure 56. LUT Dataflow	70
Figure 57. State Diagram (CDS = High).	78
Figure 58. Example Network with One Repeater and Two μ Cs (Tx = GMSL Serializer's, Rx = Deserializer's).	78
Figure 59. Human Body Model ESD Test Circuit.	87
Figure 60. IEC 61000-4-2 Contact Discharge ESD Test Circuit	87
Figure 61. ISO 10605 Contact Discharge ESD Test Circuit	87

LIST OF TABLES

Table 1. Device Address Defaults (Register 0x00, 0x01)	28
Table 2 Video Output Map (RGB and YUV)	48
Table 3. Video Output Map (RAW and User Defined)	49
Table 4. Control Output Map	51
Table 5. GMSL Data-Rate Selection Table	51
Table 6. Input Pixel Clock Range (MHz)	51
Table 7. Output CSI-2 Data Rate Range (Mbps)	54
Table 8. Maximum Audio WS Frequency (kHz) for Various Pixel Clock Frequencies.	56
Table 9. f _{SRC} Settings	59
Table 10. I ² C Bit-Rate Ranges.	66
Table 11. Cable Equalizer Boost Levels.	67
Table 12. Configuration Input Map.	69
Table 13. Pixel Data Format.	69
Table 14. Reverse Control-Channel Modes.	71
Table 15. Fast High-Immunity Mode Requirements.	71
Table 16. Startup Procedure for Image-Sensing Applications (CDS = High, Figure 58)	72
Table 17. Startup, HDCP Authentication, and Normal Operation (Deserializer is Not a Repeater)—First Part of the HDCP Authentication Protocol	74
Table 18. Link Integrity Check (Normal)—Performed Every 128 Frames After Encryption is Enabled	76
Table 19. Optional Enhanced Link Integrity Check—Performed Every 16 Frames After Encryption is Enabled	77
Table 20. HDCP Authentication and Normal Operation (One Repeater, Two μ Cs)—First and Second Parts of the HDCP Authentication Protocol	79
Table 21. MAX9288/MAX9290 Feature Compatibility	84
Table 22. Line-Fault Mapping	86
Table 23. Additional Supply Current from HDCP (MAX9290 Only).	86
Table 24. Suggested Connectors and Cables for GMSL.	86
Table 25. Register Table	88
Table 26. HDCP Register Table (MAX9290 Only).	100
Table 26. HDCP Register Table (MAX9290 Only).	101

Absolute Maximum Ratings (Note 1)

AVDD3 to EP	-0.5V to +3.9V
AVDD18, DVDD18 to EP.....	-0.5V to +1.9V
IOVDD to EP	-0.5V to +3.9V
IN+, IN- to EP	-0.5V to +1.9V
LMN_ to EP (15mA current limit).....	-0.5V to +3.9V
CLK_, DOUT_ to EP	-0.5V to +1.9V
All Other Pins to EP	-0.5V to (V _{IOVDD} + 0.5V)
IN+, IN- Short Circuit to Ground or Supply	Continuous

Continuous Power Dissipation (T _A = +70°C)	
TQFN (derate 40mW/°C above +70°C).....	3200mW
QFND (derate 38.5mW/°C above +70°C).....	3076.9mW
Junction Temperature.....	+150°C
Storage Temperature.....	-65°C to +150°C
Lead Temperature (soldering, 10s)	+300°C
Soldering Temperature (reflow)	+260°C

Note 1: EP connected to PCB ground.

Stresses beyond those listed under "Absolute Maximum Ratings" may cause permanent damage to the device. These are stress ratings only, and functional operation of the device at these or any other conditions beyond those indicated in the operational sections of the specifications is not implied. Exposure to absolute maximum rating conditions for extended periods may affect device reliability.

Package Thermal Characteristics (Note 2)

TQFN		QFND	
Junction-to-Ambient Thermal Resistance (θ _{JA})	25°C/W	Junction-to-Ambient Thermal Resistance (θ _{JA})	26°C/W
Junction-to-Case Thermal Resistance (θ _{JC}).....	1°C	Junction-to-Case Thermal Resistance (θ _{JC}).....	1°C

Note 2: Package thermal resistances were obtained using the method described in JEDEC specification JESD51-7, using a four-layer board. For detailed information on package thermal considerations, refer to www.maximintegrated.com/thermal-tutorial.

DC Electrical Characteristics

(V_{AVDD18} = V_{DVDD18} = 1.7V to 1.9V, V_{AVDD3} = 3.0V to 3.6V, V_{IOVDD} = 1.7V to 3.6V, R_L = 100Ω ±1% (differential), EP connected to PCB ground (GND), T_A = -40°C to +105°C, unless otherwise noted. Typical values are at V_{AVDD18} = V_{DVDD18} = V_{IOVDD} = 1.8V, V_{AVDD3} = 3.3V, T_A = +25°C.) (Note 3)

PARAMETER	SYMBOL	CONDITIONS	MIN	TYP	MAX	UNITS
SINGLE-ENDED INPUTS (ADD_, I2CSEL, PWDN, MS, GPI, DRS, EQS, CDS, HIM, SCK, WS)						
High-Level Input Voltage	V _{IH1}		0.65 x V _{IOVDD}			V
Low-Level Input Voltage	V _{IL1}			0.35 x V _{IOVDD}		V
Input Current	I _{IN1}	V _{IN} = 0V to V _{IOVDD}	-20		+20	µA
THREE-LEVEL LOGIC INPUTS (BWS, CX/TP)						
High-Level Input Voltage	V _{IH}		0.7 x V _{IOVDD}			V
Low-Level Input Voltage	V _{IL}			0.3 x V _{IOVDD}		V
Mid-Level Input Current	I _{INM}	(Note 4)	-10		+10	µA
Input Current	I _{IN}		-150		+150	µA
SINGLE-ENDED OUTPUTS (WS, SCK, SD, CNTL_, INTOUT)						
High-Level Output Voltage	V _{OH1}	I _{OUT} = -2mA	DCS = 0		V _{IOVDD} - 0.3	V
			DCS = 1		V _{IOVDD} - 0.2	
Low-Level Output Voltage	V _{OL1}	I _{OUT} = 2mA	DCS = 0		0.3	V
			DCS = 1		0.2	

DC Electrical Characteristics (continued)

($V_{AVDD18} = V_{DVDD18} = 1.7V$ to $1.9V$, $V_{AVDD3} = 3.0V$ to $3.6V$, $V_{IOVDD} = 1.7V$ to $3.6V$, $R_L = 100\Omega \pm 1\%$ (differential), EP connected to PCB ground (GND), $T_A = -40^\circ C$ to $+105^\circ C$, unless otherwise noted. Typical values are at $V_{AVDD18} = V_{DVDD18} = V_{IOVDD} = 1.8V$, $V_{AVDD3} = V_{IOVDD} = 3.3V$, $T_A = +25^\circ C$.)

PARAMETER	SYMBOL	CONDITIONS		MIN	TYP	MAX	UNITS
Output Short-Circuit Current	I_{OS}	$V_O = 0V$, DCS = 0	$V_{IOVDD} = 3.0V$ to $3.6V$	15	25	39	mA
			$V_{IOVDD} = 1.7V$ to $1.9V$	3	7	15	
		$V_O = 0V$, DCS = 1	$V_{IOVDD} = 3.0V$ to $3.6V$	20	35	63	
			$V_{IOVDD} = 1.7V$ to $1.9V$	5	10	21	
MIPI HIGH-SPEED DIFFERENTIAL OUTPUT PORTS (DOUT0–DOUT3_, CLK_) (Note 3)							
Transmit Static Common-Mode Voltage	V_{CMTX}			150	200	250	mV
V_{CMTX} Mismatch When Output is Differential 1 or 0	$ \Delta V_{CMT(1,0)} $					5	mV
Transmit Differential Voltage	$ V_{OD} $			140	200	270	mV
V_{OD} Mismatch When Output is Differential 1 or 0	$ \Delta V_{OD} $					14	mV
Output High Voltage	V_{OHHS}					360	mV
Single-Ended Output Impedance	Z_{OS}			40	50	62.5	Ω
Single-Ended Output Impedance Mismatch	ΔZ_{OS}	Mismatch of the single-ended output impedance at both DOUT_+ and DOUT_- pins for both differential 1 and 0				10	%
MIPI LOW-SPEED SINGLE-ENDED OUTPUT PORTS (DOUT0–DOUT3_, CLK_)							
Thevenin Output High Level	V_{OH}			1.05	1.2	1.3	V
Thevenin Output Low Level	V_{OL}			-50		+50	mV
Output Impedance of Low Power Transmitter	Z_{OLP}			110			Ω
OPEN-DRAIN INPUT/OUTPUT (GPIO0, GPIO1, RX/SDA, TX/SCL, ERR, LOCK, LFLT)							
High-Level Input Voltage	V_{IH2}			0.7 x V_{IOVDD}			V
Low-Level Input Voltage	V_{IL2}					0.3 x V_{IOVDD}	V
Input Current	I_{IN2}	(Note 5)	RX/SDA, TX/SCL	-100		+5	μA
			LOCK, ERR, GPIO_, LFLT	-80		+5	
Low-Level Output Voltage	V_{OL2}	$I_{OUT} = 3mA$	$V_{IOVDD} = 1.7V$ to $1.9V$			0.4	V
			$V_{IOVDD} = 3.0V$ to $3.6V$			0.3	
Input Capacitance	C_{IN}	Each pin (Note 6)				10	pF
LINE-FAULT DETECTION INPUT (LMN0, LMN1)							
Short-to-GND Threshold	V_{TG}	Figure 1				0.3	V
Normal Threshold	V_{TN}	Figure 1		0.57		1.07	V
Open Threshold	V_{TO}	Figure 1		1.45	$V_{IO} + 0.06$		V
Open Input Voltage	V_{IO}	Figure 1		1.49		1.75	V

DC Electrical Characteristics (continued)

($V_{AVDD18} = V_{DVDD18} = 1.7V$ to $1.9V$, $V_{AVDD3} = 3.0V$ to $3.6V$, $V_{IOVDD} = 1.7V$ to $3.6V$, $R_L = 100\Omega \pm 1\%$ (differential), EP connected to PCB ground (GND), $T_A = -40^\circ C$ to $+105^\circ C$, unless otherwise noted. Typical values are at $V_{AVDD18} = V_{DVDD18} = V_{IOVDD} = 1.8V$, $V_{AVDD3} = 3.3V$, $T_A = +25^\circ C$.)

PARAMETER	SYMBOL	CONDITIONS		MIN	TYP	MAX	UNITS
Short-to-Battery Threshold	V_{TB}	Figure 1		2.47			V
OUTPUT FOR REVERSE CONTROL CHANNEL (IN+, IN-)							
Differential High Output Peak Voltage (V_{IN+}) - (V_{IN-})	V_{RODH}	Forward channel disabled, Figure 2	Legacy reverse control-channel mode	30		60	mV
			High-immunity mode	50		100	
Differential Low Output Peak Voltage (V_{IN+}) - (V_{IN-})	V_{RODL}	Forward channel disabled, Figure 2	Legacy reverse control-channel mode	-60		-30	mV
			High-immunity mode	-100		-50	
Single-Ended High Output Peak Voltage	V_{ROSH}	Forward channel disabled	Legacy reverse control-channel mode	30		60	mV
			High-immunity mode	50		100	
Single-Ended Low Output Peak Voltage	V_{ROSL}	Forward channel disabled	Legacy reverse control-channel mode	-60		-30	mV
			High-immunity mode	-100		-50	
DIFFERENTIAL INPUTS (IN+, IN-)							
Differential High Input Threshold (Peak) Voltage (V_{IN+}) - (V_{IN-})	$V_{IDH(P)}$	Figure 3	Activity detector medium threshold, (0x0B D[6:5] = 01)			60	mV
			Activity detector low threshold, (0x0B D[6:5] = 00)			52	
Differential Low Input Threshold (Peak) Voltage (V_{IN+}) - (V_{IN-})	$V_{IDL(P)}$	Figure 3	Activity detector medium threshold, (0x0B D[6:5] = 01)	-60			mV
			Activity detector low threshold, (0x0B D[6:5] = 00)	-52			
Input Common-Mode Voltage ($(V_{IN+}) + (V_{IN-})/2$)	V_{CMR}			1	1.3	1.6	V
Differential Input Resistance (Internal)	R_{IN}			80	100	130	Ω
SINGLE-ENDED INPUTS (IN+, IN-)							
Single-Ended High Input Threshold (Peak) Voltage	$V_{ISH(P)}$	Figure 4	Activity detector medium threshold, (0x0B D[6:5] = 01)			43	mV
			Activity detector low threshold, (0x0B D[6:5] = 00)			36	
Single-Ended Low Input Threshold (Peak) Voltage	$V_{ISL(P)}$	Figure 4	Activity detector medium threshold, (0x0B D[6:5] = 01)	-43			mV
			Activity detector low threshold, (0x0B D[6:5] = 00)	-36			
Input Resistance (Internal)	R_I			40	50	65	Ω

DC Electrical Characteristics (continued)

($V_{AVDD18} = V_{DVDD18} = 1.7V$ to $1.9V$, $V_{AVDD3} = 3.0V$ to $3.6V$, $V_{IOVDD} = 1.7V$ to $3.6V$, $R_L = 100\Omega \pm 1\%$ (differential), EP connected to PCB ground (GND), $T_A = -40^\circ C$ to $+105^\circ C$, unless otherwise noted. Typical values are at $V_{AVDD18} = V_{DVDD18} = V_{IOVDD} = 1.8V$, $V_{AVDD3} = 3.3V$, $T_A = +25^\circ C$.) (Note 3)

PARAMETER	SYMBOL	CONDITIONS	MIN	TYP	MAX	UNITS
POWER SUPPLY						
Total Supply Current (AVDD_ + DVDD_ + IOVDD) (Note 7) (Worst-Case-Pattern, Figure 5)	I _{WCS}	BWS = low, f _{PCLKOUT} = 16.6MHz, 1 MIPI lane, RGB666	AVDD3	97	131	mA
			DVDD18	28	38	
			IOVDD	0.3	2	
			AVDD18	21	33	
			Total	146	197	
		BWS = low, f _{PCLKOUT} = 33.3MHz, 1 MIPI lanes, RGB666	AVDD3	99	134	
			DVDD18	45	62	
			IOVDD	0.3	2	
			AVDD18	25	34	
			Total	170	227	
		BWS = low, f _{PCLKOUT} = 66.6MHz, 2 MIPI lanes, RGB666	AVDD3	103	140	
			DVDD18	69	94	
			IOVDD	0.3	2	
			AVDD18	29	39	
			Total	201	270	
		BWS = low, f _{PCLKOUT} = 104MHz, 2 MIPI lanes, RGB666	AVDD3	112	152	
			DVDD18	100	139	
			IOVDD	0.3	2	
			AVDD18	46	63	
			Total	259	351	
		BWS = mid, f _{PCLKOUT} = 36.6MHz, 1 MIPI lanes, RGB888	AVDD3	100	136	
			DVDD18	51	70	
			IOVDD	0.3	2	
			AVDD18	27	36	
Total	178		236			
BWS = mid, f _{PCLKOUT} = 104MHz, 2 MIPI lanes, RGB888	AVDD3	112	153			
	DVDD18	123	169			
	IOVDD	0.3	2			
	AVDD18	55	75			
	Total	290	394			
Sleep-Mode Supply Current	I _{CCS}			44	120	μA
Power-Down Current	I _{CCZ}	PWDN = GND		12	75	μA
ESD PROTECTION						
IN+, IN- (Note 8)	V _{ESD}	Human Body Model, R _D = 1.5kΩ, C _S = 100pF		±8		kV
		IEC 61000-4-2, R _D = 330Ω, C _S = 150pF	Contact discharge	±8		
			Air discharge	±12		
		ISO 10605, R _D = 2kΩ, C _S = 330pF	Contact discharge	±8		
Air discharge	±20					
All Other Pins (Note 9)	V _{ESD}	Human Body Model, R _D = 1.5kΩ, C _S = 100pF		±2.5		kV

AC Electrical Characteristics

($V_{AVDD18} = V_{DVDD18} = 1.7V$ to $1.9V$, $V_{AVDD3} = 3.0V$ to $3.6V$, $V_{IOVDD} = 1.7V$ to $3.6V$, $R_L = 100\Omega \pm 1\%$ (differential), EP connected to PCB ground (GND), $T_A = -40^\circ C$ to $+105^\circ C$, unless otherwise noted. Typical values are at $V_{AVDD18} = V_{DVDD18} = V_{IOVDD} = 1.8V$, $V_{AVDD3} = 3.3V$, $T_A = +25^\circ C$.)

PARAMETER	SYMBOL	CONDITIONS		MIN	TYP	MAX	UNITS
I²C/UART PORT TIMING							
I ² C/UART Bit Rate				9.6		1000	kbps
Output Rise Time	t_R	30% to 70%, $C_L = 10pF$ to $100pF$, $1k\Omega$ pullup to V_{IOVDD}		20		150	ns
Output Fall Time	t_F	70% to 30%, $C_L = 10pF$ to $100pF$, $1k\Omega$ pullup to V_{IOVDD}		20		150	ns
I²C TIMING (Figure 6)							
SCL Clock Frequency	f_{SCL}	Low f_{SCL} range: (I2CMSTBT = 010, I2CSLVSH = 10)		9.6		100	kHz
		Mid f_{SCL} range: (I2CMSTBT 101, I2CSLVSH = 01)		> 100		400	
		High f_{SCL} range: (I2CMSTBT = 111, I2CSLVSH = 00)		> 400		1000	
START Condition Hold Time	$t_{HD:STA}$	f_{SCL} range	Low	4.0			μs
			Mid	0.6			
			High	0.26			
Low Period of SCL Clock	t_{LOW}	f_{SCL} range	Low	4.7			μs
			Mid	1.3			
			High	0.5			
High Period of SCL Clock	t_{HIGH}	f_{SCL} range	Low	4.0			μs
			Mid	0.6			
			High	0.26			
Repeated START Condition Setup Time	$t_{SU:STA}$	f_{SCL} range	Low	4.7			μs
			Mid	0.6			
			High	0.26			
Data Hold Time	$t_{HD:DAT}$	f_{SCL} range	Low	0			μs
			Mid	0			
			High	0			
Data Setup Time	$t_{SU:DAT}$	f_{SCL} range	Low	250			ns
			Mid	100			
			High	50			
Setup Time for STOP Condition	$t_{SU:STO}$	f_{SCL} range	Low	4.0			μs
			Mid	0.6			
			High	0.26			
Bus Free Time	t_{BUF}	f_{SCL} range	Low	4.7			μs
			Mid	1.3			
			High	0.5			

AC Electrical Characteristics (continued)

($V_{AVDD18} = V_{DVDD18} = 1.7V$ to $1.9V$, $V_{AVDD3} = 3.0V$ to $3.6V$, $V_{IOVDD} = 1.7V$ to $3.6V$, $R_L = 100\Omega \pm 1\%$ (differential), EP connected to PCB ground (GND), $T_A = -40^\circ C$ to $+105^\circ C$, unless otherwise noted. Typical values are at $V_{AVDD18} = V_{DVDD18} = V_{IOVDD} = 1.8V$, $V_{AVDD3} = 3.3V$, $T_A = +25^\circ C$.)

PARAMETER	SYMBOL	CONDITIONS		MIN	TYP	MAX	UNITS
Data Valid Time	$t_{VD:DAT}$	f_{SCL} range	Low			3.45	μs
			Mid			0.9	
			High			0.45	
Data Valid Acknowledge Time	$t_{VD:ACK}$	f_{SCL} range	Low			3.45	μs
			Mid			0.9	
			High			0.45	
Pulse Width of Spikes Suppressed	t_{SP}	f_{SCL} range	Low			50	ns
			Mid			50	
			High			50	
Capacitive Load Each Bus Line	C_b	(Note 8)				100	pF
SWITCHING CHARACTERISTICS (Note 10)							
Deserialzer Delay	t_{SD}	(Note 11) Figure 8			1388	1500	Bits
Reverse Control-Channel Output Rise Time	t_R	No forward channel data transmission, Figure 2		180		400	ns
Reverse Control-Channel Output Fall Time	t_F	No forward channel data transmission, Figure 2		180		400	ns
GPI-to-GPO Delay	t_{GPIO}	Deserialzer GPI to serializer GPO (cable delay not included), Figure 9				350	μs
Lock Time	t_{LOCK}	Figure 10 (Note 12)				4	ms
Power-Up Time	t_{PU}	Figure 11				8.5	ms
I²S/TDM OUTPUT TIMING (Note 10)							
WS Jitter	t_{jWS}	$t_{WS} = 1/f_{WS}$, (cycle-to-cycle), rising-to-falling edge or falling-to-rising edge	$f_{WS} = 48kHz$ or $44.1kHz$		$1.2e-3 \times t_{WS}$	$1.5e-3 \times t_{WS}$	ns
			$f_{WS} = 96kHz$		$1.6e-3 \times t_{WS}$	$2e-3 \times t_{WS}$	
			$f_{WS} = 192kHz$		$1.6e-3 \times t_{WS}$	$2e-3 \times t_{WS}$	
SCK Jitter (2-Channel I ² S)	t_{jSCK1}	$t_{SCK} = 1/f_{SCK}$, (cycle-to-cycle), rising-to-rising edge	$n_{SCK} = 16$ bits, $f_{WS} = 48kHz$ or $44.1kHz$		$13e-3 \times t_{SCK}$	$16e-3 \times t_{SCK}$	ns
			$n_{SCK} = 24$ bits, $f_{WS} = 96kHz$		$39e-3 \times t_{SCK}$	$48e-3 \times t_{SCK}$	
			$n_{SCK} = 32$ bits, $f_{WS} = 192kHz$		$0.1 \times t_{SCK}$	$0.13 \times t_{SCK}$	

AC Electrical Characteristics (continued)

($V_{AVDD18} = V_{DVDD18} = 1.7V$ to $1.9V$, $V_{AVDD3} = 3.0V$ to $3.6V$, $V_{IOVDD} = 1.7V$ to $3.6V$, $R_L = 100\Omega \pm 1\%$ (differential), EP connected to PCB ground (GND), $T_A = -40^\circ C$ to $+105^\circ C$, unless otherwise noted. Typical values are at $V_{AVDD18} = V_{DVDD18} = V_{IOVDD} = 1.8V$, $V_{AVDD3} = 3.3V$, $T_A = +25^\circ C$.)

PARAMETER	SYMBOL	CONDITIONS		MIN	TYP	MAX	UNITS
SCK Jitter (8-Channel TDM)	t_{jSCK2}	$t_{SCK} = 1/f_{SCK}$, (cycle-to-cycle), rising-to-rising edge	$n_{SCK} = 16$ bits, $f_{WS} = 48kHz$ or 44.1kHz		$52e-3$ $\times t_{SCK}$	$64e-3$ $\times t_{SCK}$	ns
			$n_{SCK} = 24$ bits, $f_{WS} = 96kHz$		$156e-3$ $\times t_{SCK}$	$192e-3$ $\times t_{SCK}$	
			$n_{SCK} = 32$ bits, $f_{WS} = 192kHz$		$0.4 \times$ t_{SCK}	$0.52 \times$ t_{SCK}	
Audio Skew Relative to Video	t_{ASK}	Video and audio synchronized			$3 \times$ t_{WS}	$4 \times t_{WS}$	μs
SCK, SD, WS Rise-and-Fall Time	t_R, t_F	20% to 80%	$C_L = 10pF, DCS = 1$	0.3		3.1	ns
			$C_L = 5pF, DCS = 0$	0.4		3.8	
SD, WS Valid Time Before SCK (2-Channel I ² S)	t_{DVB1}	$t_{SCK} = 1/f_{SCK}$, Figure 12		$0.20 \times t_{SCK}$	$0.5 \times$ t_{SCK}		ns
SD, WS Valid Time After SCK (2-Channel I ² S)	t_{DVA1}	$t_{SCK} = 1/f_{SCK}$, Figure 12		$0.20 \times t_{SCK}$	$0.5 \times$ t_{SCK}		ns
SD, WS Valid Time Before SCK (8-Channel TDM)	t_{DVB2}	$t_{SCK} = 1/f_{SCK}$, Figure 12		$0.20 \times t_{SCK}$	$0.5 \times$ t_{SCK}		ns
SD, WS Valid Time After SCK (8-Channel TDM)	t_{DVA2}	$t_{SCK} = 1/f_{SCK}$, Figure 12		$0.20 \times t_{SCK}$	$0.5 \times$ t_{SCK}		ns
HIGH-SPEED DIFFERENTIAL OUTPUT PORTS (DOUT0_–DOUT3_, CLK_) (Note 10)							
20% to 80% Rise Time and Fall Time	t_R, t_F	Bit rate $\leq 1Gbps$				0.3	UI
				100			ps
Data-to-Clock Skew	t_{SKW}			-0.15		+0.15	UI
UI Instantaneous	UI_{INS}			1		12.5	ns
Common-Level Variation Above 450MHz	ΔV_{CM}					15	mV _{RMS}
Common-Level Variation Between 50MHz to 450MHz						25	mV _{PEAK}
LOW-SPEED DIFFERENTIAL OUTPUT PORTS (DOUT0_–DOUT3_, CLK_) (Note 10)							
15% to 85% Rise Time and Fall Time	t_{RLP}/t_{FLP}					25	ns
30% to 85% Rise Time and Fall Time Transition from HS to LP	t_{REOP}					35	ns
GENERAL CSI-2 TIMING SPECIFICATIONS (Note 10, Figure 13)							
Start of Transmission: Clock Prepare Time	$t_{CLK-PREPARE}$	Time that the transmitter drives the clock lane LP-00 line state immediately before HS-0 line state starting the HS transition		38		95	ns

AC Electrical Characteristics (continued)

($V_{AVDD18} = V_{DVDD18} = 1.7V$ to $1.9V$, $V_{AVDD3} = 3.0V$ to $3.6V$, $V_{IOVDD} = 1.7V$ to $3.6V$, $R_L = 100\Omega \pm 1\%$ (differential), EP connected to PCB ground (GND), $T_A = -40^\circ C$ to $+105^\circ C$, unless otherwise noted. Typical values are at $V_{AVDD18} = V_{DVDD18} = V_{IOVDD} = 1.8V$, $V_{AVDD3} = 3.3V$, $T_A = +25^\circ C$.)

PARAMETER	SYMBOL	CONDITIONS	MIN	TYP	MAX	UNITS
End of Transmission: Clock Trail Time	$t_{CLK-TRAIL}$	Time that the transmitter drives the HS-0 state after the last payload clock bit of a HS transmission burst	60			ns
Clock Start of Transmission Time	$t_{CLK-PREPARE} + t_{CLK-ZERO}$	$t_{CLK-PREPARE}$ + time that the transmitter drives the HS-0 state prior to starting the clock	300			ns
Clock End of Transmission Time	t_{EOT}	Transmitted time interval from the start of $t_{HS-TRAIL}$ or $t_{CLK-TRAIL}$ to start of the LP-11 state following a HS burst			105ns + 12 x UI	ns
HS Exit Time	$t_{HS-EXIT}$	Time that the transmitter drives LP-11 following a HS burst	100			ns
Start of Transmission: Data Prepare Time	$t_{HS-PREPARE}$	Time that the transmitter drives the data lane LP-00 line state immediately before the HS-0 line state starting the HS transmission	40ns + 4 x UI		85ns + 6 x UI	ns
Start of Transition Time	$t_{HS-PREPARE} + t_{HS-ZERO}$	$t_{HS-PREPARE}$ + time that the transmitter drives the HS-0 state prior to transmitting the sync sequence	145ns + 10 x UI			ns
End of Transmission: Data Trail Time	$t_{HS-TRAIL}$	Time that the transmitter drives the flipped differential state after last payload data bit of a HS transmission burst	Max(8 x UI, 60ns + 4 x UI)			ns
LP Transmit Time	t_{LPTX}	Transmitted length of any low-power state period	50			ns

Note 3: Limits are 100% production tested at $T_A = +105^\circ C$. Limits over the operating temperature range are guaranteed by design and characterization, unless otherwise noted.

Note 4: To provide a mid level, leave the input open, or, if driven, put driver in high impedance. High-impedance leakage current must be less than $\pm 10\mu A$.

Note 5: I_{IN_min} due to voltage drop across the internal pullup resistor.

Note 6: Not production tested. Guaranteed by design.

Note 7: HDCP enabled (MAX9290 only). IOVDD current is not production tested. For the MAX9288 (or when HDCP is disabled on the MAX9290), subtract the HDCP supply current, as shown in [Table 25](#).

Note 8: Specified pin to ground.

Note 9: Specified pin to all supply/ground.

Note 10: Not production tested, guaranteed by characterization.

Note 11: Measured in serial link bit times. Bit time = $1/(30 \times f_{PIXEL})$ for BWS = 0 or open. Bit time = $1/(40 \times f_{PIXEL})$ for BWS = 1.

Typical Operating Characteristics

($V_{AVDD18} = V_{DVDD18} = V_{IOVDD} = 1.8V$, $V_{AVDD3} = 3.3V$, $T_A = +25^\circ C$, unless otherwise noted.)

SUPPLY CURRENT vs. PIXEL CLOCK FREQUENCY (BWS = LOW)

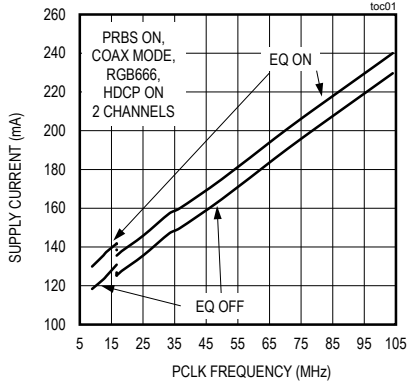

SUPPLY CURRENT vs. PIXEL CLOCK FREQUENCY (BWS = OPEN)

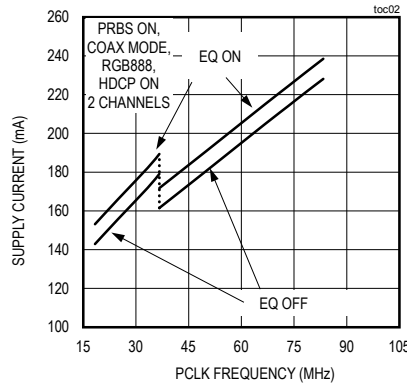

SUPPLY CURRENT vs. PIXEL CLOCK FREQUENCY (BWS = HIGH)

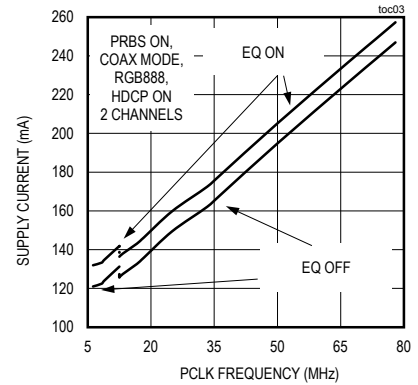

SUPPLY CURRENT vs. PIXEL CLOCK FREQUENCY (BWS = LOW)

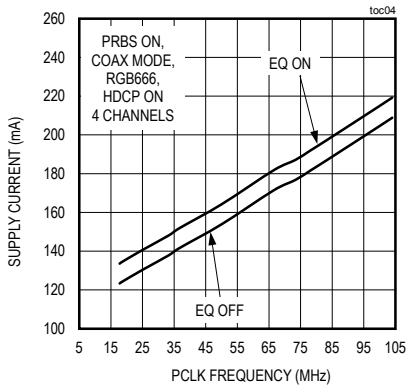

SUPPLY CURRENT vs. PIXEL CLOCK FREQUENCY (BWS = OPEN)

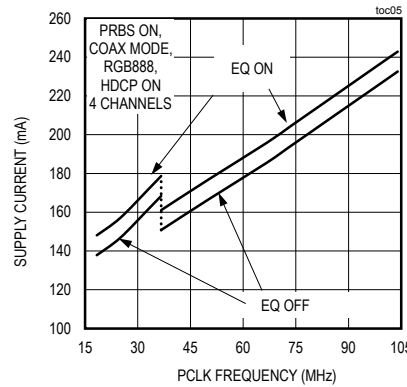

SUPPLY CURRENT vs. PIXEL CLOCK FREQUENCY (BWS = HIGH)

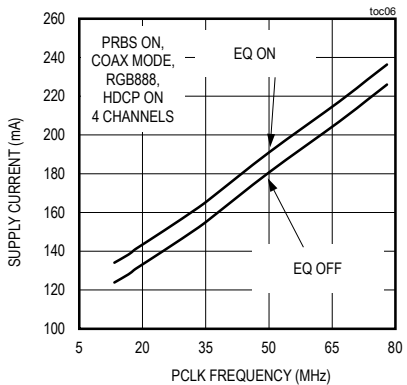

MAXIMUM PIXEL CLOCK FREQUENCY vs. COAX CABLE LENGTH (BER $\leq 10^{-10}$)

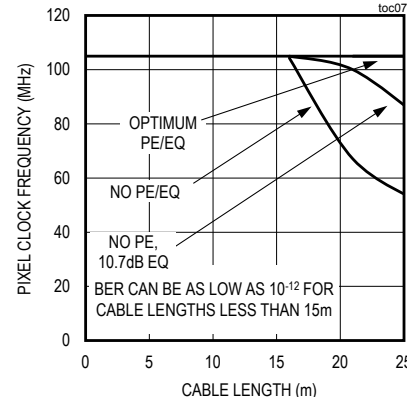

Typical Operating Characteristics (continued)

($V_{AVDD18} = V_{DVDD18} = V_{IOVDD} = 1.8V$, $V_{AVDD3} = 3.3V$, $T_A = +25^\circ C$, unless otherwise noted.)

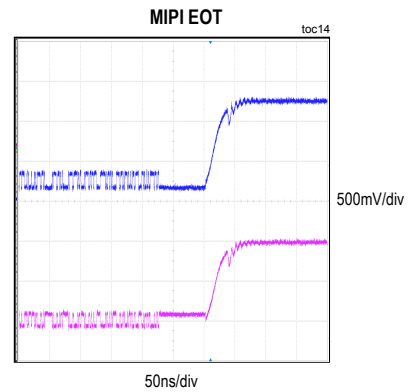
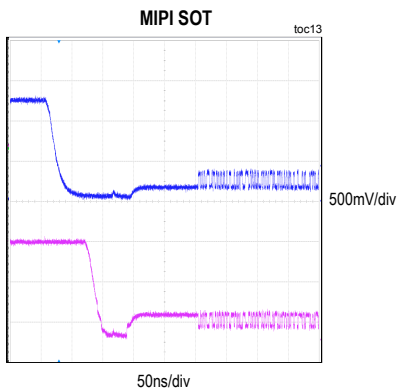
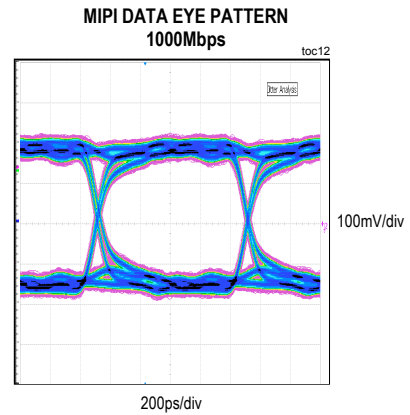
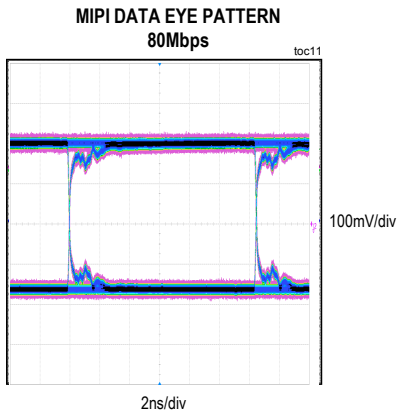
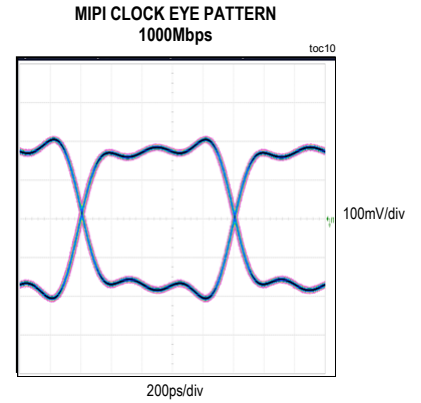
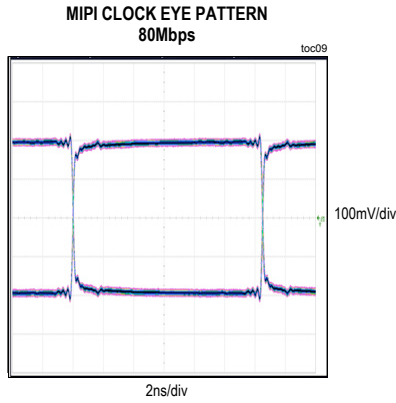
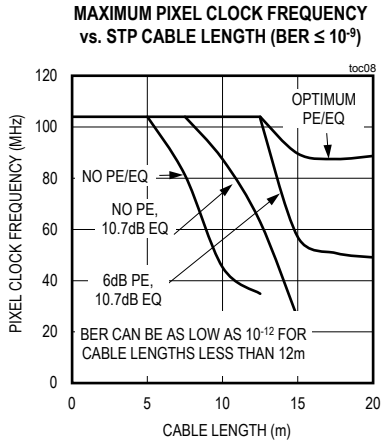

Pin Configuration

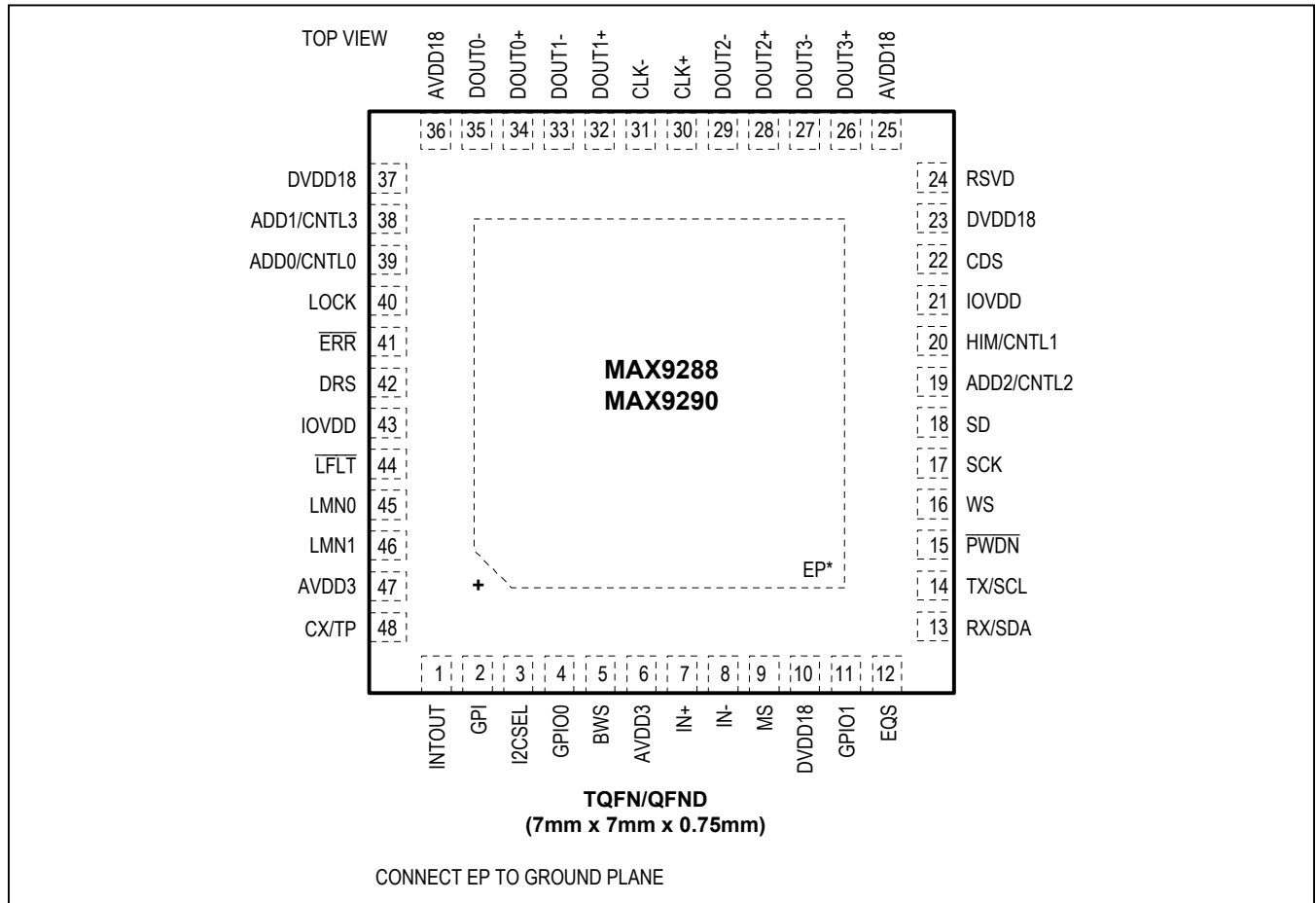

Pin Description

PIN	NAME	FUNCTION
1	INTOUT	A/V Status Register Interrupt Output. Indicates new data in the A/V status registers. INTOUT is reset when the A/V status registers are read.
2	GPI	General-Purpose Input with Internal Pulldown to EP. The serializer GPO (or INT) output follows GPI.
3	I2CSEL	I ² C Select. Control channel interface protocol select input with internal pulldown to EP. Set I2CSEL = high to select I ² C interface. Set I2CSEL = low to select UART interface.
4	GPIO0	Open-Drain, General-Purpose Input/Output, with Internal 60kΩ Pullup to IOVDD
5	BWS	Three-Level Bus Width Select Input. Set BWS to the same level on both sides of the serial link. Set BWS = low, with 6kΩ (max) pulldown for 24-bit mode. Set BWS = high, with 6kΩ (max) pullup to IOVDD for 32-bit mode. Set BWS = open for high-bandwidth mode.
6, 47	AVDD3	3.3V Analog Power Supply. Bypass AVDD3 to EP with 0.1μF and 0.001μF capacitors as close as possible to the device with the smaller capacitor closest to AVDD3.
7	IN+	Noninverting Coax/Twisted-Pair Serial Input
8	IN-	Inverting Coax/Twisted-Pair Serial Input

Pin Description (continued)

PIN	NAME	FUNCTION
9	MS	Mode Select with Internal Pulldown to EP. MS sets the control-link mode when CDS = high. Set MS = low, to select base mode. Set MS = high to select the bypass mode. MS sets autostart mode when CDS = low.
10, 23, 37	DVDD18	1.8V Digital Power Supply. Bypass DVDD18 to EP with 0.1 μ F and 0.001 μ F capacitors as close as possible to the device with the smaller value capacitor closest to DVDD18.
11	GPIO1	Open-Drain, General-Purpose Input/Output, with Internal 60k Ω Pullup to IOVDD
12	EQS	Equalizer Select Input, with Internal Pulldown to EP. The state of EQS latches upon power-up or when resuming from power-down mode ($\overline{\text{PWDN}}$ = low). Leave EQS open for 10.7dB equalizer boost (EQTUNE = 1001). Connect EQS to IOVDD with a 30k Ω resistor for 5.2dB equalizer boost (EQTUNE = 0100).
13	RX/SDA	UART Receive/I ² C Serial Data Input/Output, with Internal 30k Ω Pullup to IOVDD. Function is determined by the state of I2CSEL at power-up. RX/SDA has an open-drain driver and requires a pullup resistor. RX: Input of the deserializer's UART. SDA: Data input/output of the deserializer's I ² C Master/Slave.
14	TX/SCL	UART Transmit/I ² C Serial Clock Input/Output, with Internal 30k Ω Pullup to IOVDD. Function is determined by the state of I2CSEL at power-up. TX/SCL has an open-drain driver and requires a pullup resistor. TX: Output of the deserializer's UART. SCL: Clock input/output of the deserializer's I ² C Master/Slave.
15	$\overline{\text{PWDN}}$	Active-Low, Power-Down Input, with Internal Pulldown to EP. Set $\overline{\text{PWDN}}$ low to enter power-down mode to reduce power consumption.
16	WS	I ² S/TDM Word-Select Input/Output. Powers up as an I ² S output (deserializer provided clock). Set AUDIOMODE bit = '1' to change WS to an input with internal pulldown to GND and supply WS externally (system provided clock).
17	SCK	I ² S/TDM Serial-Clock Input/Output. Powers up as an I ² S output (deserializer provided clock). Set AUDIOMODE bit = '1' to change SCK to an input with internal pulldown to GND and supply SCK externally (system provided clock).
18	SD	I ² S/TDM Serial-Data Output. Disable I ² S/TDM encoding to serial data to use SD as an additional control/data output. Encrypted when HDCP is enabled.
19	ADD2/CNTL2	Address Selection Input/Auxiliary Control Signal Output, with Internal Pulldown to EP. Functions as ADD2 input at power-up or when resuming from power-down mode ($\overline{\text{PWDN}}$ = low), and switches to CNTL2 output automatically after power-up. ADD2: Bit value is latched at power-up or when resuming from power-down mode ($\overline{\text{PWDN}}$ = low). See Table 1. Connect ADD2/CNTL2 to IOVDD with a 30k Ω resistor to set high or leave open to set low. CNTL2: Used only in 32-bit and high-bandwidth mode (BWS = high, open). CNTL2 is mapped from the GMSL serializer's CNTL2 or DIN28 input.

Pin Description (continued)

PIN	NAME	FUNCTION
20	HIM/CNTL1	<p>High-Immunity Mode Input/Auxiliary Control Signal Output With Internal Pulldown to EP. Functions as HIM input at power-up or when resuming from power-down mode ($\overline{\text{PWDN}} = \text{low}$), and switches to CNTL2 output automatically after power-up.</p> <p>HIM: Default HIGHIMM bit value is latched at power-up or when resuming from power-down mode ($\overline{\text{PWDN}} = \text{low}$) and is active-high. Connect HIM/CNTL1 to IOVDD with a 30kΩ resistor to set high or leave open to set low. HIGHIMM can be programmed to a different value after power-up. HIGHIMM in the serializer must be set to the same value.</p> <p>CNTL1: Used only in 32-bit and high-bandwidth mode (BWS = high, open). CNTL1 is mapped from the GMSL serializer's CNTL1, DIN27, or RES input.</p>
21, 43	IOVDD	I/O Supply Voltage. 1.8V to 3.3V logic I/O power supply. Bypass IOVDD to EP with 0.1 μF and 0.001 μF capacitors as close as possible to the device with the smallest value capacitor closest to IOVDD.
22	CDS	Control Direction Selection Input, with Internal Pulldown to EP. Control link direct selection input with internal pulldown to EP. Set CDS = low when the control channel master μC is connected at the serializer. Set CDS = high when the control channel master μC is connected at the deserializer.
24	RES	Reserved. Leave unconnected
25, 36	AVDD18	1.8V Analog Power Supply. Bypass AVDD18 to EP with 0.1 μF and 0.001 μF capacitors as close as possible to the device with the smaller capacitor closest to AVDD18.
26–29, 32–35	DOUT_+, DOUT_-	CSI-2 Data Outputs
30, 31	CLK+, CLK-	CSI-2 Clock Output
38	ADD1/CNTL3	<p>Auxiliary Control Signal Output/Address Selection Input, with Internal Pulldown to EP. Functions as ADD1 input at power-up or when resuming from power-down mode ($\overline{\text{PWDN}} = \text{low}$), and switches to CNTL3 output automatically after power-up.</p> <p>ADD1: Bit value is latched at power-up or when resuming from power-down mode ($\overline{\text{PWDN}} = \text{low}$). See Table 1. Connect ADD1/CNTL3 to IOVDD with a 30kΩ resistor to set high or leave open to set low.</p> <p>CNTL3: Used only in high-bandwidth mode (BWS = open).</p>
39	ADD0/CNTL0	<p>Auxiliary Control Signal Output/Address Selection Input, with Internal Pulldown to EP. Functions as ADD0 input at power-up or when resuming from power-down mode ($\overline{\text{PWDN}} = \text{low}$), and switches to CNTL0 output automatically after power-up.</p> <p>ADD0: Bit value is latched at power-up or when resuming from power-down mode ($\overline{\text{PWDN}} = \text{low}$). See Table 1. Connect ADD0/CNTL0 to IOVDD with a 30kΩ resistor to set high or leave open to set low.</p> <p>CNTL0: Used only in high-bandwidth mode (BWS = open).</p>
40	LOCK	Open-Drain Lock Output, with Internal 60k Ω Pullup to IOVDD. LOCK = high indicates that PLLs are locked with correct serial-word-boundary alignment. LOCK = low indicates that PLLs are not locked or an incorrect serial-word-boundary alignment. LOCK is high when $\overline{\text{PWDN}} = \text{low}$.
41	$\overline{\text{ERR}}$	Error Output. Open-drain data error detection and/or correction indication output with internal 60k Ω pullup to IOVDD. $\overline{\text{ERR}}$ is high when $\overline{\text{PWDN}}$ is low.

Pin Description (continued)

PIN	NAME	FUNCTION
42	DRS	Data-Rate Select Input. DRS is latched upon power-up or when PWDN transitions low-to-high. Set DRS high for pixel clock rates below 16.66MHz (BWS = low), 12.5MHz (BWS = high), or 36.66MHz (BWS = open). Set DRS = low for faster pixel clock rates.
44	LFLT	Active-Low Open-Drain Line-Fault Output. LFLT has a 60kΩ internal pullup to IOVDD. LFLT = low indicates a line fault. LFLT is high when PWDN = low.
45	LMN0	Line Fault Monitor Input 0 (See Figure 1)
46	LMN1	Line Fault Monitor Input 1 (See Figure 1)
48	CX/TP	Three-Level Coax/Twisted Pair Select Input. Use 6kΩ (max) pullup to IOVDD or pulldown resistor for setting CX/TP = high or low. See Table 12 for function.
—	EP	Exposed Pad. EP is internally connected to device ground. MUST connect EP to the PCB ground plane through an array of vias for proper thermal and electrical performance.

Functional Diagram

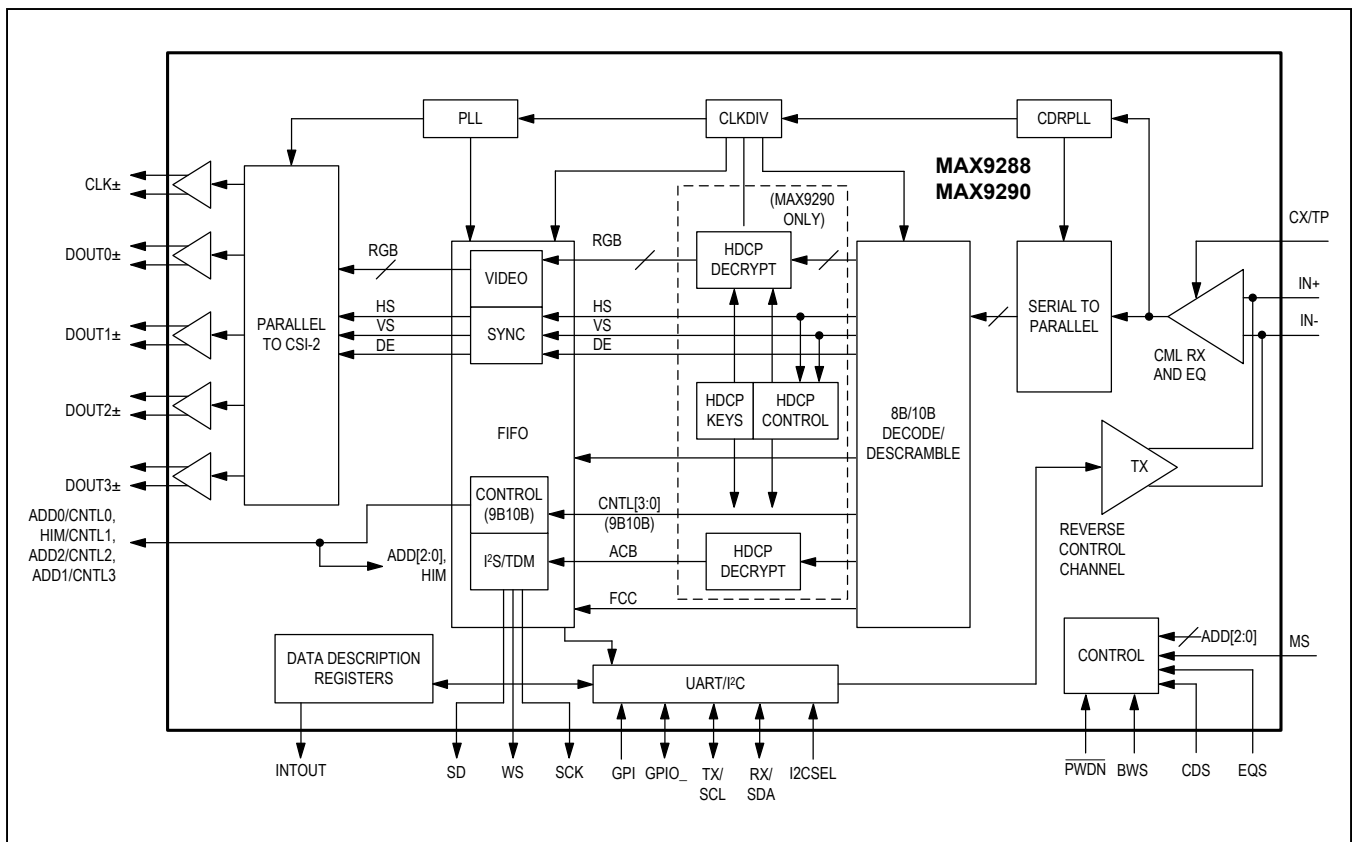

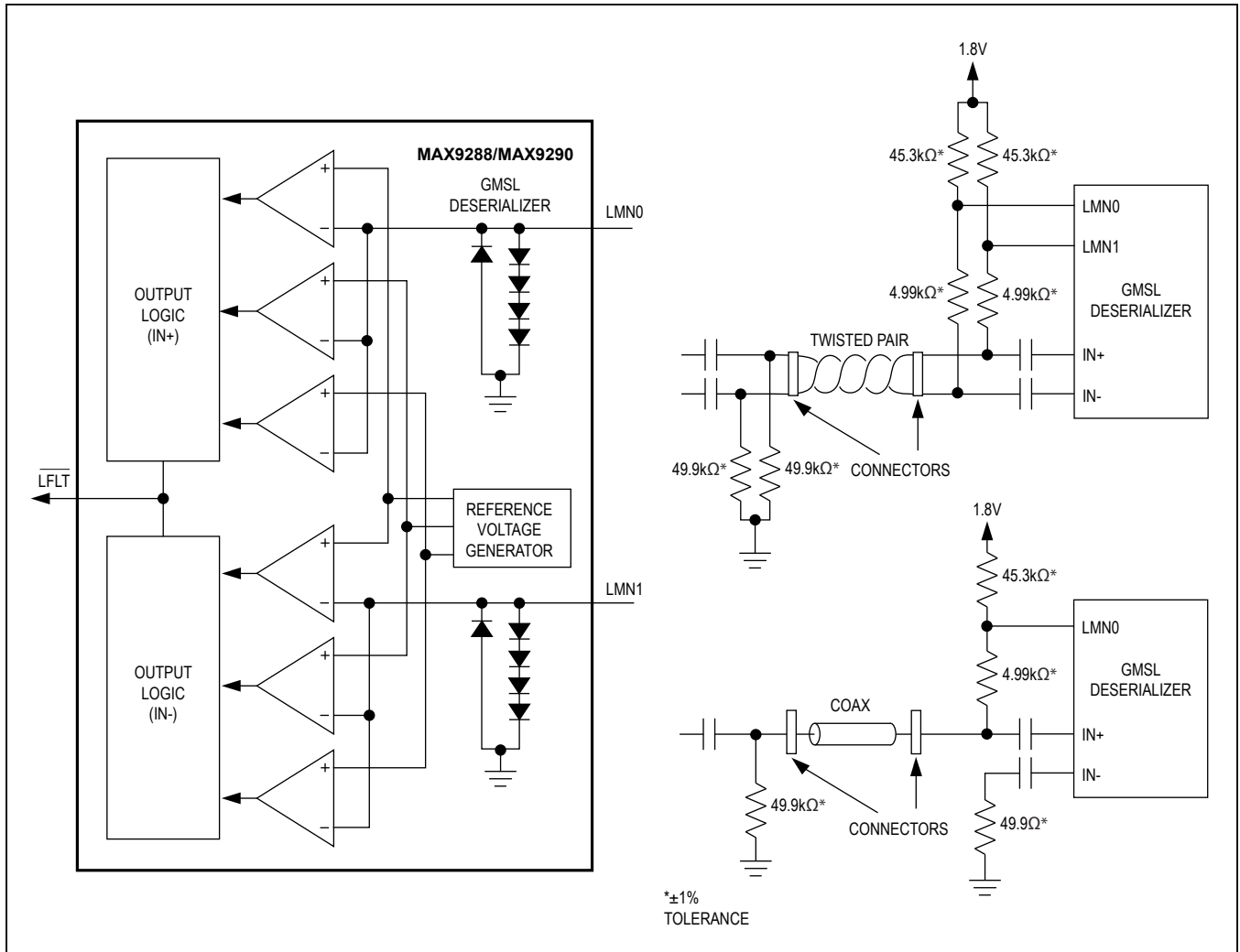

Figure 1. Line Fault

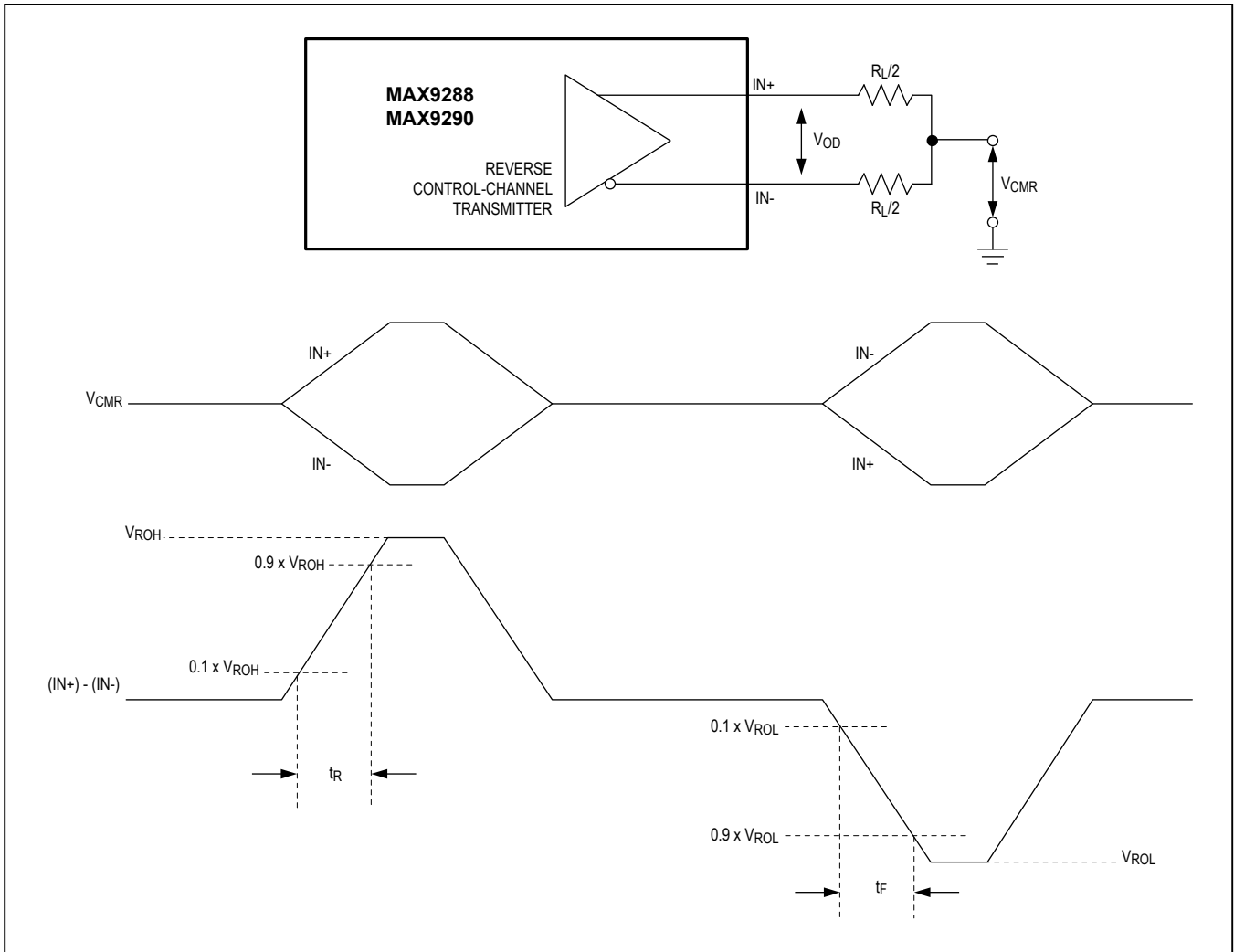

Figure 2. Reverse Control-Channel Output Parameters

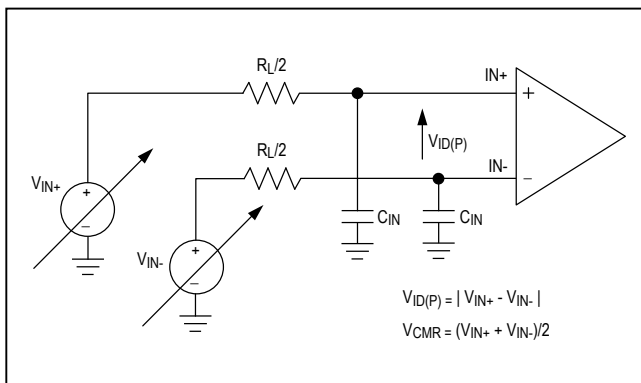

Figure 3. Test Circuit for Differential Input Measurement

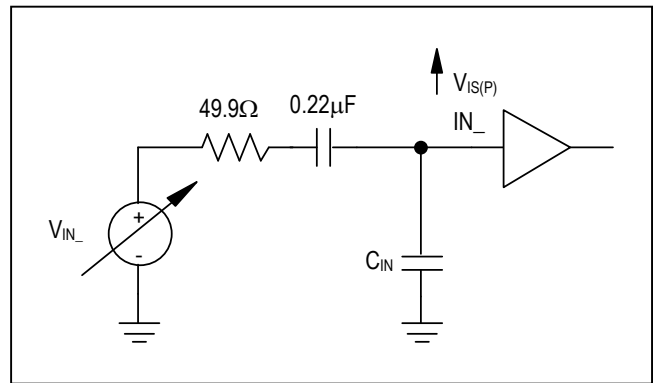

Figure 4. Test Circuit for Single-Ended Input Measurement

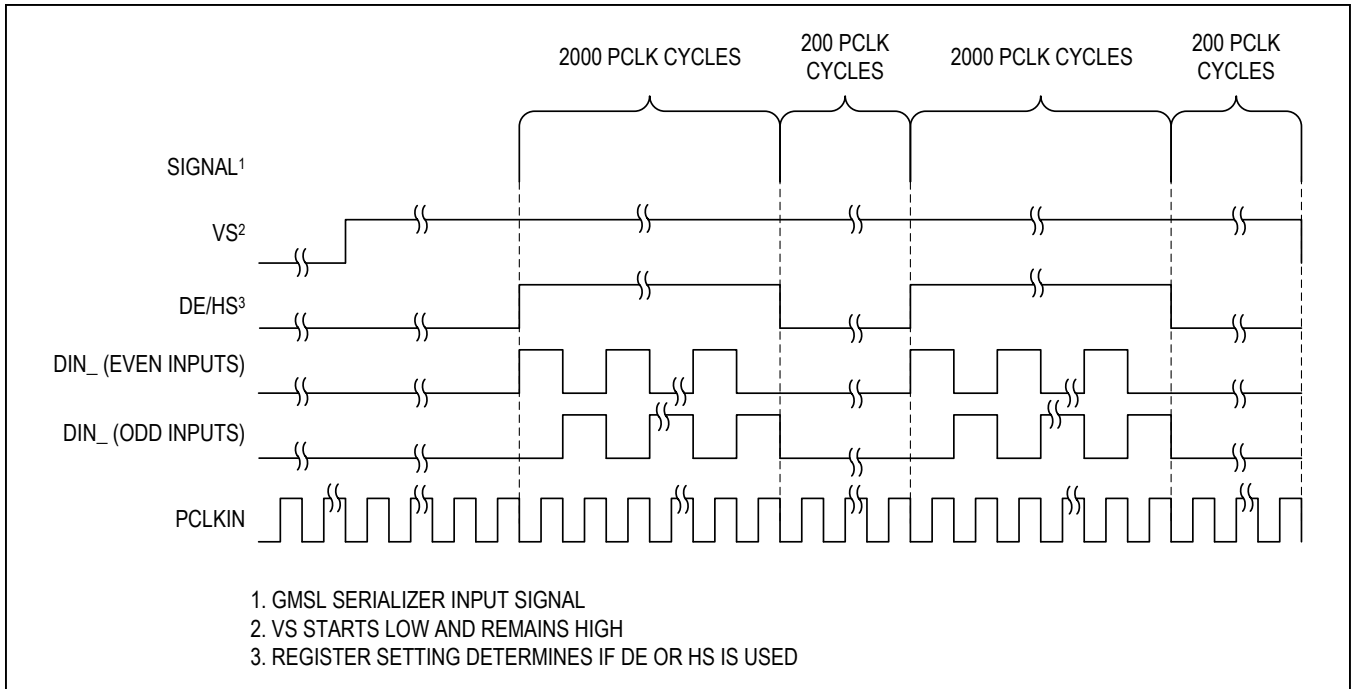

Figure 5. Worst-Case Pattern Output

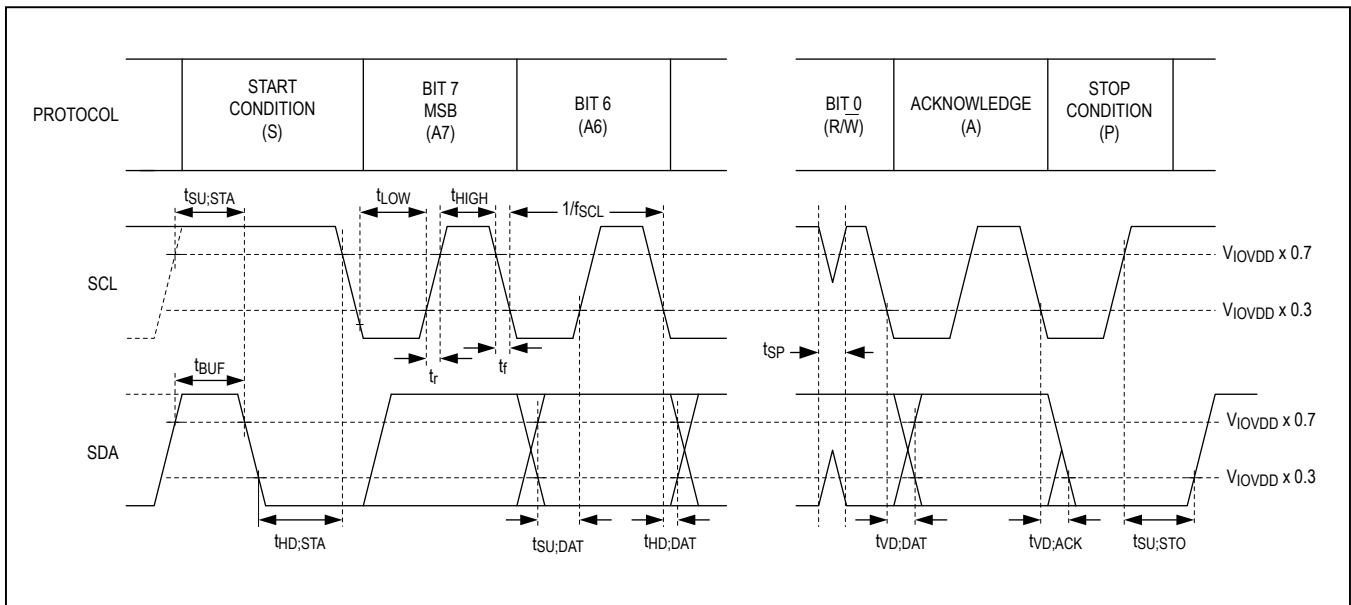

Figure 6. I²C Timing Parameters

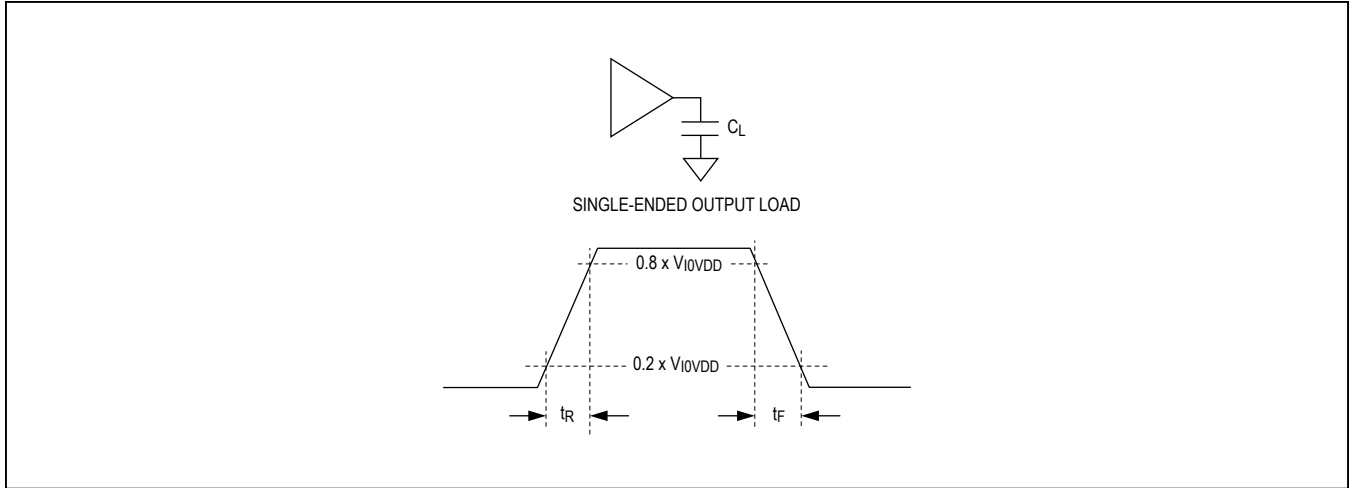

Figure 7. Output Rise-and-Fall Times

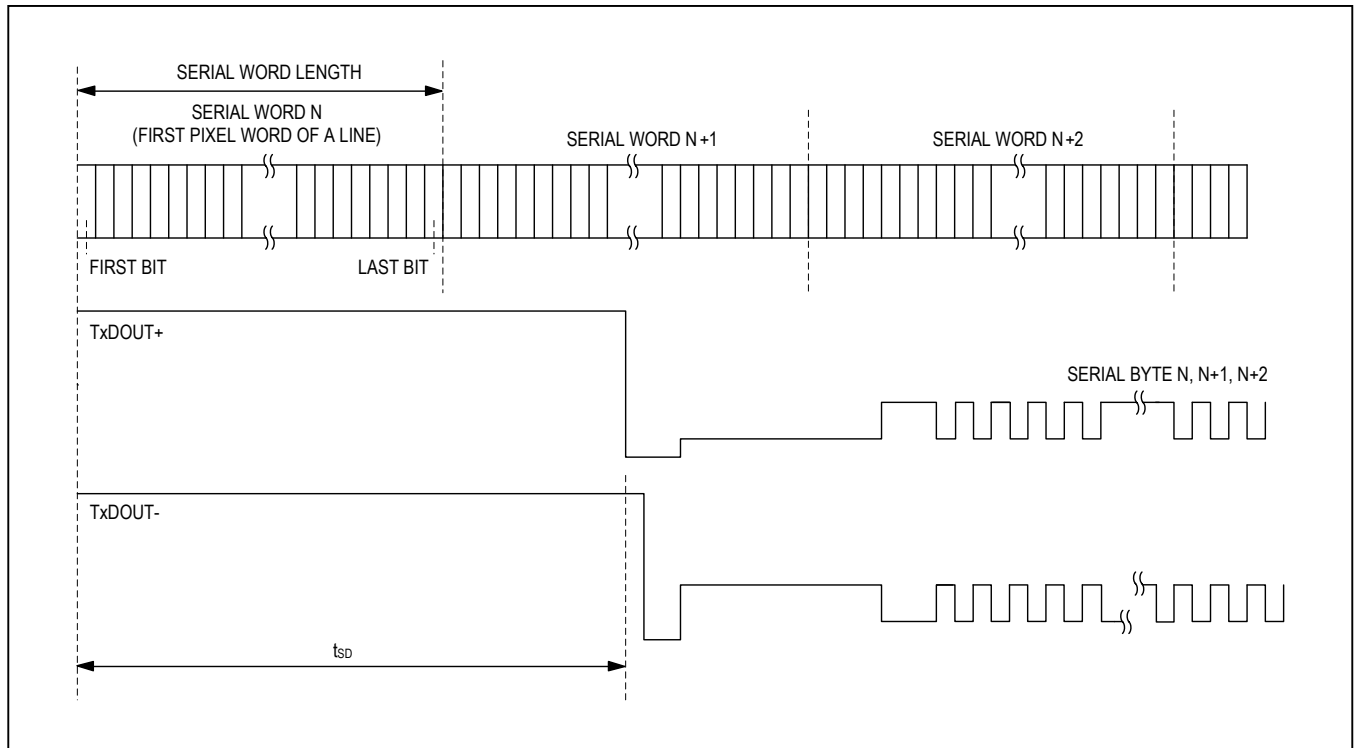

Figure 8. Deserializer Delay

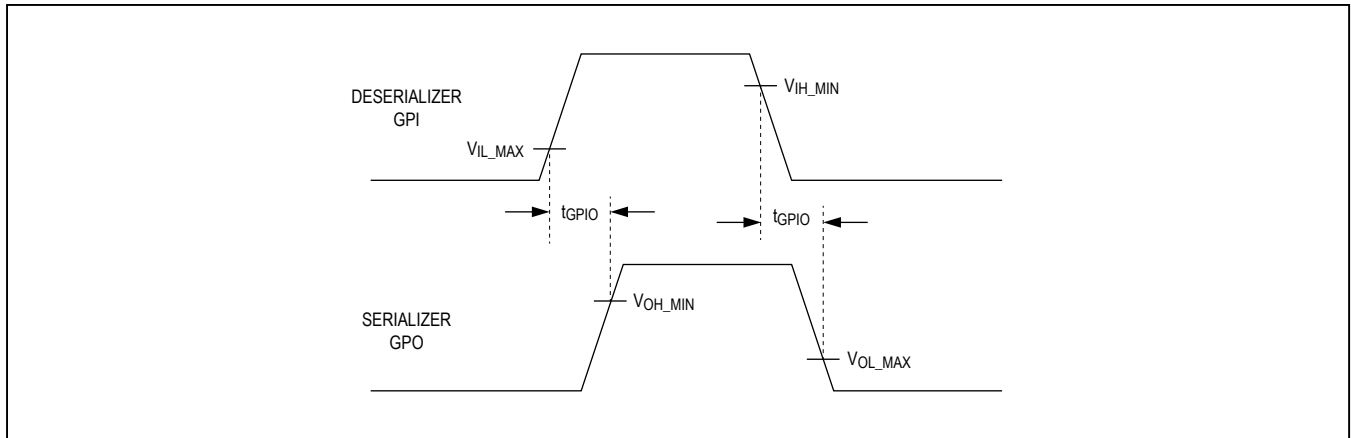

Figure 9. GPI-to-GPO Delay

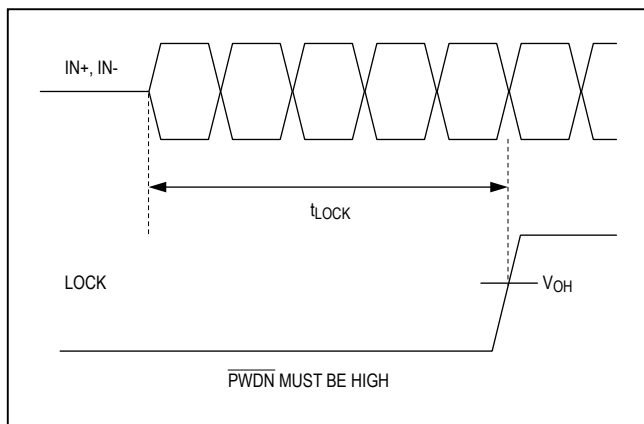

Figure 10. Lock Time

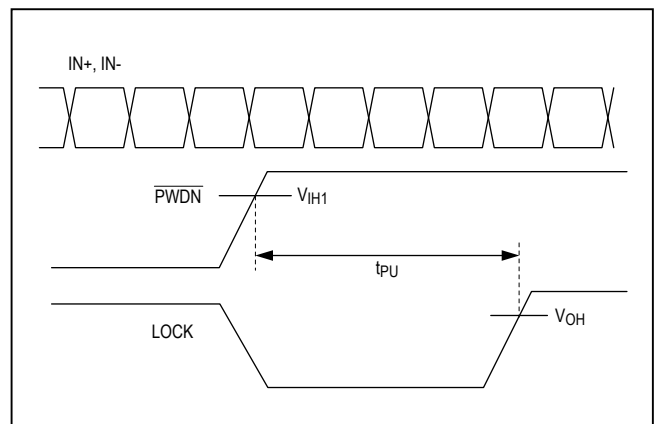

Figure 11. Power-Up Delay

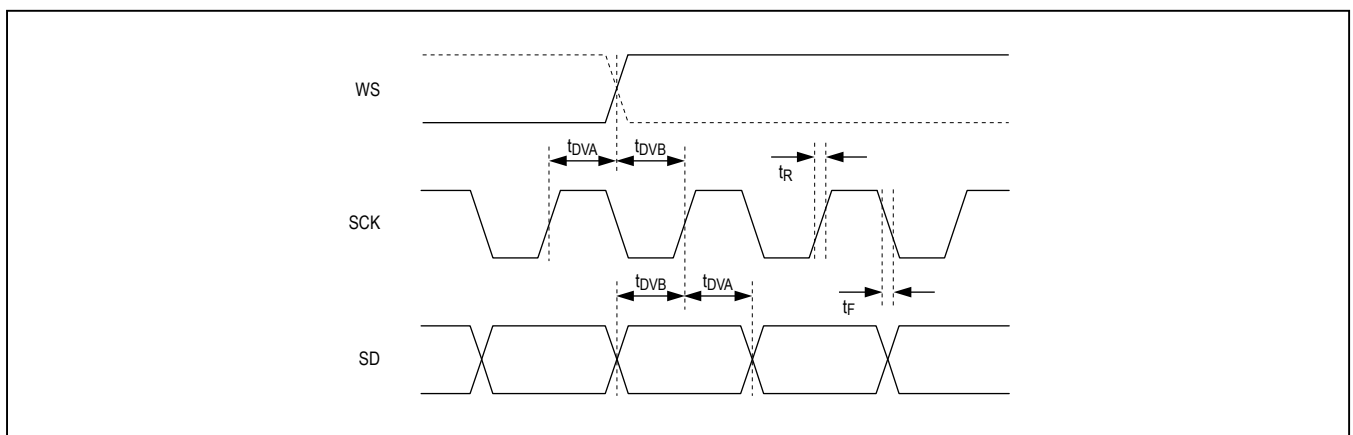

Figure 12. Output I2S Timing Parameters

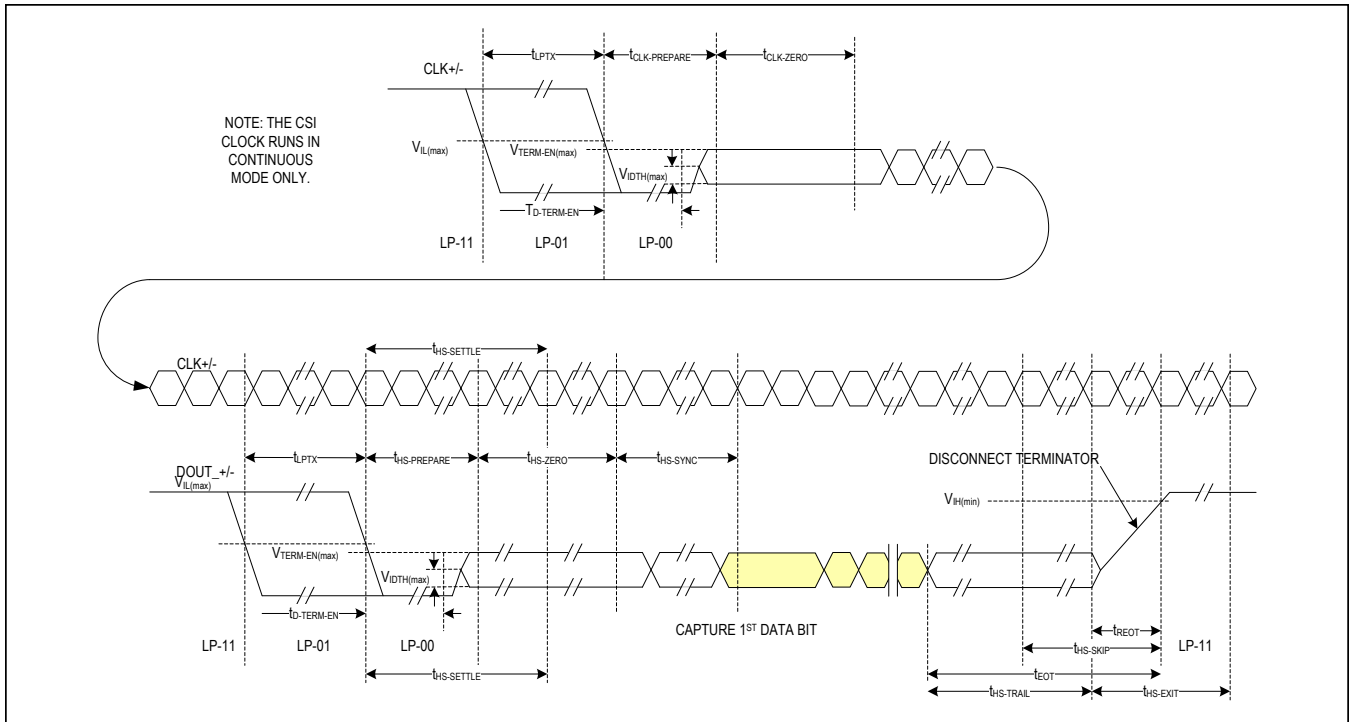

Figure 13. MIPI Output Timing Parameters

Detailed Description

The MAX9288/MAX9290 deserializers, when paired with the MAX9275/MAX9277/MAX9279/MAX9281 serializers, provide the full set of operating features, but are backward-compatible with the MAX9249–MAX9270 family of gigabit multimedia serial link (GMSL) devices, and have basic functionality when paired with any GMSL device. The MAX9290 has high-bandwidth digital content protection (HDCP), while the MAX9288 does not.

Each deserializer has a maximum serial-bit rate of 3.12Gbps for up to 15m of cable and operates up to a maximum output clock of 104MHz in 24-bit mode and 27-bit high-bandwidth mode, or 78MHz in 32-bit mode. This bit rate and output flexibility support a wide range of displays, from QVGA (320 x 240) to 1920 x 720 and higher with 24-bit color, as well as megapixel image sensors. An encoded audio channel supports L-PCM I2S stereo and up to eight channels of L-PCM in TDM mode. Sample rates of 32kHz to 192kHz are supported with sample depth from 8 to 32 bits. Input equalization, combined with GMSL serializer pre/deemphasis, extends the cable length and enhances link reliability.

The control channel enables a μ C to program the serializer and deserializer registers and program registers on peripherals. The control channel is also used to perform HDCP functions (MAX9290 only). The μ C can be located at either end of the link, or when using two μ Cs, at both ends. Two modes of control-channel operation are available. Base mode uses either I2C or GMSL UART protocol, while bypass mode uses a user-defined UART protocol. UART protocol allows full-duplex communication, while I2C allows half-duplex communication.

The serial input complies with ISO 10605 and IEC 61000-4-2 ESD protection standards.

Register Mapping

Registers set the operating conditions of the deserializers and are programmed using the control channel in base mode. The MAX9288/MAX9290 holds its own device address and the device address of the serializer it is paired with. Similarly, the serializer holds its own device address and the address of the MAX9288/MAX9290. Whenever a device address is changed, be sure to write the new address to both devices. The default device address of the deserializer is set by the ADD_ and CX/TP inputs (Table 1). Registers 0x00 and 0x01 in both devices hold the device addresses.

Table 1. Device Address Defaults (Register 0x00, 0x01)

PIN				DEVICE ADDRESS (BIN)								SERIALIZER DEVICE ADDRESS (hex)	DESERIALIZER DEVICE ADDRESS (hex)
CX/TP	ADD2	ADD1	ADD0	D7	D6	D5	D4	D3	D2	D1	D0		
High/Low	Low	Low	Low	1	0	0	X*	0	0	0	R/W	80	90
High/Low	Low	Low	High	1	0	0	X*	0	1	0	R/W	84	94
High/Low	Low	High	Low	1	0	0	X*	1	0	0	R/W	88	98
High/Low	Low	High	High	0	1	0	X*	0	1	0	R/W	44	54
High/Low	High	Low	Low	1	1	0	X*	0	0	0	R/W	C0	D0
High/Low	High	Low	High	1	1	0	X*	0	1	0	R/W	C4	D4
High/Low	High	High	Low	1	1	0	X*	1	0	0	R/W	C8	D8
High/Low	High	High	High	0	1	0	X*	1	0	0	R/W	48	58
Open**	Low	Low	Low	1	0	0	X*	0	0	X*	R/W	80	92
Open**	Low	Low	High	1	0	0	X*	0	1	X*	R/W	84	96
Open**	Low	High	Low	1	0	0	X*	1	0	X*	R/W	88	9A
Open**	Low	High	High	0	1	0	X*	0	1	X*	R/W	44	56
Open**	High	Low	Low	1	1	0	X*	0	0	X*	R/W	C0	D2
Open**	High	Low	High	1	1	0	X*	0	1	X*	R/W	C4	D6
Open**	High	High	Low	1	1	0	X*	1	0	X*	R/W	C8	DA
Open**	High	High	High	0	1	0	X*	1	0	X*	R/W	48	5A

*X = 0 for the serializer address, X = 1 for the deserializer address.

**CX/TP determine the serial-cable type CX/TP = open addresses only for coax mode.

Output Bit Map

The input/output bit width depends on settings of the bus width pin (BWS) and the CSI-2 output mode. [Table 4](#) and [Table 3](#) list the bit map for video signals. [Table 4](#) lists the bit map for control signals. Unused control output bits are pulled low.

Serial Link Signaling and Data Format

The serializer uses differential CML signaling to drive twisted-pair cable and single-ended CML to drive coaxial cable with programmable pre/deemphasis and AC-coupling. The deserializer uses AC-coupling and programmable channel equalization.

Input data is scrambled and then 8b/10b coded (9b/10b in high-bandwidth mode). The deserializer recovers the embedded serial clock, then samples, decodes, and descrambles the data. In 24-bit mode, the first 21 bits contain 18 bits of video data and 3 bits of control data (HS/VS/DE). In 32-bit mode, the first 29 bits contain 24 bits of video data, 3 bits of control data (HS/VS/DE) and two bits of control data (CNTL1/CNTL2). In high-bandwidth mode, the first 24 bits contain video data, or

special control-signal packets. In all modes, the last 3 bits contain the embedded audio channel, the embedded forward control channel, and the parity bit of the serial word ([Figure 14](#), [Figure 15](#), [Figure 16](#)).

GMSL-to-CSI-2 Conversion and Output

The GMSL deserializer recovers the clock from the serialized input signals and extracts the video, audio, and control. Video data are packetized to according to MIPI CSI-2 packet formats and sent out through the MIPI DPHY serial lanes.

Video Data Operation

The device converts the video control signal VS to the CSI-2 Frame Start or Frame End short packet ([Figure 17](#)). The converter also assembles the pixel color data into the CSI-2 long packets based on the formats and/or pixel count programmed by the user ([Figure 18](#), [Figure 19](#), [Figure 20](#), [Figure 21](#), [Figure 22](#), [Figure 23](#), [Figure 24](#), [Figure 25](#), [Figure 26](#), [Figure 27](#), [Figure 28](#), [Figure 29](#), [Figure 30](#), and [Figure 31](#)). DE low period needs to be a minimum 200 PCLK cycles to accommodate SOT and EOT during the DE blanking period.

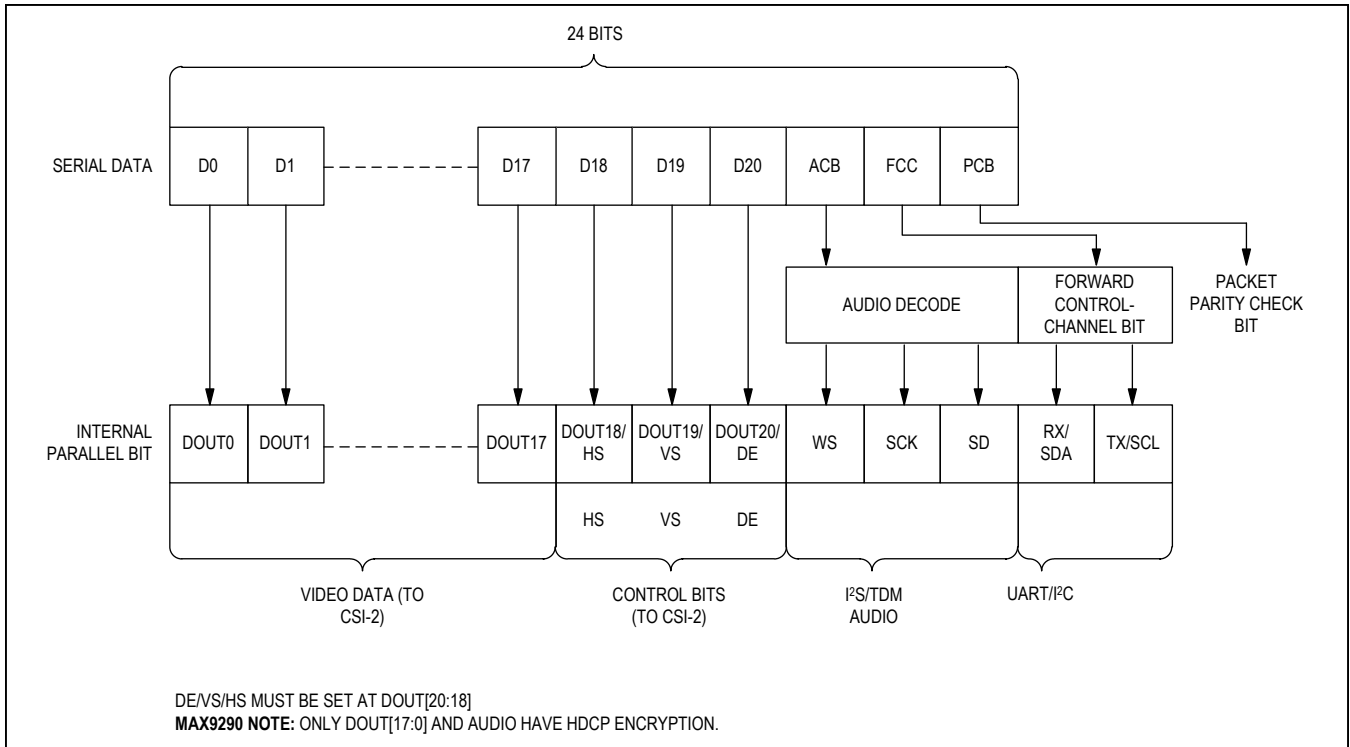

Figure 14. 24-Bit Mode Serial Data Format

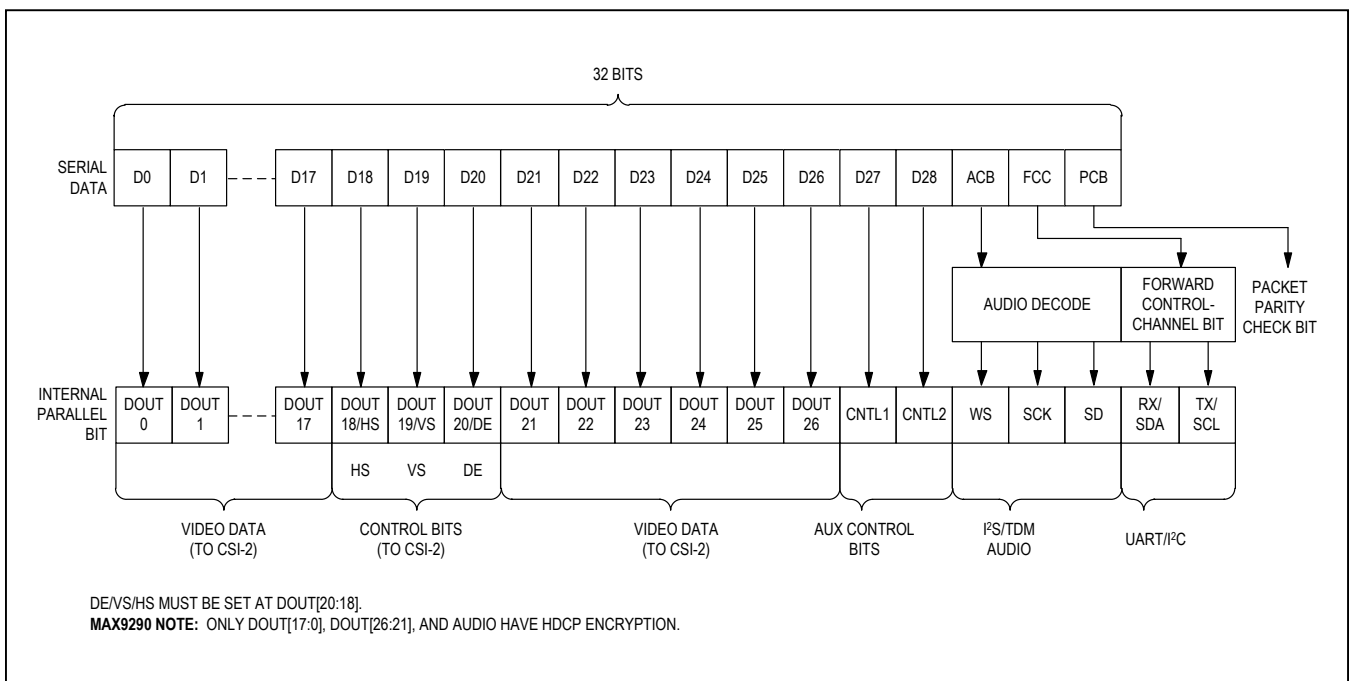

Figure 15. 32-Bit Mode Serial Data Format

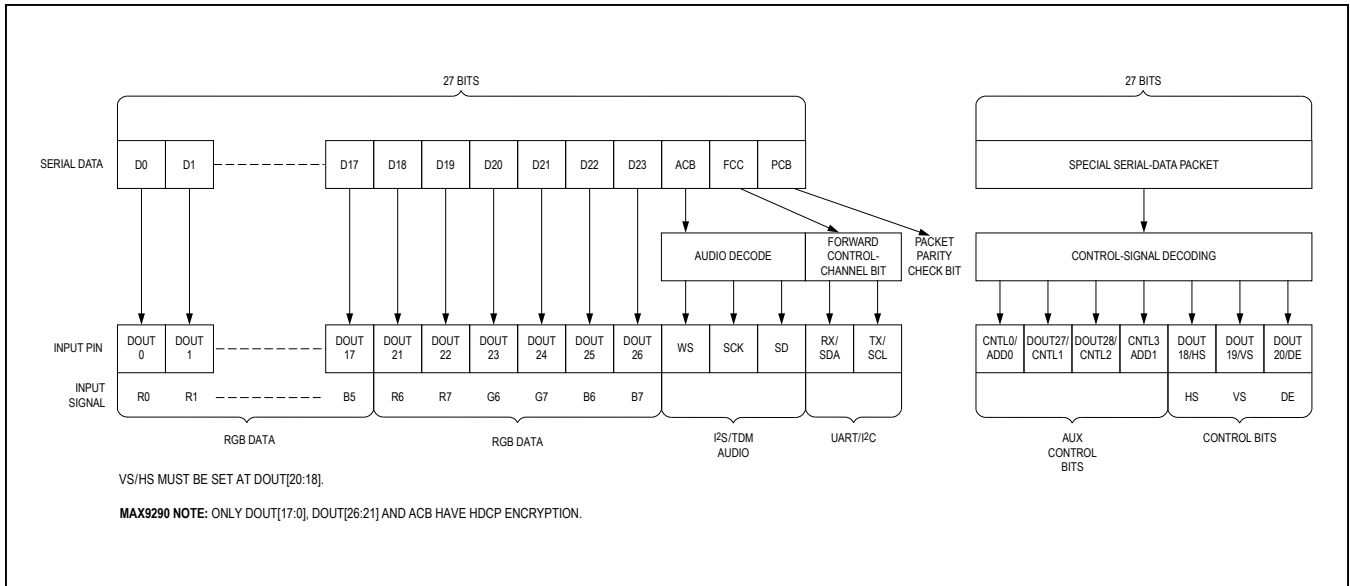

Figure 16. High-Bandwidth Mode Serial-Data Format

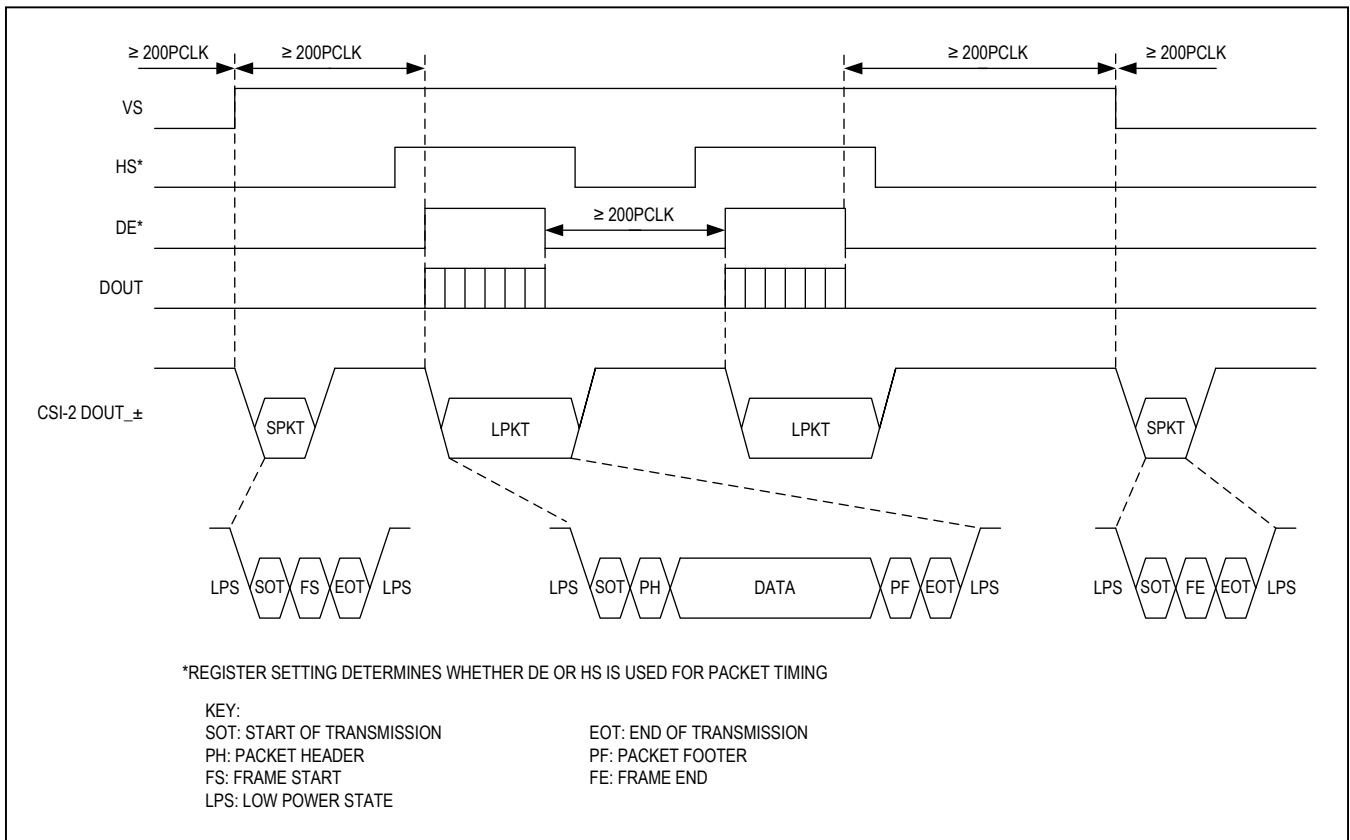

Figure 17. Transmitting a Frame from GMSL to MIPI

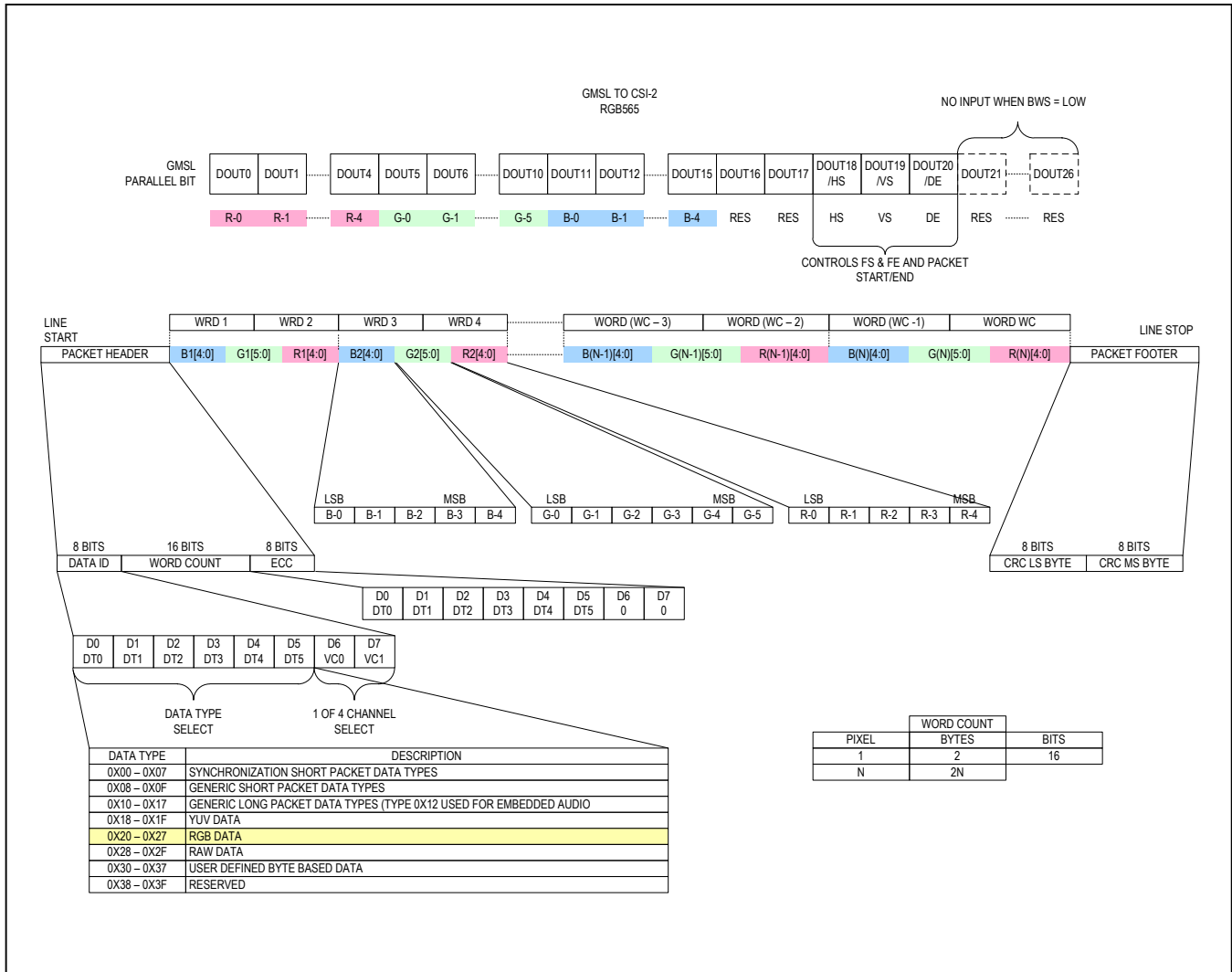

Figure 18. RGB565 Output

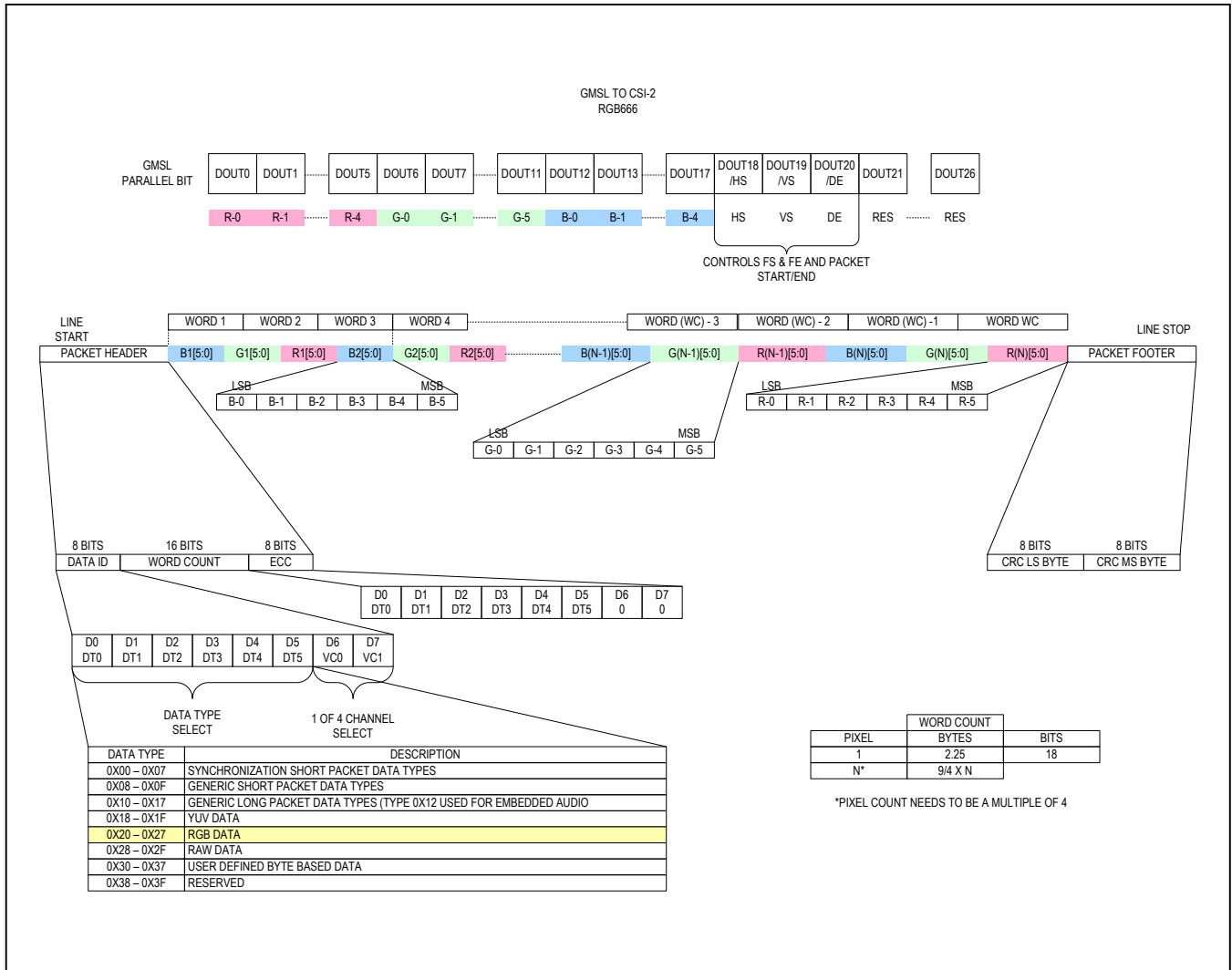

Figure 19. RGB666 Output

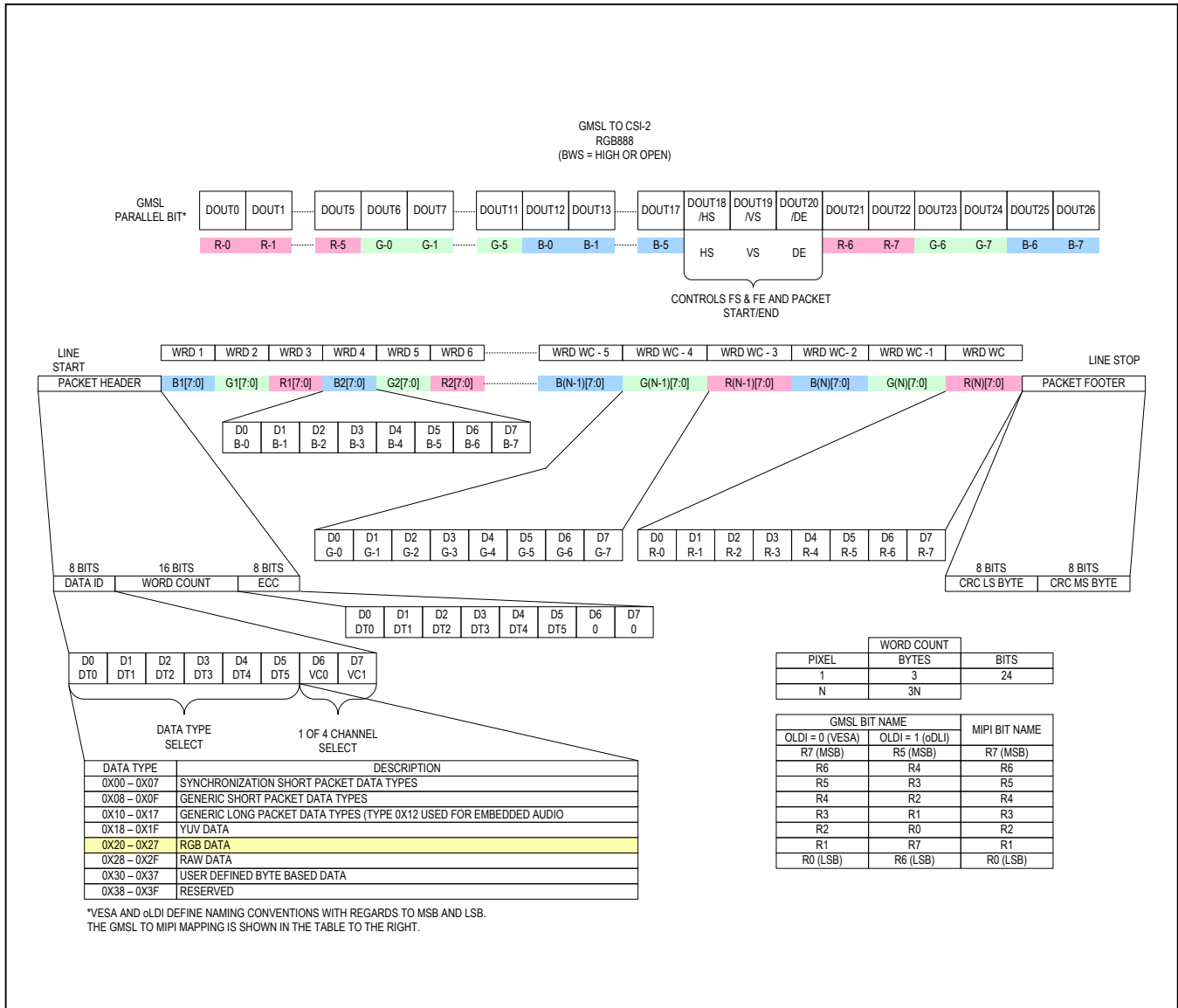

Figure 20. RGB888 Output

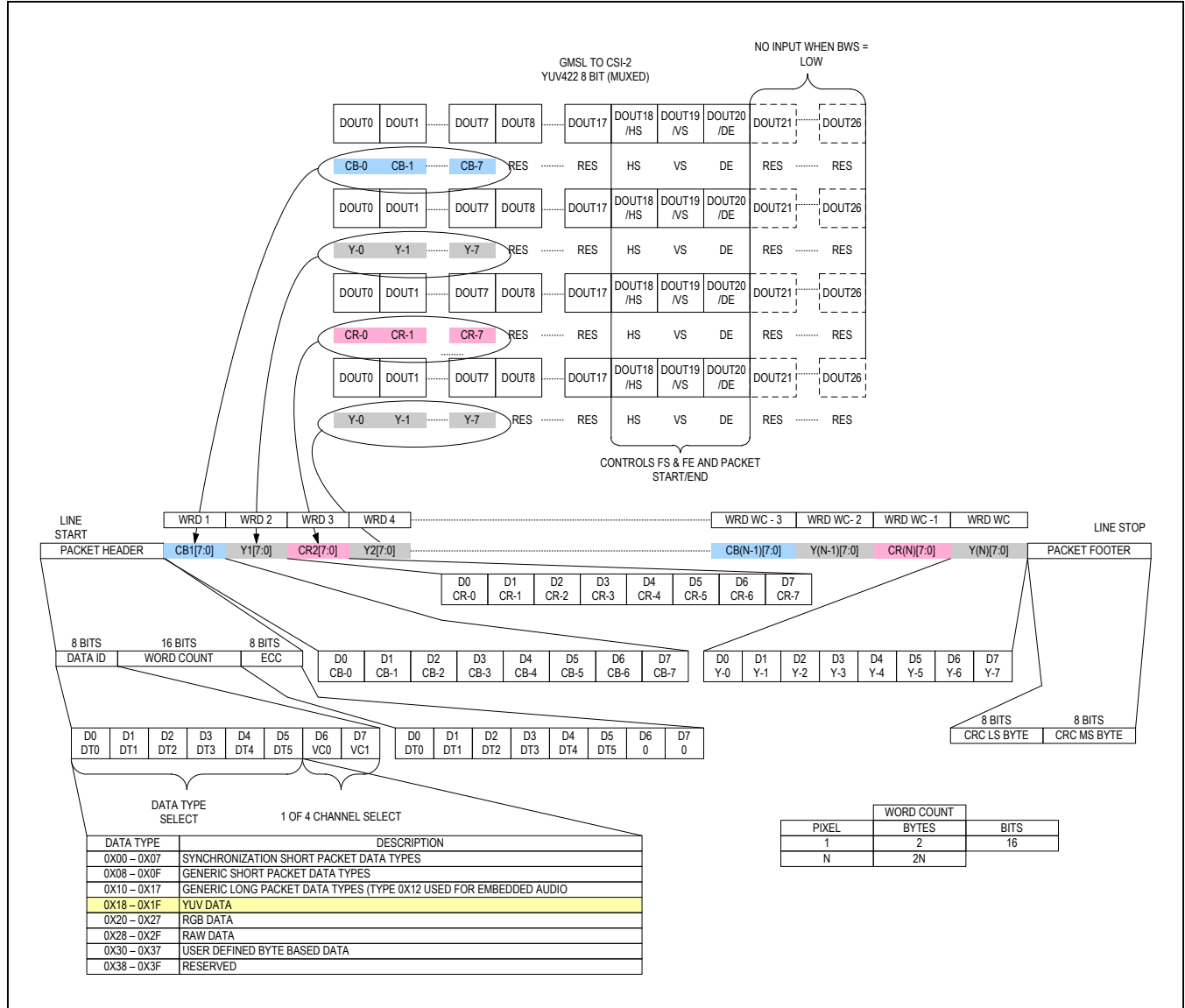

Figure 21. YUV422 8-Bit (Muxed) Output

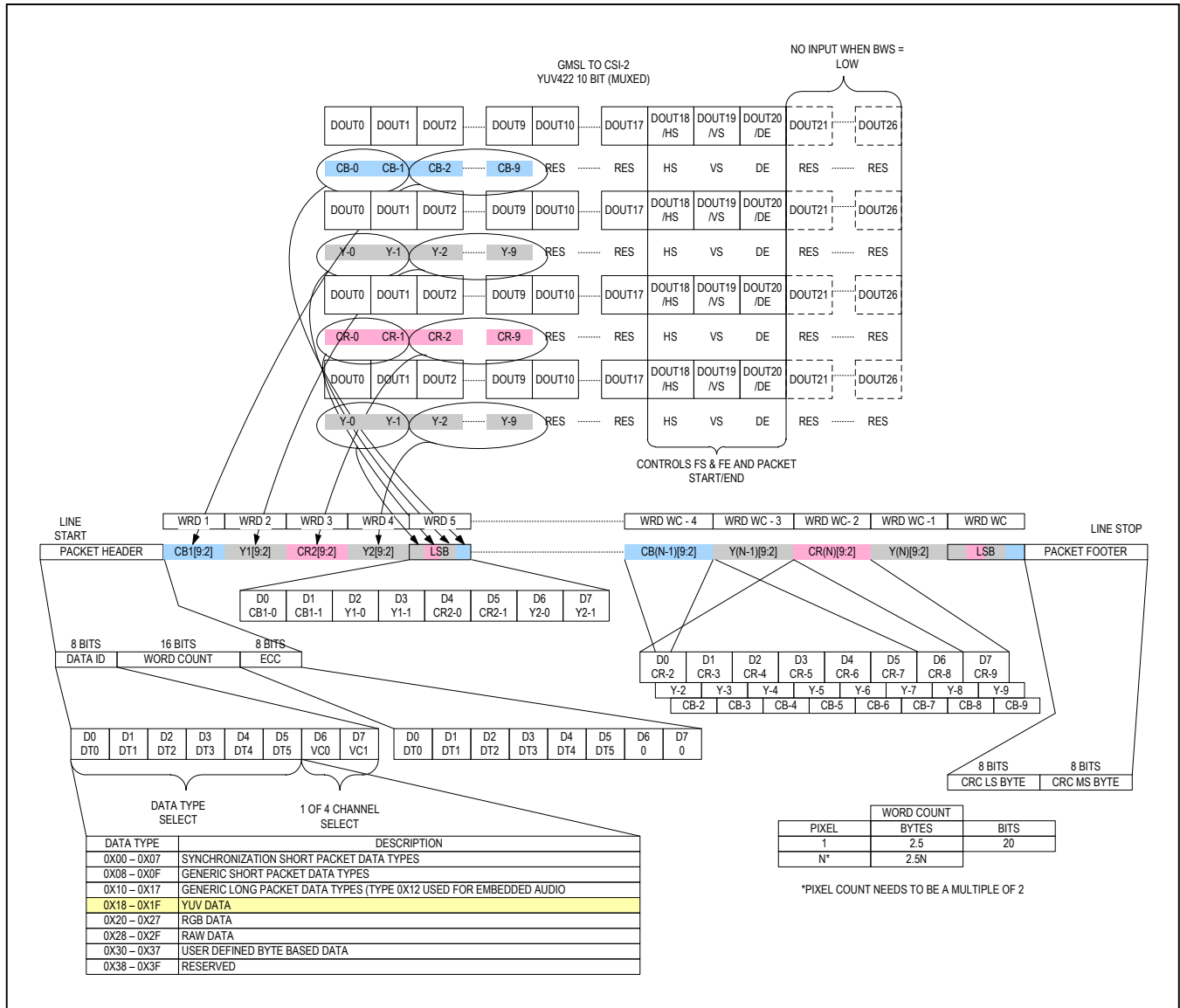

Figure 22. YUV422 10-Bit (Muxed) Output

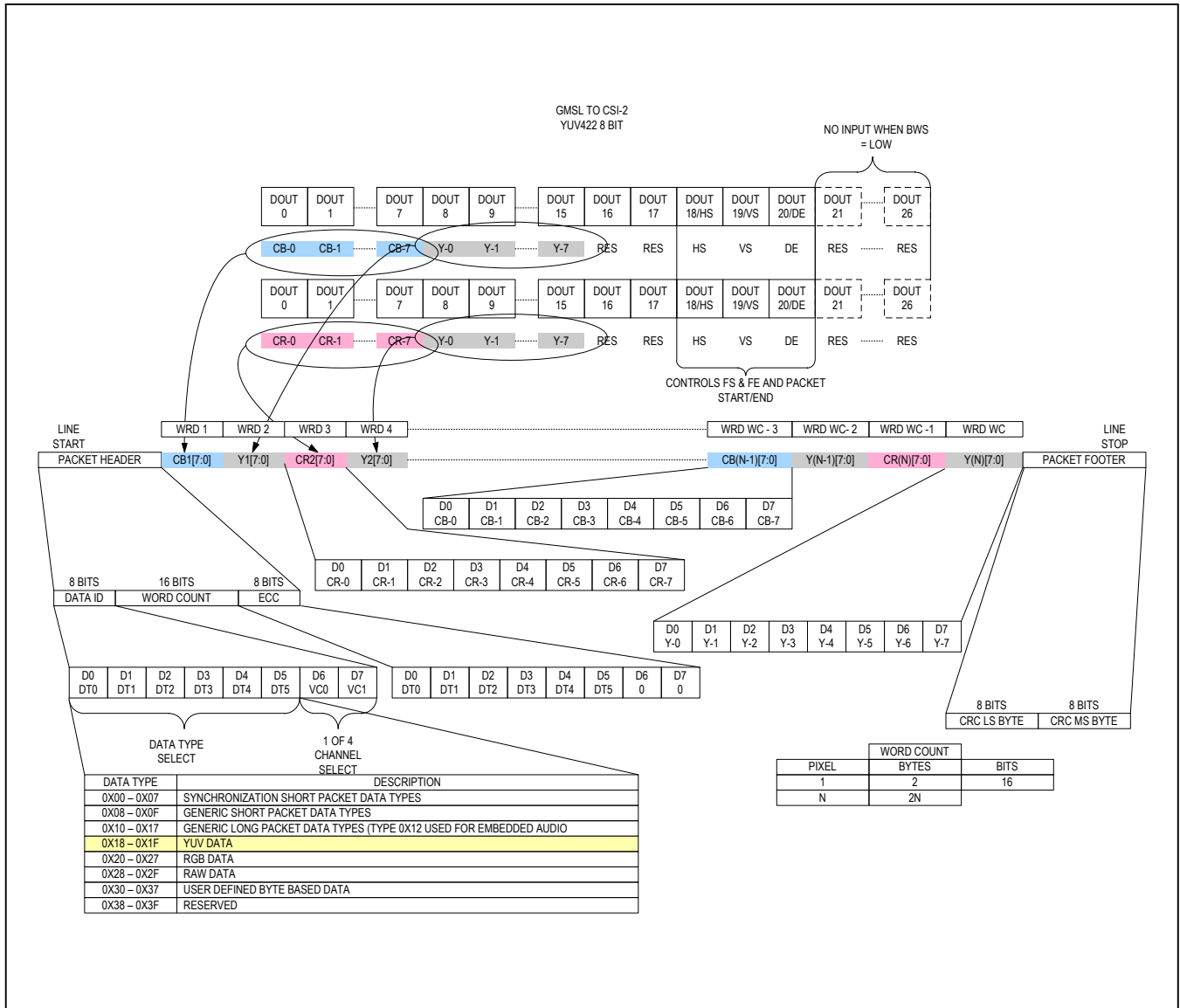

Figure 23. YUV422 8-Bit Output

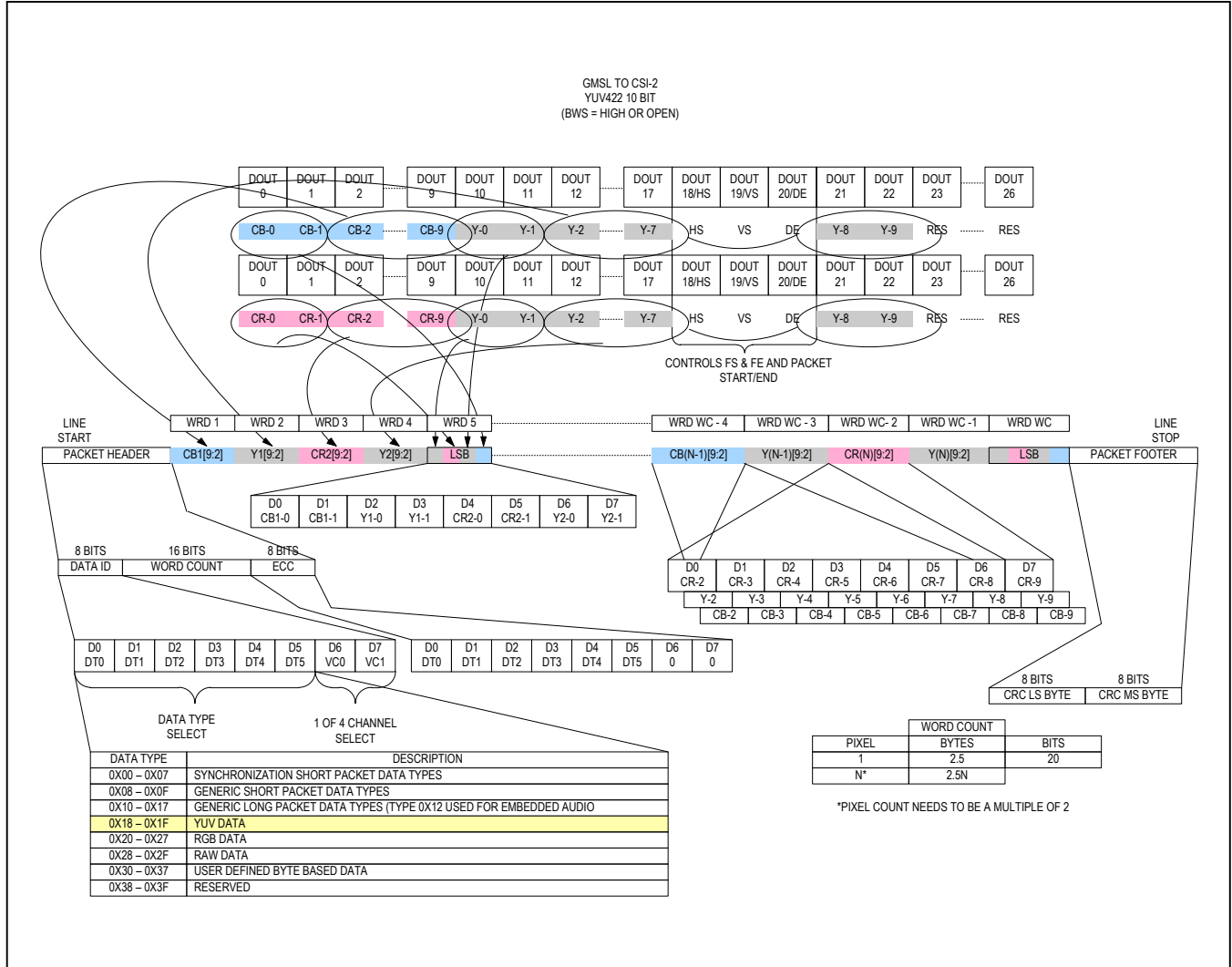

Figure 24. YUV422 10-Bit Output

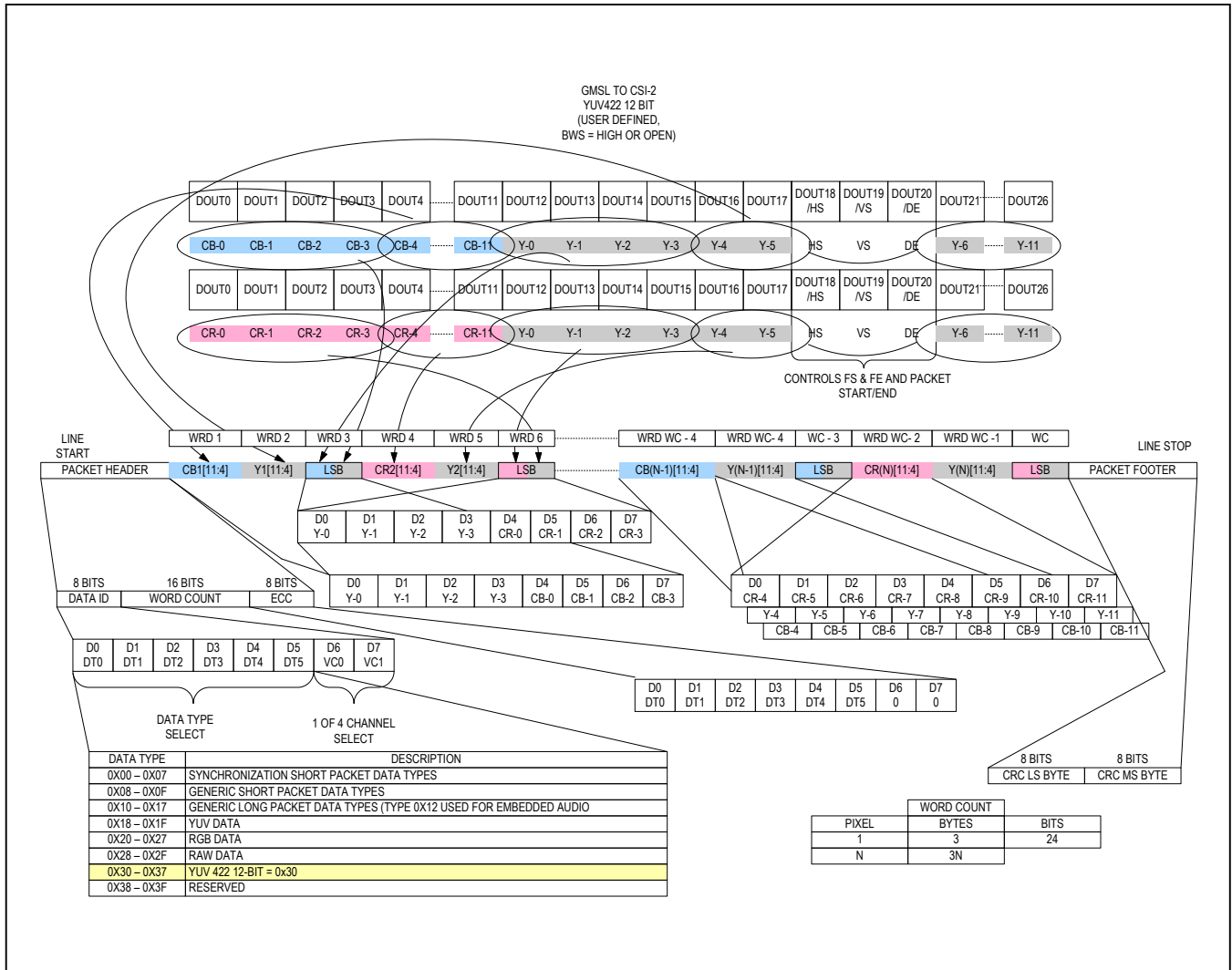

Figure 25. YUV422 12-Bit Output

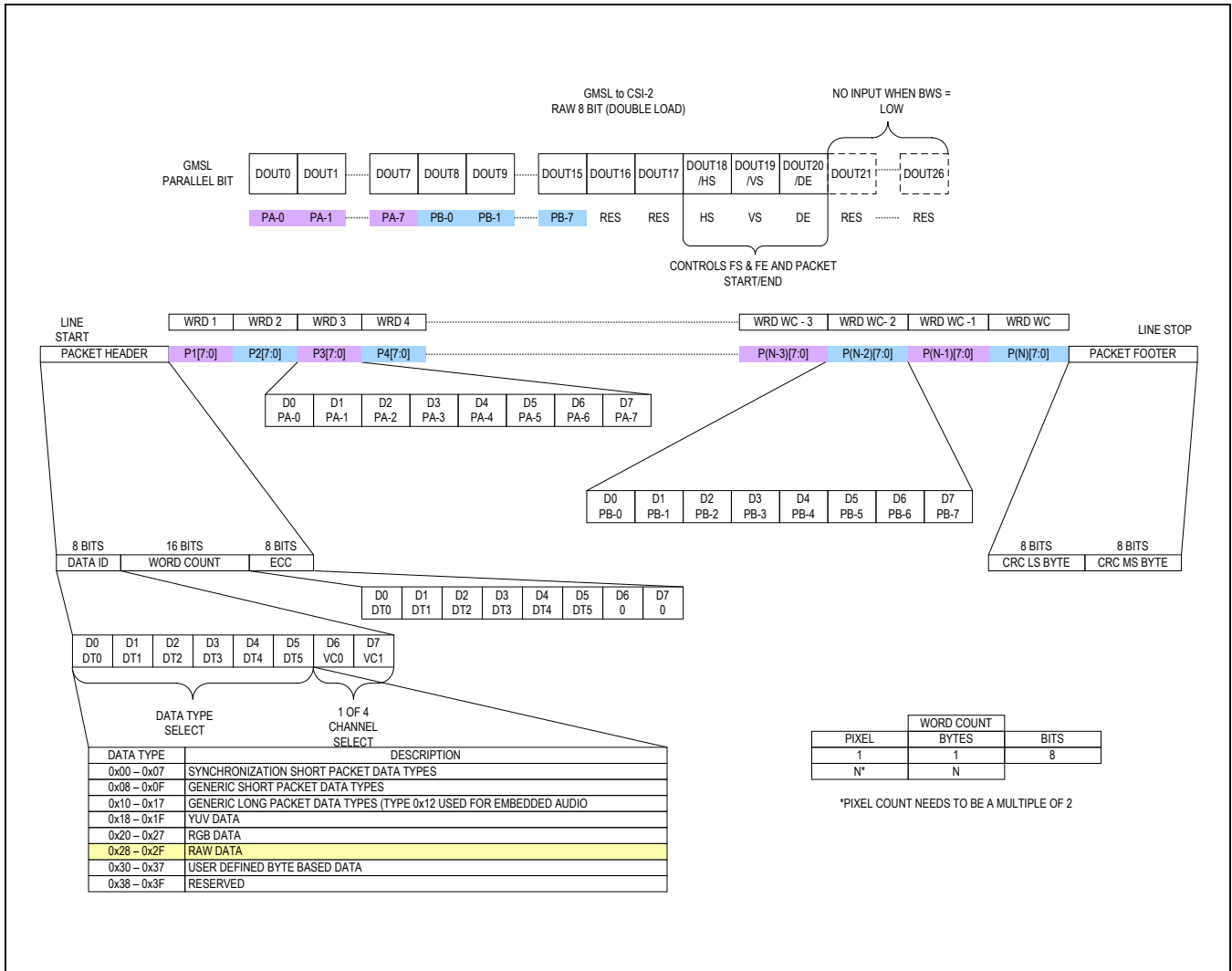

Figure 26. RAW 8-Bit (Double Load) Output

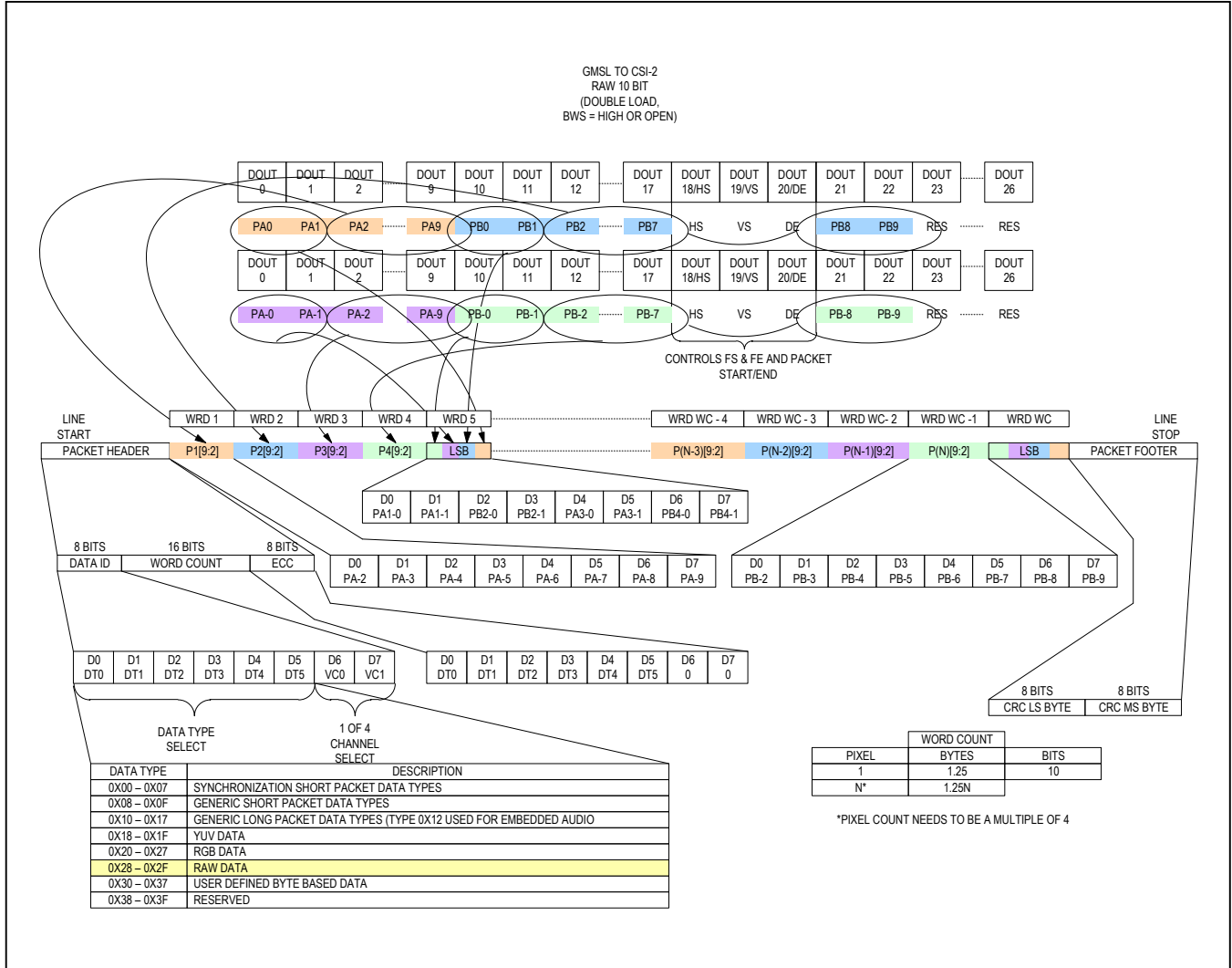

Figure 27. RAW 10-Bit (Double Load) Output

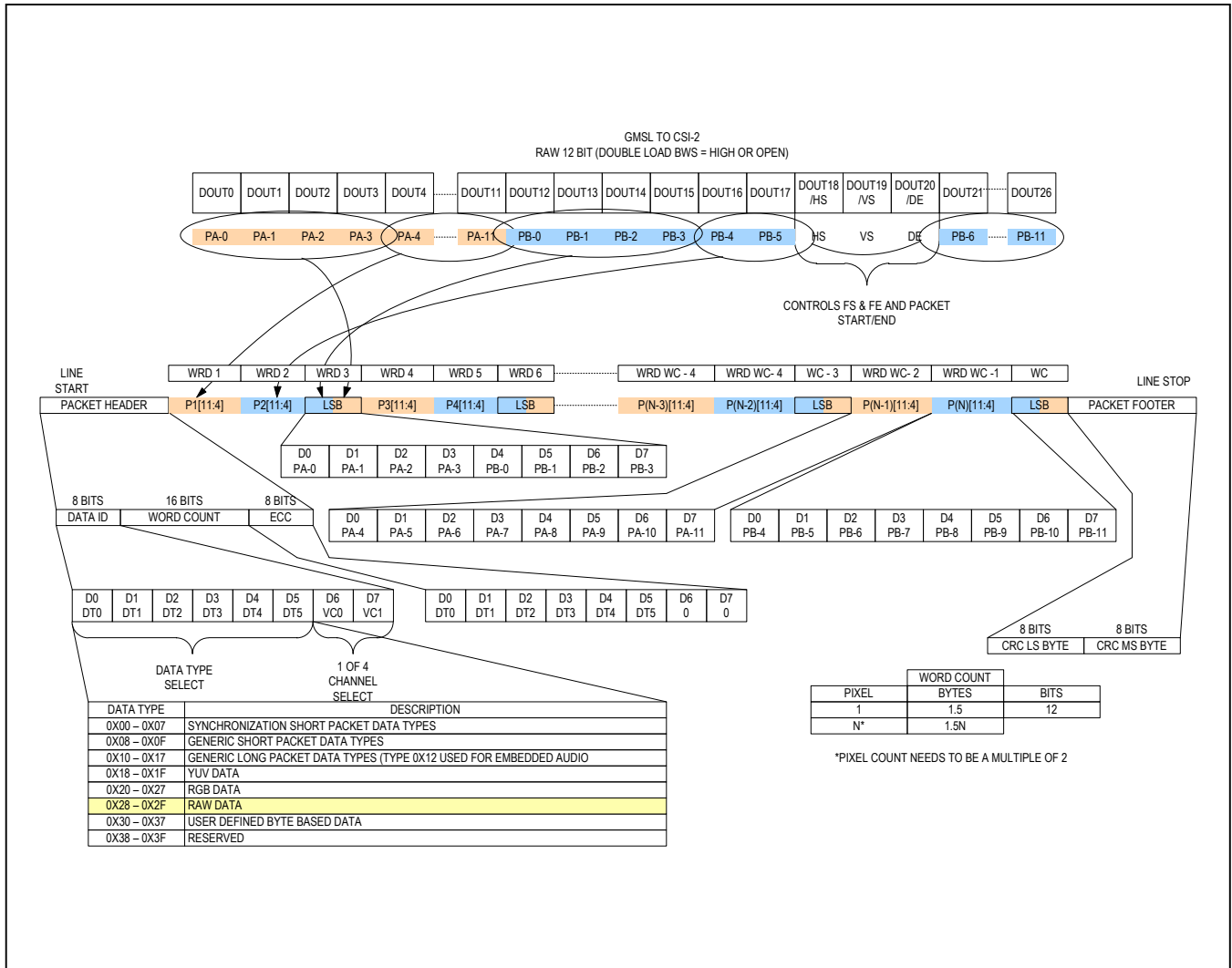

Figure 28. RAW 12-Bit (Double Load) Output

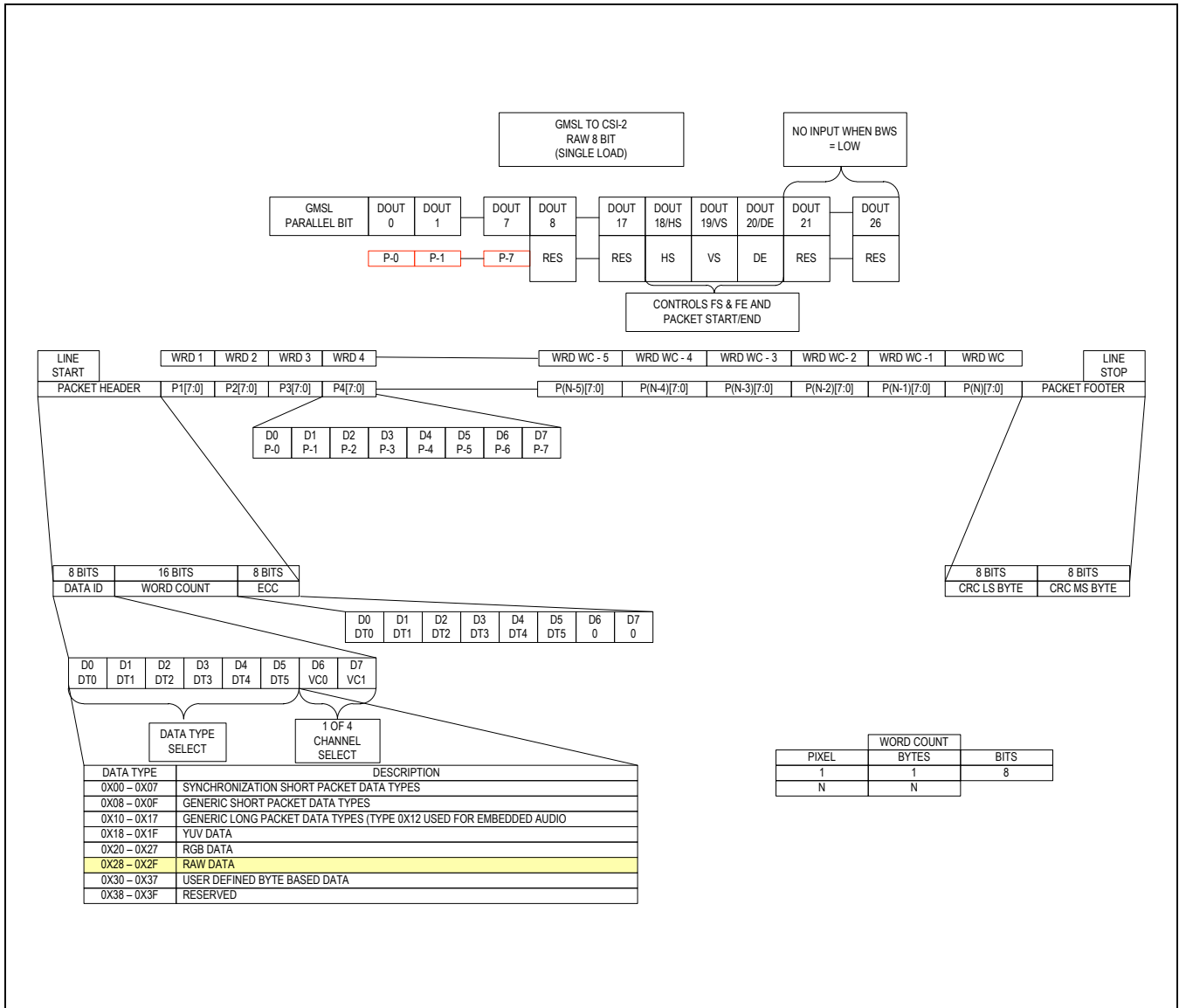

Figure 29. RAW 8-Bit Output

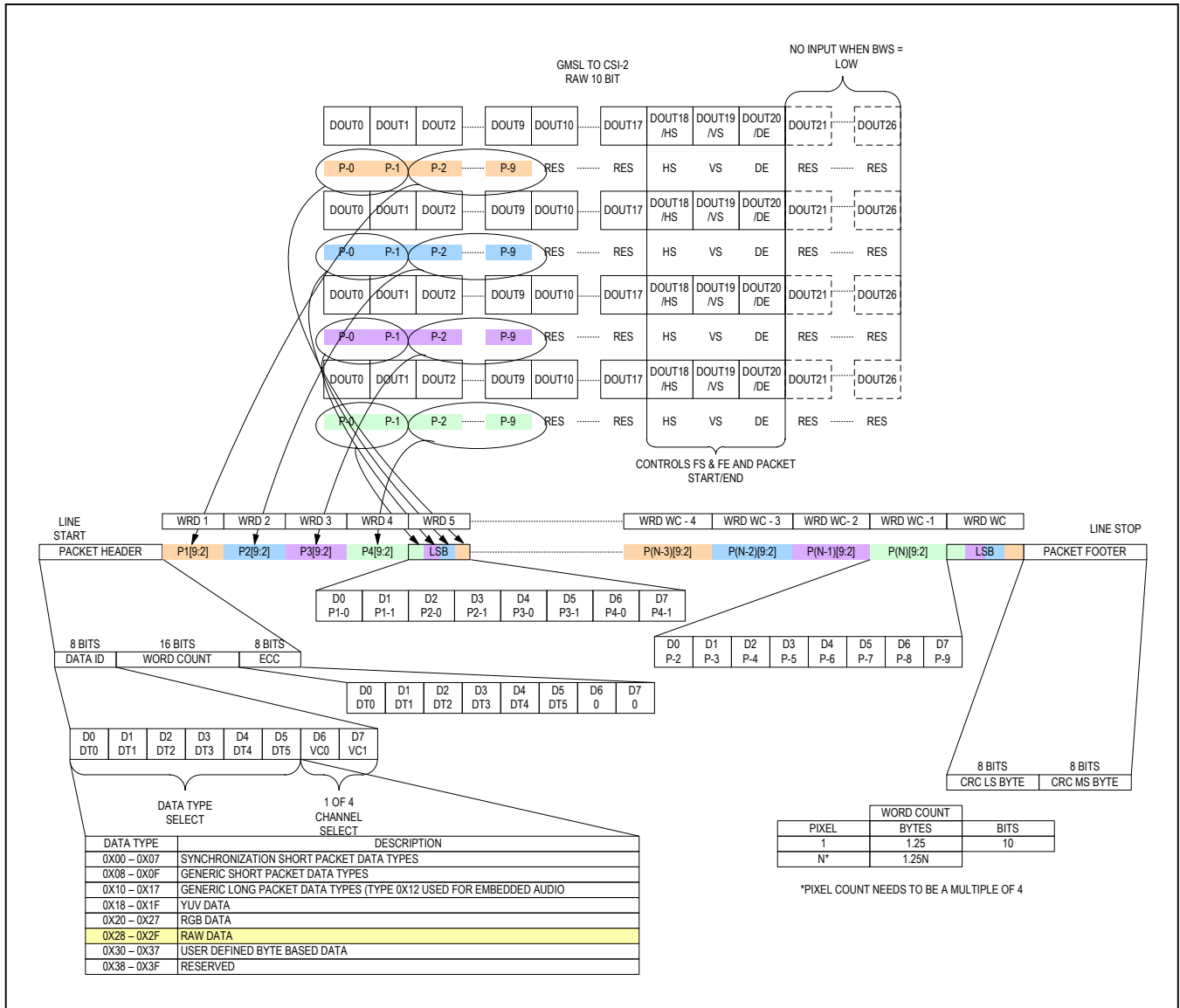

Figure 30. RAW 10-Bit Output

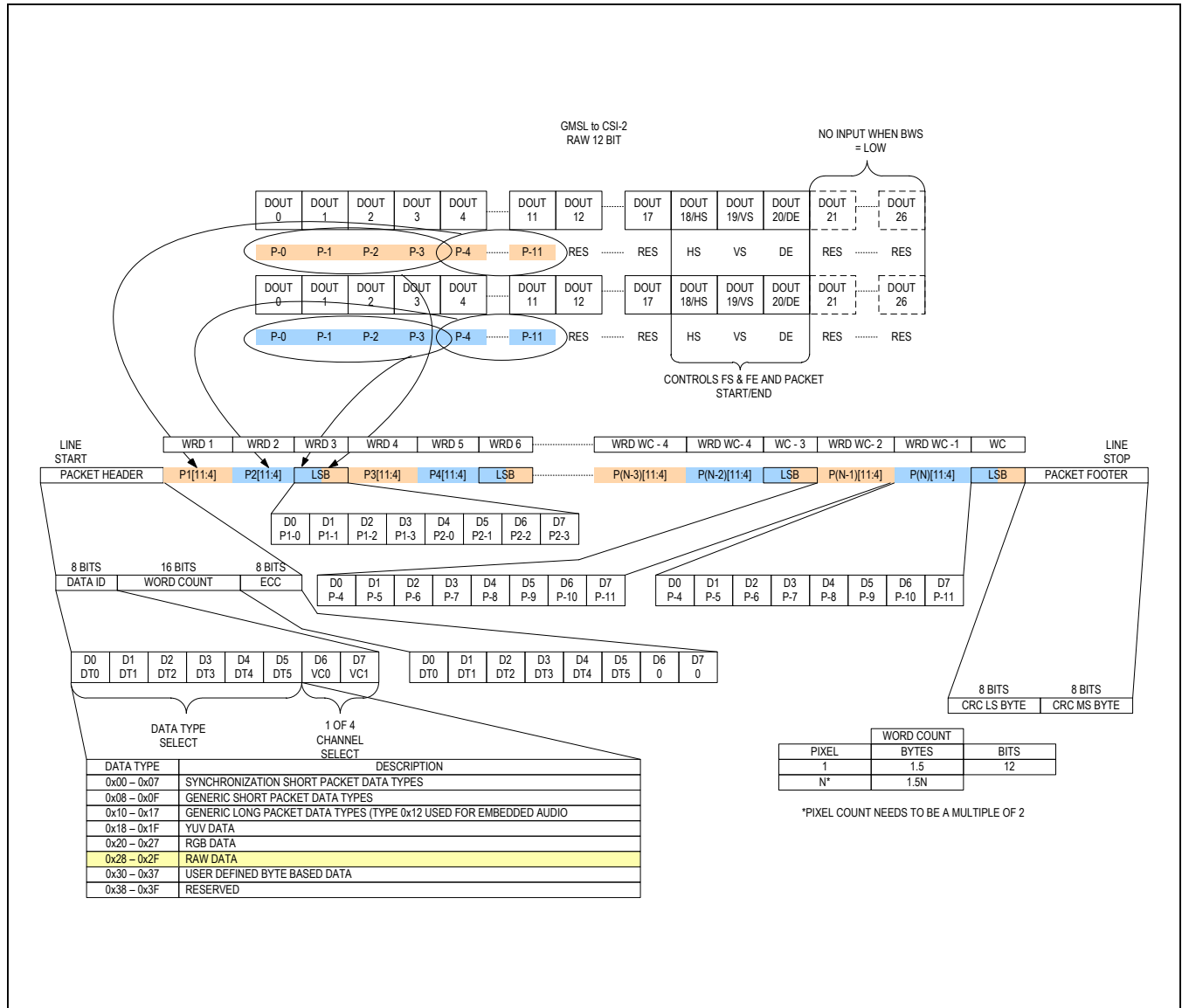

Figure 31. RAW 12-Bit Output

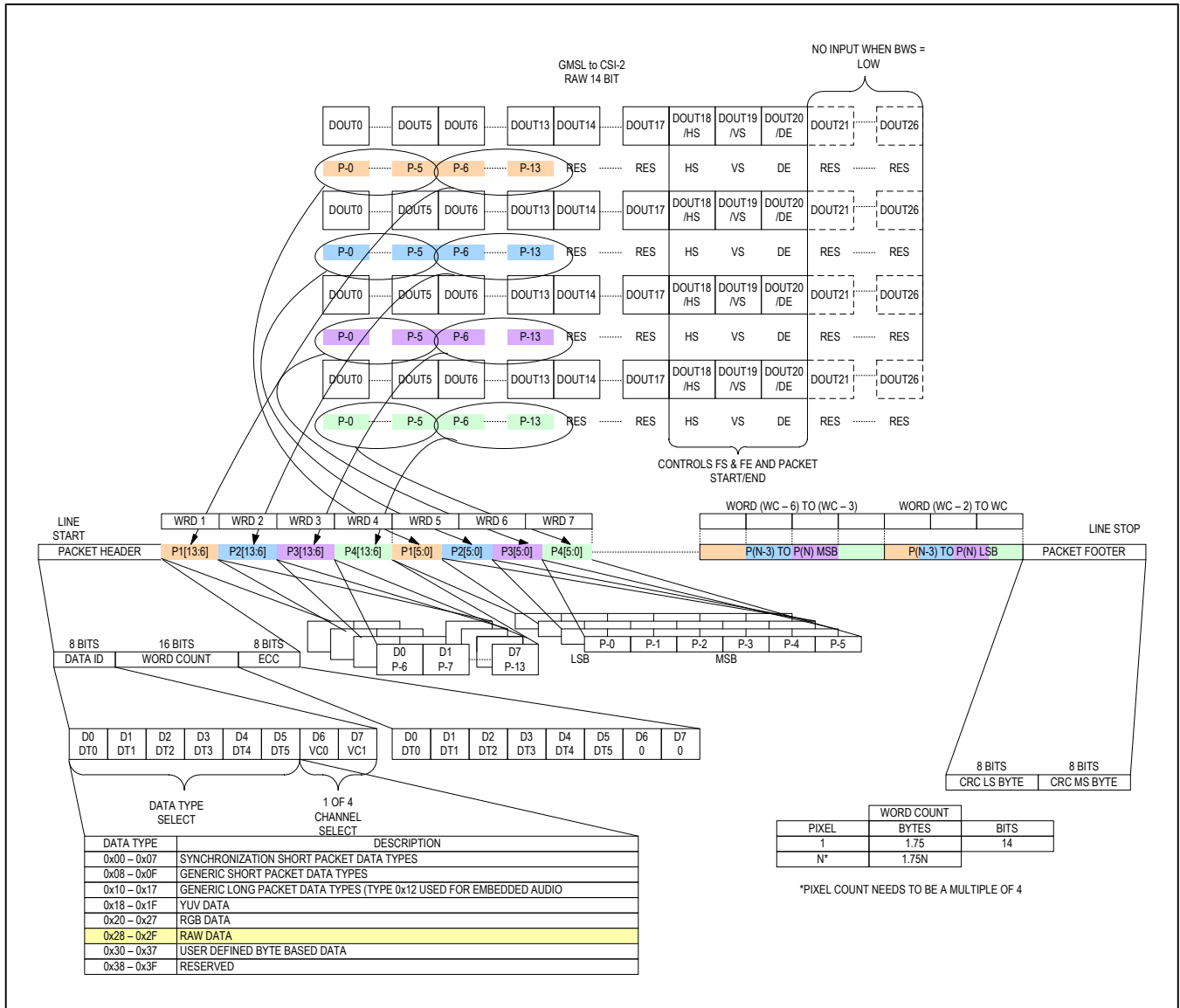

Figure 32. RAW 14-Bit Output

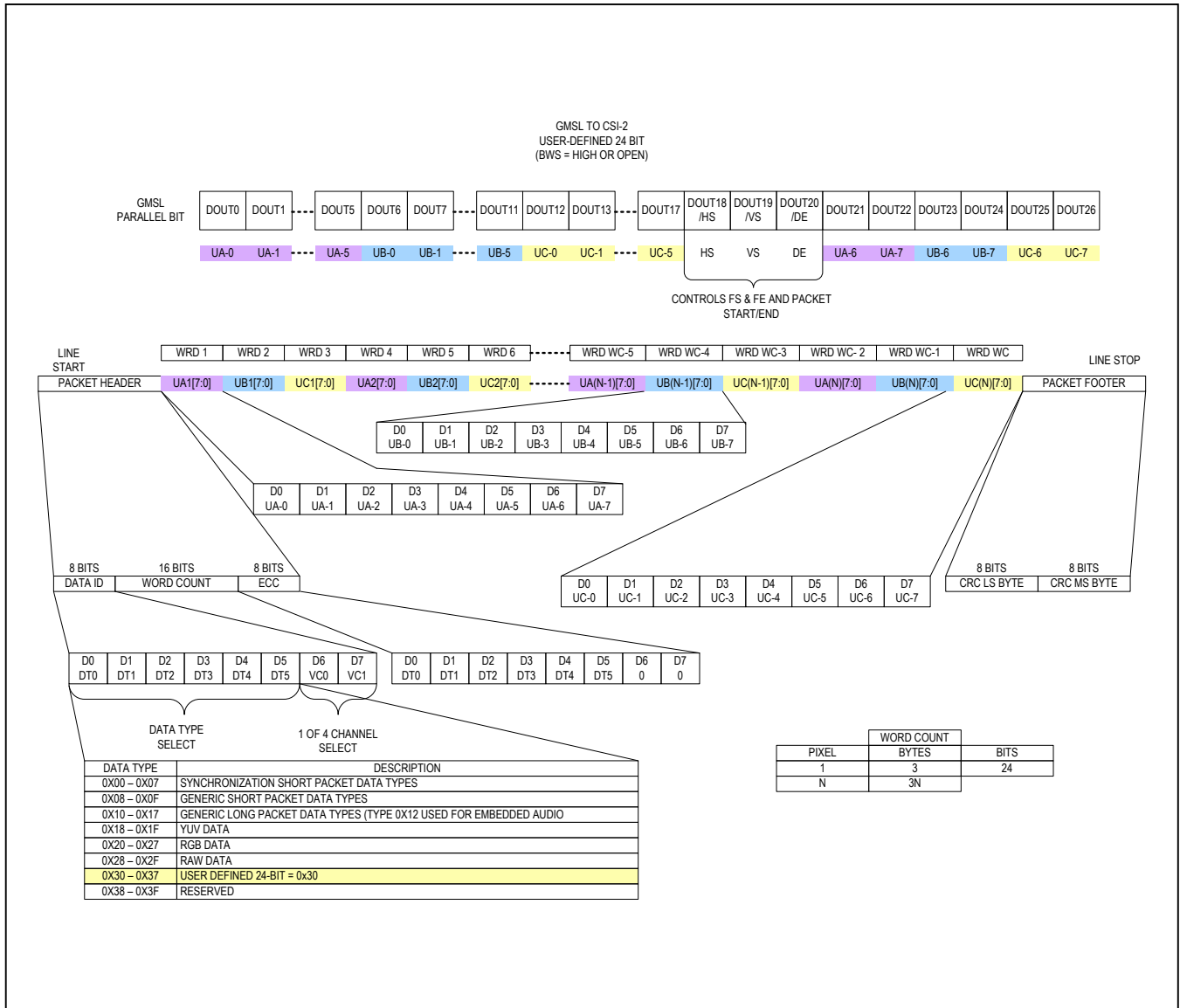

Figure 33. User-Defined 24-Bit Output

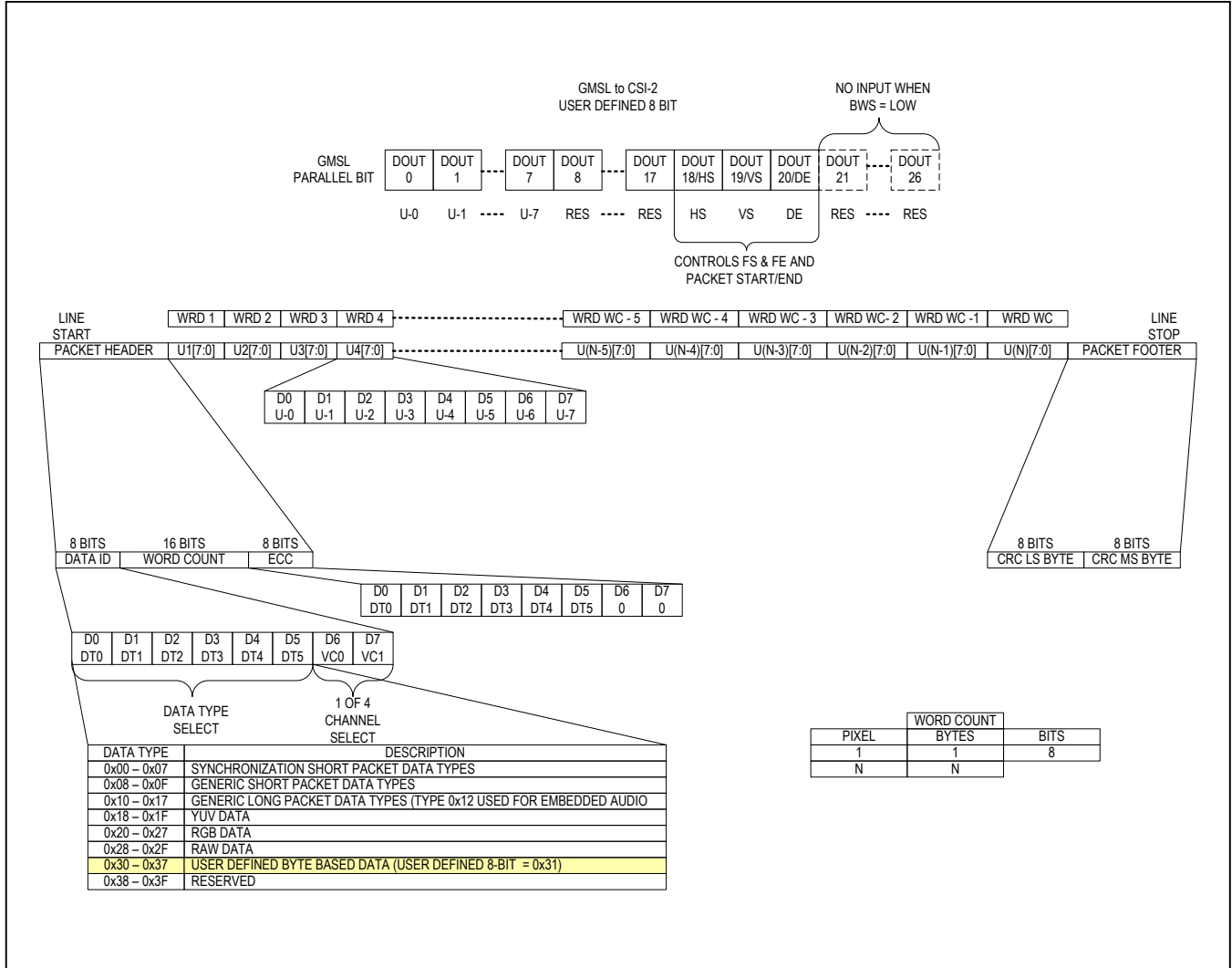

Figure 34. User-Defined 24-Bit Output

Table 2 Video Output Map (RGB and YUV)

GMSL INPUT BITS ¹	RGB			YUV422 ²				
	666	565	888 ^{3*}	8-BIT MUXED	10-BIT MUXED	8-BIT	10-BIT ³	12-BIT ^{3**}
DIN0	R0	R0	R0	Y/Cb/Cr0	Y/Cb/Cr0	Cb/Cr0	Cb/Cr0	Cb/Cr0
DIN1	R1	R1	R1	Y/Cb/Cr1	Y/Cb/Cr1	Cb/Cr1	Cb/Cr1	Cb/Cr1
DIN2	R2	R2	R2	Y/Cb/Cr2	Y/Cb/Cr2	Cb/Cr2	Cb/Cr2	Cb/Cr2
DIN3	R3	R3	R3	Y/Cb/Cr3	Y/Cb/Cr3	Cb/Cr3	Cb/Cr3	Cb/Cr3
DIN4	R4	R4	R4	Y/Cb/Cr4	Y/Cb/Cr4	Cb/Cr4	Cb/Cr4	Cb/Cr4
DIN5	R5	G0	R5	Y/Cb/Cr5	Y/Cb/Cr5	Cb/Cr5	Cb/Cr5	Cb/Cr5
DIN6	G0	G1	G0	Y/Cb/Cr6	Y/Cb/Cr6	Cb/Cr6	Cb/Cr6	Cb/Cr6
DIN7	G1	G2	G1	Y/Cb/Cr7	Y/Cb/Cr7	Cb/Cr7	Cb/Cr7	Cb/Cr7
DIN8	G2	G3	G2	—	Y/Cb/Cr8	Y0	Cb/Cr8	Cb/Cr8
DIN9	G3	G4	G3	—	Y/Cb/Cr9	Y1	Cb/Cr9	Cb/Cr9
DIN10	G4	G5	G4	—	—	Y2	Y0	Cb/Cr10
DIN11	G5	B0	G5	—	—	Y3	Y1	Cb/Cr11
DIN12	B0	B1	B0	—	—	Y4	Y2	Y0
DIN13	B1	B2	B1	—	—	Y5	Y3	Y1
DIN14	B2	B3	B2	—	—	Y6	Y4	Y2
DIN15	B3	B4	B3	—	—	Y7	Y5	Y3
DIN16	B4	—	B4	—	—	—	Y6	Y4
DIN17	B5	—	B5	—	—	—	Y7	Y5
DIN18	HS	HS	HS	HS	HS	HS	HS	HS
DIN19	VS	VS	VS	VS	VS	VS	VS	VS
DIN20	DE	DE	DE	DE	DE	DE	DE	DE
DIN21	—	—	R6	—	—	—	Y8	Y6
DIN22	—	—	R7	—	—	—	Y9	Y7
DIN23	—	—	G6	—	—	—	—	Y8
DIN24	—	—	G7	—	—	—	—	Y9
DIN25	—	—	B6	—	—	—	—	Y10
DIN26	—	—	B7	—	—	—	—	Y11

1. Refer to the GMSL serializer data sheet for details.

2. YUV defaults to muxed input mode (Cb, Y0, Cr, Y1). Set INPUTBW = 1 to use normal input mode (CBY0, CrY1).

3. Data type available when BWS = high or open, only.

*VESA/oLDI bits are mapped to MIPI according to oLDI bit (D4 or register 0x60). Set oLDI bit low when using VESA input or high when using an oLDI input. oLDI defines bits [5:0] as MSB and bits [6:7] as LSB.

**12-bit YUV422 sent using CSI-2 user-defined data type (0x30). The output byte sequence is CB[11:4], Y0[11:4], [CB[3:0], Y0[3:0]], CR[11:4], Y1[11:4], [CR[3:0], and Y1[3:0]].

Auto Pixel-Per-Line Feature

For proper operation, the device requires the information of number of pixels in DE high period. Program the pixel count into registers 0x61 and 0x62. Alternatively, the device can automatically count the number of pixels in DE high period.

Setting the AUTOPPL bit high enables this function. In this mode, the device counts the number of pixels in every DE high period and compares the result with the number of

pixels in the previous DE high period. If both numbers are within ±4 pixels of each other, the deserializer accepts this count as valid count and uses the number to packetize the video data. An AUTOPPL error is issued only when the current pixel count does not match the previous pixel count. An invalid count (±5 or more pixels) stops the packet transmission and issues an AUTOPPL error. This allows the device to tolerate some noise while alerting the user of an error.

Clock Operation

The GMSL deserializer recovers the pixel clock (PCLK) from the serial input. This pixel clock is used to time various functions of the device such as the control signals and MCLK. The pixel, along with the CSI data type, determines the CSI HS clock (CLK+/-). When the clocks are stable, the LOCK pin goes high and the clock transmitter starts the SOT, HS prepare and HS zero sequences and transmits the HS clock in HS differential mode. If the device loses of lock, the clock lane is disabled, and the clock transmitter pulls the line to stop state (LP-11).

Data-Rate Selection and CSI-2 Clock Limitations

Three factors affect the overall useable clock range of the GMSL deserializers: The valid clock range of the GMSL serial input, the MIPI CSI-2 output, and the data bit width. [Table 5](#) lists the valid PCLK range at various CSI-2 output modes. [Table 6](#) shows the valid CSI-2 output-channel bit rate.

Table 3. Video Output Map (RAW and User Defined)

GMSL INPUT BITS ¹	RAW (DOUBLE LOAD ²)			RAW (SINGLE LOAD ²)				USER DEFINED	
	8-BIT	10-BIT ³	12-BIT ³	8-BIT	10-BIT	12-BIT	14-BIT	24-BIT ³	8-BIT
DIN0	PA0	PA0	PA0	P0	P0	P0	P0	UA0	U0
DIN1	PA1	PA1	PA1	P1	P1	P1	P1	UA1	U1
DIN2	PA2	PA2	PA2	P2	P2	P2	P2	UA2	U2
DIN3	PA3	PA3	PA3	P3	P3	P3	P3	UA3	U3
DIN4	PA4	PA4	PA4	P4	P4	P4	P4	UA4	U4
DIN5	PA5	PA5	PA5	P5	P5	P5	P5	UA5	U5
DIN6	PA6	PA6	PA6	P6	P6	P6	P6	UB0	U6
DIN7	PA7	PA7	PA7	P7	P7	P7	P7	UB1	U7
DIN8	PB0	PA8	PA8	—	P8	P8	P8	UB2	—
DIN9	PB1	PA9	PA9	—	P9	P9	P9	UB3	—
DIN10	PB2	PB0	PA10	—	—	P10	P10	UB4	—
DIN11	PB3	PB1	PA11	—	—	P11	P11	UB5	—
DIN12	PB4	PB2	PB0	—	—	—	P12	UC0	—
DIN13	PB5	PB3	PB1	—	—	—	P13	UC1	—
DIN14	PB6	PB4	PB2	—	—	—	—	UC2	—
DIN15	PB7	PB5	PB3	—	—	—	—	UC3	—
DIN16	—	PB6	PB4	—	—	—	—	UC4	—
DIN17	—	PB7	PB5	—	—	—	—	UC5	—
DIN18	HS	HS	HS	HS	HS	HS	HS	HS	HS
DIN19	VS	VS	VS	VS	VS	VS	VS	VS	VS
DIN20	DE	DE	DE	DE	DE	DE	DE	DE	DE
DIN21	—	PB8	PB6	—	—	—	—	UA6	—
DIN22	—	PB9	PB7	—	—	—	—	UA7	—
DIN23	—	—	PB8	—	—	—	—	UB6	—
DIN24	—	—	PB9	—	—	—	—	UB7	—
DIN25	—	—	PB10	—	—	—	—	UC6	—
DIN26	—	—	PB11	—	—	—	—	UC7	—

1. Refer to the GMSL serializer data sheet for details.
2. RAW datatype defaults to single load. Set INPUTBW = 1 to use double input mode (output sequence PA0, PB0, PA1, PB1).
3. Data type available when BWS = high or open, only.

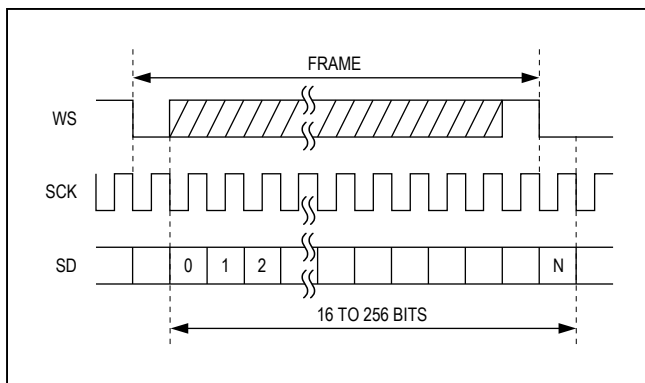

Figure 35. Audio Channel Input Format

GMSL Clock Range

The deserializer uses the DRS pin/bit and the BWS input to set the GMSL pixel clock frequency range (Table 5). Set DRS = 1 for low data rate pixel clock frequency range of 6.25MHz to 16.66MHz. Set DRS = 0 for high data rate pixel clock frequency range of 12.5MHz to 104MHz.

CSI-2 Clock Range

the CSI-2 ports operate from 80Mbps to 1000Mbps per channel. The CSI-2 output bit rate can be calculated from the PCLK rate by the following equation:

$$\text{CSI RATE} = \text{PCLK} \times \text{WIDTH/LANES}$$

where:

PCLK = Input PCLK rate

LANES = Number of CSI-2 lanes used

WIDTH = Bit width of the input data (see Table 5 or Table 6)

High-Bandwidth Mode

The deserializer uses a 27-bit high-bandwidth mode to support 24-bit RGB at 104MHz pixel clock. Set BWS = open in both the serializer and deserializer to use high-bandwidth mode. In high-bandwidth mode, the deserializer decodes HS, VS, DE, and CNTL[3:0] from special packets. Packets are sent by replacing a pixel before the rising edge and after the falling edge of the HS, VS, and DE signals. However, for CNTL[3:0], which is not always continuously sampled, packets always replace a pixel before the transition of the sampled CNTL[3:0]. Keep

HS, VS, and DE low pulse widths at least two pixel clock cycles. By default, CNTL[3:0] are sampled continuously when DE is low. CNTL[3:0] are sampled only on HS/VS transitions when DE is high. If DE triggering of encoded packets is not desired, set the serializer's DISDETRIG = 0 and the CNTLTRIG bits to their desired value (register 0x15) to change the CNTL triggering behavior. Set DETREN = 0 on the deserializer when DE is not periodic.

Audio Channel

The audio channel supports 8kHz to 192kHz audio sampling rates and audio word lengths from 8 bits to 32 bits (2-channel I²S), or 64 to 256 bits (TDM64 to TDM256). The audio bit clock (SCK) does not have to be synchronized with pixel clock. The serializer automatically encodes audio data into a single-bit stream synchronous with pixel clock. The deserializer decodes the audio stream and stores audio words in a FIFO. Audio rate detection uses an internal oscillator to continuously determine the audio data rate and output the audio in I²S format. The audio channel is enabled by default. When the audio channel is disabled, the SD is treated as an auxiliary control signal.

Since the encoded audio data sent through the serial link is synchronized with pixel clock (through ACB), low pixel clock frequencies limit the maximum audio sampling rate. Table 5 lists the maximum audio sampling rate for various pixel clock frequencies. Spread spectrum from the serializer do not affect the I²S/TDM data rate or WS clock frequency.

Audio Channel Input

The audio channel input works with 8-channel TDM and stereo I²S, as well as nonstandard formats. The input format is shown in Figure 35.

The period of the WS can be 8 to 256 SCK periods. The WS frame starts with the falling edge and can be low for 1 to 255 SCK periods. SD is one SCK period, sampled on the rising edge. MSB/LSB order, zero padding, or any other significance assigned to the serial data does not affect operation of the audio channel. The polarity for WS and SCK edges is programmable.

Figure 36, Figure 37, Figure 38, and Figure 39 are examples of acceptable input formats.

Table 4. Control Output Map

CONTROL OUTPUTS	MODE		
	24-BIT MODE (BWS = LOW)	HIGH-BANDWIDTH MODE (BWS = MID)	32-BIT MODE (BWS = HIGH)
CNTL0	Not used	Used*	Not used
CNTL1	Not used	Used*	Used**
CNTL2	Not used	Used*	Used**
CNTL3	Not used	Used*	Not used

Note: See the [High-Bandwidth Mode](#) section for details on timing requirements.

*Outputs used only when the respective color lookup tables are enabled.

**Not encrypted when HDCP is enabled (MAX9290 only).

Table 5. GMSL Data-Rate Selection Table

DRS BIT SETTING	BWS PIN SETTING	PIXEL CLOCK RANGE (MHz)
0 (high data rate)	Low (24-bit mode)	16.66 to 104
	Mid (high-bandwidth mode)	36.66 to 104
	High (32-bit mode)	12.5 to 78
1 (low data rate)	Low	8.33 to 16.66
	Mid	18.33 to 36.66
	High	6.25 to 12.5

Table 6. Input Pixel Clock Range (MHz)

GMSL BIT WIDTH	CSI-2 OUTPUT MODES	NUMBER OF CSI-2 LANES	DRS LOW			DRS HIGH		
			BWS LOW	BWS OPEN	BWS HIGH	BWS LOW	BWS OPEN	BWS HIGH
8	RAW8 (Single Load) YUV422 8b Muxed	1	16.67 to 104	36.67 to 104	12.5 to 78	10 to 16.67	18.33 to 36.67	10 to 12.5
		2	20 to 104	36.67 to 104	20 to 78	Do not use	20 to 36.67	Do not use
		3	30 to 104	36.67 to 104	30 to 78	Do not use	30 to 36.67	Do not use
		4	40 to 104	40 to 104	40 to 78	Do not use	Do not use	Do not use

Table 6. Input Pixel Clock Range (MHz) (continued)

GMSL BIT WIDTH	CSI-2 OUTPUT MODES	NUMBER OF CSI-2 LANES	DRS LOW			DRS HIGH		
			BWS LOW	BWS OPEN	BWS HIGH	BWS LOW	BWS OPEN	BWS HIGH
10	RAW10 (Single Load) YUV422 10b Muxed	1	16.67 to 100	36.67 to 100	12.5 to 78	8.333 to 16.67	18.33 to 36.67	8 to 12.5
		2	16.67 to 104	36.67 to 104	16 to 78	16 to 16.67	18.33 to 36.67	Do not use
		3	24 to 104	36.67 to 104	24 to 78	Do not use	24 to 36.67	Do not use
		4	32 to 104	36.67 to 104	32 to 78	Do not use	32 to 36.67	Do not use
12	RAW12 (Single Load)	1	16.67 to 83.33	36.67 to 83.3	12.5 to 78	8.333 to 16.67	18.33 to 36.67	6.667 to 12.5
		2	16.67 to 104	36.67 to 104	13.33 to 78	13.33 to 16.67	18.33 to 36.67	Do Not Use
		3	20 to 104	36.67 to 104	20 to 78	Do not use	20 to 36.67	Do not use
		4	26.67 to 104	36.67 to 104	26.67 to 78	Do not use	26.67 to 36.67	Do not use
14	RAW14 (Single Load)	1	16.67 to 71.43	36.67 to 71.43	12.5 to 71.43	8.333 to 16.67	18.33 to 36.67	6.25 to 12.5
		2	16.67 to 104	36.67 to 104	12.5 to 78	11.43 to 16.67	18.33 to 36.67	11.43 to 12.5
		3	17.14 to 104	36.67 to 104	17.14 to 78	Do not use	18.33 to 36.67	Do not use
		4	22.86 to 104	36.67 to 104	22.86 to 78	Do not use	22.86 to 36.67	Do not use
16	RAW8 (Double Load) YUV442 8b RGB565	1	16.67 to 62.5	36.67 to 62.5	12.5 to 62.5	8.333 to 16.67	18.33 to 36.67	6.25 to 12.5
		2	16.67 to 104	36.67 to 104	12.5 to 78	10 to 16.67	18.33 to 36.67	10 to 12.5
		3	16.67 to 104	36.67 to 104	15 to 78	15 to 16.67	18.33 to 36.67	Do Not Use
		4	20 to 104	36.67 to 104	20 to 78	Do not use	20 to 36.67	Do not use

Table 6. Input Pixel Clock Range (MHz) (continued)

GMSL BIT WIDTH	CSI-2 OUTPUT MODES	NUMBER OF CSI-2 LANES	DRS LOW			DRS HIGH		
			BWS LOW	BWS OPEN	BWS HIGH	BWS LOW	BWS OPEN	BWS HIGH
18	RGB666	1	16.67 to 55.56	36.67 to 55.56	12.5 to 55.56	8.333 to 16.67	18.33 to 36.67	6.25 to 12.5
		2	16.67 to 104	36.67 to 104	12.5 to 78	8.889 to 16.67	18.33 to 36.67	8.889 to 12.5
		3	16.67 to 104	36.67 to 104	13.33 to 78	13.33 to 16.67	18.33 to 36.67	Do not use
		4	16.67 to 104	36.67 to 104	17.78 to 78	Do not use	18.33 to 36.67	Do not use
20	RAW10 (Double Load) YUV442 10b	1	Do not use	36.67 to 50	12.5 to 50	Do not use	18.33 to 36.67	6.25 to 12.5
		2	Do not use	36.67 to 100	12.5 to 78	Do not use	18.33 to 36.67	8 to 12.5
		3	Do not use	36.67 to 104	12.5 to 78	Do not use	18.33 to 36.67	12 to 12.5
		4	Do not use	36.67 to 104	16 to 78	Do Not Use	18.33 to 36.67	Do Not Use
24	RAW12 (Double Load) YUB442 12b RGB888 User-defined 8b User-defined 24b	1	Do not use	36.67 to 41.67	12.5 to 41.67	Do not use	18.33 to 36.67	6.25 to 12.5
		2	Do not use	36.67 to 83.33	12.5 to 78	Do not use	18.33 to 36.67	6.667 to 12.5
		3	Do not use	36.67 to 104	12.5 to 78	Do not use	18.33 to 36.67	10 to 12.5
		4	Do not use	36.67 to 104	13,33 to 78	Do not use	18.33 to 36.67	Do not use

Table 7. Output CSI-2 Data Rate Range (Mbps)

GMSL BIT WIDTH	CSI-2 OUTPUT MODES	NUMBER OF CSI-2 LANES	DRS LOW			DRS HIGH		
			BWS LOW	BWS OPEN	BWS HIGH	BWS LOW	BWS OPEN	BWS HIGH
8	RAW8 (Single Load) YUV422 8b Muxed	1	133.3 to 832	293.3 to 832	100 to 624	80 to 133.3	146.7 to 293.3	80 to 100
		2	80 to 416	146.7 to 832	80 to 312	Do Not Use	80 to 146.7	Do Not Use
		3	80 to 277.3	97.78 to 277.3	80 to 208	Do Not Use	80 to 97.76	Do Not Use
		4	80 to 208	80 to 208	80 to 156	Do Not Use	Do Not Use	Do Not Use
10	RAW10 (Single Load) YUV422 10b Muxed	1	166.7 to 1000	366.7 to 1000	125 to 780	83.33 to 166.7	183.3 to 366.7	80 to 125
		2	83.33 to 520	183.3 to 520	80 to 390	80 to 83.33	91.67 to 183.3	Do Not Use
		3	80 to 346.7	122.22 to 346.7	80 to 260	Do Not Use	80 to 122.2	Do Not Use
		4	80 to 260	91.67 to 260	80 to 195	Do Not Use	80 to 91.67	Do Not Use
12	RAW12 (Single Load)	1	200 to 1000	440 to 1000	150 to 936	100 to 200	220 to 440	80 to 150
		2	100 to 624	220 to 624	80 to 468	80 to 100	110 to 220	Do Not Use
		3	80 to 416	147 to 416	80 to 312	Do Not Use	80 to 147	Do Not Use
		4	80 to 312	147 to 312	80 to 234	Do Not Use	80 to 110	Do Not Use
14	RAW14 (Single Load)	1	233.3 to 1000	513.3 to 1000	175 to 1000	116.7 to 233.3	256.7 to 513.3	87.5 to 175
		2	116.7 to 728	256.7 to 1728	87.5 to 546	80 to 116.7	128.3 to 256.7	80 to 87.5
		3	80 to 485.3	171.1 to 485.3	80 to 364	Do Not Use	80 to 171.1	Do Not Use
		4	80 to 364	80 to 364	80 to 273	Do Not Use	80 to 128.3	Do Not Use

Table 7. Output CSI-2 Data Rate Range (Mbps) (continued)

GMSL BIT WIDTH	CSI-2 OUTPUT MODES	NUMBER OF CSI-2 LANES	DRS LOW			DRS HIGH		
			BWS LOW	BWS OPEN	BWS HIGH	BWS LOW	BWS OPEN	BWS HIGH
16	RAW8 (Double Load) YUV442 8b RGB565	1	256.7 to 1000	586.7 to 1000	200 to 1000	133.3 to 266.7	293.3 to 586.7	100 to 200
		2	133.3 to 832	293.3 to 832	100 to 624	80 to 133.3	146.7 to 293.3	80 to 100
		3	88.89 to 554.7	195.6 to 554.7	80 to 416	80 to 88.89	97.78 to 195.6	Do Not Use
		4	80 to 416	146.7 to 832	80 to 312	Do Not Use	80 to 146.7	Do Not Use
18	RGB666	1	300 to 1000	660 to 1000	225 to 1000	150 to 300	330 to 660	112.5 to 225
		2	150 to 936	330 to 936	112.5 to 702	80 to 150	165 to 330	80 to 112.5
		3	100 to 624	110 to 624	80 to 468	80 to 100	110 to 220	Do Not Use
		4	80 to 468	165 to 468	80 to 351	Do Not Use	82.5 to 165	Do Not Use
20	RAW10 (Double load) YUV442 10b	1	Do Not Use	733.3 to 1000	250 to 1000	Do Not Use	366.6 to 733.3	120 to 250
		2	Do Not Use	366.7 to 1000	125 to 780	Do Not Use	183.3 to 366.7	80 to 125
		3	Do Not Use	244.4 to 93.3	83.33 to 520	Do Not Use	122.2 to 244.4	80 to 83.33
		4	Do Not Use	183.3 to 520	80 to 390	Do Not Use	91.67 to 183.3	Do Not Use
24	RAW12 (Double load) YUB442 12b RGB888 User Defined 8b User Defined 24b	1	Do Not Use	880 to 1000	300 to 1000	Do Not Use	440 to 880	150 to 300
		2	Do Not Use	440 to 1000	150 to 936	Do Not Use	220 to 440	80 to 150
		3	Do Not Use	293.3 to 832	100 to 624	Do Not Use	146.7 to 293.3	80 to 100
		4	Do Not Use	220 to 624	80 to 468	Do Not Use	110 to 220	Do Not Use

Table 8. Maximum Audio WS Frequency (kHz) for Various Pixel Clock Frequencies

CHANNELS	BITS PER CHANNEL	PIXEL CLOCK FREQUENCY (DRS = 0*) (MHz)										
		12.5	15.0	16.6	20.0	25.0	30.0	35.0	40.0	45.0	50.0	100
2	8	+	+	+	+	+	+	+	+	+	+	+
	16	+	+	+	+	+	+	+	+	+	+	+
	18	185.5	+	+	+	+	+	+	+	+	+	+
	20	174.6	+	+	+	+	+	+	+	+	+	+
	24	152.2	182.7	+	+	+	+	+	+	+	+	+
	32	123.7	148.4	164.3	+	+	+	+	+	+	+	+
4	8	+	+	+	+	+	+	+	+	+	+	+
	16	123.7	148.4	164.3	+	+	+	+	+	+	+	+
	18	112.0	134.4	148.8	179.2	+	+	+	+	+	+	+
	20	104.2	125.0	138.3	166.7	+	+	+	+	+	+	+
	24	88.6	106.3	117.7	141.8	177.2	+	+	+	+	+	+
	32	69.9	83.8	92.8	111.8	139.7	167.6	+	+	+	+	+
6	8	152.2	182.7	+	+	+	+	+	+	+	+	+
	16	88.6	106.3	117.7	141.8	177.2	+	+	+	+	+	+
	18	80.2	93.3	106.6	128.4	160.5	+	+	+	+	+	+
	20	73.3	88.0	97.3	117.3	146.6	175.9	+	+	+	+	+
	24	62.5	75.0	83.0	100	125	150	175	+	+	+	+
	32	48.3	57.9	64.1	77.2	96.5	115.9	135.2	154.5	173.8	+	+
8	8	123.7	148.4	164.3	+	+	+	+	+	+	+	+
	16	69.9	83.8	92.8	111.8	139.7	167.6	+	+	+	+	+
	18	62.5	75.0	83.0	100.0	125.0	150.0	175.0	+	+	+	+
	20	57.1	68.5	75.8	91.3	114.2	137.0	159.9	182.7	+	+	+
	24	48.3	57.9	64.1	77.2	96.5	115.9	135.2	154.5	173.8	+	+
	32	37.1	44.5	49.3	59.4	74.2	89.1	103.9	118.8	133.6	148.4	+

COLOR CODING
< 48kHz
48kHz to 96kHz
96kHz to 192kHz
> 192kHz

+Max WS rate is greater than 192kHz.

*DRS = 0 pixel clock frequency is equal to 2x the DRS = 1 pixel clock frequency.

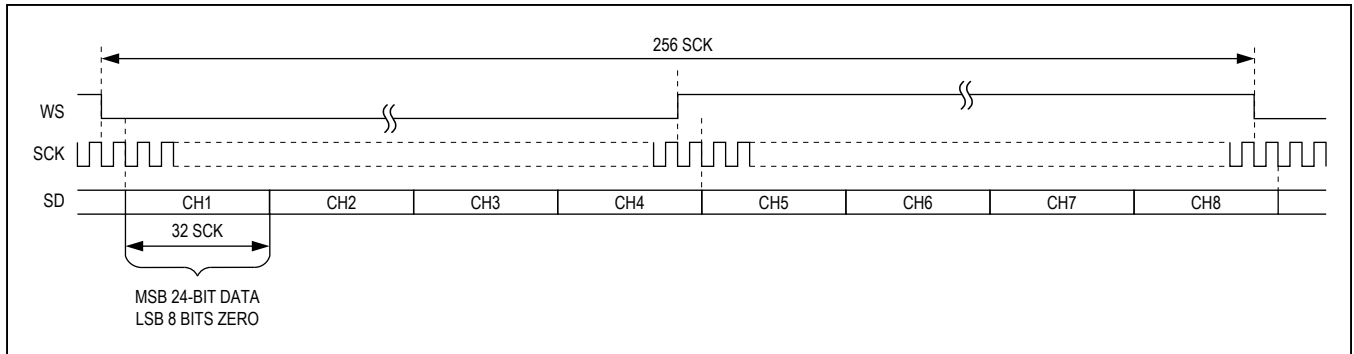

Figure 36. 8-Channel TDM (24-Bit Samples, Padded with Zeros)

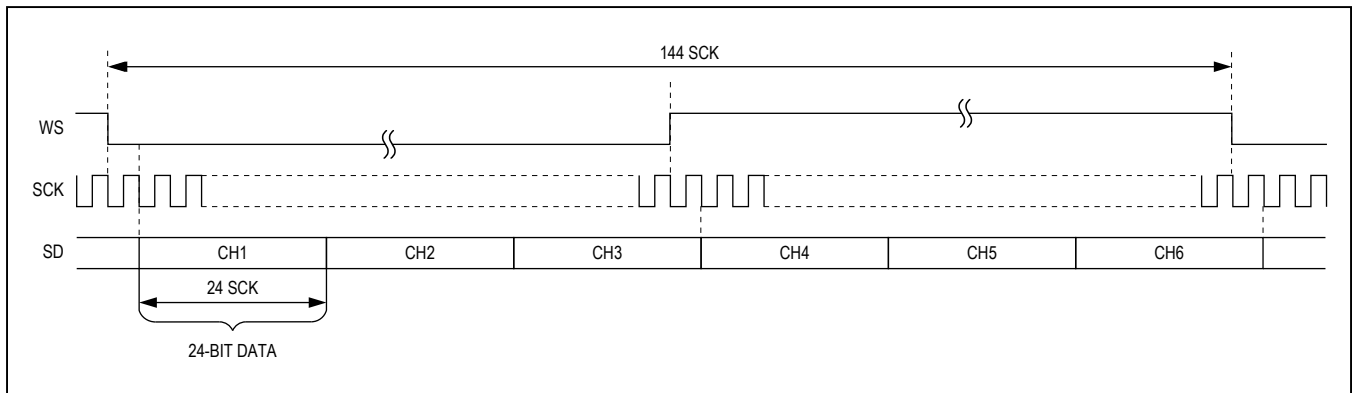

Figure 37. 6-Channel TDM (24-Bit Samples, No Padding)

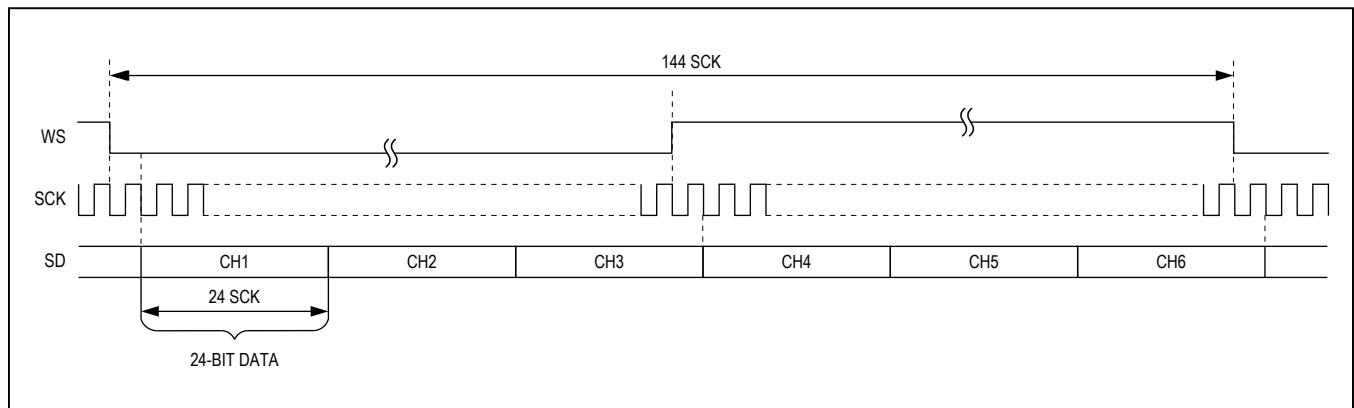

Figure 38. Stereo I²S (24-Bit Samples, Padded with Zeros)

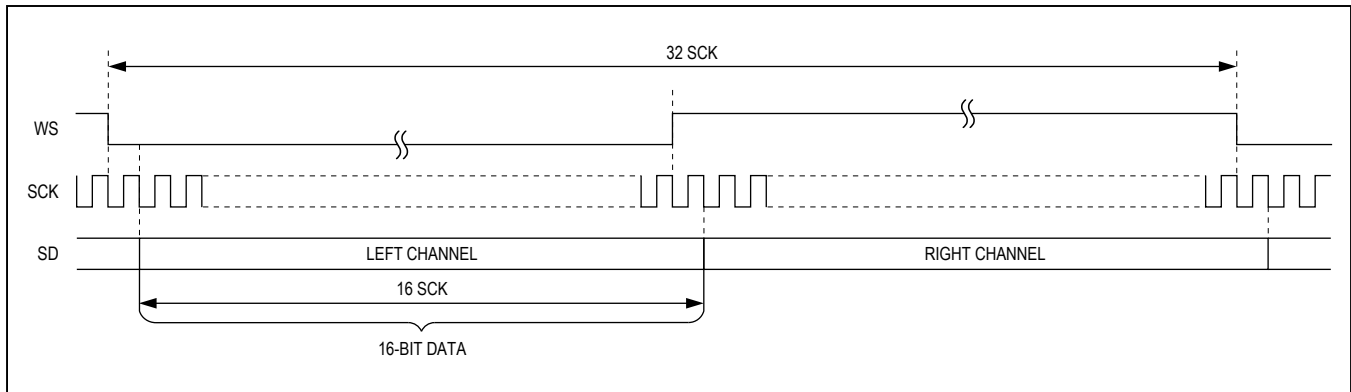

Figure 39. Stereo I²S (16-Bit Samples, No Padding)

Audio Channel Output

WS, SCK, and SD are output with the same timing relationship they had at the audio input, except that WS is always 50% duty cycle (regardless of the duty cycle of WS at the input).

The output format is shown in [Figure 40](#).

WS and SCK can be driven by the audio source (clock master) or the audio sink (clock slave). Buffer underflow and overflow flags are available to the sink as clock slave through I²C for clock frequency adjustment. Data are sampled on the rising edge. WS and SCK polarity is programmable.

Additional MCLK Output for Audio Applications

Some audio DACs, such as the MAX9850, do not require a synchronous main clock (MCLK), while other DACs require a separate MCLK for operation. For audio applications that cannot use WS directly, the deserializer provides a divided MCLK output at either CNTL2 or CNTL0 (determined by MCLKPIN bit setting) at the expense of one less control line. By default, MCLK is turned off. Set MCLKDIV (deserializer register 0x12, D[6:0]) to a nonzero value to enable the MCLK output. Set MCLKDIV to 0x00 to disable MCLK and set CNTL2 or CNTL0 as a control output.

The output MCLK frequency is:

$$f_{\text{MCLK}} = \frac{f_{\text{SRC}}}{\text{MCLKDIV}}$$

where:

f_{SRC} is the MCLK source frequency (see [Table 9](#))

MCLKDIV is the divider ratio from 1 to 127

Choose MCLKDIV values so that f_{MCLK} is not greater than 60MHz. MCLK frequencies derived from pixel clock (MCLKSRC = 0) are not affected by spread-spectrum settings in the deserializer. Enabling spread spectrum

in the serializer, however, introduces spread spectrum into MCLK. Spread-spectrum settings of either device do not affect MCLK frequencies derived from the internal oscillator. The internal oscillator frequency ranges from 100MHz to 150MHz over all process corners and operating conditions. Alternatively, set MCLKWS = 1 (0x15 D1) to output WS from MCLK.

Audio Output Timing Sources

The deserializer has multiple options for audio data output timing. By default, the deserializer provides the output timing based on the incoming data rate (through a FIFO) and an internal oscillator.

To use a system-sourced clock, set the AUDIOMODE bit to 1 (D5 of register 0x02) to set WS and SCK as inputs on the deserializer side. The deserializer uses a FIFO to smooth out the differences in input and output audio timing. Registers 0x78 and 0x79 store the FIFO overflow/underflow information for use with external WS/SCK timing. The FIFO drops data packets during FIFO overflow. By default, the FIFO repeats the last audio packet during FIFO underflow when no audio data is available. Set the AUDUFBEH bit (D2 of register 0x01D) to 1 to output all zeroes during underflow.

Reverse Control Channel

The serializer uses the reverse control channel to receive I²C/UART, MS, and GPO signals from the deserializer in the opposite direction of the video stream. The reverse control channel and forward video data coexist on the same serial cable forming a bidirectional link. The reverse control channel operates independently from the forward control channel. The reverse control channel is available 2ms after power-up. The serializer temporarily disables the reverse control channel for 500 μ s after starting/stopping the forward serial link.

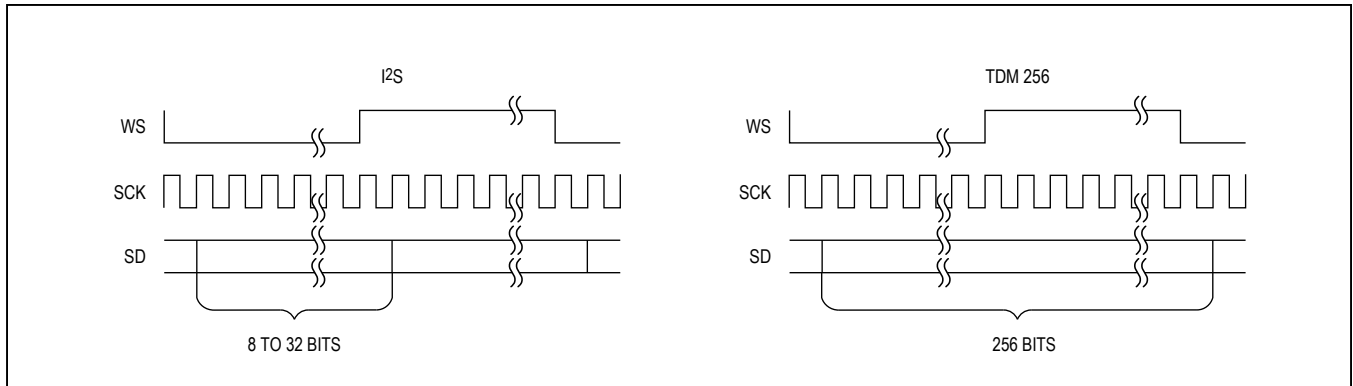

Figure 40. Audio Channel Output Format

Table 9. f_{SRC} Settings

MCLKWS SETTING (REGISTER 0x15, D1)	MCLKSRC SETTING (REGISTER 0x12, D7)	DATA RATE SETTING	BIT-WIDTH SETTING	MCLK SOURCE FREQUENCY (f_{SRC})
0	0	High speed (DRS = 0)	24-bit or high-bandwidth mode	$3 \times f_{PIXEL}$
			32-bit mode	$4 \times f_{PIXEL}$
	Low speed (DRS = 1)	24-bit or high-bandwidth mode	$6 \times f_{PIXEL}$	
		32-bit mode	$8 \times f_{PIXEL}$	
	1	—	—	Internal oscillator (120MHz typ)
1	—	—	—	WS*

*MCLK is not divided when using WS as the MCLK source. MCLK divider must still be set to a nonzero number for MCLK to be enabled.

Control Channel and Register Programming

The control channel is available for the μC to send and receive control data over the serial link simultaneously with the high-speed data. The μC controls the link from either the serializer or the deserializer side to support video-display or image-sensing applications. The control channel between the μC and serializer or deserializer runs in base mode or bypass mode according to the mode-selection input (MS) of the device connected to the μC . Base mode is a half-duplex control channel and bypass mode is a full-duplex control channel. The total maximum forward or reverse control-channel delay is $2\mu s$ (UART) or 2-bit times (I²C) from the input of one device to the output of the other. I²C delay is measured from a START condition to a STOP condition.

UART Interface

In base mode, the μC is the host and can access the registers of both the serializer and deserializer from either side of the link using the GMSL UART protocol. The μC can also program the peripherals on the remote side by

sending the UART packets to the serializer or deserializer, with the UART packets converted to I²C by the device on the remote side of the link. The μC communicates with a UART peripheral in base mode (through INTTYPE register settings), using the half-duplex default GMSL UART protocol of the serializer/deserializer. The device addresses of the serializer and deserializer in base mode are programmable.

When the peripheral interface is I²C, the serializer/deserializer convert UART packets to I²C that have device addresses different from those of the serializer or deserializer. The converted I²C bit rate is the same as the original UART bit rate.

The deserializer uses differential line coding to send signals over the reverse channel to the serializer. The bit rate of the control channel is 9.6kbps to 1Mbps in both directions. The serializer and deserializer automatically detect the control-channel bit rate in base mode. Packet bit-rate changes can be made in steps of up to 3.5 times higher or lower than the previous bit rate. See the [Changing the Clock Frequency](#) section for more information.

Figure 41 shows the UART protocol for writing and reading in base mode between the μ C and the serializer/deserializer.

Figure 42 shows the UART data format. Even parity is used. Figure 43 and Figure 44 detail the formats of the SYNC byte (0x79) and the ACK byte (0xC3). The μ C and the connected slave chip generate the SYNC byte and ACK byte, respectively. Events such as device wake-up and GPI generate transitions on the control channel that can be ignored by the μ C. Data written to the deserializer registers do not take effect until after the ACK byte is sent. This allows the μ C to verify that write commands are received without error, even if the result of the write

command directly affects the serial link. The slave uses the SYNC byte to synchronize with the host UART's data rate. If the GPI or MS inputs of the deserializer toggle while there is control-channel communication, or if a line fault occurs, the control-channel communication is corrupted. In the event of a missed or delayed acknowledge (~1ms due to control channel timeout), the μ C should assume there was an error in the packet transmission or response. In base mode, the μ C must keep the UART Tx/Rx lines high no more than four bit times between bytes in a packet. Keep the UART Tx/Rx lines high for at least 16 bit times before starting to send a new packet.

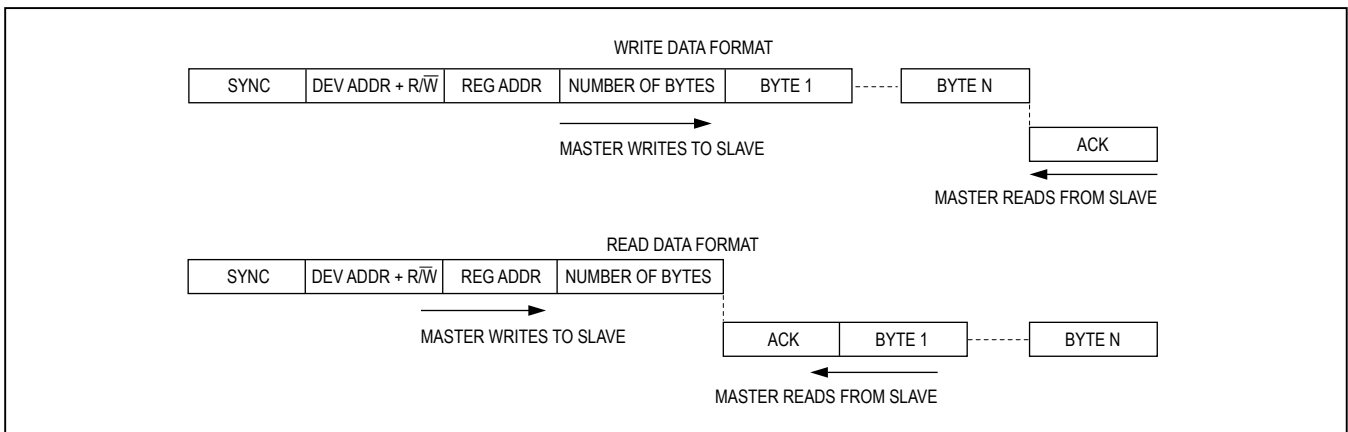

Figure 41. GMSL UART Protocol for Base Mode

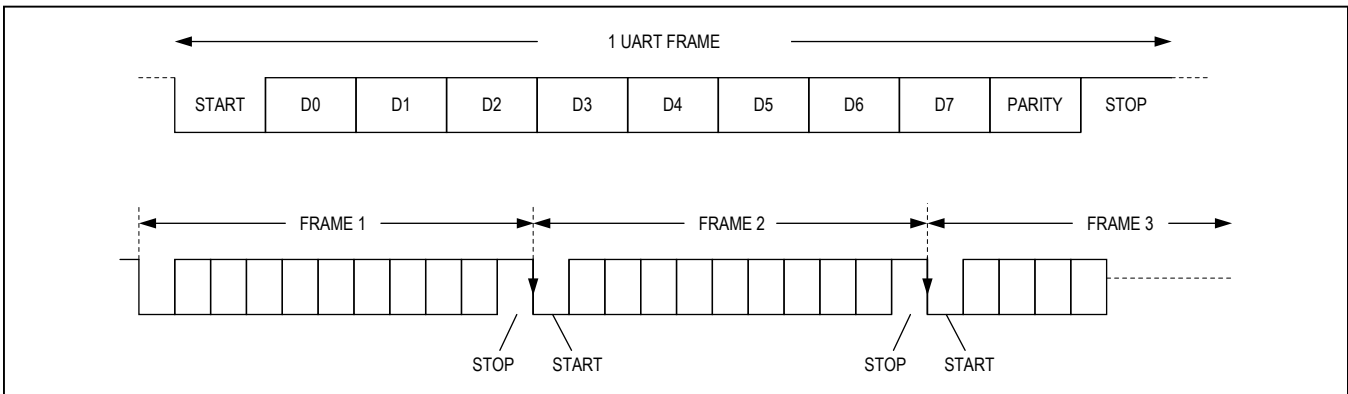

Figure 42. GMSL UART Data Format for Base Mode

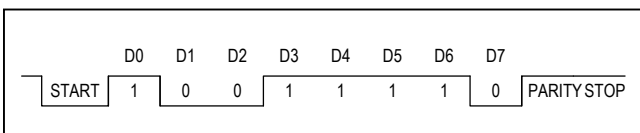

Figure 43. SYNC Byte (0x79)

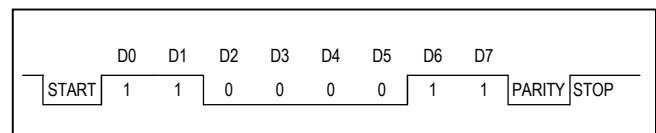

Figure 44. ACK Byte (0xC3)

As shown in Figure 45, the remote-side device converts packets going to or coming from the peripherals from UART format to I²C format and vice versa. The remote device removes the byte number count and adds or receives the ACK between the data bytes of I²C. The I²C bit rate is the same as the UART bit rate.

Interfacing Command-Byte-Only I²C Devices with UART

The deserializers' UART-to-I²C conversion can interface with devices that do not require register addresses, such as the MAX7324 GPIO expander. In this mode, the I²C master ignores the register address byte and directly reads/writes the subsequent data bytes (Figure 46). Change the communication method of the I²C master using the I2CMETHOD bit. I2CMETHOD = 1 sets command-byte-only mode, while I2CMETHOD = 0 sets normal mode where the first byte in the data stream is the register address.

UART Bypass Mode

In bypass mode, the deserializers ignore UART commands from the μC and the μC communicates with the peripherals directly using its own defined UART protocol. The μC cannot access the serializer/deserializer's registers in this

mode. Peripherals accessed through the forward control channel using the UART interface need to handle at least one pixel clock period ±10ns of jitter due to the asynchronous sampling of the UART signal by pixel clock. Set MS = high in the serializer to put the control channel into bypass mode. For applications with the μC connected to the deserializer, set the MS pin on the deserializer. There is a 1ms wait time between switching MS and the bypass control channel being active; do not send a UART command during this time. There is no delay time when switching to bypass mode when the μC is connected to the serializer. Although MS on either the serializer or deserializer sets the control-channel byass mode, only the local-side device (connected to the μC) should be used set bypass mode. Do not switch MS while a UART command is being sent. Do not send a logic-low value longer than 100μs to ensure proper GPO functionality. Bypass mode accepts bit rates down to 10kbps in either direction. See the *GPO/GPI Control* section for GPI functionality limitations. The control-channel data pattern should not be held low longer than 100μs if GPI control is used.

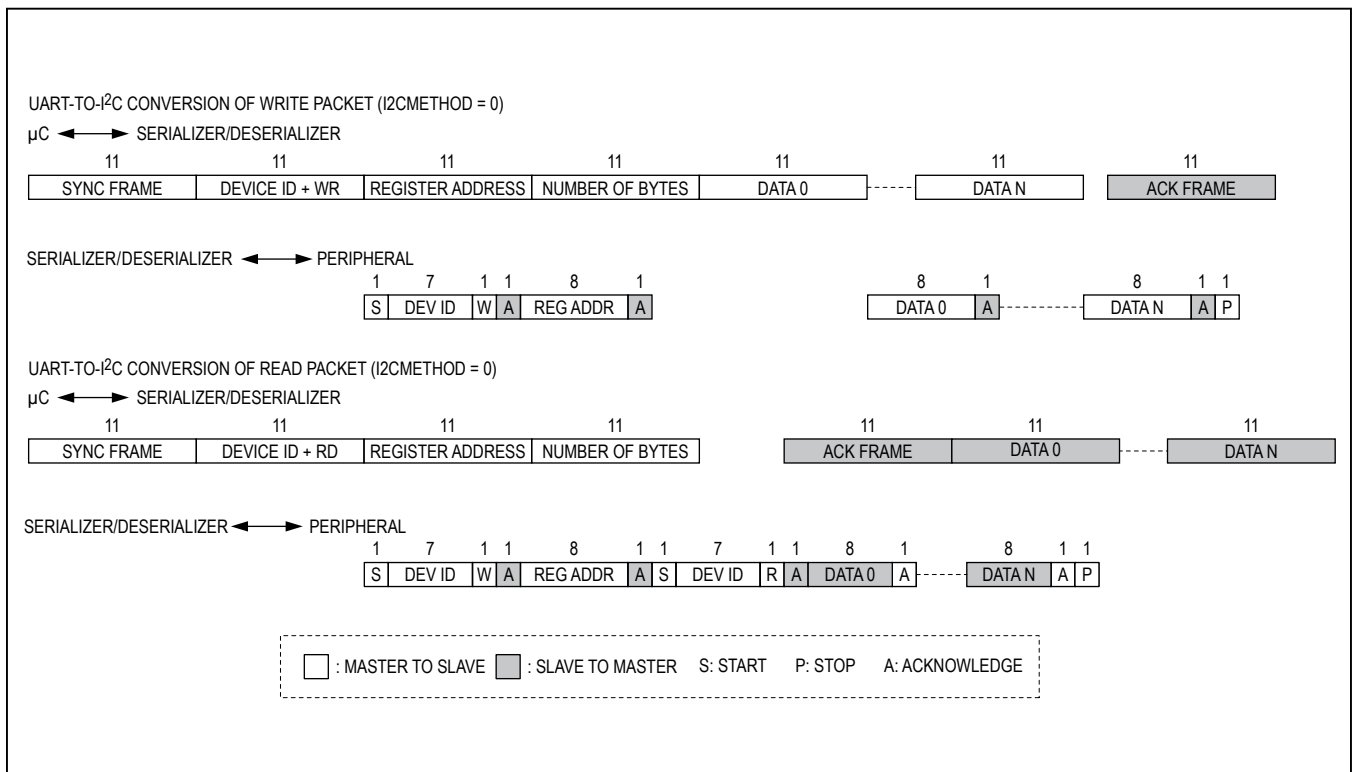

Figure 45. Format Conversion Between GMSL UART and I²C with Register Address (I2CMETHOD = 0)

I²C Interface

In I²C-to-I²C mode, the deserializer’s control-channel interface sends and receives data through an I²C-compatible 2-wire interface. The interface uses a serial-data line (SDA) and a serial-clock line (SCL) to achieve bidirectional communication between master and slave(s). A μC master initiates all data transfers to and from the device and generates the SCL clock that synchronizes the data transfer. When an I²C transaction starts on the local-side device’s control-channel port, the remote-side

device’s control-channel port becomes an I²C master that interfaces with remote-side I²C peripherals. The I²C master must accept clock stretching that is imposed by the deserializer (holding SCL low). The SDA and SCL lines operate as both an input and an open-drain output. Pullup resistors are required on SDA and SCL. Each transmission consists of a START condition (Figure 6) sent by a master, followed by the device’s 7-bit slave address plus a R/W bit, a register address byte, one or more data bytes, and finally a STOP condition.

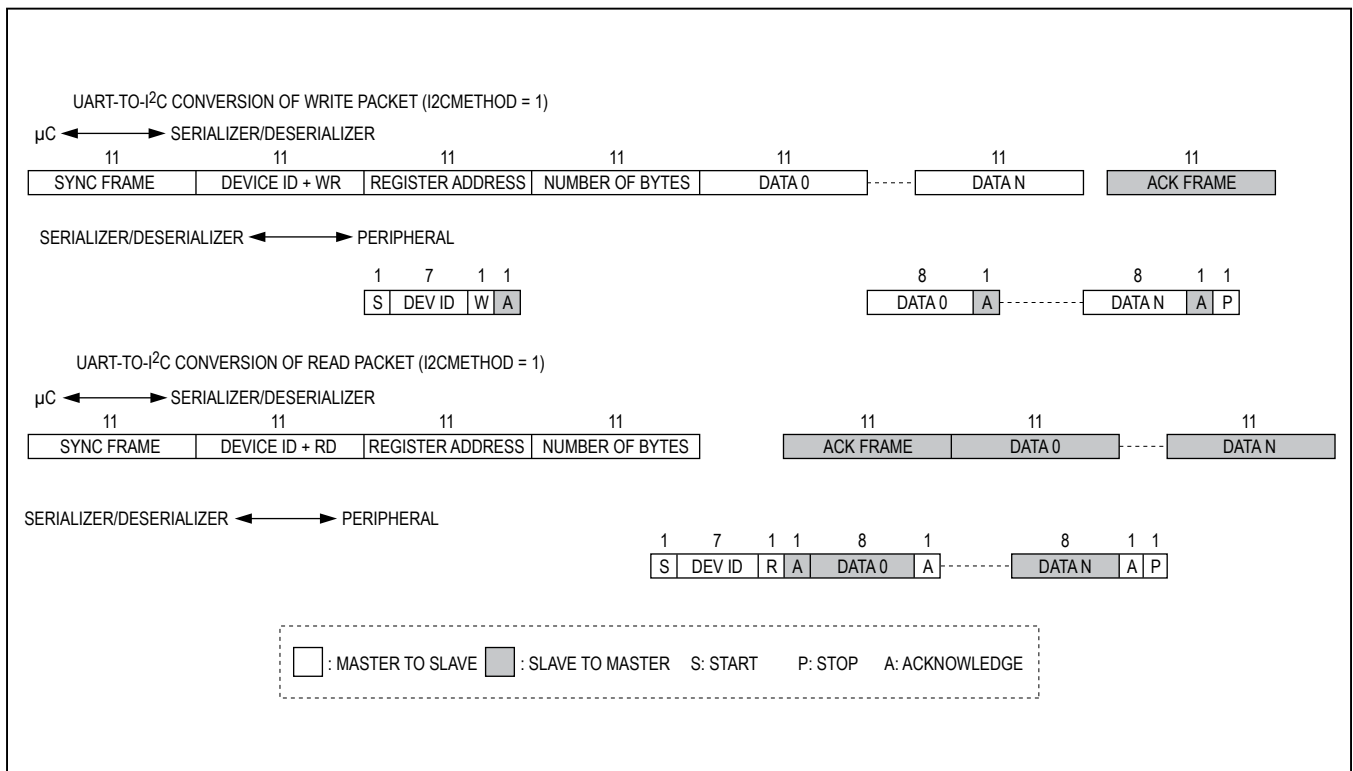

Figure 46. Format Conversion Between GMSL UART and I²C without Register Address (I²CMETHOD = 1)

START and STOP Conditions

Both SCL and SDA remain high when the interface is not busy. A master signals the beginning of a transmission with a START (S) condition by transitioning SDA from high to low while SCL is high (see Figure 47). When the master has finished communicating with the slave, it issues a STOP (P) condition by transitioning SDA from low to high while SCL is high. The bus is then free for another transmission.

Bit Transfer

One data bit is transferred during each clock pulse (Figure 48). The data on SDA must remain stable while SCL is high.

Acknowledge

The acknowledge bit is a clocked 9th bit that the recipient uses to handshake receipt of each byte of data (Figure 49). Thus, each byte transferred effectively requires 9 bits. The master generates the 9th clock pulse, and the recipient pulls down SDA during the acknowledge clock pulse. The SDA line is stable low during the high period of the clock pulse. When the master is transmitting to the slave device, the slave device generates the acknowledge bit because the slave device is the recipient. When the slave device is transmitting to the master, the master generates the acknowledge bit because the master is the recipient. The device generates an acknowledge even when the forward control channel is not active. To prevent acknowledge generation when the forward control channel is not active, set the I2CLOCKACK bit low.

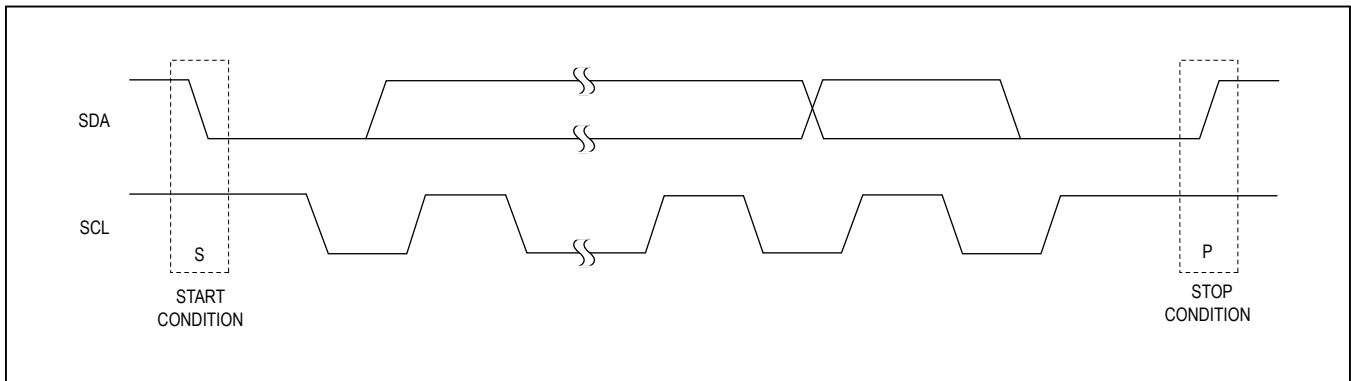

Figure 47. START and STOP Conditions

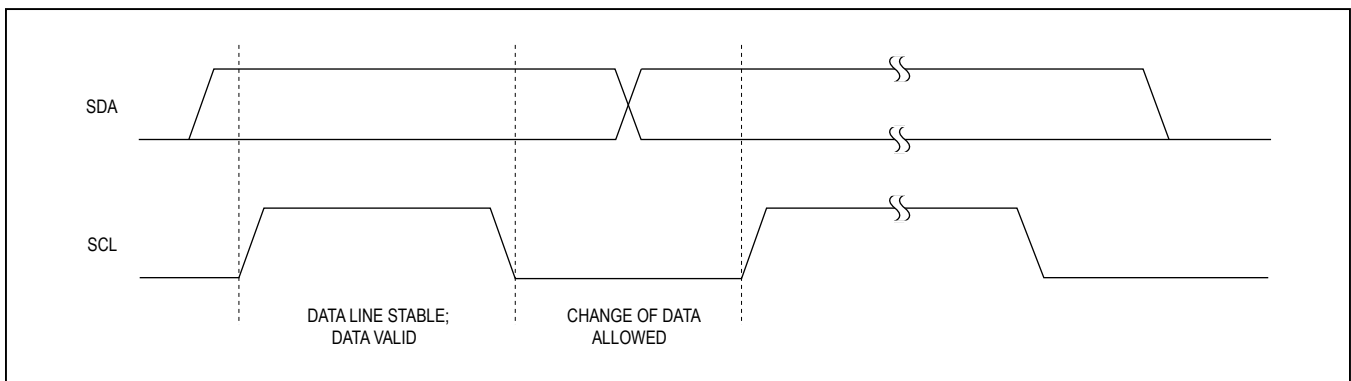

Figure 48. Bit Transfer

Slave Address

The deserializers have 7-bit long slave addresses. The bit following a 7-bit slave address is the R/W bit, which is

low for a write command and high for a read command. The slave address for the deserializer is XX01XXX1 for read commands and XX01XXX0 for write commands. See [Figure 50](#).

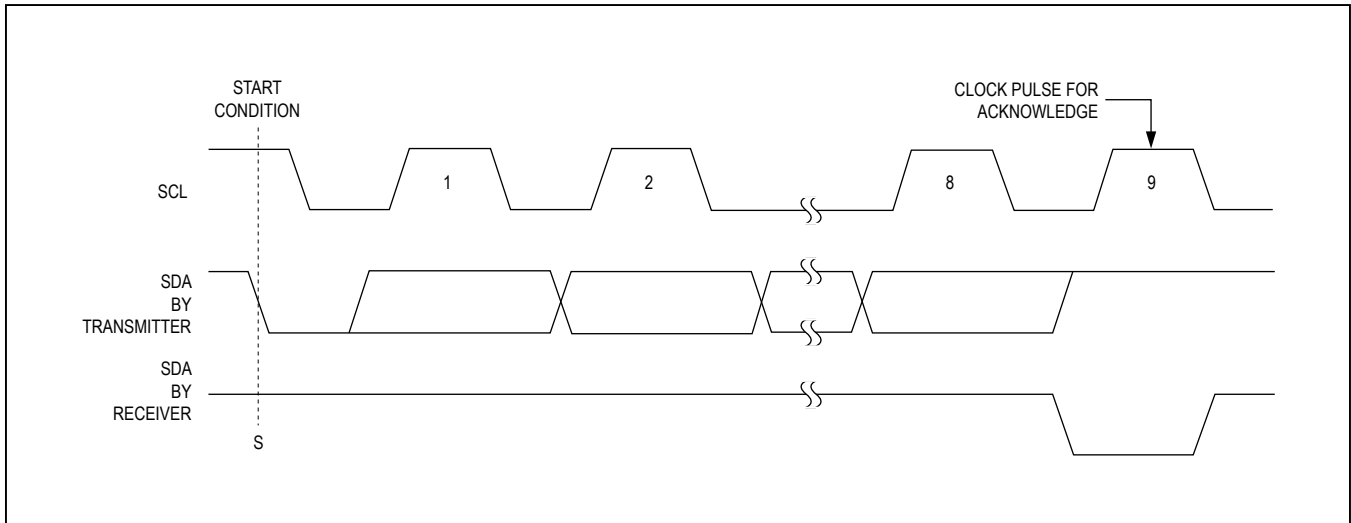

Figure 49. Acknowledge

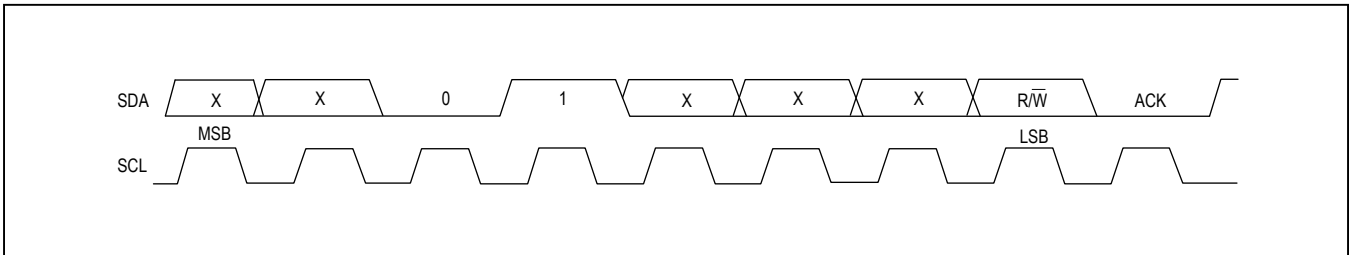

Figure 50. Slave Address

Bus Reset

The device resets the bus with the I2C START condition for reads. When the R/W bit is set to 1, the deserializers transmit data to the master, thus the master is reading from the device.

Format for Writing

Writes to the deserializers comprise the transmission of the slave address with the R/W bit set to zero, followed by at least 1 byte of information. The first byte of information is the register address or command byte. The register

address determines which register of the device is to be written by the next byte, if received. If a STOP (P) condition is detected after the register address is received, the device takes no further action beyond storing the register address (Figure 51). Any bytes received after the register address are data bytes. The first data byte goes into the register selected by the register address, and subsequent data bytes go into subsequent registers (Figure 52). If multiple data bytes are transmitted before a STOP condition, these bytes are stored in subsequent registers because the register addresses autoincrement.

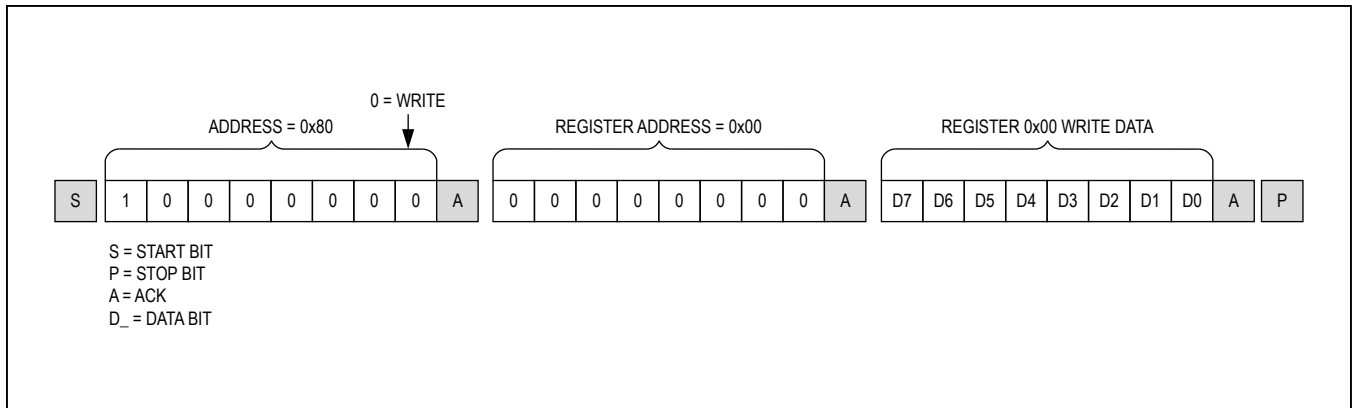

Figure 51. Format for I2C Write

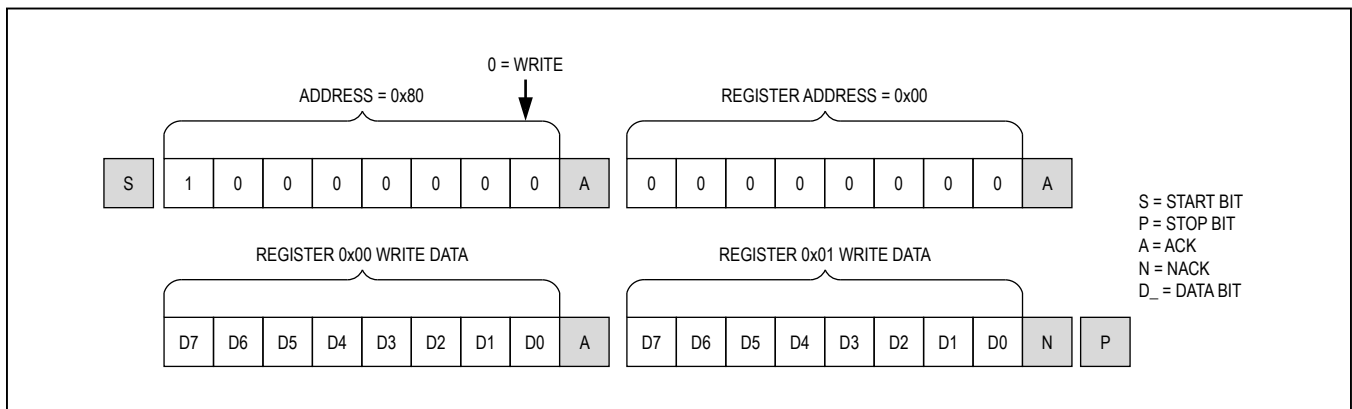

Figure 52. Format for Write to Multiple Registers

Format for Reading

The deserializers are read using the internally stored register address as an address pointer, the same way the stored register address is used as an address pointer for a write. The pointer autoincrements after each data byte is read using the same rules as for a write. Thus, a read is initiated by first configuring the register address by performing a write (Figure 53). The master can now read consecutive bytes from the device, with the first data byte being read from the register address pointed by the previously written register address. Once the master sends a NACK, the device stops sending valid data.

I²C Communication with Remote-Side Devices

The deserializers support I²C communication with a peripheral on the remote side of the communication link using SCL clock stretching. While multiple masters can reside on either side of the communication link, arbitration is not provided. The connected masters need to support SCL clock stretching. The remote-side I²C bit rate range must be set according to the local-side I²C bit rate. Supported remote-side bit rates can be found in Table 10. Set the I2CMSTBT (register 0x1C) to set the remote I²C bit rate. If using a bit rate different from 400kbps, local- and remote-side I²C setup and hold times should be adjusted by setting the I2CSLVSH register settings on both sides.

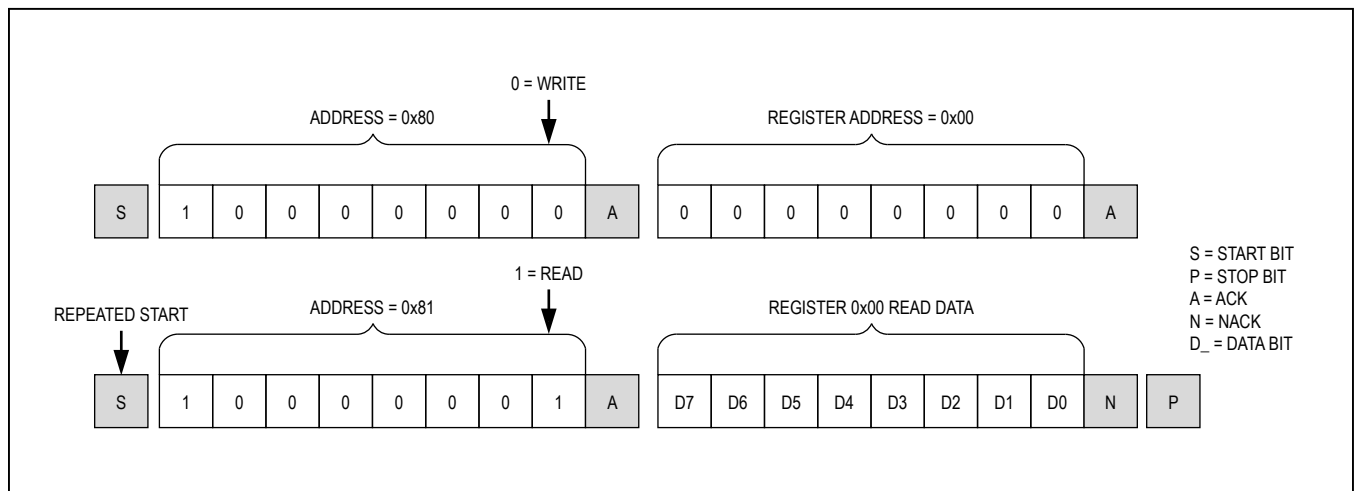

Figure 53. Format for I²C Read

Table 10. I²C Bit-Rate Ranges

LOCAL BIT RATE	REMOTE BIT RATE RANGE	I2CMSTBT SETTING
f > 50kbps	Up to 1Mbps	Any
20kbps > f > 50kbps	Up to 400kbps	Up to 110
f < 20kbps	Up to 10kbps	000

I²C Address Translation

The deserializers support I²C address translation for up to two device addresses. Use address translation to assign unique device addresses to peripherals with limited I²C addresses. Source addresses (address to translate from) are stored in registers 0x18 and 0x1A. Destination addresses (address to translate to) are stored in registers 0x19 and 0x1B.

In a multilink situation where there are multiple deserializers and/or peripheral devices connected to these serializers, the deserializers support broadcast commands to control these multiple devices. Select an unused device address to use as a broadcast device address. Program all the remote-side serializer devices to translate the broadcast device address (source address stored in registers 0x0F, 0x11) to the peripherals' address (destination address stored in registers 0x10, 0x12). Any commands sent to the broadcast address (selected unused address) are sent to all deserializers and/or peripheral devices connected to the deserializers whose addresses match the translated broadcast address.

GPO/GPI Control

GPO on the serializer follows GPI transitions on the deserializer. This GPO/GPI function can be used to transmit signals such as a frame sync in a surround-view camera system. The GPI-to-GPO delay is 0.35ms max. Keep time between GPI transitions to a minimum 0.35ms. This includes transitions from the other deserializer in coax splitter mode. Bit D4 of register 0x06 in the deserializer stores the GPI input state. GPO is low after power-up. The μ C can set GPO by writing to the SETGPO register bit. Do not send a logic-low value on the deserializer RX/SDA input (UART mode) longer than 100 μ s in either base or bypass mode to ensure proper GPO/GPI functionality. GPO/GPI commands will override and corrupt an I²C/UART command in progress.

Line Equalizer

The deserializer includes an adjustable line equalizer to further compensate cable attenuation at high frequencies. The cable equalizer has 11 selectable levels of compensation from 2.1dB to 13dB (Table 11). To select other equalization levels, set the corresponding register bits in the deserializer (0x05 D[3:0]). Use equalization in the

deserializer, together with preemphasis in the serializer, to create the most reliable link for a given cable.

HS/VS/DE Tracking

The deserializer has tracking to filter out HS/VS/DE bit or packet errors. HS/VS/DE tracking is on by default when the device is in high-bandwidth mode (BWS = open), and off by default when in 24-bit or 32-bit mode (BWS = low or high). Set/clear HVTREN (D6 of register 0x15) to enable/disable HS/VS tracking. Set/clear DETREN (D5 of register 0x15) to enable/disable DE tracking. By default, the device uses a partial and full periodic tracking of HS/DE. Set HVTRMODE = 0 (D4 of register 0x15) to disable full periodic tracking. HS/VS/DE tracking can be turned on in 24-bit and 32-bit modes to track and correct against bit errors in HS/VS/DE link bits.

Serial Input

The device can receive serial data from two kinds of cable: 100 Ω twisted pair and 50 Ω coax. (Contact the factory for devices compatible with 75 Ω cables).

Table 11. Cable Equalizer Boost Levels

BOOST SETTING (0x05 D[3:0])	TYPICAL BOOST GAIN (dB)
0000	2.1
0001	2.8
0010	3.4
0011	4.2
0100	5.2 Power-up default when EQS is set high
0101	6.2
0110	7
0111	8.2
1000	9.4
1001	10.7 Power-up default when EQS is set low
1010	11.7
1011	13

Coax Splitter Mode

In coax mode, OUT+ and OUT- of the serializer are active. This enables the use as a 1:2 splitter (Figure 54). In coax mode, connect OUT+ to IN+ of the deserializer. Connect OUT- to IN- of the second deserializer. Control-channel data is broadcast from the serializer to both deserializers and their attached peripherals. Assign a unique address to send control data to one deserializer. Leave all unused IN_ pins unconnected, or connect them to ground through

50Ω and a capacitor for increased power-supply rejection. If OUT- is not used, connect OUT- to AVDD through a 50Ω resistor (Figure 55). When there are μCs at the serializer, and at each deserializer, only one μC can communicate at a time. Disable forward and reverse channel links according to the communicating deserializer connection to prevent contention in I²C-to-I²C mode. Use ENREVP or ENREVN register bits to disable/enable the control channel link. In UART mode, the serializer provides arbitration of the control-channel link.

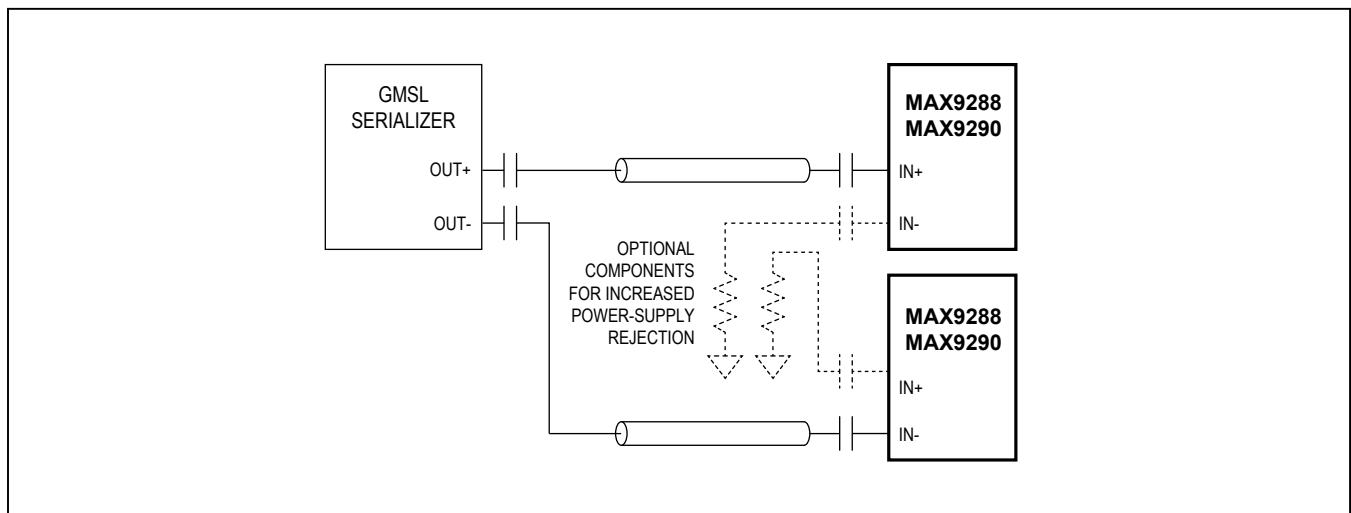

Figure 54. 2:1 Coax Splitter Connection Diagram

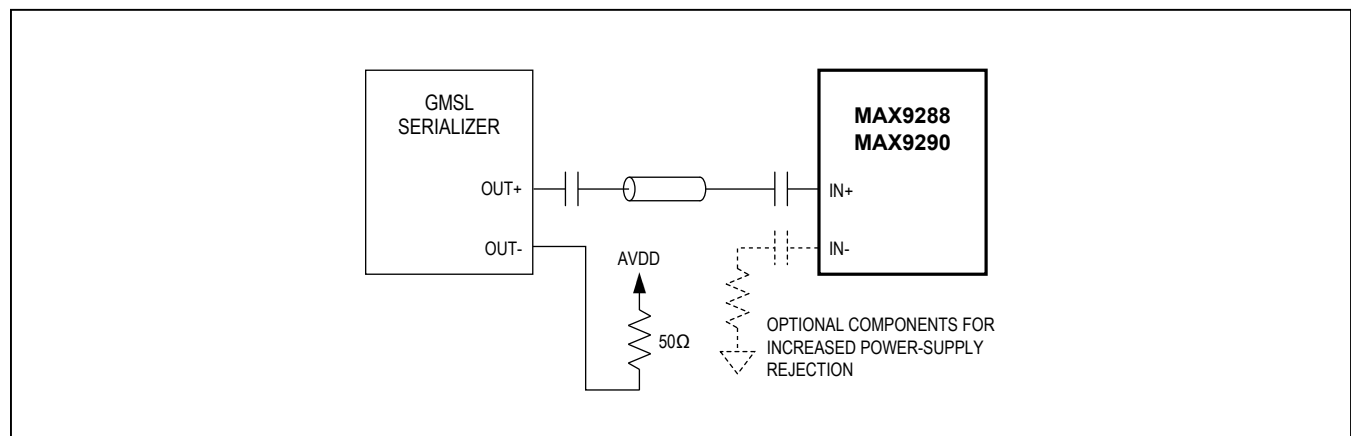

Figure 55. Coax Connection Diagram

Table 12. Configuration Input Map

CX/TP	FUNCTION
High	Coax+ input. 7-bit device address is XXXXXX0 (bin).
Mid	Coax- input. 7-bit device address is XXXXXX1 (bin).
Low	Twisted-pair input. 7-bit device address is XXXXXX0 (bin).

Cable Type Configuration Input

CX/TP determine the power-up state of the serial input. In coax mode, CX/TP also determine which coax input is active, along with the default device address (Table 12).

Color Lookup Tables

The deserializer includes three color lookup tables (LUT) to support automatic translation of pixel values. The LUT can be used for RGB666, RGB888, and user-defined generic 8-bit CSI-2 outputs. This feature can be used for color gamma correction, brightness/contrast or for other purposes. There are three lookup tables, each 8 bits wide and 256 entries deep, enabling a 1-to-1 translation of 8-bit input values to any 8-bit output value for each color (24 bits total).

Programming and Verifying LUT Data

The μC must set the LUTPROG register bit to 1 before programming and verifying the tables. To program a LUT, the μC generates a write packet with register address set to the assigned register address for respective LUT (0x7D, 0x7E, or 0x7F). The deserializer writes data in the packet to the respective LUT starting from the LUT address location set in the LUTADDR register. Successive bytes in the data packet are written to the next LUT address location; however, each new data-packet write starts from

the address location stored in the LUTADDR register. Use 0x00 for LUTADDR and 0x00 as the number of bytes field in UART packet, when writing a 256-byte data block, because 8-bit-wide number of bytes field cannot normally represent 9-bit wide “256” value. There is no number of bytes field in I²C-to-I²C modes.

To read back the contents of an LUT, the μC generates a read packet with register address set to the assigned register address for respective LUT (0x7D, 0x7E, or 0x7F). The deserializer outputs read data from the respective LUT starting from the LUT address location set in the LUT_ADDR register. Similar to the write operation, use 0x00 for LUTADDR and 0x00 as the number of bytes field in UART packet, when reading a 256-byte data block.

LUT Color Translation

After power-up or going out of sleep or power-down modes, LUT translation is disabled and LUT contents are unknown. After program and verify operations are finished, in order to enable LUT translations, set the LUTPROG bit to 0 and set the respective LUT enable bits (RED_LUT_EN, GRN_LUT_EN, BLU_LUT_EN) to 1 to enable the desired LUT translation function. Only the selected colors are translated by the LUT (the other colors are not touched). The μC does not need to fill in all three color lookup tables if all three color translations are not needed.

After a pixel is deserialized, decoded, and decrypted (if necessary), it is segmented into its color components red, green, and blue (RGB) according to Table 13 and Figure 56. If LUT translation is enabled, each 8-bit pretranslation color value is used as address to the respective LUT table to look up the corresponding (translated) 8-bit color value.

Table 13. Pixel Data Format

DOUT [5:0]	DOUT [11:6]	DOUT [17:12]	DOUT18	DOUT19	DOUT20	DOUT [22:21]	DOUT [24:23]	DOUT [26:25]
R[5:0]	G[5:0]	B[5:0]	HS	VS	DE	R[7:6]	G[7:6]	B[7:6]

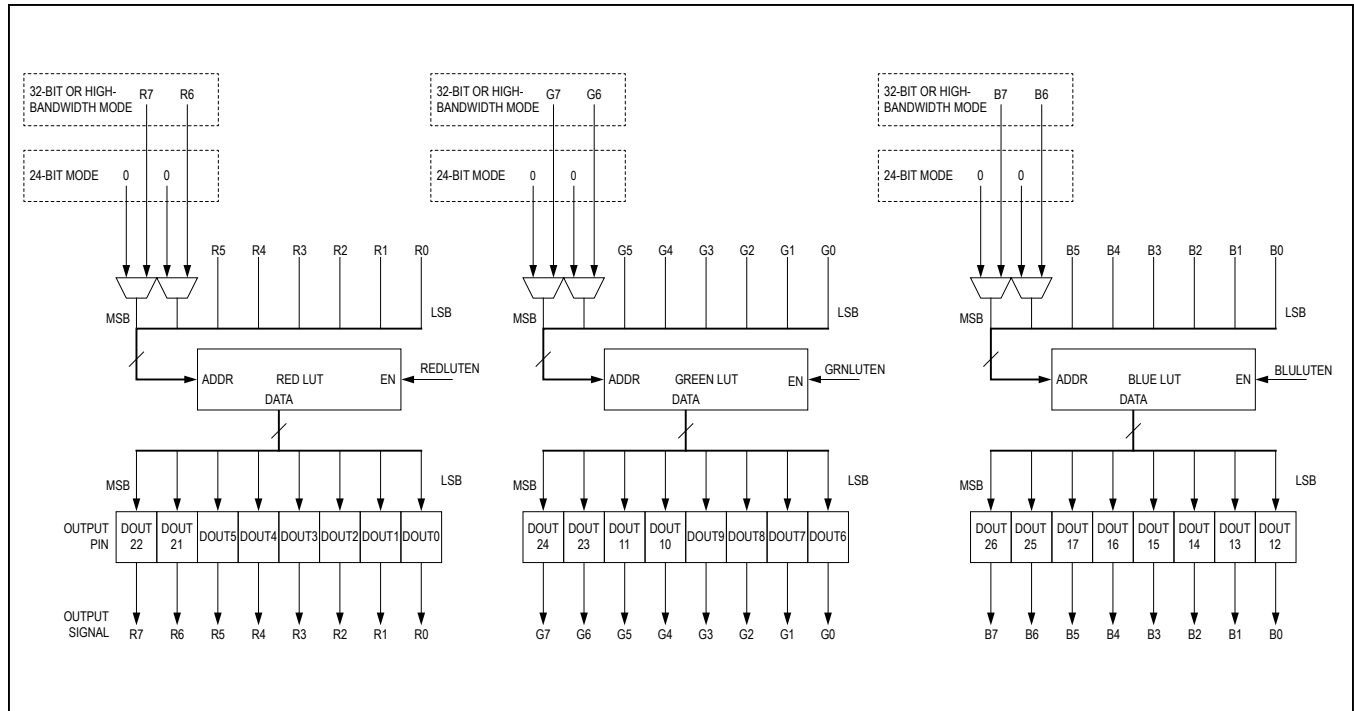

Figure 56. LUT Dataflow

LUT Bit Width

In 32-bit and high-bandwidth modes, 24 bits are available for color data (8 bits per color) and each LUT is used for 8-bit to 8-bit color translation. In 24-bit mode, the deserializer can receive only up to 18-bit color (6 bits per color). The LUT tables can translate from 6-bit to 6-bit, using the first 64 locations (0x00 to 0x3F). Program the MSB 2 bits of each LUT value to 00. Alternatively, program full 8-bit values to each LUT for 6-bit to 8-bit color translation.

Recommended LUT Program Procedure

- 1) Write LUTPROG = 1 to register 0x7C. Keep BLULUTEN = 0, GRNLUTEN = 0, REDLUTEN = 0 (write 0x08 to register 0x7C).
- 2) Write contents of red LUT with a single write packet. For 24-bit RGB, use 0x7D as register address and 0x00 as number of bytes (UART only) and write 256 bytes. For 18-bit RGB, use 0x7D as register address

and 0x40 as number of bytes (UART only) and write 64 bytes. (Optional: Multiple write packets can be used if LUTADDR is set before each LUT write packet.)

- 3) Read contents of red LUT and verify that they are correct. Use the same register address and number of bytes used in the previous step.
- 4) Repeat steps 2 and 3 for the green LUT, using 0x7E as the register address.
- 5) Repeat steps 2 and 3 for the blue LUT, using 0x7F as the register address.
- 6a) To finish the program and verify routine, without enabling the LUT color translation, write LUTPROG = 0 (write 0x00 to register 0x7C).
- 6b) To finish the program and verify routine, and start LUT color translation, write LUTPROG = 1, BLULUTEN = 1, GRNLUTEN = 1, REDLUTEN = 1 (write 0x07 to register 0x7C).

High-Immunity Reverse Control-Channel Mode

The deserializer contains a high-immunity reverse control-channel mode, which has increased robustness at half the bit rate over the standard GMSL reverse control-channel link (Table 14). Set HIM on the serializer and deserializer to use high-immunity mode at power-up. Set the HIGHIMM bit high in both the serializer and deserializer to enable high-immunity mode at any time after power-up. Set the HIGHIMM bit low in both the serializer and deserializer to use the legacy reverse control-channel mode. The deserializer reverse channel mode is not available for 500µs/1.92ms after the reverse control-channel mode is changed through the serializer/deserializer’s HIGHIMM bit setting, respectively. The user must set HIM or the HIGHIMM bits to the same value for proper reverse control-channel communication.

In high-immunity mode, Set HPFTUNE = 00 in the equalizer, if the serial bit rate = [pixel clock x 30 (BWS = low or open) or 40 (BWS = high)] is larger than 1Gbps when BWS is low or high. When BWS = open, set HPFTUNE = 00 when the serial bit rate is larger than 2GBps. In addition, use 47nF AC-coupling capacitors. Note that legacy reverse control-channel mode may not function when using 47nF AC-coupling capacitors.

By default, high-immunity mode uses a 500kbps bit rate. Set REVFAST =1 (D7 in register 0x1A in the serializer and register 0x11 in the deserializer) in both devices to use a 1Mbps bit rate. Certain limitations apply when using the fast high-immunity mode (Table 15).

Sleep Mode

The deserializers have sleep mode to reduce power consumption. The devices enter or exit sleep mode by a command from a remote µC using the control channel. Set the SLEEP bit to 1 to initiate sleep mode. Entering sleep mode resets the HDCP registers, but not the configuration registers. The deserializer sleeps after serial link inactivity or 8ms (whichever arrives first) after setting its SLEEP = 1. See the [Link Startup Procedure](#) section for details on waking up the device for different µC and starting conditions.

To wake up from the local side, send an arbitrary control-channel command to the deserializer, wait for 5ms for the chip to power up, and then write 0 to SLEEP register bit to make the wake-up permanent. To wake up from the remote side, enable serialization. The deserializer detects the activity on serial link and then when it locks, it automatically sets its SLEEP register bit to 0.

Power-Down Mode

The deserializers have a power-down mode that further reduces power consumption compared to sleep mode. Set PWDN low to enter power-down mode. In power-down, the parallel outputs remain high impedance. Entering power-down resets the device’s registers. Upon exiting power-down, the state of external pins ADD0–ADD2, CX/TP, I2CSEL, DRS, EQS, HIM/CNTL1, and BWS are latched.

Table 14. Reverse Control-Channel Modes

HIGHIMM BIT OR SD/HIM PIN SETTING	REVFAST BIT	REVERSE CONTROL-CHANNEL MODE	MAX UART/I2C BIT RATE (kbps)
Low (0)	X	Legacy reverse control-channel mode (compatible with all GMSL devices)	1000
High (1)	0	High-immunity mode	500
	1	Fast high-immunity mode	1000

X = Don’t care.

Table 15. Fast High-Immunity Mode Requirements

BWS SETTING	ALLOWED PIXEL CLOCK FREQUENCY (MHz)
Low	> 41.66
High	> 30
Open	> 83.33

Fast high-immunity mode requires DRS = 0.

Configuration Link

The control channel can operate in a low-speed mode called configuration link in the absence of a clock input. This allows a microprocessor to program configuration registers before starting the video link. An internal oscillator provides the clock for the configuration link. Set CLINKEN = 1 on the serializer to enable configuration link. Configuration link is active until the video link is

enabled. The video link overrides the configuration link and attempts to lock when SEREN = 1.

Link Startup Procedure

Table 16 lists the startup procedure for image-sensing applications. The control channel is available after the video link or the configuration link is established. If the deserializer powers up after the serializer, the control channel becomes unavailable for 2ms after power-up.

Table 16. Startup Procedure for Image-Sensing Applications (CDS = High, Figure 58)

NO.	µC	SERIALIZER		DESERIALIZER
		(AUTOSTART ENABLED)	(AUTOSTART DISABLED)	
—	µC connected to deserializer.	Sets all configuration inputs.	Sets all configuration inputs.	Sets all configuration inputs.
1	Powers up.	Powers up and loads default settings. Establishes video link when valid PCLK available.	Powers up and loads default settings. Goes to sleep after 8ms.	Powers up and loads default settings. Locks to video link signal if available.
2	Writes deserializer configuration bits and gets an acknowledge.			Configuration changed from default settings.
3	Wakes up the serializer by sending dummy packet, and then writing SLEEP = 0 within 8ms. May not get an acknowledge (or gets a dummy acknowledge) if not locked.		Wakes up.	
4	Writes serializer configuration bits. May not get an acknowledge (or gets a dummy acknowledge) if not locked.	Configuration changed from default settings.		
5	If not already enabled, sets SEREN = 1, gets an acknowledge and waits for serial link to be established (~3ms).	Establishes video link when valid PCLK available (if not already enabled).		Locks to video link signal (if not already locked).
6	Begin sending video data to input.	Video data serialized and sent across serial link.		Video data received and deserialized.

High-Bandwidth Digital Content Protection (HDCP)

Note: The explanation of HDCP operation in this data sheet is provided as a guide for general understanding. Implementation of HDCP in a product must meet the requirements given in the HDCP System v1.3 Amendment for GMSL, which is available from DCP.

HDCP has two main phases of operation, authentication and the link integrity check. The μC starts authentication by writing to the START_AUTHENTICATION bit in the GMSL serializer. The GMSL serializer generates a 64-bit random number. The host μC first reads the 64-bit random number from the GMSL serializer and writes it to the deserializer. The μC then reads the GMSL serializer public key selection vector (AKSV) and writes it to the deserializer. The μC then reads the deserializer KSV (BKSV) and writes it to the GMSL serializer. The μC begins checking BKSV against the revocation list. Using the cipher, the GMSL serializer and deserializer calculate a 16-bit response value, R_0 and R_0' , respectively. The GMSL amendment for HDCP reduces the 100ms minimum wait time allowed for the receiver to generate R_0' (specified in HDCP rev 1.3) to 128 pixel clock cycles in the GMSL amendment.

There are two response-value comparison modes, internal comparison and μC comparison. Set EN_INT_COMP = 1 to select internal comparison mode. Set EN_INT_COMP = 0 to select μC comparison mode. In internal comparison mode, the μC reads the deserializer response R_0' and writes it to the GMSL serializer. The GMSL serializer compares R_0' to its internally generated response value R_0 , and sets R0_RI_MATCHED. In μC comparison mode, the μC reads and compares the R_0/R_0' values from the GMSL serializer/deserializer.

During response-value generation and comparison, the host μC checks for a valid BKSV (having 20 1s and 20 0s is also reported in BKSV_INVALID) and checks BKSV against the revocation list. If BKSV is not on the list and the response values match, the host authenticates the link. If the response values do not match, the μC resamples the response values (as described in HDCP rev 1.3, Appendix C). If resampling fails, the μC restarts authentication by setting the RESET_HDCP bit in the GMSL serializer. If BKSV appears on the revocation list, the host cannot transmit data that requires protection. The host knows when the link is authenticated and decides when to output data requiring protection. The μC performs a link integrity check every 128 frames or every 2s \pm 0.5s. The GMSL serializer/deserializer generate response values

every 128 frames. These values are compared internally (internal comparison mode) or can be compared in the host μC .

In addition, the GMSL serializer/deserializer provide response values for the enhanced link verification. Enhanced link verification is an optional method of link verification for faster detection of loss-of-synchronization. For this option, the GMSL serializer and deserializer generate 8-bit enhanced link-verification response values (PJ and PJ') every 16 frames. The host must detect three consecutive PJ/PJ' mismatches before resampling.

Encryption Enable

The GMSL link transfers either encrypted or nonencrypted data. To encrypt data, the host μC sets the encryption enable (ENCRYPTION_ENABLE) bit in both the GMSL serializer and deserializer. The μC must set ENCRYPTION_ENABLE in the same VSYNC cycle in both the GMSL serializer and deserializer (no internal VSYNC falling edges between the two writes). The same timing applies when clearing ENCRYPTION_ENABLE to disable encryption.

Note: ENCRYPTION_ENABLE enables/disables encryption on the GMSL irrespective of the content. To comply with HDCP, the μC must not allow content requiring encryption to cross the GMSL unencrypted.

The μC must complete the authentication process before enabling encryption. In addition, encryption must be disabled before starting a new authentication session.

Synchronization of Encryption

The video vertical sync (VSYNC) synchronizes the start of encryption. Once encryption has started, the GMSL generates a new encryption key for each frame and each line, with the internal falling edge of VSYNC and HSYNC. Rekeying is transparent to data and does not disrupt the encryption of video or audio data.

Repeater Support

The GMSL serializer/deserializer include features to build an HDCP repeater. An HDCP repeater receives and decrypts HDCP content and then encrypts and transmits on one or more downstream links. A repeater can also use decrypted HDCP content (e.g., to display on a screen). To support HDCP repeater-authentication protocol, the deserializer has a REPEATER register bit. This register bit must be set to 1 by a μC (most likely on the repeater module). Both the GMSL serializer and deserializer use SHA-1 hash-value calculation over the assembled KSV lists. HDCP GMSL links support a maximum of 15 receivers (total number including the ones in repeater modules).

If the total number of downstream receivers exceeds 14, the μC must set the MAX_DEVS_EXCEEDED register bit when it assembles the KSV list.

HDCP Authentication Procedures

The GMSL serializer generates a 64-bit random number exceeding the HDCP requirement. The GMSL serializer/deserializer internal one-time programmable (OTP) memories contain a unique HDCP keyset programmed at the factory. The host μC initiates and controls the HDCP authentication procedure. The GMSL serializer and deserializer generate HDCP authentication response values for the verification of authentication. Use the following

procedures to authenticate the HDCP GMSL encryption (refer to the HDCP 1.3 Amendment for GMSL for details). The μC must perform link integrity checks while encryption is enabled (see Table 17). Any event that indicates that the deserializer has lost link synchronization should retrigger authentication. The μC must first write 1 to the RESET_HDCP bit in the GMSL serializer before starting a new authentication attempt.

HDCP Protocol Summary

Table 17, Table 18, and Table 19 list the summaries of the HDCP protocol. These tables serve as an implementation guide only. Meet the requirements in the GMSL amendment for HDCP to be in full compliance.

Table 17. Startup, HDCP Authentication, and Normal Operation (Deserializer is Not a Repeater)—First Part of the HDCP Authentication Protocol

NO.	μC	HDCP GMSL SERIALIZER	HDCP GMSL DESERIALIZER
1	Initial state after power-up.	Powers up waiting for HDCP authentication.	Powers up waiting for HDCP authentication.
2	Makes sure that A/V data not requiring protection (low-value content) is available at the GMSL serializer inputs (such as blue or informative screen). Alternatively, uses the FORCE_VIDEO and FORCE_AUDIO bits of the GMSL serializer to mask A/V data at the input of the GMSL serializer. Starts the link by writing SEREN = H or link starts automatically if AUTOS is low.	—	—
3	—	Starts serialization and transmits low-value content A/V data.	Locks to incoming data stream and outputs low-value content A/V data.
4	Reads the locked bit of the deserializer and makes sure the link is established.	—	—
5	Optionally writes a random-number seed to the GMSL serializer.	Combines seed with internally generated random number. If no seed provided, only internal random number is used.	—
6	If HDCP encryption is required, starts authentication by writing 1 to the START_AUTHENTICATION bit of the GMSL serializer.	Generates (stores) AN, and resets the START_AUTHENTICATION bit to 0.	—
7	Reads AN and AKSV from the GMSL serializer and writes to the deserializer.	—	Generates R0' triggered by the μC 's write of AKSV.
8	Reads the BKSV and REPEATER bit from the deserializer and writes to the GMSL serializer.	Generates R0, triggered by the μC 's write of BKSV.	—

Table 17. Startup, HDCP Authentication, and Normal Operation (Deserializer is Not a Repeater)—First Part of the HDCP Authentication Protocol (continued)

NO.	μC	HDCP GMSL SERIALIZER	HDCP GMSL DESERIALIZER
9	Reads the INVALID_BKSV bit of the GMSL serializer and continues with authentication if it is 0. Authentication can be restarted if it fails (set RESET_HDCP = 1 before restarting authentication).	—	—
10	Reads R0' from the deserializer and reads R0 from the GMSL serializer. If they match, continues with authentication; otherwise, retries up to two more times (optionally, GMSL serializer comparison can be used to detect if R0/R0' match). Authentication can be restarted if it fails (set RESET_HDCP = 1 before restarting authentication).	—	—
11	Waits for the VSYNC falling edge (internal to the GMSL serializer) and then sets the ENCRYPTION_ENABLE bit to 1 in the deserializer and GMSL serializer (if the FC is not able to monitor VSYNC, it can utilize the VSYNC_DET bit in the GMSL serializer).	Encryption enabled after the next VSYNC falling edge.	Decryption enabled after the next VSYNC falling edge.
12	Checks that BKSV is not in the Key Revocation list and continues if it is not. Authentication can be restarted if it fails. Note: Revocation list check can start after BKSV is read in step 8.	—	—
13	Starts transmission of A/V content that needs protection.	Performs HDCP encryption on high-value content A/V data.	Performs HDCP decryption on high-value content A/V data.

Table 18. Link Integrity Check (Normal)—Performed Every 128 Frames After Encryption is Enabled

NO.	μC	HDCP GMSL SERIALIZER	HDCP GMSL DESERIALIZER
1	—	Generates Ri and updates the RI register every 128 VSYNC cycles.	Generates Ri' and updates the RI' register every 128 VSYNC cycles.
2	—	Continues to encrypt and transmit A/V data.	Continues to receive, decrypt, and output A/V data.
3	Every 128 video frames (VSYNC cycles) or every 2s.	—	—
4	Reads RI from the GMSL serializer.	—	—
5	Reads RI' from the deserializer.	—	—
6	Reads RI again from the GMSL serializer and makes sure it is stable (matches the previous RI that it has read from the GMSL serializer). If RI is not stable, go back to step 5.	—	—
7	If RI matches RI', the link integrity check is successful; go back to step 3.	—	—
8	If RI does not match RI', the link integrity check fails. After the detection of failure of link integrity check, the FC makes sure that A/V data not requiring protection (low-value content) is available at the GMSL serializer inputs (such as blue or informative screen). Alternatively, the FORCE_VIDEO and FORCE_AUDIO bits of the GMSL serializer can be used to mask A/V data input of the GMSL serializer.	—	—
9	Writes 0 to the ENCRYPTION_ENABLE bit of the GMSL serializer and deserializer.	Disables encryption and transmits low-value content A/V data.	Disables decryption and outputs low-value content A/V data.
10	Restarts authentication by writing 1 to the RESET_HDCP bit followed by writing 1 to the START_AUTHENTICATION bit in the GMSL serializer.	—	—

Table 19. Optional Enhanced Link Integrity Check—Performed Every 16 Frames After Encryption is Enabled

NO.	μC	HDCP GMSL SERIALIZER	HDCP GMSL DESERIALIZER
1	—	Generates PJ and updates the PJ register every 16 VSYNC cycles.	Generates PJ' and updates the PJ' register every 16 VSYNC cycles.
2	—	Continues to encrypt and transmit A/V data.	Continues to receive, decrypt, and output A/V data.
3	Every 16 video frames, reads PJ from the GMSL serializer and PJ' from the deserializer.	—	—
4	If PJ matches PJ', the enhanced link integrity check is successful; go back to step 3.	—	—
5	If there is a mismatch, retry up to two more times from step 3. Enhanced link integrity check fails after 3 mismatches. After the detection of failure of enhanced link integrity check, the μC makes sure that A/V data not requiring protection (low-value content) is available at the GMSL serializer inputs (such as blue or informative screen). Alternatively, the FORCE_VIDEO and FORCE_AUDIO bits of the GMSL serializer can be used to mask A/V data input of the GMSL serializer.	—	—
6	Writes 0 to the ENCRYPTION_ENABLE bit of the GMSL serializer and deserializer.	Disables encryption and transmits low-value content A/V data.	Disables decryption and outputs low-value content A/V data.
7	Restarts authentication by writing 1 to the RESET_HDCP bit followed by writing 1 to the START_AUTHENTICATION bit in the GMSL serializer.	—	—

Example Repeater Network—Two μ Cs

The example shown in [Figure 58](#) has one repeater and two μ Cs. [Table 20](#) summarizes the authentication operation.

Detection and Action Upon New Device Connection

When a new device is connected to the system, the device must be authenticated and the device's KSV checked against the revocation list. The downstream μ Cs can set the NEW_DEV_CONN bit of the upstream receiver and invoke an interrupt to notify upstream μ Cs.

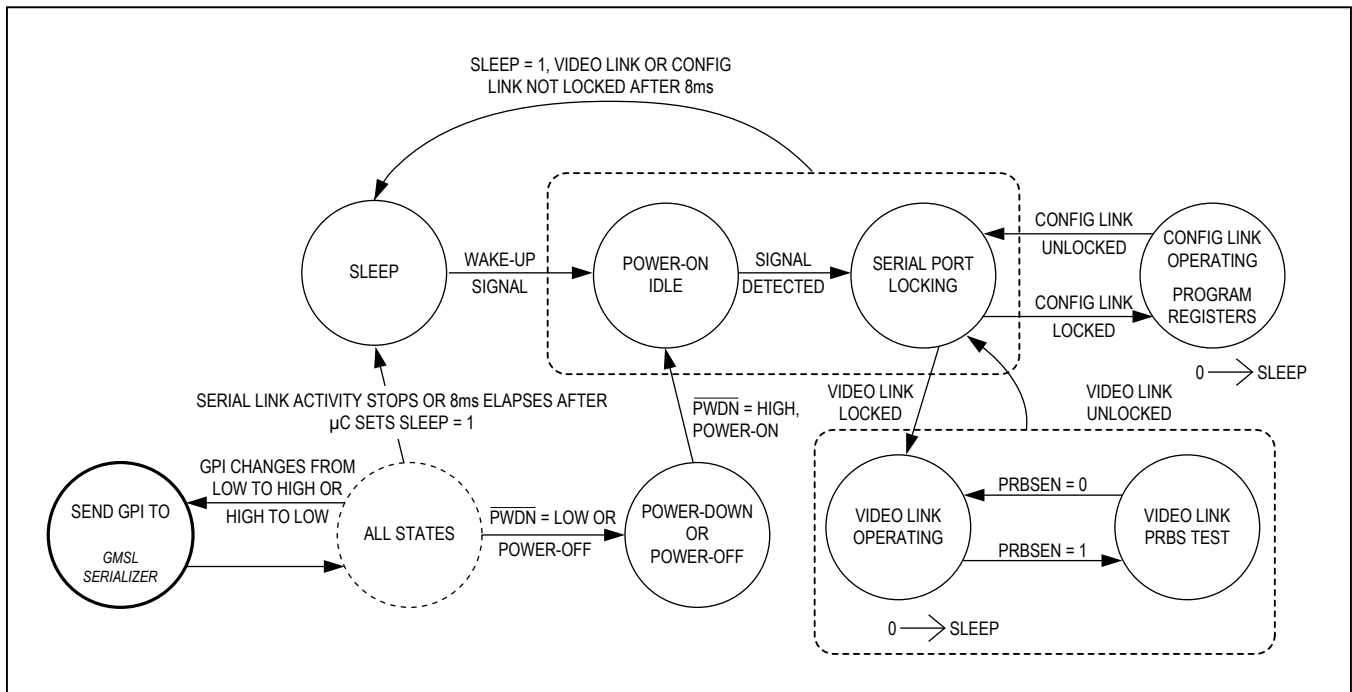

Figure 57. State Diagram (CDS = High)

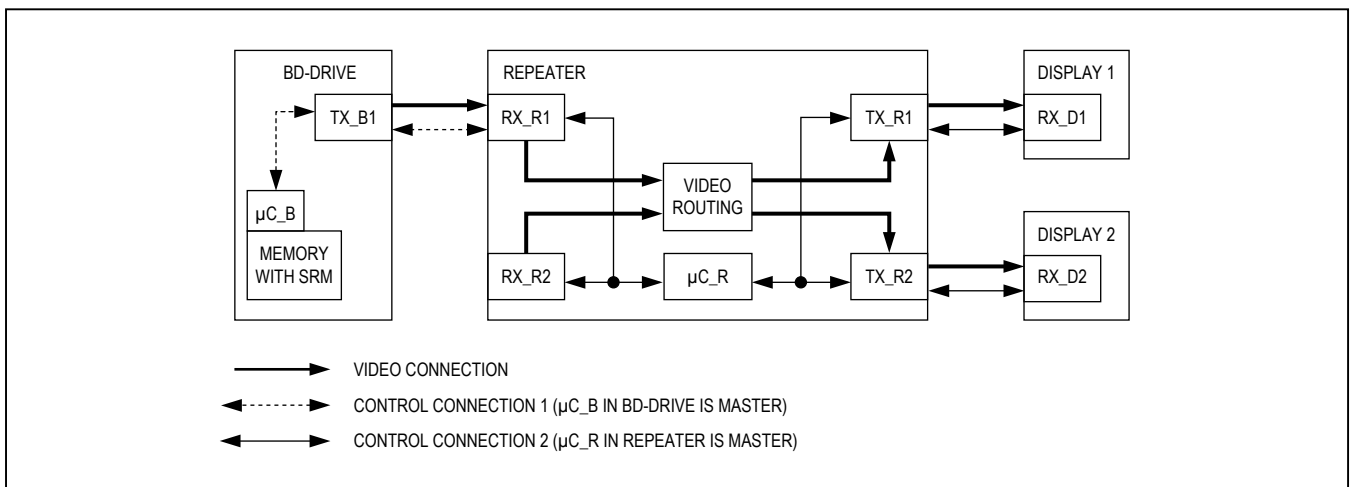

Figure 58. Example Network with One Repeater and Two μ Cs (Tx = GMSL Serializer's, Rx = Deserializer's)

Table 20. HDCP Authentication and Normal Operation (One Repeater, Two μCs)—First and Second Parts of the HDCP Authentication Protocol

NO.	μC_B	μC_R	HDCP GMSL SERIALIZER (TX_B1, TX_R1, TX_R2)	HDCP GMSL DESERIALIZER (RX_R1, RX_D1, RX_D2)
			TX_B1 CDS = 0 TX_R1 CDS = 0 TX_R2 CDS = 0	RX_R1 CDS = 1 RX_D1 CDS = 0 RX_D2 CDS = 0
1	Initial state after power-up.	Initial state after power-up.	All: Power-up waiting for HDCP authentication.	All: Power-up waiting for HDCP authentication.
2	—	Writes REPEATER = 1 in RX_R1. Retries until proper acknowledge frame received. Note: This step must be completed before the first part of authentication is started between TX_B1 and RX_R1 by the μC_B (step 7). For example, to satisfy this requirement, RX_R1 can be held at power-down until μC_R is ready to write the REPEATER bit, or μC_B can poll μC_R before starting authentication.	—	—
3	Makes sure that A/V data not requiring protection (low-value content) is available at the TX_B1 inputs (such as blue or informative screen). Alternatively, the FORCE_VIDEO and FORCE_AUDIO bits of TX_B1 can be used to mask A/V data input of TX_B1. Starts the link between TX_B1 and RX_R1 by writing SEREN = H to TX_B1, or link starts automatically if serializer's AUTOS is low.	—	TX_B1: Starts serialization and transmits low-value content A/V data.	RX_R1: Locks to incoming data stream and outputs low-value content A/V data.
4	—	Starts all downstream links by writing SEREN = H to TX_R1, TX_R2, or links start automatically if AUTOS of transmitters are low.	TX_R1, TX_R2: Starts serialization and transmits low-value content A/V data.	RX_D1, RX_D2: Locks to incoming data stream and outputs low-value content A/V data.

Table 20. HDCP Authentication and Normal Operation (One Repeater, Two μ Cs)—First and Second Parts of the HDCP Authentication Protocol (continued)

NO.	μ C_B	μ C_R	HDCP GMSL SERIALIZER (TX_B1, TX_R1, TX_R2)	HDCP GMSL DESERIALIZER (RX_R1, RX_D1, RX_D2)
			TX_B1 CDS = 0 TX_R1 CDS = 0 TX_R2 CDS = 0	RX_R1 CDS = 1 RX_D1 CDS = 0 RX_D2 CDS = 0
5	Reads the locked bit of RX_R1 and makes sure the link between TX_B1 and RX_R1 is established.	Reads the locked bit of RX_D1 and makes sure the link between TX_R1 and RX_D1 is established. Reads the locked bit of RX_D2 and makes sure the link between TX_R2 and RX_D2 is established.	—	—
6	Optionally, writes a random number seed to TX_B1.	Writes 1 to the GPIO_0_FUNCTION and GPIO_1_FUNCTION bits in RX_R1 to change GPIO functionality used for HDCP purpose. Optionally, writes a random-number seed to TX_R1 and TX_R2.	—	—
7	Starts and completes the first part of the authentication protocol between TX_B1, RX_R1 (see steps 6–10 in Table 17).	—	TX_B1: According to commands from μ C_B, generates AN, computes R0.	RX_R1: According to commands from μ C_B, computes R0'.
8	—	When GPIO_1 = 1 is detected, starts and completes the first part of the authentication protocol between the (TX_R1, RX_D1) and (TX_R2, RX_D2) links (see steps 6–10 in Table 17).	TX_R1, TX_R2: According to commands from μ C_R, generates AN, computes R0.	RX_D1, RX_D2: According to commands from μ C_R, computes R0'.
9	Waits for the VSYNC falling edge and then enables encryption on the (TX_B1, RX_R1) link. Full authentication is not complete yet so it makes sure A/V content that needs protection is not transmitted. Since REPEATER = 1 was read from RX_R1, the second part of authentication is required.	—	TX_B1: Encryption enabled after next VSYNC falling edge.	RX_R1: Decryption enabled after next VSYNC falling edge.

Table 20. HDCP Authentication and Normal Operation (One Repeater, Two μ Cs)—First and Second Parts of the HDCP Authentication Protocol (continued)

NO.	μ C_B	μ C_R	HDCP GMSL SERIALIZER (TX_B1, TX_R1, TX_R2)	HDCP GMSL DESERIALIZER (RX_R1, RX_D1, RX_D2)
			TX_B1 CDS = 0 TX_R1 CDS = 0 TX_R2 CDS = 0	RX_R1 CDS = 1 RX_D1 CDS = 0 RX_D2 CDS = 0
10	—	When GPIO_0 = 1 is detected, enables encryption on the (TX_R1, RX_D1) and (TX_R2, RX_D2) links.	TX_R1, TX_R2: Encryption enabled after next VSYNC falling edge.	RX_D1, RX_D2: Decryption enabled after next VSYNC falling edge.
11		Blocks control channel from μ C_B side by setting REVCCEN = FWDCEN = 0 in RX_R1. Retries until proper acknowledge frame received.	—	RX_R1: Control channel from serializer side (TX_B1) is blocked after FWDCEN = REVCCEN = 0 is written.
12	Waits for some time to allow μ C_R to make the KSV list ready in RX_R1. Then polls (reads) the KSV_LIST_READY bit of RX_R1 regularly until proper acknowledge frame is received and bit is read as 1.	Writes BKSVs of RX_D1 and RX_D2 to the KSV list in RX_R1. Then, calculates and writes the BINFO register of RX_R1.	—	RX_R1: Triggered by μ C_R's write of BINFO, calculates hash value (V') on the KSV list, BINFO and the secret-value M0'.
13		Writes 1 to the KSV_LIST_READY bit of RX_R1 and then unblocks the control channel from the μ C_B side by setting REVCCEN = FWDCEN = 1 in RX_R1.	—	RX_R1: Control channel from the serializer side (TX_B1) is unblocked after FWDCEN = REVCCEN = 1 is written.
14	Reads the KSV list and BINFO from RX_R1 and writes them to TX_B1. If any of the MAX_DEVS_EXCEEDED or MAX_CASCADE_EXCEEDED bits is 1, then authentication fails. Note: BINFO must be written after the KSV list.	—	TX_B1: Triggered by μ C_B's write of BINFO, calculates hash value (V) on the KSV list, BINFO and the secret-value M0.	—
15	Reads V from TX_B1 and V' from RX_R1. If they match, continues with authentication; otherwise, retries up to two more times.	—	—	—
16	Searches for each KSV in the KSV list and BKSv of RX_R1 in the Key Revocation list.	—	—	—

Table 20. HDCP Authentication and Normal Operation (One Repeater, Two μ Cs)—First and Second Parts of the HDCP Authentication Protocol (continued)

NO.	μ C_B	μ C_R	HDCP GMSL SERIALIZER (TX_B1, TX_R1, TX_R2)	HDCP GMSL DESERIALIZER (RX_R1, RX_D1, RX_D2)
			TX_B1 CDS = 0 TX_R1 CDS = 0 TX_R2 CDS = 0	RX_R1 CDS = 1 RX_D1 CDS = 0 RX_D2 CDS = 0
17	If keys are not revoked, the second part of the authentication protocol is completed.	—	—	—
18	Starts transmission of A/V content that needs protection.	—	All: Perform HDCP encryption on high-value A/V data.	All: Perform HDCP decryption on high-value A/V data.

Notification of Start of Authentication and Enable of Encryption to Downstream Links

HDCP repeaters do not immediately begin authentication upon startup or detection of a new device, but instead wait for an authentication request from the upstream transmitter/repeaters.

Use the following procedure to notify downstream links of the start of a new authentication request:

- 1) Host μ C begins authentication with the HDCP repeater's input receiver.
- 2) When AKSV is written to HDCP repeater's input receiver, its AUTH_STARTED bit is automatically set and its GPIO1 goes high (if GPIO1_FUNCTION is set to high).
- 3) HDCP repeater's μ C waits for a low-to-high transition on HDCP repeater input receiver's AUTH_STARTED bit and/or GPIO1 (if configured) and starts authentication downstream.
- 4) HDCP repeater's μ C resets the AUTH_STARTED bit.

Set GPIO0_FUNCTION to high to have GPIO0 follow the ENCRYPTION_ENABLE bit of the receiver. The repeater μ C can use this function for notification when encryption is enabled/disabled by an upstream μ C.

Applications Information

Self PRBS Test

The serializers include a PRBS pattern generator that works with bit-error verification in the deserializer. To run the PRBS test, first disable HDCP encryption. Next, set DISHSFILT, DISVSFILT, and DISDEFILT to 1, to disable glitch filter in the deserializer. Then, set PRBSEN = 1 (0x04, D5) in the serializer and then in the deserializer. To exit the PRBS test, set PRBSEN = 0 (0x04, D5) in the deserializer and then in the serializer.

Error Checking

The deserializers check the serial link for errors and store the number of decoding errors in the 8-bit registers DECERR (0x0D). If a large number of decoding errors are detected within a short duration (error rate $\geq 1/4$), the deserializers lose lock and stop the error counter. The deserializers then attempt to relock to the serial data. DECERR reset upon successful video link lock, successful readout of the register (through μ C), or whenever auto error reset is enabled. The deserializers use a separate PRBS register during the internal PRBS test, and DECERR are reset to 0x00.

$\overline{\text{ERR}}$ Output

The deserializers have an open-drain $\overline{\text{ERR}}$ output. This output asserts low whenever the number of decoding errors exceeds the error thresholds during normal operation, or when at least one PRBS error is detected during PRBS test. $\overline{\text{ERR}}$ reasserts high whenever DECERR resets, due to DECERR readout, video link lock, or auto error reset.

Auto Error Reset

The default method to reset errors is to read the respective error registers in the deserializers (0x0D and 0x0E). Auto error reset clears the error counters DECERR and the $\overline{\text{ERR}}$ output $\sim 1\mu\text{s}$ after $\overline{\text{ERR}}$ goes low. Auto error reset is disabled on power-up. Enable auto error reset through AUTORST (0x06, D5). Auto error reset does not run when the device is in PRBS test mode.

Dual μC Control

Usually systems have one microcontroller to run the control channel, located on the serializer side for display applications or on the deserializer side for image-sensing applications. However, a μC can reside on each side simultaneously and trade off running the control channel. In this case, each μC can communicate with the serializer and deserializer and any peripheral devices.

Contention occurs if both μC s attempt to use the control channel at the same time. It is up to the user to prevent this contention by implementing a higher level protocol. In addition, the control channel does not provide arbitration between I²C masters on both sides of the link. An acknowledge frame is not generated when communication fails due to contention. If communication across the serial link is not required, the μC s can disable the forward and reverse control channel using the FWCCEN and REVCCEN bits (0x04, D[1:0]) in the serializer/deserializer. Communication across the serial link is stopped and contention between μC s cannot occur.

As an example of dual μC use in an image-sensing application, the serializer can be in sleep mode and waiting for wake-up by μC on the deserializer side. After wake-up, the serializer-side μC assumes master control of the serializer's registers.

Changing the Clock Frequency

It is recommended that the serial link be enabled after the video clock (f_{pixel}) and the control-channel clock ($f_{\text{UART}}/f_{\text{I}^2\text{C}}$) are stable. When changing the clock frequency, stop the video clock for $5\mu\text{s}$, apply the clock at the new frequency, then restart the serial link or toggle SEREN. On-the-fly changes in clock frequency are possible if the new frequency is immediately stable and without glitches. The reverse control channel remains unavailable for $500\mu\text{s}$ after serial link start or stop. When using the UART interface, limit on-the-fly changes in f_{UART} to factors of less than 3.5 at a time to ensure that the device recognizes the UART sync pattern. For example, when lowering the UART frequency from 1Mbps to 100kbps, first send data at 333kbps then at 100kbps for reduction ratios of 3 and 3.333, respectively.

Spread-Spectrum Clock Tracking

Using a spread-spectrum clock source can reduce EMI/EMC on the serial and MIPI data. The deserializer can track a spread-spectrum signal from the serializer. Use a spread $< \pm 1\%$ for CSI-2 output rates $\leq 400\text{MHz}$. Use a spread $< \pm 0.5\%$ for CSI-2 output rates $> 400\text{MHz}$.

Fast Detection of Loss-of-Synchronization

A measure of link quality is the recovery time from loss-of-synchronization. The host can be quickly notified of loss-of-lock by connecting the deserializer's LOCK output to the GPI input. If other sources use the GPI input, such as a touch-screen controller, the μC can implement a routine to distinguish between interrupts from loss-of-sync and normal interrupts. Reverse control-channel communication does not require an active forward link to operate and accurately tracks the LOCK status of the GMSL link. LOCK asserts for video link only and not for the configuration link.

Providing a Frame Sync (Camera Applications)

The GPI/GPO provide a simple solution for camera applications that require a frame sync signal from the ECU (e.g., surround-view systems). Connect the ECU frame sync signal to the GPI input, and connect GPO output to the camera frame sync input. GPI/GPO has a typical delay of $275\mu\text{s}$. Skew between multiple GPI/GPO channels is typically $115\mu\text{s}$. If a lower skew signal is required, connect the camera's frame sync input to one of the deserializer's GPIOs and use an I²C broadcast write command to change the GPIO output state. This has a maximum skew of $1.5\mu\text{s}$, independent from the used I²C bit rate.

Software Programming of the Device Addresses

The serializers and deserializers have programmable device addresses. This allows multiple GMSL devices, along with I²C peripherals, to coexist on the same control channel. The serializer device address is in register 0x00 of each device, while the deserializer device address is in register 0x01 of each device. To change a device address, first write to the device whose address changes (register 0x00 of the serializer for serializer device address change, or register 0x01 of the deserializer for deserializer device address change). Then write the same address into the corresponding register on the other device (register 0x00 of the deserializer for serializer device address change, or register 0x01 of the serializer for deserializer device address change).

Three-Level Configuration Inputs

CX/TP and BWS are three-level inputs that control the serial interface configuration and power-up defaults. Connect three-level inputs through a pullup resistor to IOVDD to set a high level, a pulldown resistor to GND to set a low level, or open to set a mid level. For digital control, use three-state logic to drive the three-level logic input.

Configuration Blocking

The deserializers can block changes to registers. Set CFGBLOCK to make registers 0x00 to 0x1F as read only. Once set, the registers remain blocked until the supplies are removed or until PWDN is low.

Compatibility with Other GMSL Devices

The deserializers are designed to pair with the MAX9275–MAX9281 serializers, but interoperate with any GMSL serializers. See [Table 21](#) for operating limitations

Key Memory

Each device has a unique HDCP key set that is stored in secure nonvolatile memory (NVM). The HDCP key set consists of 40 56-bit private keys and one 40-bit public key. The NVM is qualified for automotive applications.

HS/VS/DE Inversion

The deserializers use an active-high HS, VS, and DE for encoding and HDCP encryption. Set INVHSYNC, INVVSYNC, and INVDE in the serializer to invert active-low input signals for use with the GMSL devices. Set INVHSYNC, INVVSYNC, and INVDE in the deserializer (register 0x14) to output active-low signals for use with downstream devices.

WS/SCK Inversion

The deserializers use standard polarities for I²S. Set INVWS and INVSCCK in the serializer (register 0x1B) to invert opposite polarity signals for use with the GMSL devices. Set INVWS and INVSCCK in the deserializer (register 0x1D) to output reverse-polarity signals for downstream use.

GPIOs

The deserializers have two open-drain GPIOs available when not used for HDCP purposes (see the [Notification of Start of Authentication and Enable of Encryption to Downstream Links](#) section), GPIO1OUT and GPIO0OUT (0x06, D3 and D1) set the output state of the GPIOs. Setting the GPIO output bits to 0 low pulls the output low, while setting the bits to 1 leaves the output undriven, and pulled high through internal/external pullup resistors. The GPIO input buffers are always enabled. The input states are stored in GPIO1 and GPIO0 (0x06, D2 and D0). Set GPIO1OUT/GPIO0OUT to 1 when using GPIO1/GPIO0 as an input.

Line-Fault Detection

The line-fault detector monitors for line failures such as short to ground, short to battery, and open link for system-fault diagnosis. Figure 1 shows the required external resistor connections. LFLT = low when a line fault is detected and LFLT goes high when the line returns to normal. The line-fault type is stored in 0x08 D[3:0] of the serializer. Filter LFLT with the μ C to reduce the detector's susceptibility to short ground shifts. The fault-detector threshold voltages are referenced to the serializer ground. Additional passive components set the DC level of the cable. If the serializer and GMSL deserializer grounds are different, the link DC voltage during normal operation can vary and cross one of the fault-detection thresholds.

Table 21. MAX9288/MAX9290 Feature Compatibility

FEATURE	GMSL SERIALIZER
HDCP (MAX9290 only)	If feature not supported in serializer, must not be turned on in the MAX9290.
High-bandwidth mode	If feature not supported in serializer, must only use 24-bit and 32-bit modes.
I ² C-to-I ² C	If feature not supported in serializer, must use UART-to-I ² C or UART-to-UART.
Coax	If feature not supported in serializer, must connect unused serial output through 200nF and 50 Ω in series to V _{DD} and set the reverse control channel amplitude to 100mV.
High-immunity control channel	If feature not supported in serializer, must use the legacy reverse control-channel mode.
TDM encoding	If feature not supported in serializer, must use I ² S encoding (with 50% WS duty cycle), if supported.
I ² S encoding	If feature not supported in serializer, must disable I ² S in the MAX9288/MAX9290.

For the fault-detection circuit, select the resistor's power rating to handle a short to the battery. In coax mode, leave the unused line-fault inputs unconnected. To detect the short-together case, refer to Application Note 4709: *GMSL Line-Fault Detection*. [Table 23](#) lists the mapping for line fault types

Internal Input Pulldowns

The control and configuration inputs (except three-level inputs) include a pulldown resistor to GND. External pulldown resistors are not needed.

Choosing I²C/UART Pullup Resistors

I²C and UART open-drain lines require a pullup resistor to provide a logic-high level. There are tradeoffs between power dissipation and speed, and a compromise may be required when choosing pullup resistor values. Every device connected to the bus introduces some capacitance even when the device is not in operation. I²C specifies 300ns rise times (30% to 70%) for fast mode, which is defined for data rates up to 400kbps (see the I²C specifications in the [AC Electrical Characteristics](#) table for details). To meet the fast-mode rise-time requirement, choose the pullup resistors so that rise time $t_R = 0.85 \times R_{PULLUP} \times C_{BUS} < 300\text{ns}$. The waveforms are not recognized if the transition time becomes too slow. The device supports I²C/UART rates up to 1Mbps.

AC-Coupling

AC-coupling isolates the receiver from DC voltages up to the voltage rating of the capacitor. Capacitors at the serializer output and at the deserializer input are needed for proper link operation and to provide protection if either end of the cable is shorted to a battery. AC-coupling blocks low-frequency ground shifts and low-frequency common-mode noise.

Selection of AC-Coupling Capacitors

Voltage droop and the digital sum variation (DSV) of transmitted symbols cause signal transitions to start from different voltage levels. Because the transition time is fixed, starting the signal transition from different voltage levels causes timing jitter. The time constant for an AC-coupled link needs to be chosen to reduce droop and jitter to an acceptable level. The RC network for an AC-coupled link consists of the CML/coax receiver termination resistor (R_{TR}), the CML/coax driver termination resistor (R_{TD}), and the series AC-coupling capacitors (C). The RC time constant for four equal-value series capacitors is $(C \times (R_{TD} + R_{TR}))/4$. R_{TD} and R_{TR} are required to match the transmission line impedance (usually 100Ω

differential, 50Ω single ended). This leaves the capacitor selection to change the system time constant. Use at 0.22μF (using legacy reverse control channel), 47nF (using high-immunity reverse control channel), or larger high-frequency surface-mount ceramic capacitors, with sufficient voltage rating to withstand a short to battery, to pass the lower speed reverse control-channel signal. Use capacitors with a case size less than 3.2mm x 1.6mm to have lower parasitic effects to the high-speed signal.

Power-Supply Circuits and Bypassing

The deserializers use an AVDD18 and DVDD18 of 1.7V to 1.9V and an AVDD3 of 3.0V to 3.6V. All single-ended inputs and outputs except for the serial input derive power from an IOVDD of 1.7V to 3.6V that scale with IOVDD. Proper voltage-supply bypassing is essential for high-frequency circuit stability.

Power-Supply Table

Power-supply currents shown in the [DC Electrical Characteristics](#) table is measured at $V_{IOVDD} = 3.6\text{V}$. If using a different IOVDD voltage, the IOVDD worst-case supply current will vary. HDCP operation (MAX9290 only) draws additional current. This is shown in [Table 24](#).

Cables and Connectors

Interconnect for CML typically has a differential impedance of 100Ω. Use cables and connectors that have matched differential impedance to minimize impedance discontinuities. Coax cables typically have a characteristic impedance of 50Ω, contact the factory for 75Ω operation). [Table 24](#) lists the suggested cables and connectors used in the GMSL link.

Board Layout

Separate LVCMOS logic signals and CML/coax high-speed signals to prevent crosstalk. Use a four-layer PCB with separate layers for power, ground, CML/coax, and LVCMOS logic signals. Layout PCB traces close to each other for a 100Ω differential characteristic impedance for STP. The trace dimensions depend on the type of trace used (microstrip or stripline). Note that two 50Ω PCB traces do not have 100Ω differential impedance when brought close together—the impedance goes down when the traces are brought closer. Use a 50Ω trace for the single-ended output when driving coax.

Route the PCB traces for differential CML channel in parallel to maintain the differential characteristic impedance. Avoid vias. Keep PCB traces that make up a differential pair equal length to avoid skew within the differential pair.

Table 22. Line-Fault Mapping

REGISTER ADDRESS	BITS	NAME	VALUE	LINE-FAULT TYPE
0x76	D[3:2]	LFNEG	00	Negative cable wire shorted to supply voltage
			01	Negative cable wire shorted to ground
			10	Normal operation
			11	Negative cable wire disconnected
	D[1:0]	LFPOS	00	Positive cable wire shorted to supply voltage
			01	Positive cable wire shorted to ground
			10	Normal operation
			11	Positive cable wire disconnected

Table 23. Additional Supply Current from HDCP (MAX9290 Only)

PIXEL CLOCK (MHz)	MAXIMUM HDCP CURRENT (mA)
16.6	6
33.3	9
36.6	9
66.6	12
104	18

Table 24. Suggested Connectors and Cables for GMSL

VENDOR	CONNECTOR	CABLE	TYPE
Rosenberger	59S2AX-400A5-Y	Dacar 302	Coax
Rosenberger	D4S10A-40ML5-Z	Dacar 535-2	STP
Nissei	GT11L-2S	F-2WME AWG28	STP
JAE	MX38-FF	A-BW-Lxxxxx	STP

ESD Protection

ESD tolerance is rated for Human Body Model, IEC 61000-4-2, and ISO 10605. The ISO 10605 and IEC 61000-4-2 standards specify ESD tolerance for electronic systems. The serial link inputs are rated for ISO 10605 ESD protection and IEC 61000-4-2 ESD protection. All pins are tested for the Human Body Model. The Human Body Model discharge components are $C_S = 100\text{pF}$ and $R_D = 1.5\text{k}\Omega$ (Figure 59). The IEC 61000-4-2 discharge components are $C_S = 150\text{pF}$ and $R_D = 330\Omega$ (Figure 60). The ISO 10605 discharge components are $C_S = 330\text{pF}$ and $R_D = 2\text{k}\Omega$ (Figure 61).

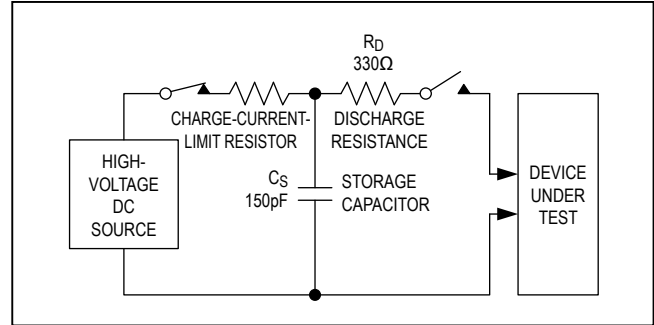

Figure 60. IEC 61000-4-2 Contact Discharge ESD Test Circuit

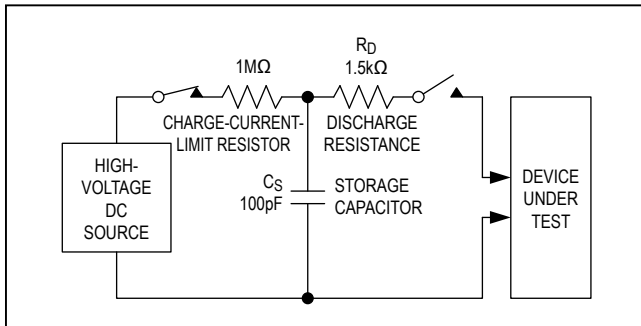

Figure 59. Human Body Model ESD Test Circuit

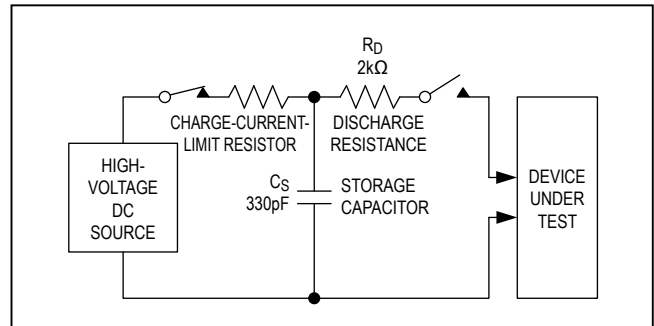

Figure 61. ISO 10605 Contact Discharge ESD Test Circuit

Table 25. Register Table

REGISTER ADDRESS	BITS	NAME	VALUE	FUNCTION	DEFAULT VALUE
0x00	D[7:1]	SERID	XXXXXXX	Serializer device address (power-up default value depends on latched address pin level).	XX00XX0
	D0	—	0	Reserved	0
0x01	D[7:1]	DESID	XXXXXXX	Deserializer device address (power-up default value depends on latched address pin level).	XX01XXX
	D0	CFGBLOCK	0 1	Normal operation Registers 0x00 to 0x1F and 0x60 to 0x67 are read only.	0
0x02	D[7:6]	—	00	Reserved	00
	D5	AUDIOMODE	0	WS, SCK configured as output (deserializer-sourced clock).	0
			1	WS, SCK configured as input (system-sourced clock).	
	D4	AUDIOEN	0	Disable I ² S/TDM channel.	1
			1	Enable I ² S/TDM channel.	
D[3:0]	—	1111	Reserved	1111	
0x03	D[7:0]	—	00000000	Reserved	00000000
0x04	D7	LOCKED	0	LOCK output is low.	0 (Read only)
			1	LOCK output is high.	
	D6	—	0	Reserved	0
	D5	PRBSEN	0	Disable PRBS test.	0
			1	Enable PRBS test.	
	D4	SLEEP	0	Normal mode (power-up default value depends on CDS and MS pin value at power-up).	0, 1
			1	Activate sleep mode (power-up default value depends on CDS and MS pin value at power-up).	
	D[3:2]	INTTYPE	00	Local control channel uses I ² C when I2CSEL = 0.	01
			01	Local control channel uses UART when I2CSEL = 0.	
			10, 11	Local control channel disabled.	
	D1	REVCCEN	0	Disable reverse control channel to serializer (sending).	1
			1	Enable reverse control channel to serializer (sending).	
D0	FWDCEN	0	Disable forward control channel from serializer (receiving)	1	
		1	Enable forward control channel from serializer (receiving).		

Table 25. Register Table (continued)

REGISTER ADDRESS	BITS	NAME	VALUE	FUNCTION	DEFAULT VALUE
0x05	D7	I2CMETHOD	0	I ² C conversion sends the register address when converting UART-to-I ² C.	0
			1	Disable sending of I ² C register address when converting UART-to-I ² C (command-byte-only mode).	
	D[6:5]	HPFTUNE	00	7.5MHz equalizer highpass filter cutoff frequency.	01
			01	3.75MHz equalizer highpass filter cutoff frequency.	
			10	2.5MHz equalizer highpass filter cutoff frequency.	
			11	1.87MHz equalizer highpass filter cutoff frequency.	
	D4	PDEQ	0	Enable equalizer.	0
			1	Disable equalizer.	
	D[3:0]	EQTUNE	0000	2.1dB equalizer-boost gain.	0100,1001
			0001	2.8dB equalizer-boost gain.	
			0010	3.4dB equalizer-boost gain.	
			0011	4.2dB equalizer-boost gain.	
			0100	5.2dB equalizer-boost gain. Power-up default when EQS is high.	
			0101	6.2dB equalizer-boost gain.	
			0110	7dB equalizer-boost gain.	
			0111	8.2dB equalizer-boost gain.	
1000			9.4dB equalizer-boost gain.		
1001			10.7dB equalizer-boost gain. Power-up default when EQS is low.		
1010			11.7dB equalizer-boost gain.		
1011			13dB equalizer-boost gain.		
11XX	Do not use.				

Table 25. Register Table (continued)

REGISTER ADDRESS	BITS	NAME	VALUE	FUNCTION	DEFAULT VALUE
0x06	D7	PRBSTYPE	0	Device uses standard PRBS test.	0
			1	Device uses MAX9271/MAX9273-compatible PRBS test (for use with the MAX9271/MAX9273 only).	
	D6	AUTORST	0	Do not automatically reset error registers and outputs.	0
			1	Automatically reset DECERR register 1 μ s after ERR asserts.	
	D5	DISGPI	0	Enable GPI-to-GPO signal transmission to serializer.	0
			1	Disable GPI-to-GPO signal transmission to serializer.	
	D4	GPIIN	0	GPI input is low.	0 (Read only)
			1	GPI input is high.	
	D3	GPIO1OUT	0	Set GPIO1 to low.	1
			1	Set GPIO1 to high.	
	D2	GPIO1IN	0	GPIO1 input is low.	0 (Read only)
			1	GPIO1 input is high.	
	D1	GPIO0OUT	0	Set GPIO0 to low.	1
			1	Set GPIO0 to high.	
D0	GPIO0IN	0	GPIO0 input is low.	0 (Read only)	
		1	GPIO0 input is high.		
0x07	D[7:0]	—	01010100	Reserved	01010100

Table 25. Register Table (continued)

REGISTER ADDRESS	BITS	NAME	VALUE	FUNCTION	DEFAULT VALUE
0x08	D[7:5]	—	001	Reserved	001
	D[4:3]	HVSRC	00	D18/D19 assigned to HS/VS .	00
			01	D14/D15 assigned to HS/VS (for use with the MAX9271).	
			1X	D0/D1 assigned to HS/VS (D[19:2] shifted to D[17:0]). For use with the MAX9271/MAX9273 with H/V inversion).	
	D2	DISDEFILT	0	Enable DE glitch filter. Power-up default when BWS = high or low.	X
			1	Disable DE glitch filter. Power-up default when BWS = open.	
	D1	DISVSFILT	0	Enable VS glitch filter. Power-up default when BWS = high or low.	X
			1	Disable VS glitch filter. Power-up default when BWS = open.	
	D0	DISHSFILT	0	Enable HS glitch filter. Power-up default when BWS = high or low.	X
			1	Disable HS glitch filter. Power-up default when BWS = open.	
0x09	D7	VSYNCOUT	0	Normal CNTL3 operation.	0
			1	CNTL3 outputs VSYNC.	
	D6	AUTOPPL	0	Automatic pixel count disabled.	0
			1	Automatic pixel count enabled.	
D[5:0]	—	000000	Reserved	000000	
0x0A	D[7:0]	—	00010XXX	Reserved	00010XXX
0x0B	D[7:0]	—	00100000	Reserved	00100000
0x0C	D[7:0]	ERRTHR	XXXXXXXX	Error threshold for decoding errors.	00000000
0x0D	D[7:0]	DECERR	XXXXXXXX	Decoding error counter.	00000000 (Read only)
0x0E	D[7:0]	PRBSERR	XXXXXXXX	PRBS error counter.	00000000 (Read only)
0x0F	D[7:0]	—	XXXXXXXX	Reserved	(Read only)
0x10	D[7:0]	—	XXXXXXXX	Reserved	(Read only)
0x11	D7	REVFAST	0	High-immunity reverse channel mode uses 500kbps bit rate.	0
			1	High-immunity reverse channel mode uses 1Mbps bit rate.	
	D[6:0]	—	0100010	Reserved	0100010

Table 25. Register Table (continued)

REGISTER ADDRESS	BITS	NAME	VALUE	FUNCTION	DEFAULT VALUE	
0x12	D7	MCLKSRC	0	MCLK derived from PCLKOUT. See Table 9.	0	
			1	MCLK derived from internal oscillator.		
	D[6:0]	MCLKDIV	0000000	MCLK disabled.	0000000	
			XXXXXXXX	MCLK divider.		
0x13	D[7:0]	—	0X000000	Reserved	0X000000	
0x14	D7	INVVS	0	Normal VSYNC operation.	0	
			1	Invert VSYNC.		
	D6	INVHS	0	Normal HSYNC operation.	0	
			1	Invert HSYNC.		
	D5	INVDE	0	Normal DE operation.	0	
			1	Invert DE.		
	D4	DRS	0	High data rate mode. Power-up default when DRS pin is low (transitions on the DRS pin override the DRS bit setting).	0, 1	
			1	Low data rate mode. Power-up default when DRS pin is high (transitions on the DRS pin override the DRS bit setting).		
	D3	DCS	0	Normal parallel output driver current.	0	
			1	Boosted parallel output driver current.		
	D2	DISRWAKE	0	Enable remote wake-up.	0	
			1	Disable remote wake-up.		
	D1	—	—	0	Reserved	0
	D0	INTOUT	0	Drive INTOUT low.	0	
			1	Drive INTOUT high.		

Table 25. Register Table (continued)

REGISTER ADDRESS	BITS	NAME	VALUE	FUNCTION	DEFAULT VALUE
0x15	D7	AUTOINT	0	INTOUT pin output controlled by INTOUT bit above.	1
			1	Writes to any AVINFO bytes sets INTOUT to high. Reads to any AVINFO bytes sets INTOUT to low.	
	D6	HVTREN	0	Disable HS/VS tracking (power-up default value depends on state of BWS input value at power-up).	0, 1
			1	Enable HS/VS tracking (power-up default value depends on state of BWS input value at power-up).	
	D5	DETREN	0	Disable DE tracking (power-up default value depends on state of BWS input value at power-up).	0, 1
			1	Enable DE tracking (power-up default value depends on state of BWS input value at power-up).	
	D4	HVTRMODE	0	Partial periodic HS/VS and DE tracking.	1
			1	Partial and full periodic HS/VS and DE tracking.	
	D[3:2]	—	00	Reserved	00
	D1	MCLKWS	0	MCLK output operates normally.	0
1			WS is output from MCLK (MCLK mirrors WS).		
D0	MCLKPIN	0	MCLK output on DOUT28/CNTL2.	0	
		1	MCLK output on ADD0/CNTL0.		
0x16	D7	HIGHIMM	0	Legacy reverse control channel mode (power-up default value depends on HIM/CNTL1 at power-up).	0, 1
			1	High-immunity reverse control channel mode (power-up default value depends on HIM/CNTL1 at power-up).	
	D[6:0]	—	1011010	Reserved	1011010
0x17	D[7:0]	—	000XXXXX	Reserved	000XXXXX
0x18	D[7:1]	I2CSRCA	XXXXXXX	I ² C address translator source A.	0000000
	D0	—	0	Reserved	0
0x19	D[7:1]	I2CDSTA	XXXXXXX	I ² C address translator destination A.	0000000
	D0	—	0	Reserved	0
0x1A	D[7:1]	I2CSRCA	XXXXXXX	I ² C address translator source B.	0000000
	D0	—	0	Reserved	0
0x1B	D[7:1]	I2CDSTB	XXXXXXX	I ² C address translator destination B.	0000000
	D0	—	0	Reserved	0

Table 25. Register Table (continued)

REGISTER ADDRESS	BITS	NAME	VALUE	FUNCTION	DEFAULT VALUE
0x1C	D7	I2CLOCACK	0	Acknowledge not generated when forward channel is not available.	1
			1	I ² C to I ² C-slave generates local acknowledge when forward channel is not available.	
	D[6:5]	I2CSLVSH	00	352ns/117ns I ² C setup/hold time.	01
			01	469ns/234ns I ² C setup/hold time.	
			10	938ns/352ns I ² C setup/hold time.	
			11	1046ns/469ns I ² C setup/hold time.	
	D[4:2]	I2CMSTBT	000	8.47kbps (typ) I ² C to I ² C-master bit-rate setting.	101
			001	28.3kbps (typ) I ² C to I ² C-master bit-rate setting.	
			010	84.7kbps (typ) I ² C to I ² C-master bit-rate setting.	
			011	105kbps (typ) I ² C to I ² C-master bit-rate setting.	
			100	173kbps (typ) I ² C to I ² C-master bit-rate setting.	
			101	339kbps (typ) I ² C to I ² C-master bit-rate setting.	
			110	533kbps (typ) I ² C to I ² C-master bit-rate setting.	
			111	837kbps (typ) I ² C to I ² C-master bit-rate setting.	
D[1:0]	I2CSLVTO	00	64μs (typ) I ² C to I ² C-slave remote timeout.	10	
		01	256μs (typ) I ² C to I ² C-slave remote timeout.		
		10	1024μs (typ) I ² C to I ² C-slave remote timeout.		
		11	No I ² C to I ² C-slave remote timeout.		
0x1D	D[7:3]	—	00000	Reserved	00000
	D2	AUDUFBEH	0	Audio FIFO repeats last audio word when FIFO is empty.	0
			1	Audio FIFO outputs all zeroes when FIFO is empty.	
	D1	INVSK	0	Do not invert SCK at output.	0
			1	Invert SCK at output.	
	D0	INVWS	0	Do not invert WS at output.	0
1			Invert WS at output.		
0x1E	D[7:0]	ID	00101XX0	Device identifier (MAX9288 = 0x2A) (MAX9290 = 0x2C)	00101XX0 (Read only)

Table 25. Register Table (continued)

REGISTER ADDRESS	BITS	NAME	VALUE	FUNCTION	DEFAULT VALUE
0x1F	D[7:5]	—	000	Reserved	000 (Read only)
	D4	CAPS	0	Not HDCP capable (MAX9288).	(Read only)
			1	HDCP capable (MAX9290).	
	D[3:0]	REVISION	XXXX	Device revision.	(Read only)
0x40 to 0x59	D[7:0]	AVINFO	XXXXXXXX	Video/audio format/status/information bytes.	All zeroes
0x60	D[7:6]	VC	00	CSI-2 outputs with ID as virtual channel 0.	00
			01	CSI-2 outputs with ID as virtual channel 1.	
			10	CSI-2 outputs with ID as virtual channel 2.	
			11	CSI-2 outputs with ID as virtual channel 3.	
	D5	INPUTBW	0	RAW8/10/12 mode uses single load. YUV422-8b/10b uses muxed mode.	0
			1	RAW8/10/12 mode uses double load. YUV422-8b/10b uses normal mode.	
	D4	OLDI	0	RGB888 uses VESA format (MSB to LSB bit order = 7, 6, 5, 4, 3, 2, 1, 0).	1
			1	RGB888 uses oLDI format (MSB to LSB bit order = 5, 4, 3, 2, 1, 0, 7, 6).	
	D[3:0]	DATATYPE	0000	CSI-2 output uses RGB888 (Power-on default).	0000
			0001	CSI-2 output uses RGB565.	
			0010	CSI-2 output uses RGB666.	
			0011	CSI-2 output uses YUV 422 8-bit.	
			0100	CSI-2 output uses YUV 422 10-bit.	
			0101	CSI-2 output uses RAW8.	
			0110	CSI-2 output uses RAW10.	
0111			CSI-2 output uses RAW12.		
1000			CSI-2 output uses RAW14.		
1001			CSI-2 output uses user defined generic 24-bit (0x30).		
1010			CSI-2 output uses user defined YUV422 12-bit (0x30).		
1011	CSI-2 output uses user defined generic 8-bit (0x31).				
11XX	Do not use.				
0x61	D[7:0]	PIXELCNTLOW	XXXXXXXX	Low byte of pixel count. Set this register according to the pixel count per line.	00000000
0x62	D[7:0]	PIXELCNTHIGH	XXXXXXXX	High byte of pixel count. Set this register according to the pixel count per line.	00000000

Table 25. Register Table (continued)

REGISTER ADDRESS	BITS	NAME	VALUE	FUNCTION	DEFAULT VALUE
0x63	D[7:6]	TCLKPREPARE	00	Drive clock lane LP00 for 64ns before starting HS transmission	00
			01	Drive clock lane LP00 for 72ns before starting HS transmission.	
			10	Drive clock lane LP00 for 80ns before starting HS transmission.	
			11	Drive clock lane LP00 for 88ns before starting HS transmission.	
	D[5:4]	TCLKZERO	00	Drive HS0 state for 360ns + 16-24UI before starting the clock.	00
			01	Drive HS0 state for 720ns + 16-24UI before starting the clock.	
			10	Drive HS0 state for 1.08 μ s + 16-24UI before starting the clock.	
			11	Drive HS0 state for 1.44 μ s + 16-24UI before starting the clock.	
	D[3:0]	—	0000	Reserved	0000

Table 25. Register Table (continued)

REGISTER ADDRESS	BITS	NAME	VALUE	FUNCTION	DEFAULT VALUE
0x64	D[7:6]	THSPREPARE	00	Drive data lane LP00 for 64ns +4UI before starting HS transmission.	00
			01	Drive data lane LP00 for 72ns + 4UI before starting HS transmission.	
			1X	Drive data lane LP00 for 80ns + 4UI before starting HS transmission.	
	D[5:4]	THSZERO	00	Drive HS0 state for 160ns + 24 - 32UI before transmitting the sync sequence.	00
			01	Drive HS0 state for 176ns + 24 - 32UI before transmitting the sync sequence.	
			10	Drive HS0 state for 200ns + 24 - 32UI before transmitting the sync sequence.	
			11	Drive HS0 state for 240ns + 24 - 32UI before transmitting the sync sequence.	
	D[3:2]	THSTRAIL	00	Drive HSTRAIL state for 64ns + 8UI after the last payload data bit of a HS transmission burst.	00
			01	Drive HSTRAIL state for 80ns + 8UI after the last payload data bit of a HS transmission burst.	
			10	Drive HSTRAIL state for 96ns + 8UI after the last payload data bit of a HS transmission burst.	
			11	Drive HSTRAIL state for 120ns + 8UI after the last payload data bit of a HS transmission burst.	
	D[1:0]	TLPX	00	64ns LPTX period length.	00
			01	128ns LPTX period length.	
10			192ns LPTX period length.		
11			256ns LPTX period length.		
0x65	D7	—	0	Reserved	0
	D6	DESEL	0	Normal DE operation.	0
			1	HS input is the DE source.	
	D[5:4]	DATALANEN	00	Data lane D0 enabled.	01
			01	Data lanes D0, D1 enabled.	
			10	Data lanes D0–D2 enabled.	
			11	Data lanes D0–D3 enabled.	
D[3:0]	—	0111	Reserved	0111	

Table 25. Register Table (continued)

REGISTER ADDRESS	BITS	NAME	VALUE	FUNCTION	DEFAULT VALUE
0x66	D[7:6]	D3LANEMAP	00	Data-byte 3 maps to lane 0 (data mapping should be exclusive).	11
			01	Data-byte 3 maps to lane 1.	
			10	Data-byte 3 maps to lane 2.	
			11	Data-byte 3 maps to lane 3.	
	D[5:4]	D2LANEMAP	00	Data byte 2 maps to lane 0 (data mapping should be exclusive).	10
			01	Data byte 2 maps to lane 1.	
			10	Data byte 2 maps to lane 2.	
			11	Data byte 2 maps to lane 3.	
	D[3:2]	D1LANEMAP	00	Data byte 1 maps to lane 0 (data mapping should be exclusive).	01
			01	Data byte 1 maps to lane 1.	
			10	Data byte 1 maps to lane 2.	
			11	Data byte 1 maps to lane 3.	
	D[1:0]	D0LANEMAP	00	Data byte 0 maps to lane 0 (data mapping should be exclusive).	00
			01	Data byte 0 maps to lane 1.	
			10	Data byte 0 maps to lane 2.	
			11	Data byte 0 maps to lane 3.	
0x67	D[7:0]	—	00000000	Reserved	00000000
0x68	D[7:0]	—	11001000	Reserved	11001000
0x69	D[7:0]	—	00000000	Reserved	00000000
0x6A	D[7:0]	—	00000000	Reserved	00000000
0x72	D[7:0]	—	XXXXXXXX	Reserved	XXXXXXXX (Read only)
0x73	D[7:0]	—	XXXXXXXX	Reserved	XXXXXXXX (Read only)
0x74	D[7:0]	—	XXXXXXXX	Reserved	XXXXXXXX (Read only)
0x75	D[7:0]	—	XXXXXXXX	Reserved	XXXXXXXX (Read only)
0x76	D[7:4]	—	0000	Reserved	0000 (Read only)
	D[3:2]	LFNEG	00	Negative cable wire shorted to supply voltage.	00 (Read only)
			01	Negative cable wire shorted to ground.	
			10	Normal operation.	
			11	Negative cable wire disconnected.	
	D[1:0]	LFPOS	00	Positive cable wire shorted to supply voltage.	00 (Read only)
			01	Positive cable wire shorted to ground.	
			10	Normal operation.	
11			Positive cable wire disconnected.		

Table 25. Register Table (continued)

REGISTER ADDRESS	BITS	NAME	VALUE	FUNCTION	DEFAULT VALUE
0x77	D[7:0]	—	XXXXXXXX		(Read only)
0x78	D[7:0]	AUDOUPER	XXXXXXXX	Audio FIFO last overflow/underflow period (AUDIOMODE = 1 only).	(Read only)
0x79	D7	AUDOU	0	Audio FIFO is in underflow (AUDIOMODE = 1 only).	(Read only)
	D[6:5]	—	00	Reserved	00 (Read only)
	D4	APPLERR	0	No pixels-per-line error.	0 (Read only)
			1	Pixels-per-line error detected. Read to clear.	
	D3	PRBSOK	0	MAX9271/MAX9273-compatible PRBS test not completed (or completed without success).	0 (Read only)
			1	MAX9271/MAX9273-compatible PRBS test completed with success.	
	D2	DLOCKED	0	DE tracking not locked.	0 (Read only)
			1	DE tracking locked.	
	D1	VLOCKED	0	VS tracking not locked.	0 (Read only)
			1	VS tracking locked.	
D0	HLOCKED	0	HS tracking not locked.	0 (Read only)	
		1	HS tracking locked.		
0x7B	D[7:0]	LUTADDR	XXXXXXXX	LUT start address for write and read.	00000000
0x7C	D[7:4]	—	0000	Reserved	0000
	D3	LUTPROG	0	Disable LUT write and read.	0
			1	Enable LUT write and read.	
	D2	BLULUTEN	0	Disable blue LUT.	0
			1	Enable blue LUT.	
	D1	GRNLUTEN	0	Disable green LUT.	0
			1	Enable green LUT.	
	D0	REDLUTEN	0	Disable red LUT.	0
			1	Enable red LUT.	
	0x7D	D[7:0]	REDLUT	XXXXXXXX	Red LUT value (see Table 13).
0x7E	D[7:0]	GREENLUT	XXXXXXXX	Green LUT value (see Table 13).	00000000
0x7F	D[7:0]	BLUELUT	XXXXXXXX	Blue LUT value (see Table 13).	00000000

Table 26. HDCP Register Table (MAX9290 Only)

REGISTER ADDRESS	SIZE (BYTES)	NAME	READ/ WRITE	FUNCTION	DEFAULT VALUE (hex)
0X80 to 0x84	5	BKSV	Read only	HDCP receiver KSV.	(Read only)
0X85 to 0x86	2	RI'	Read only	Link verification response.	(Read only)
0X87	1	PJ'	Read only	Enhanced link verification response.	(Read only)
0X88 to 0x8F	8	AN	Read/write	Session random number.	0x0000000000000000
0X90 to 0x94	5	AKSV	Read/write	HDCP transmitter KSV.	0x0000000000
0x95	1	BCTRL	Read/write	D7 = PD_HDCP 1 = Power down HDCP circuits 0 = HDCP circuits normal	0x00
				D[6:4] = Reserved	
				D3 = GPIO1_FUNCTION 1 = GPIO1 mirrors AUTH_STARTED 0 = Normal GPIO1 operation	
				D2 = GPIO0_FUNCTION 1 = GPIO0 mirrors ENCRYPTION_ENABLE 0 = Normal GPIO0 operation	
				D1 = AUTH_STARTED 1 = Authentication started (triggered by write to AKSV) 0 = Authentication not started	
D0 = ENCRYPTION_ENABLE 1 = Enable encryption 0 = Disable encryption					
0x96	1	BSTATUS	Read/write	D[7:2] = Reserved	0x00
				D1 = NEW_DEV_CONN 1 = Set to 1 if a new connected device is detected. 0 = Set to 0 if no new device is connected.	
				D0 = KSV_LIST_READY 1 = Set to 1 if KSV list and BINFO is ready 0 = Set to 0 if KSV list or BINFO is not ready.	

Table 26. HDCP Register Table (MAX9290 Only)

REGISTER ADDRESS	SIZE (BYTES)	NAME	READ/WRITE	FUNCTION	DEFAULT VALUE (hex)
0x97	1	BCAPS	Read/write	D[7:1] = Reserved D0 = REPEATER 1 = Set to one if device is a repeater. 0 = Set to zero if device is not a repeater.	0x00
0x98 to 0x9F	8	—	Read only	Reserved	0x0000000000000000 (Read only)
0xA0 to 0xA3	4	V.H0	Read/write	H0 part of SHA-1 hash value	0x00000000
0xA4 to 0xA7	4	V.H1	Read/write	H1 part of SHA-1 hash value	0x00000000
0xA8 to 0xAB	4	V.H2	Read/write	H2 part of SHA-1 hash value	0x00000000
0xAC to 0xAF	4	V.H3	Read/write	H3 part of SHA-1 hash value	0x00000000
0xB0 to 0xB3	4	V.H4	Read/write	H4 part of SHA-1 hash value	0x00000000
0xB4 to 0xB5	2	BINFO	Read/write	D[15:12] = Reserved D11 = MAX_CASCADE_EXCEEDED 1 = Set to 1 if more than seven cascaded devices attached. 0 = Set to 0 if seven or fewer cascaded devices attached. D[10:8] = DEPTH Depth of cascaded devices D7 = MAX_DEVS_EXCEEDED 1 = Set to one if more than 14 devices attached 0 = Set to zero if 14 or fewer devices attached D[6:0] = DEVICE_COUNT Number of devices attached	0x0000
0xB6	1	GPMEM	Read/write	General-purpose memory byte.	0x00
0xB7 to 0xB9	3	—	Read only	Reserved	0x000000
0xBA to 0xFF	70	KSV_LIST	Read/write	List of KSVs downstream repeaters and receivers (maximum of 14 devices).	All zero

Typical Application Circuit

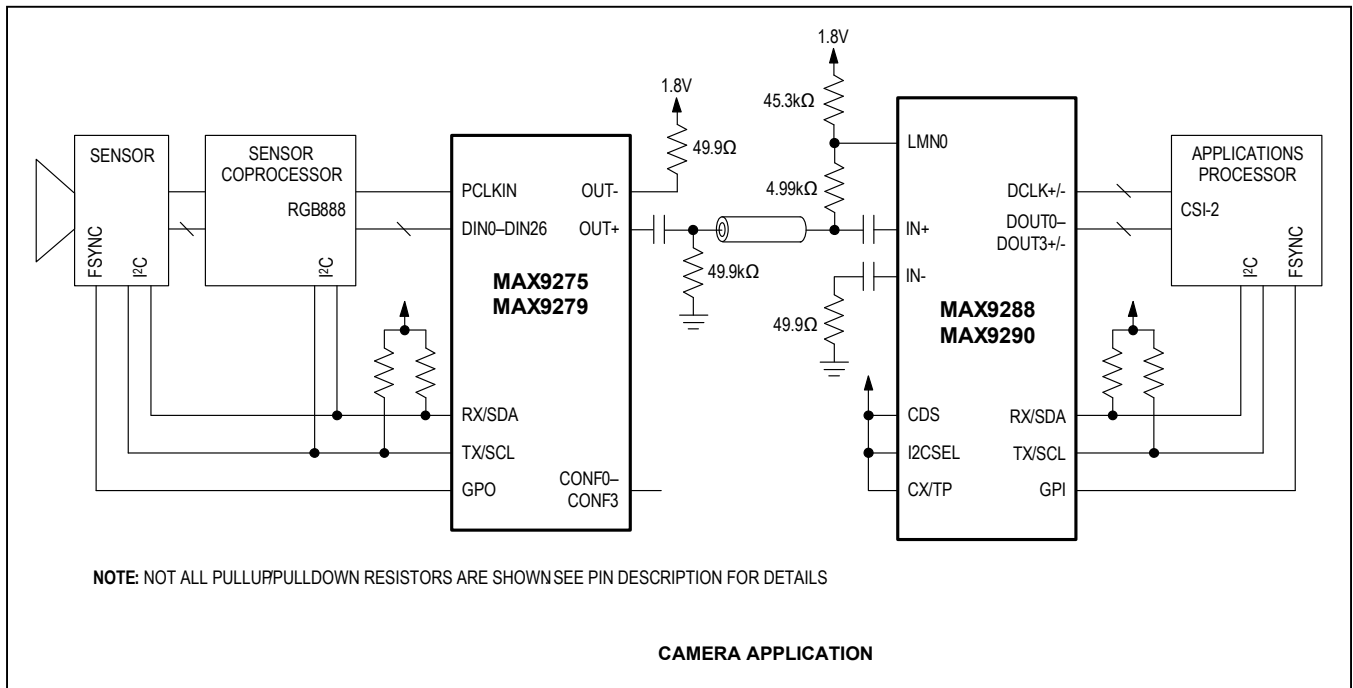

Ordering Information

PART	TEMP RANGE	PIN-PACKAGE	HDCP
MAX9288GGM/VY+	-40°C to +105°C	48 QFND-EP**	No
MAX9288GTM+	-40°C to +105°C	48 TQFN-EP**	No
MAX9288GTM/V+	-40°C to +105°C	48 TQFN-EP**	No
MAX9290GTM+	-40°C to +105°C	48 TQFN-EP**	Yes†
MAX9290GTM/V+	-40°C to +105°C	48 TQFN-EP**	Yes†

V denotes an automotive qualified product.

+Denotes a lead(Pb)-free/RoHS-compliant package.

**EP = Exposed pad.

†HDCP parts require registration with Digital Content Protection, LLC.

Chip Information

PROCESS: CMOS

Package Information

For the latest package outline information and land patterns (footprints), go to www.maximintegrated.com/packages. Note that a "+", "#", or "-" in the package code indicates RoHS status only. Package drawings may show a different suffix character, but the drawing pertains to the package regardless of RoHS status.

PACKAGE TYPE	PACKAGE CODE	OUTLINE NO.	LAND PATTERN NO.
48 TQFN-EP	T4877+4	21-0144	90-0130
48 QFND-EP	G4877Y+3	21-0585	90-0457

Revision History

REVISION NUMBER	REVISION DATE	DESCRIPTION	PAGES CHANGED
0	3/14	Initial release	—
1	9/14	Added simplified diagram, removed Table 1 and renumbered the subsequent tables, clarified functions, removed future product designations, and corrected typos	1, 28, 33, 48, 49, 51–56, 59, 66, 67, 69–72, 74–77, 79–82, 84, 85, 86, 88–102
2	11/15	Clarified timing requirements	8, 27, 30, 50
3	3/17	Various updates, beginning with <i>AC Electrical Characteristics</i>	12, 18, 21, 26, 58, 61, 62, 67, 71, 80, 84, 86, 90, 99

For pricing, delivery, and ordering information, please contact Maxim Direct at 1-888-629-4642, or visit Maxim Integrated's website at www.maximintegrated.com.

Maxim Integrated cannot assume responsibility for use of any circuitry other than circuitry entirely embodied in a Maxim Integrated product. No circuit patent licenses are implied. Maxim Integrated reserves the right to change the circuitry and specifications without notice at any time. The parametric values (min and max limits) shown in the Electrical Characteristics table are guaranteed. Other parametric values quoted in this data sheet are provided for guidance.