

COSEL

Unit type

Ordering information

**MMC8A**

**MMC 8A -1 -□**

① ② ③ ④

**RoHS**

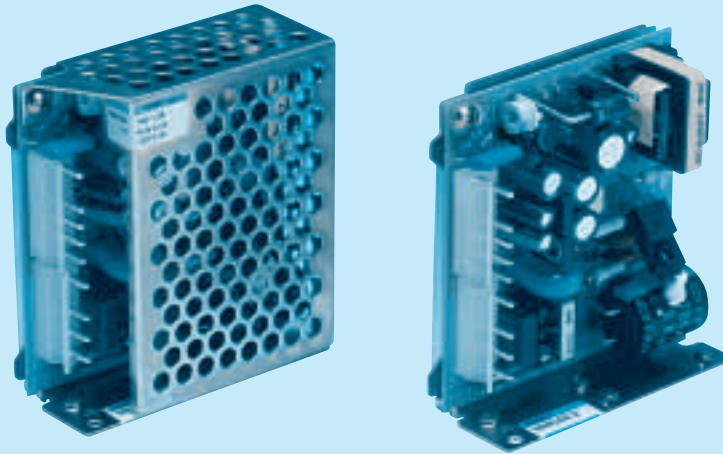

- ① Series name
- ② Output wattage
- ③ Output voltage combination
- ④ Optional  
G : Low leakage current  
N : with Cover

MMC

MODEL	MMC8A-1	MMC8A-2	MMC8A-3
DC OUTPUT	V1	+5V 1.2A	+5V 1.1A
	V2	+12V 0.1A	+15V 0.1A
	V3	-12V 0.1A	-15V 0.1A

**SPECIFICATIONS**

	MODEL	MMC8A-1	MMC8A-2	MMC8A-3							
INPUT	VOLTAGE[V]	AC85 - 132 1 φ or DC110 - 170									
	CURRENT[A]	ACIN 100V	0.3typ (Io=100%)								
	FREQUENCY[Hz]	47 - 440 or DC									
	EFFICIENCY[%]	ACIN 100V	68typ (Io=100%)								
	INRUSH CURRENT[A]	ACIN 100V	20typ (Io=100%)								
OUTPUT	VOLTAGE[V]	+5	+12	-12	+5	+15	-15	+5	+12	-5	
	CURRENT[A]	1.2	0.1	0.1	1.1	0.1	0.1	1.2	0.1	0.1	
	MINIMUM CURRENT[A]	0	0	0	0	0	0	0	0	0	
	LINE REGULATION[mV]	20max	48max	48max	20max	60max	60max	20max	48max	20max	
	LOAD REGULATION[mV]	60max	120max	120max	60max	150max	150max	60max	120max	100max	
	RIPPLE[mVp-p]	*1	80max	120max	120max	80max	120max	120max	80max	120max	120max
	RIPPLE NOISE[mVp-p]	*1	120max	150max	150max	120max	150max	150max	120max	150max	150max
	TEMPERATURE REGULATION[mV]	0 to +50°C	50max	350max	350max	50max	350max	350max	50max	350max	350max
	START-UP TIME[ms]	100max (ACIN 85V, Io=100%)									
	HOLD-UP TIME[ms]	15typ (ACIN 85V, Io=100%)									
PROTECTION CIRCUIT	OVERCURRENT PROTECTION	Works over 105% of rating and recovers automatically									
	INPUT-CASE, OUTPUT	AC2.000V 1minute, DC500V 50MΩmin (At Room Temperature)									
ISOLATION	OUTPUT-CASE	AC500V 1minute, DC500V 50MΩmin (At Room Temperature)									
	OUTPUT-OUTPUT(V1-V2,V3)	AC100V 1minute, DC100V 10MΩmin (At Room Temperature)									
ENVIRONMENT	OPERATING TEMP., HUMID. AND ALTITUDE	0 to +65°C, 20 - 90%RH (Non condensing) (Refer to DERATING CURVE), 3,000m (10,000feet) max									
	STORAGE TEMP., HUMID. AND ALTITUDE	-20 to +75°C, 20 - 90%RH (Non condensing), 9,000m (30,000feet) max									
	VIBRATION	10 - 55Hz, 19.6m/s <sup>2</sup> (2G), 3minutes period, 30minutes each along X, Y and Z axis									
	IMPACT	98.0m/s <sup>2</sup> (10G), 20ms, once each X, Y and Z axis									
SAFETY AND NOISE REGULATIONS	AGENCY APPROVALS	UL60950-1, C-UL Complies with DEN-AN									
	CONDUCTED NOISE	Complies with FCC-B									

\*1 Measured by 20MHz oscilloscope or Ripple-Noise meter (equivalent to KEISOKU-GIKEN : RM101).  
 \* When units are operated with chassis and cover, derating is required.  
 \* Avoid prolonged use under over-load.

External view

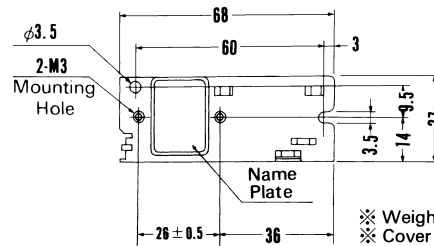
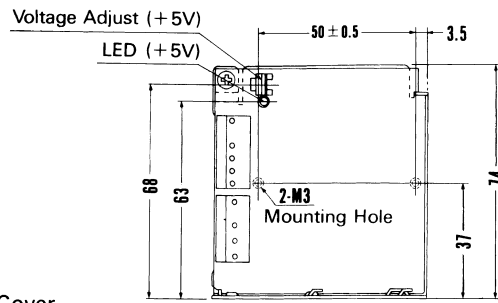
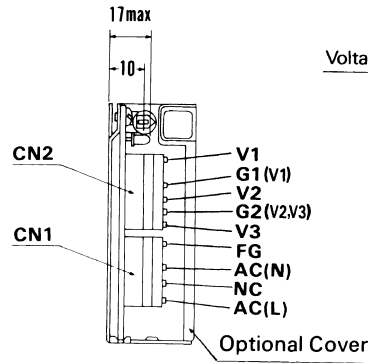

\*V1 is isolated from V2 and V3.

I/O Connector	Mating Connector	Terminal
CN1	5289-4A	5199-04
CN2	5277-05A	5196-05

Chain : 5194PBT  
Loose : 5194PRTL  
(Mfr: Molex)

\*Weight: 150g or less  
\*Cover is optional  
\*Tolerance: ±1  
\*Dimensions in mm.

\*Mounting torque : 0.6N·m (6.3kgf·cm) max

Performance data

■ STATIC CHARACTERISTICS (MMC8A-1)

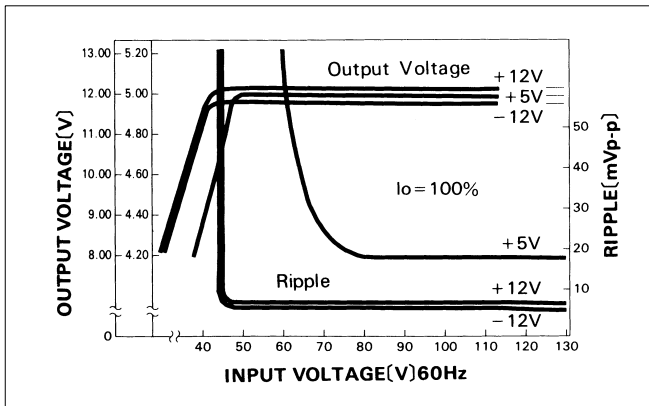

■ RISE TIME & FALL TIME (MMC8A-1)

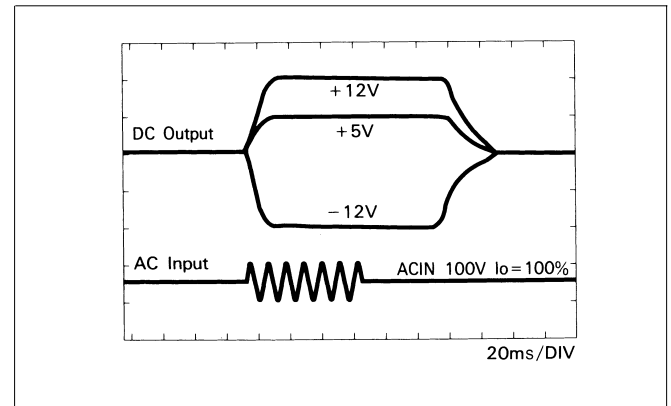

■ OVERCURRENT CHARACTERISTICS (MMC8A-1)

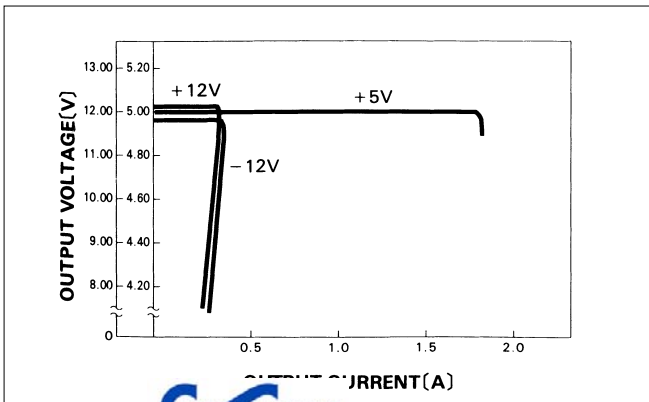

■ DERATING CURVE

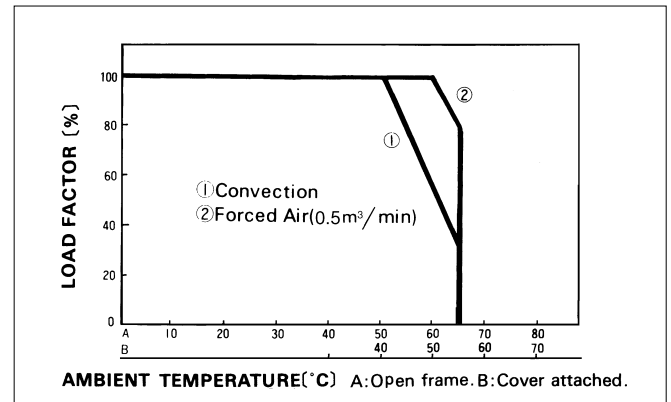

COSEL

Unit type

Ordering information

MMC50A

MMC 50A -1 -□

① ② ③ ④

RoHS

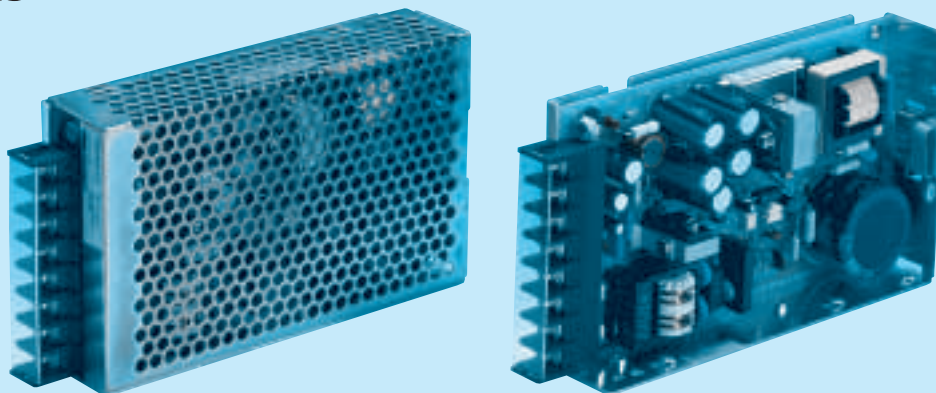

- ① Series name
- ② Output wattage
- ③ Output voltage combination
- ④ Optional
  - C : with Coating
  - G : Low leakage current
  - J : Connector type
  - N : with Cover

MMC

MODEL	MMC50A-1	MMC50A-2	MMC50A-3	MMC50A-4
DC OUTPUT	V1	+5V 5.0A	+5V 5.0A	+5V 5.0A
	V2	+12V 1.5(Peak 2.0)A	+15V 1.2A	+12V 1.5(Peak 2.0)A
	V3	-12V 0.5A	-15V 0.5A	-5V 0.5A
				-12V 0.3A

SPECIFICATIONS

	MODEL	MMC50A-1	MMC50A-2	MMC50A-3	MMC50A-4									
INPUT	VOLTAGE[V]	AC85 - 132 1 φ or DC110 - 170												
	CURRENT[A]	ACIN 100V	1.5typ (Io=100%)											
	FREQUENCY[Hz]	47 - 440 or DC												
	EFFICIENCY[%]	ACIN 100V	70typ (Io=100%)											
	INRUSH CURRENT[A]	ACIN 100V	30typ (Io=100%) (At cold start)											
OUTPUT	VOLTAGE[V]	+5	+12	-12	+5	+15	-15	+5	+12	-5	+5	+12	-12	
	CURRENT[A]	*1	5	1.5 (Peak2)	0.5	5	1.2	0.5	5	1.5 (Peak2)	0.5	7	1 (Peak1.5)	0.3
	MINIMUM CURRENT[A]	0.75	0	0	0.75	0	0	0.75	0	0	0.75	0	0	
	LINE REGULATION[mV]	20max	48max	100max	20max	60max	60max	20max	48max	20max	20max	48max	48max	
	LOAD REGULATION[mV]	40max	150max	150max	40max	150max	150max	40max	150max	100max	40max	150max	150max	
	RIPPLE[mVp-p]	*2	80max	120max	120max	80max	120max	120max	80max	120max	120max	80max	120max	120max
	RIPPLE NOISE[mVp-p]	*2	120max	150max	150max	120max	150max	150max	120max	150max	150max	120max	150max	150max
	TEMPERATURE REGULATION[mV]	0 to +50°C	50max	350max	350max	50max	350max	350max	50max	350max	350max	50max	350max	350max
	START-UP TIME[ms]	100max (ACIN 85V, Io=100%)												
	HOLD-UP TIME[ms]	15typ (ACIN 85V, Io=100%)												
	OUTPUT VOLTAGE ADJUSTMENT RANGE[V]	5.00 - 5.25	Fixed	Fixed	5.00 - 5.25	Fixed	Fixed	5.00 - 5.25	Fixed	Fixed	5.00 - 5.25	Fixed	Fixed	
OUTPUT VOLTAGE SETTING[V]	—	11.40 to 12.60	-11.40 to -12.60	—	14.25 to 15.75	-14.25 to -15.75	—	11.40 to 12.60	-4.75 to -5.25	—	11.40 to 12.60	-11.40 to -12.60		
PROTECTION CIRCUIT	OVERCURRENT PROTECTION	Works over 105% of rating (V2 works at peak current) and recovers automatically												
	OVERVOLTAGE PROTECTION	Works at 115 - 140% of rating (+5V)												
ISOLATION	INPUT-CASE, OUTPUT	AC2,000V 1minute, DC500V 50MΩmin (At Room Temperature)												
	OUTPUT-CASE	AC500V 1minute, DC500V 50MΩmin (At Room Temperature)												
	OUTPUT-OUTPUT(V1-V2,V3)	AC100V 1minute, DC100V 10MΩmin (At Room Temperature)												
ENVIRONMENT	OPERATING TEMP.,HUMID.AND ALTITUDE	0 to +65°C, 20 - 90%RH (Non condensing) (Refer to DERATING CURVE), 3,000m (10,000feet) max												
	STORAGE TEMP.,HUMID.AND ALTITUDE	-20 to +75°C, 20 - 90%RH (Non condensing), 9,000m (30,000feet) max												
	VIBRATION	10 - 55Hz, 19.6m/s <sup>2</sup> (2G), 3minutes period, 30minutes each along X, Y and Z axis												
	IMPACT	196.1m/s <sup>2</sup> (20G), 11ms, once each X, Y and Z axis												
SAFETY AND NOISE REGULATIONS	AGENCY APPROVALS	UL60950-1, C-UL Complies with DEN-AN												
	CONDUCTED NOISE	Complies with FCC-A												

\*1 Peak current for 30 seconds.  
 \*2 Measured by 20MHz oscilloscope or Ripple-Noise meter(equivalent to KEISOKU-GIKEN : RM101).  
 \* When units are operated with chassis and cover, derating is required.  
 \* Avoid prolonged use und

**External view**

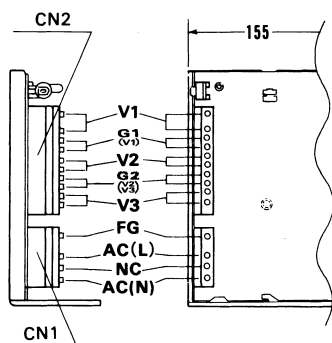

I/O Connector	Mating Connector	Terminal
CN1	5289-4A	5199-04
CN2	5277-10A	5196-10

Chain : 5194PBT  
Loose : 5194PBT

※ Use J cover for connector type.

Connector type

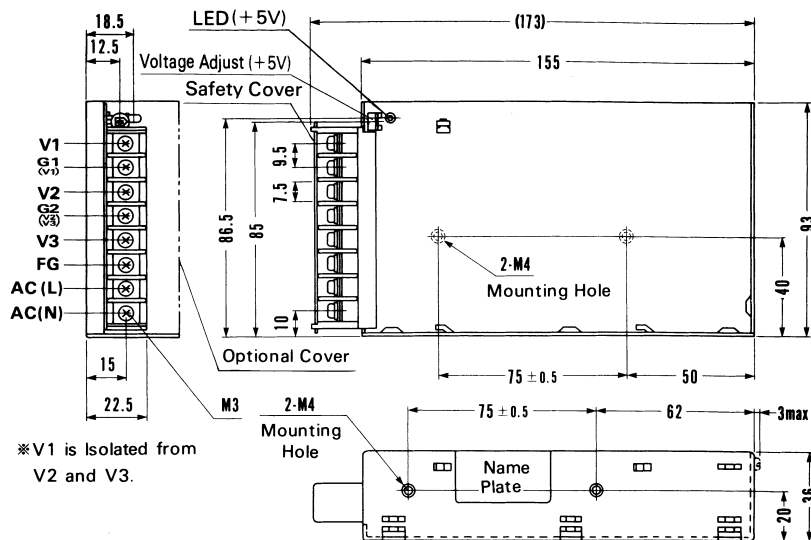

※ V1 is isolated from V2 and V3.

※ Mounting torque : 1.2N·m (12.8kgf·cm) max

Barrier strip type

※ Weight: 400g or less.

※ Cover is optional

※ Tolerance: ±1 ※ Dimensions in mm.

**Performance data**

**STATIC CHARACTERISTICS (MMC50A-1)**

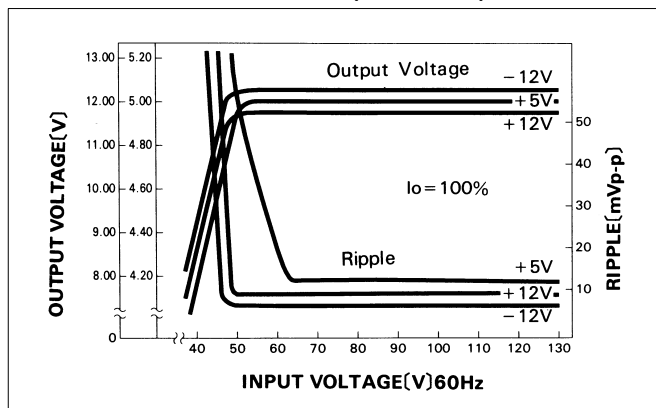

**RISE TIME & FALL TIME (MMC50A-1)**

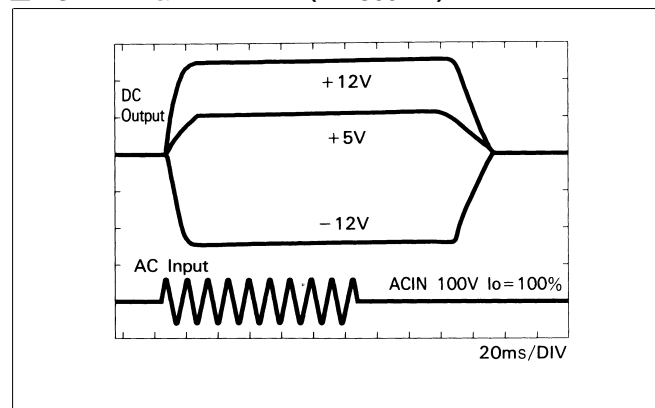

**OVERCURRENT CHARACTERISTICS (MMC50A-1)**

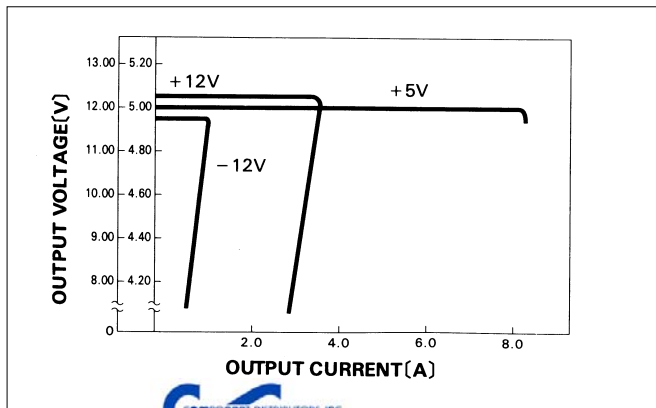

**DERATING CURVE**

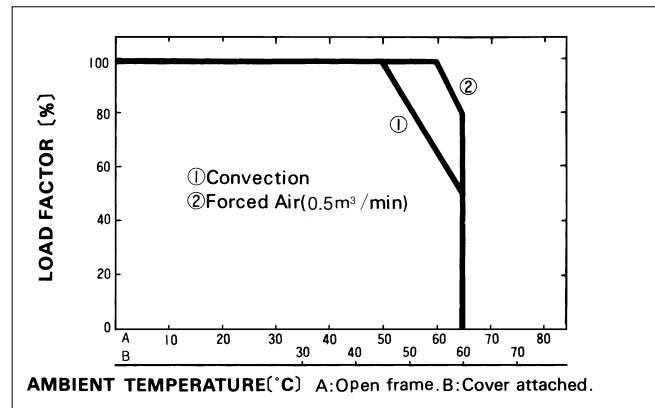

COSEL

Unit type

Ordering information

MMC75A

MMC 75A -1 -□

① ② ③ ④

RoHS

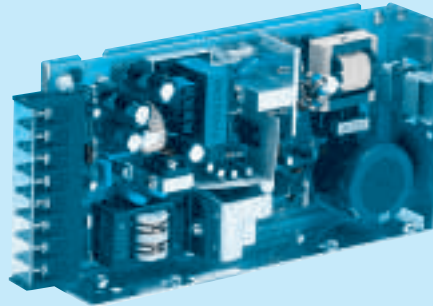
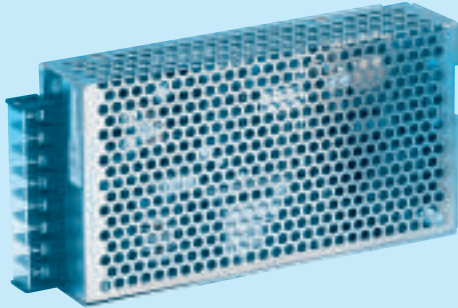

- ① Series name
- ② Output wattage
- ③ Output voltage combination
- ④ Optional
  - C : with Coating
  - G : Low leakage current
  - J : Connector type
  - N : with Cover

RoHS : Please consult us for details

MODEL	MMC75A-1	MMC75A-2	MMC75A-3	MMC75A-4
DC OUTPUT	V1	+5V 8.0A	+5V 8.0A	+5V 8.0A
	V2	+12V 2.5A	+15V 1.8A	+12V 2.5A
	V3	-12V 0.5A	-15V 0.5A	-5V 0.5A

## SPECIFICATIONS

	MODEL	MMC75A-1	MMC75A-2	MMC75A-3	MMC75A-4									
INPUT	VOLTAGE[V]	AC85 - 132 1φ or DC110 - 170												
	CURRENT[A]	2.1typ (Io=100%)												
	FREQUENCY[Hz]	47 - 440 or DC												
	EFFICIENCY[%]	75typ (Io=100%)												
	INRUSH CURRENT[A]	20typ (Io=100%)												
OUTPUT	VOLTAGE[V]	+5	+12	-12	+5	+15	-15	+5	+12	-5	+5	+12	-12	
	CURRENT[A]	8	2.5	0.5	8	1.8	0.5	8	2.5	0.5	6	3.2	0.5	
	MINIMUM CURRENT[A]	1.5	0	0	1.5	0	0	1.5	0	0	1.5	0	0	
	LINE REGULATION[mV]	20max	48max	48max	20max	60max	60max	20max	48max	20max	20max	48max	100max	
	LOAD REGULATION[mV]	40max	100max	150max	40max	120max	150max	40max	100max	100max	40max	100max	150max	
	RIPPLE[mVp-p]	*1 80max	120max	120max	80max	120max	120max	80max	120max	120max	80max	120max	120max	
	RIPPLE NOISE[mVp-p]	*1 120max	150max	150max	120max	150max	150max	120max	150max	150max	120max	150max	150max	
	TEMPERATURE REGULATION[mV]	0 to +50°C	50max	120max	350max	50max	150max	350max	50max	120max	350max	50max	120max	350max
	START-UP TIME[ms]	200max (ACIN 85V, Io=100%)												
	HOLD-UP TIME[ms]	15typ (ACIN 85V, Io=100%)												
OUTPUT VOLTAGE ADJUSTMENT RANGE[V]	5.00 - 5.25	Fixed	Fixed	5.00 - 5.25	Fixed	Fixed	5.00 - 5.25	Fixed	Fixed	5.00 - 5.25	Fixed	Fixed		
OUTPUT VOLTAGE SETTING[V]	—	11.40 to 12.60	-11.40 to -12.60	—	14.25 to 15.75	-14.25 to -15.75	—	11.40 to 12.60	-4.75 to -5.25	—	11.40 to 12.60	-11.40 to -12.60		
PROTECTION CIRCUIT	OVERCURRENT PROTECTION	Works over 105% of rating and recovers automatically												
	OVERVOLTAGE PROTECTION	Works at 115 - 140% of rating (+5V)												
ISOLATION	INPUT-CASE, OUTPUT	AC2,000V 1minute, DC500V 50MΩmin (At Room Temperature)												
	OUTPUT-CASE	AC500V 1minute, DC500V 50MΩmin (At Room Temperature)												
	OUTPUT-OUTPUT(V1-V2,V3)	AC100V 1minute, DC100V 10MΩmin (At Room Temperature)												
ENVIRONMENT	OPERATING TEMP., HUMID. AND ALTITUDE	0 to +65°C, 20 - 90%RH (Non condensing) (Refer to DERATING CURVE), 3,000m (10,000feet) max												
	STORAGE TEMP., HUMID. AND ALTITUDE	-20 to +75°C, 20 - 90%RH (Non condensing), 9,000m (30,000feet) max												
	VIBRATION	10 - 55Hz, 19.6m/s <sup>2</sup> (2G), 3minutes period, 30minutes each along X, Y and Z axis												
	IMPACT	196.1m/s <sup>2</sup> (20G), 11ms, once each X, Y and Z axis												
SAFETY AND NOISE REGULATIONS	AGENCY APPROVALS	UL60950-1, C-UL Complies with DEN-AN												
	CONDUCTED NOISE	Complies with FCC-A												

\*1 Measured by 20MHz oscilloscope or Ripple-Noise meter (equivalent to KEISOKU-GIKEN : RM101).  
 \* When units are operated with chassis and cover, derating is required.  
 \* Avoid prolonged use under over-load.

External view

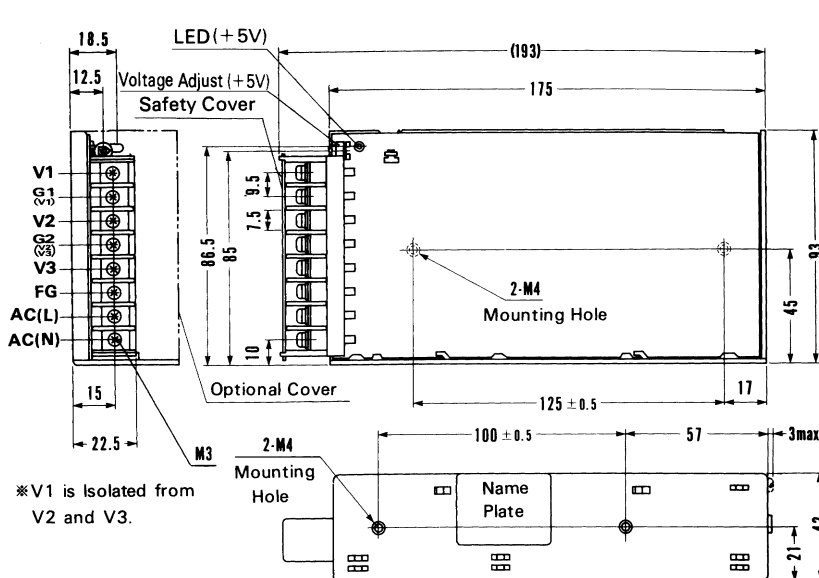
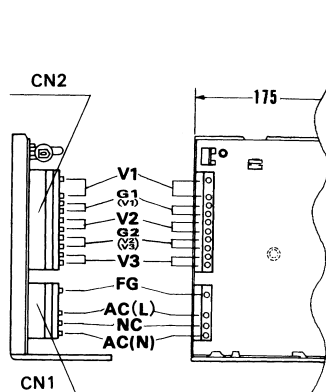

I/O Connector	Mating Connector	Terminal
CN1	5289-4A	5199-04
CN2	5277-10A	5196-10

Chain : 5194PBT

Loose : 5194PBTL

(Mfr: Molex)

※Use J cover for connector type.

Connector type

※ Mounting torque : 1.2N·m (12.8kgf·cm) max

Barrier strip type

※ Weight : 600g or less

※ Cover is optional

※ Tolerance : ± 1

※ Dimensions in mm.

Performance data

■ STATIC CHARACTERISTICS (MMC75A-4)

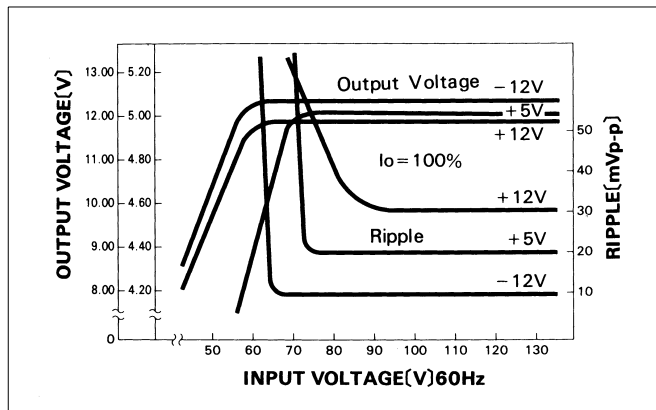

■ RISE TIME & FALL TIME (MMC75A-4)

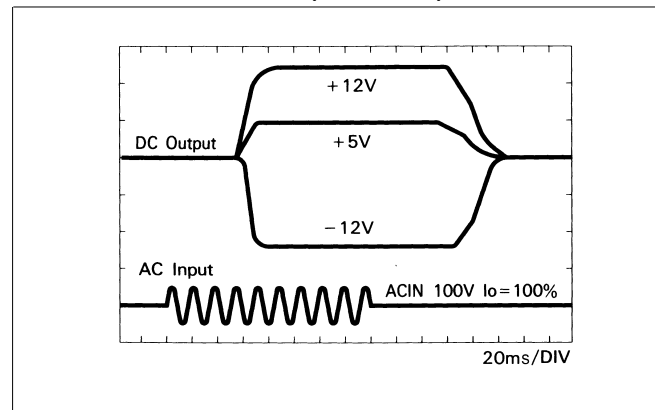

■ OVERCURRENT CHARACTERISTICS (MMC75A-4)

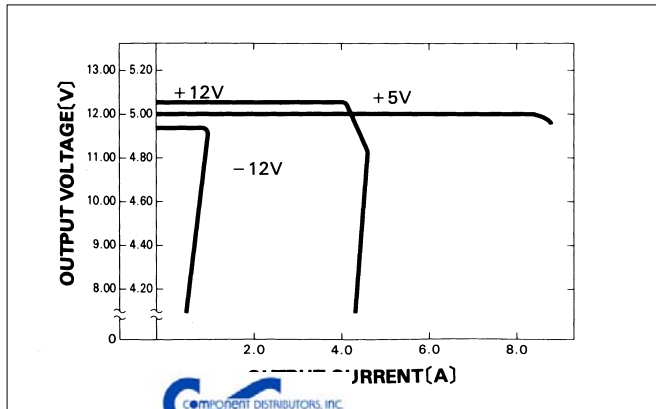

■ DERATING CURVE

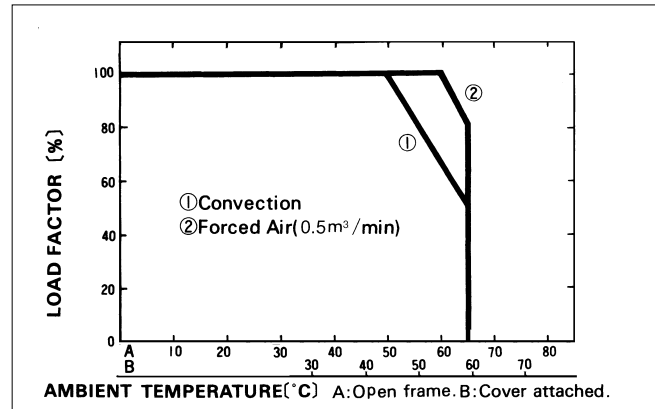

# MMC100A

MMC 100A -1 -□

① ② ③ ④

RoHS

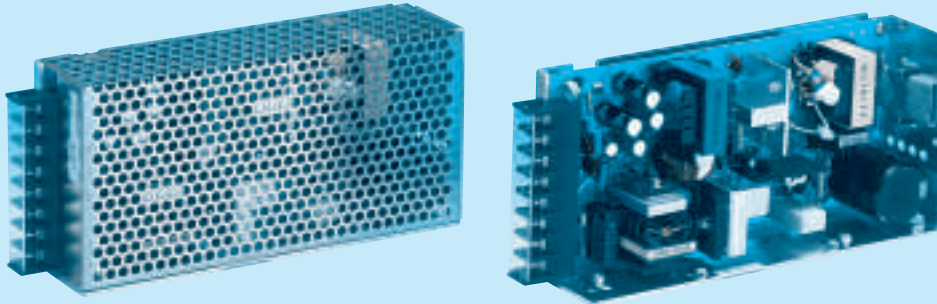

RoHS : Please consult us for details

- ① Series name
- ② Output wattage
- ③ Output voltage combination
- ④ Optional
  - C : with Coating
  - G : Low leakage current
  - J : Connector type
  - N : with Cover

MODEL		MMC100A-1	MMC100A-2	MMC100A-3	MMC100A-4
DC OUTPUT	V1	+5V 13.0A	+5V 13.0A	+5V 13.0A	+5V 8.0A
	V2	+12V 2.0A	+15V 1.5A	+12V 2.0A	+12V 4.0A
	V3	-12V 1.0A	-15V 1.0A	-5V 1.0A	-12V 1.0A

## SPECIFICATIONS

	MODEL	MMC100A-1			MMC100A-2			MMC100A-3			MMC100A-4			
INPUT	VOLTAGE[V]	AC85 - 132 1φ or DC110 - 170												
	CURRENT[A]	ACIN 100V	2.8typ (Io=100%)											
	FREQUENCY[Hz]	47 - 440 or DC												
	EFFICIENCY[%]	ACIN 100V	75typ (Io=100%)											
	INRUSH CURRENT[A]	ACIN 100V	25typ (Io=100%)											
OUTPUT	VOLTAGE[V]	+5	+12	-12	+5	+15	-15	+5	+12	-5	+5	+12	-12	
	CURRENT[A]	13	2	1	13	1.5	1	13	2	1	8	4	1	
	MINIMUM CURRENT[A]	1.5	0	0	1.5	0	0	1.5	0	0	1.5	0	0	
	LINE REGULATION[mV]	20max	48max	48max	20max	60max	60max	20max	48max	20max	20max	48max	100max	
	LOAD REGULATION[mV]	40max	100max	150max	40max	120max	150max	40max	100max	100max	40max	100max	150max	
	RIPPLE[mVp-p]	*1 80max	120max	120max	80max	120max	120max	80max	120max	120max	80max	120max	120max	
	RIPPLE NOISE[mVp-p]	*1 120max	150max	150max	120max	150max	150max	120max	150max	150max	120max	150max	150max	
	TEMPERATURE REGULATION[mV]	0 to +50°C	50max	120max	350max	50max	150max	350max	50max	120max	350max	50max	120max	350max
	START-UP TIME[ms]	200max (ACIN 85V, Io=100%)												
	HOLD-UP TIME[ms]	15typ (ACIN 85V, Io=100%)												
OUTPUT VOLTAGE ADJUSTMENT RANGE[V]	5.00 - 5.25	Fixed	Fixed	5.00 - 5.25	Fixed	Fixed	5.00 - 5.25	Fixed	Fixed	5.00 - 5.25	Fixed	Fixed		
OUTPUT VOLTAGE SETTING[V]	—	11.40 to 12.60	-11.40 to -12.60	—	14.25 to 15.75	-14.25 to -15.75	—	11.40 to 12.60	-4.75 to -5.25	—	11.40 to 12.60	-11.40 to -12.60		
PROTECTION CIRCUIT	OVERCURRENT PROTECTION	Works over 105% of rating and recovers automatically												
	OVERVOLTAGE PROTECTION	Works at 115 - 140% of rating (+5V)												
ISOLATION	INPUT-CASE, OUTPUT	AC2,000V 1minute, DC500V 50MΩmin (At Room Temperature)												
	OUTPUT-CASE	AC500V 1minute, DC500V 50MΩmin (At Room Temperature)												
	OUTPUT-OUTPUT(V1-V2,V3)	AC100V 1minute, DC100V 10MΩmin (At Room Temperature)												
ENVIRONMENT	OPERATING TEMP., HUMID. AND ALTITUDE	0 to +65°C, 20 - 90%RH (Non condensing) (Refer to DERATING CURVE), 3,000m (10,000feet) max												
	STORAGE TEMP., HUMID. AND ALTITUDE	-20 to +75°C, 20 - 90%RH (Non condensing), 9,000m (30,000feet) max												
	VIBRATION	10 - 55Hz, 19.6m/s <sup>2</sup> (2G), 3minutes period, 30minutes each along X, Y and Z axis												
	IMPACT	196.1m/s <sup>2</sup> (20G), 11ms, once each X, Y and Z axis												
SAFETY AND NOISE REGULATIONS	AGENCY APPROVALS	UL60950-1, C-UL Complies with DEN-AN												
	CONDUCTED NOISE	Complies with FCC-A												

\*1 Measured by 20MHz oscilloscope or Ripple-Noise meter (equivalent to KEISOKU-GIKEN : RM101).  
 \* When units are operated with chassis and cover, derating is required.  
 \* Avoid prolonged use under over-load.

External view

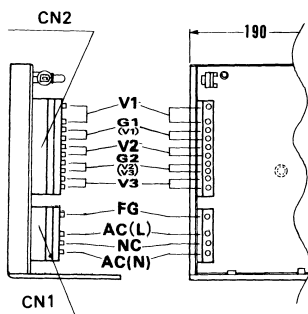

I/O Connector	Mating Connector	Terminal
CN1	5289-4A	5199-04
CN2	5277-10A	5196-10

(Mfr: Molex)

Connector type

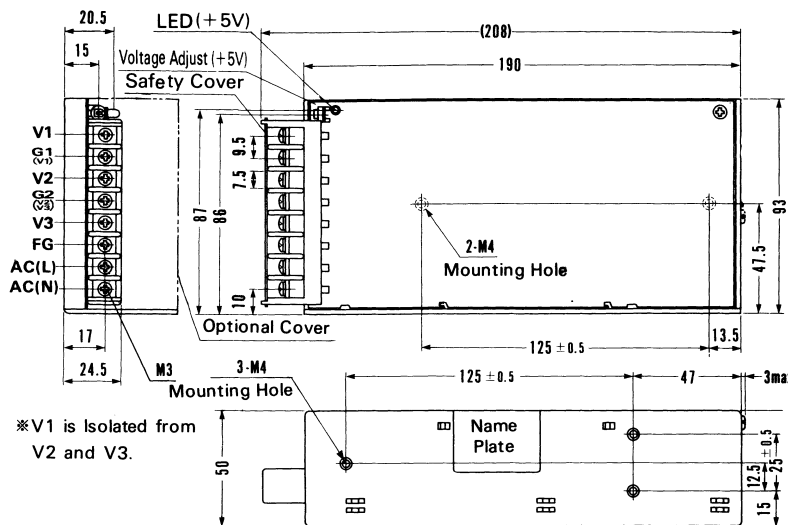

※V1 is isolated from V2 and V3.

※Mounting torque : 1.2N·m (12.8kgf·cm) max

※Weight: 700g or less.

※Cover is optional.

※Tolerance: ±1

※Dimensions in mm.

Barrier strip type

Performance data

■STATIC CHARACTERISTICS (MMC100A-4)

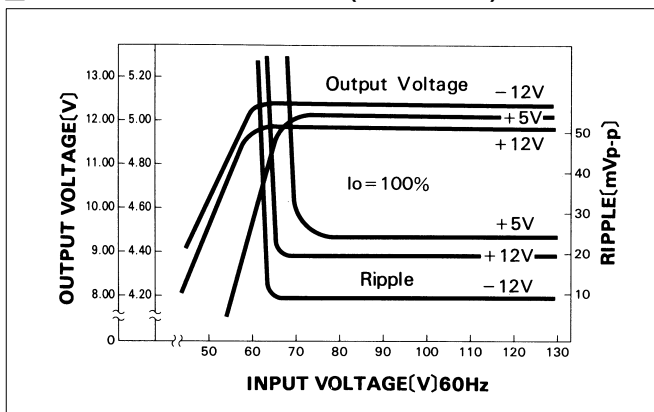

■RISE TIME & FALL TIME (MMC100A-4)

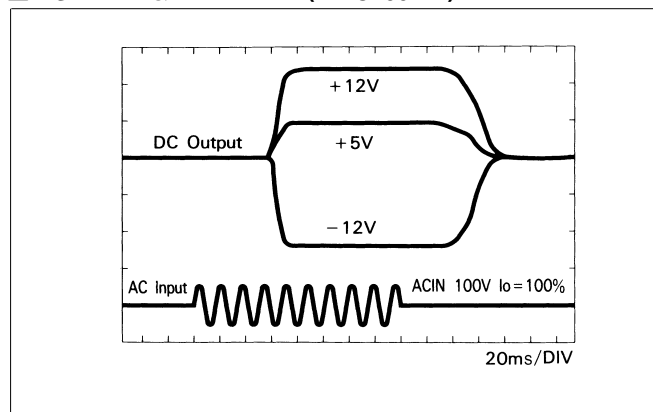

■OVERCURRENT CHARACTERISTICS (MMC100A-4)

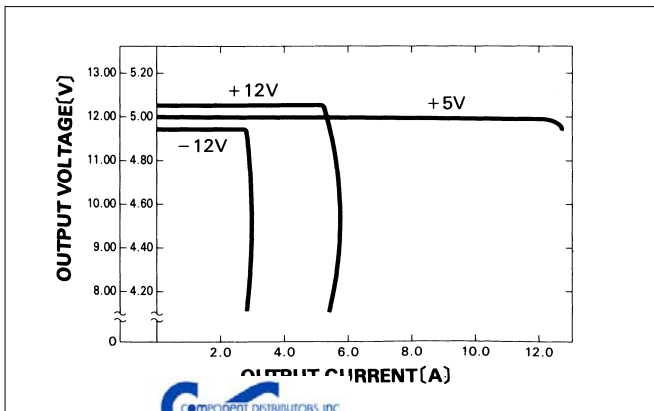

■DERATING CURVE

