

DATA SHEET

SSTV16859

2.5 V 13-bit to 26-bit SSTL_2
registered buffer for stacked DDR DIMM

Product data
2000 Dec 01
File under Integrated Circuits — ICL03

2002 Feb 19

2.5 V 13-bit to 26-bit SSTL_2 registered buffer for stacked DDR DIMM

SSTV16859

FEATURES

- Stub-series terminated logic for 2.5 V V_{DD} (SSTL_2)
- Optimized for stacked DDR (Double Data Rate) SDRAM applications
- Supports SSTL_2 signal inputs as per JESD 8–9
- Flow-through architecture optimizes PCB layout
- ESD classification testing is done to JEDEC Standard JESD22. Protection exceeds 2000 V to HBM per method A114.
- Latch-up testing is done to JEDEC Standard JESD78, which exceeds 100 mA.
- Supports efficient low power standby operation
- Full DDR 200/266 solution for stacked DIMMs at 2.5 V when used with PCKV857
- See SSTV16857 for JEDEC compliant register support in unstacked DIMM applications
- See SSTV16856 for driver/buffer version with mode select.

DESCRIPTION

The SSTV16859 is a 13-bit to 26-bit SSTL_2 registered driver with differential clock inputs, designed to operate between 2.3 V and 2.7 V. All inputs are compatible with the JEDEC standard for SSTL_2 with V_{REF} normally at $0.5 \times V_{DD}$, except the LVCMOS reset (\overline{RESET}) input. All outputs are SSTL_2, Class II compatible which can be used for standard stub-series applications or capacitive loads. Master reset (\overline{RESET}) asynchronously resets all registers to zero.

The SSTV16859 is intended to be incorporated into standard DIMM (Dual In-Line Memory Module) designs defined by JEDEC, such as

DDR (Double Data Rate) SDRAM and SDRAM II Memory Modules. Different from traditional SDRAM, DDR SDRAM transfers data on both clock edges (rising and falling), thus doubling the peak bus bandwidth. A DDR DRAM rated at 133 MHz will have a burst rate of 266 MHz.

The device data inputs consist of different receivers. One differential input is tied to the input pin while the other is tied to a reference input pad, which is shared by all inputs.

The clock input is fully differential (CK and \overline{CK}) to be compatible with DRAM devices that are installed on the DIMM. Data are registered at the crossing of CK going high, and \overline{CK} going low. However, since the control inputs to the SDRAM change at only half the data rate, the device must only change state on the positive transition of the CK signal. In order to be able to provide defined outputs from the device even before a stable clock has been supplied, the device has an asynchronous input pin (\overline{RESET}), which when held to the LOW state, resets all registers and all outputs to the LOW state.

The device supports low-power standby operation. When \overline{RESET} is low, the differential input receivers are disabled, and undriven (floating) data, clock, and reference voltage (V_{REF}) inputs are allowed. In addition, when \overline{RESET} is low, all registers are reset, and all outputs are forced low. The LVCMOS \overline{RESET} input must always be held at a valid logic high or low level.

To ensure defined outputs from the register before a stable clock has been supplied, \overline{RESET} must be held in the low state during power-up.

In the DDR DIMM application, \overline{RESET} is specified to be completely asynchronous with respect to CK and \overline{CK} . Therefore, no timing relationship can be guaranteed between the two. When entering \overline{RESET} , the register will be cleared and the outputs will be driven low. As long as the data inputs are low, and the clock is stable during the time from the low-to-high transition of \overline{RESET} until the input receivers are fully enabled, the outputs will remain low.

Available in 64-pin plastic thin shrink small outline package.

QUICK REFERENCE DATA

GND = 0 V; $T_{amb} = 25^\circ\text{C}$; $t_r = t_f \leq 2.5$ ns

SYMBOL	PARAMETER	CONDITIONS	TYPICAL	UNIT
t_{PHL}/t_{PLH}	Propagation delay; CLK to Qn	$C_L = 30$ pF; $V_{DD} = 2.5$ V	2.4	ns
C_I	Input capacitance	$V_{CC} = 2.5$ V	2.7	pF

NOTE:

1. C_{PD} is used to determine the dynamic power dissipation (P_D in μW) $P_D = C_{PD} \times V_{CC}^2 \times f_i + \sum (C_L \times V_{CC}^2 \times f_o)$ where:
 f_i = input frequency in MHz; C_L = output load capacity in pF; f_o = output frequency in MHz; V_{CC} = supply voltage in V;
 $\sum (C_L \times V_{CC}^2 \times f_o)$ = sum of the outputs.

ORDERING INFORMATION

PACKAGES	TEMPERATURE RANGE	ORDER CODE	DWG NUMBER
64-Pin Plastic TSSOP	0 to +70 °C	SSTV16859DGG	SOT646AA1
96-Ball Plastic LFBGA	0 to +70 °C	SSTV16859EC	SOT536-1
56-Terminal Plastic HVQFN	0 to +70 °C	SSTV16859BS	SOT684-1

2.5 V 13-bit to 26-bit SSTL_2 registered buffer for stacked DDR DIMM

SSTV16859

PIN CONFIGURATION

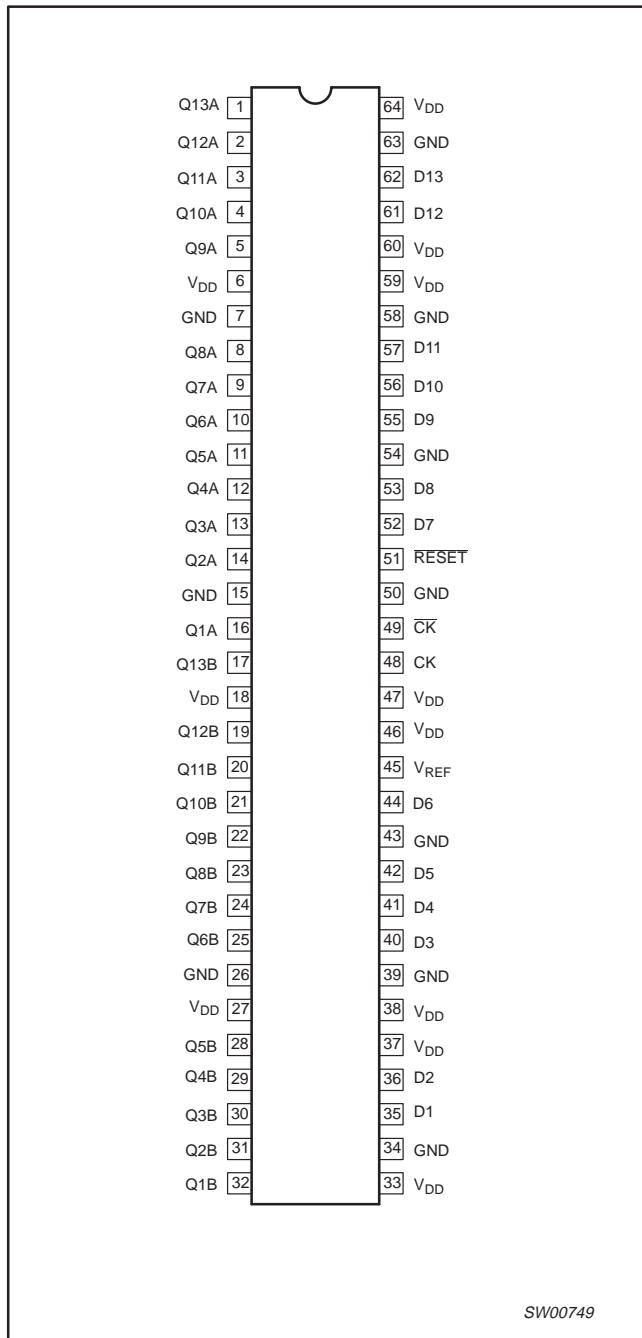

PIN DESCRIPTION

PIN NUMBER	SYMBOL	NAME AND FUNCTION
1, 2, 3, 4, 5, 8, 9, 10, 11, 12, 13, 14, 16	Q13A–Q1A	Data output
17, 19, 20, 21, 22, 23, 24, 25, 28, 29, 30, 31, 32	Q13B–Q1B	Data output
6, 18, 27, 33, 37, 38, 46, 47, 59, 60, 64	V _{DD}	Power supply voltage
7, 15, 26, 34, 39, 43, 50, 54, 58, 63	GND	Ground
35, 36, 40, 41, 42, 44, 52, 53, 55, 56, 57, 61, 62	D1–D13	Data input: clocked in on the crossing of the rising edge of CK and the falling edge of CK
45	V _{REF}	Input reference voltage
48, 49	CK, \overline{CK}	Positive and negative master clock input
51	RESET	Asynchronous reset input: resets registers and disables data and clock differential input receivers

2.5 V 13-bit to 26-bit SSTL_2 registered buffer for stacked DDR DIMM

SSTV16859

56-TERMINAL CONFIGURATION

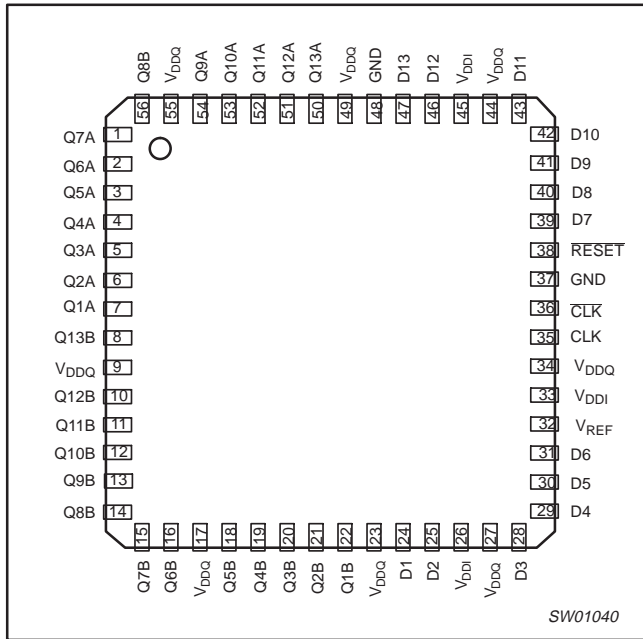

TERMINAL DESCRIPTION

TERMINAL NUMBER	SYMBOL	NAME AND FUNCTION
1, 2, 3, 4, 5, 6, 7, 50, 51, 52, 53, 54, 56	Q13A–Q1A	Data output
10, 11, 12, 13, 14, 15, 16, 18, 19, 20, 21, 22	Q13B–Q1B	Data output
9, 17, 23, 27, 34, 44, 49, 55	V _{DDQ}	Power supply voltage
26, 33, 45	V _{DDI}	Power supply voltage
37, 48	GND	Ground
24, 25, 28, 29, 30, 31, 39, 40, 41, 42, 43, 46, 47	D1–D13	Data input: clocked in on the crossing of the rising edge of CK and the falling edge of \overline{CK}
32	V _{REF}	Input reference voltage
35, 36	CK, \overline{CK}	Positive and negative master clock input
51	\overline{RESET}	Asynchronous reset input: resets registers and disables data and clock differential input receivers

2.5 V 13-bit to 26-bit SSTL_2 registered buffer for stacked DDR DIMM

SSTV16859

BALL CONFIGURATION

	1	2	3	4	5	6
A	—	—	—	—	—	—
B	Q12A	Q13A	GND	GND	—	—
C	Q10A	Q11A	GND	GND	—	—
D	Q8A	Q9A	V _{DDQ}	V _{DDQ}	D13	D12
E	Q6A	Q7A	V _{DDQ}	V _{DDQ}	D11	D10
F	Q4A	Q5A	V _{DDQ}	V _{DDQ}	D9	D8
G	Q2A	Q3A	GND	GND	D7	RESET
H	Q1A	Q13B	GND	GND	—	$\overline{\text{CK}}$
J	Q12B	Q11B	GND	V _{REF}	—	CK
K	Q10B	Q9B	V _{DDQ}	V _{DDQ}	—	—
L	Q8B	Q7B	V _{DDQ}	V _{DDQ}	D5	D6
M	Q6B	Q5B	V _{DDQ}	V _{DDQ}	D3	D4
N	Q4B	Q3B	GND	GND	D1	D2
P	Q2B	Q1B	GND	GND	—	—
R	—	—	—	—	—	—
T	—	—	—	—	—	—

SW00944

LOGIC DIAGRAM

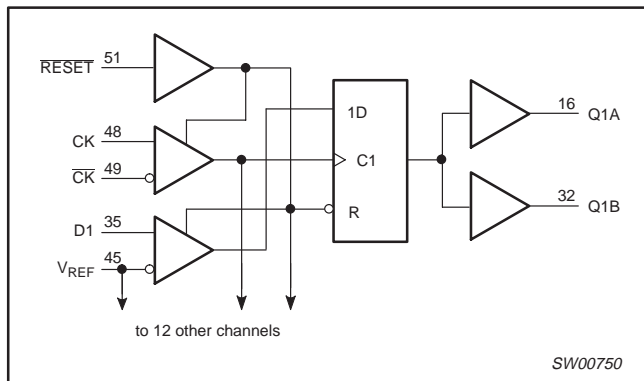

SW00750

H	↑	↓	L	L
H	↑	↓	H	H
H	L or H	L or H	X	Q ₀
L	X or floating	X or floating	X or floating	L

H = High voltage level
 L = Low voltage level
 ↓ = High-to-Low transition
 ↑ = Low-to-High transition
 X = Don't care

FUNCTION TABLE (each flip flop)

INPUTS				OUTPUT
RESET	CLK	$\overline{\text{CLK}}$	D	Q

2.5 V 13-bit to 26-bit SSTL_2 registered buffer for stacked DDR DIMM

SSTV16859

ABSOLUTE MAXIMUM RATINGS¹

SYMBOL	PARAMETER	CONDITION	LIMITS		UNIT
			MIN	MAX	
V_{DD}	Supply voltage range		-0.5	+3.6	V
V_I	Input voltage range	Notes 2 and 3	-0.5	$V_{DD} + 0.5$	V
V_O	Output voltage range	Notes 2 and 3	-0.5	$V_{DD} + 0.5$	V
I_{IK}	Input clamp current	$V_I < 0$ or $V_I > V_{DD}$	—	±50	mA
I_{OK}	Output clamp current	$V_O < 0$ or $V_O > V_{DD}$	—	±50	mA
I_O	Continuous output current	$V_O = 0$ to V_{DD}	—	±50	mA
	Continuous current through each V_{DD} or GND		—	±100	mA
T_{stg}	Storage temperature range		-65	+150	°C

NOTES:

- Stresses beyond those listed under “absolute maximum ratings” may cause permanent damage to the device. These are stress ratings only and functional operation of the device at these or any other conditions beyond those indicated under “recommended operating conditions” is not implied. Exposure to absolute-maximum-rated conditions for extended periods may affect device reliability.
- The input and output negative-voltage ratings may be exceeded if the input and output current ratings are observed.
- This value is limited to 3.6 V maximum.
- The performance capability of a high-performance integrated circuit in conjunction with its thermal environment can create junction temperatures that are detrimental to reliability. The maximum junction temperature of this integrated circuit should not exceed 150°C.

RECOMMENDED OPERATING CONDITIONS¹

SYMBOL	PARAMETER	CONDITIONS	MIN	TYP	MAX	UNIT
V_{DD}	Supply voltage		V_{DD}	—	2.7	V
V_{REF}	Reference voltage ($V_{REF} = V_{DD}/2$)		1.15	1.25	1.35	V
V_{TT}	Termination voltage		$V_{REF} - 40$ mV	V_{REF}	$V_{REF} + 40$ mV	V
V_I	Input voltage		0	—	V_{DD}	V
V_{IH}	AC HIGH-level input voltage	Data inputs	$V_{REF} + 310$ mV	—	—	V
V_{IL}	AC LOW-level input voltage	Data inputs	—	—	$V_{REF} - 310$ mV	V
V_{IH}	DC HIGH-level input voltage	Data inputs	$V_{REF} + 150$ mV	—	—	V
V_{IL}	DC LOW-level input voltage	Data inputs	—	—	$V_{REF} - 150$ mV	V
V_{IH}	HIGH-level input voltage	RESET	1.7	—	V_{DD}	V
V_{IL}	LOW-level input voltage		0.0	—	0.7	V
V_{ICR}	Common-mode input range	CK, \overline{CK}	0.97	—	1.53	V
V_{ID}	Differential input voltage	CK, \overline{CK}	360	—	—	mV
I_{OH}	HIGH-level output current		—	—	-20	mA
I_{OL}	LOW-level output current		—	—	20	mA
T_{amb}	Operating free-air temperature range		0	—	+70	°C

NOTE:

- The RESET input of the device must be held at V_{DD} or GND to ensure proper device operation. The differential inputs must not be floating, unless RESET is low.

2.5 V 13-bit to 26-bit SSTL_2 registered buffer for stacked DDR DIMM

SSTV16859

DC ELECTRICAL CHARACTERISTICS

Over recommended operating conditions. Voltages are referenced to GND (ground = 0 V).

SYMBOL	PARAMETER	TEST CONDITIONS	LIMITS			UNIT	
			$T_{amb} = 0 \text{ to } +70 \text{ }^\circ\text{C}$				
			MIN	TYP	MAX		
V_{IK}		$I_I = -18 \text{ mA}$, $V_{DD} = 2.3 \text{ V}$	—	—	-1.2	V	
V_{OH}		$I_{OH} = -100 \text{ } \mu\text{A}$, $V_{DD} = 2.3 \text{ to } 2.7 \text{ V}$	$V_{DD} - 0.2$	—	—	V	
		$I_{OH} = -16 \text{ mA}$, $V_{DD} = 2.3 \text{ V}$	1.95	—	—		
V_{OL}		$I_{OL} = 100 \text{ } \mu\text{A}$, $V_{DD} = 2.3 \text{ to } 2.7 \text{ V}$	—	—	0.2	V	
		$I_{OL} = 16 \text{ mA}$, $V_{DD} = 2.3 \text{ V}$	—	—	0.35		
I_I	All inputs	$V_I = V_{DD}$ or GND, $V_{DD} = 2.7 \text{ V}$	—	—	± 5	μA	
I_{DD}	Static standby	RESET = GND	IO = 0, $V_{DD} = 2.7 \text{ V}$	—	—	0.01	mA
	Static operating	RESET = V_{DD} , $V_I = V_{IH(AC)}$ or $V_{IL(AC)}$		—	—	45	
I_{DDD}	Dynamic operating – clock only	RESET = V_{DD} , $V_I = V_{IH(AC)}$ or $V_{IL(AC)}$, CK and $\overline{\text{CK}}$ switching 50% duty cycle.	IO = 0, $V_{DD} = 2.7 \text{ V}$	90	—	—	$\mu\text{A/ clock MHz}$
	Dynamic operating – per each data input	RESET = V_{DD} , $V_I = V_{IH(AC)}$ or $V_{IL(AC)}$, CK and $\overline{\text{CK}}$ switching 50% duty cycle. One data input switching at half clock frequency, 50% duty cycle.		20	—	—	$\mu\text{A/ clock MHz/ data input}$
r_{OH}	Output high	$I_{OH} = -20 \text{ mA}$, $V_{DD} = 2.3 \text{ to } 2.7 \text{ V}$	7	—	20	Ω	
r_{OL}	Output low	$I_{OL} = 20 \text{ mA}$, $V_{DD} = 2.3 \text{ to } 2.7 \text{ V}$	7	—	20	Ω	
$r_{O(\Delta)}$	$ r_{OH} - r_{OL} $ each separate bit	$I_O = 20 \text{ mA}$, $T_{amb} = 25^\circ\text{C}$, $V_{DD} = 2.5 \text{ V}$	—	—	4	Ω	
C_i	Data inputs	$V_I = V_{REF} \pm 310 \text{ mV}$, $V_{DD} = 2.5 \text{ V}$	2.5	2.74	3.5	pF	
	CK and $\overline{\text{CK}}$	$V_{ICR} = 1.25 \text{ V}$, $V_{I(PP)} = 360 \text{ mV}$, $V_{DD} = 2.5 \text{ V}$	2.5	3.15	3.5		
	RESET	$V_I = V_{DD}$ or GND, $V_{DD} = 2.5 \text{ V}$	—	2.27	—		

2.5 V 13-bit to 26-bit SSTL_2 registered buffer for stacked DDR DIMM

SSTV16859

TIMING REQUIREMENTS

Over recommended operating conditions; $T_{amb} = 0$ to $+70$ °C (unless otherwise noted) (see Figure 1)

SYMBOL	PARAMETER	TEST CONDITIONS	LIMITS		UNIT
			$V_{DD} = 2.5 V \pm 0.2 V$		
			MIN	MAX	
f_{clock}	Clock frequency		—	200	MHz
t_w	Pulse duration, CK, \overline{CK} HIGH or LOW		2.5	—	ns
t_{act}	Differential inputs active time	Notes 1, 2	—	22	ns
t_{inact}	Differential inputs inactive time	Notes 1, 3	—	22	ns
t_{su}	Setup time, fast slew rate (see Notes 4 and 6)	Data before $CK\uparrow$, $\overline{CK}\downarrow$	0.75		ns
	Setup time, slow slew rate (see Notes 5 and 6)		0.9		
t_h	Hold time, fast slew rate (see Notes 4 and 6)	Data after $CK\uparrow$, $\overline{CK}\downarrow$	0.75		ns
	Hold time, slow slew rate (see Notes 5 and 6)		0.9		
t_{SL}	Output slew		1	6	V/ns

NOTES:

1. This parameter is not necessarily production tested.
2. Data inputs must be below a minimum time of t_{act} max, after \overline{RESET} is taken high.
3. Data and clock inputs must be held at valid levels (not floating) a minimum time of t_{inact} max, after \overline{RESET} is taken low.
4. For data signal input slew rate ≥ 1 V/ns.
5. For data signal input slew rate ≥ 0.5 V/ns and < 1 V/ns.
6. CK, \overline{CK} signals input slew rates are ≥ 1 V/ns.

SWITCHING CHARACTERISTICS

Over recommended operating conditions; $T_{amb} = 0$ to $+70$ °C; $V_{DD} = 2.3 - 2.7 V$.
Class I, $V_{REF} = V_{TT} = V_{DD} \times 0.5$ and $C_L = 10$ pF (unless otherwise noted) (see Figure 1)

SYMBOL	FROM (INPUT)	TO (OUTPUT)	LIMITS		UNIT
			$V_{DD} = 2.5 V \pm 0.2 V$		
			MIN	MAX	
f_{max}			200	—	MHz
t_{pd}	CK and \overline{CK}	Q	1.1	2.8	ns
t_{PHL}	\overline{RESET}	Q	1.1	5	ns

2.5 V 13-bit to 26-bit SSTL_2 registered buffer for stacked DDR DIMM

SSTV16859

OUTPUT BUFFER CHARACTERISTICS

The following table describes output-buffer Voltage vs. Current (V/I) characteristics that are sufficient to meet the requirements of registered DDR DIMM performance and timings. These characteristics are not necessarily production tested but can be guaranteed by design or characterization. Compliance with these curves is not mandatory if it can be adequately demonstrated that alternate characteristics meet the requirements of the registered DDR DIMM application.

VOLTAGE (V)	PULL-DOWN		PULL-UP	
	I (mA) MIN	I (mA) MAX	I (mA) MIN	I (mA) MAX
0.0	0	0	0	0
0.1	7	11	7	10
0.2	14	23	14	20
0.3	21	34	21	30
0.4	28	44	27	40
0.5	33	54	33	49
0.6	39	64	38	59
0.7	44	74	44	68
0.8	48	83	49	76
0.9	52	91	53	84
1.0	56	99	57	93
1.1	59	107	61	100
1.2	61	114	64	108
1.3	63	121	67	115
1.4	64	127	69	121
1.5	66	133	70	128
1.6	66	138	72	134
1.7	67	142	73	139
1.8	67	146	74	144
1.9	67	149	74	148
2.0	67	151	75	152
2.1	68	153	75	156
2.2	68	154	75	159
2.3	68	155	76	161
2.4	—	156	—	163
2.5	—	157	—	165
2.6	—	157	—	167
2.7	—	157	—	168

PARAMETER MEASUREMENT INFORMATION

TEST CIRCUIT

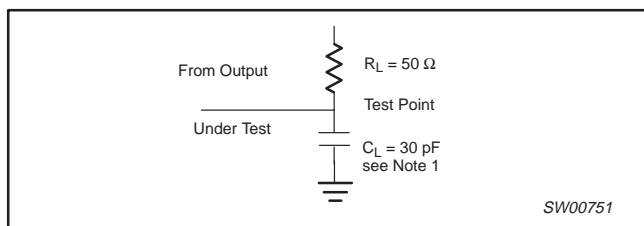

Figure 1. Load circuitry

NOTE:

1. C_L includes probe and jig capacitance.

2.5 V 13-bit to 26-bit SSTL_2 registered buffer for stacked DDR DIMM

SSTV16859

AC WAVEFORMS

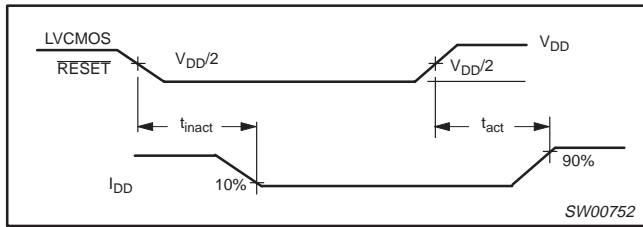

Waveform 1. Inputs active and inactive times (see Note 1)

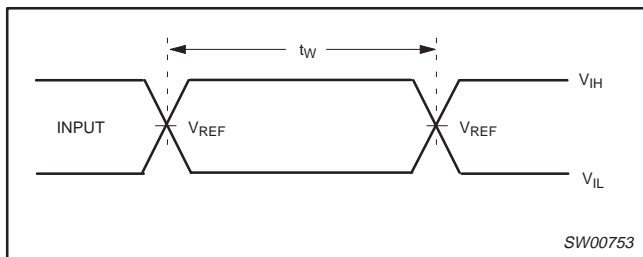

Waveform 2. Pulse duration

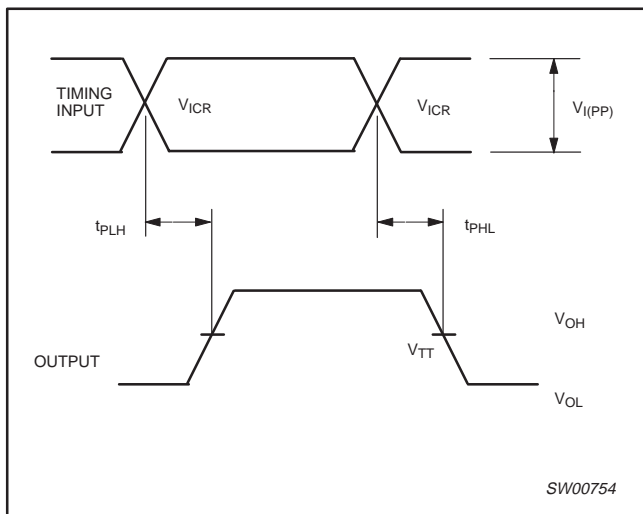

Waveform 3. Propagation delay times

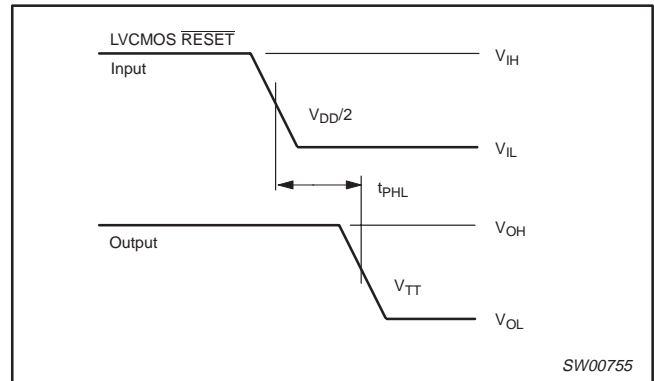

Waveform 4. Propagation delay times

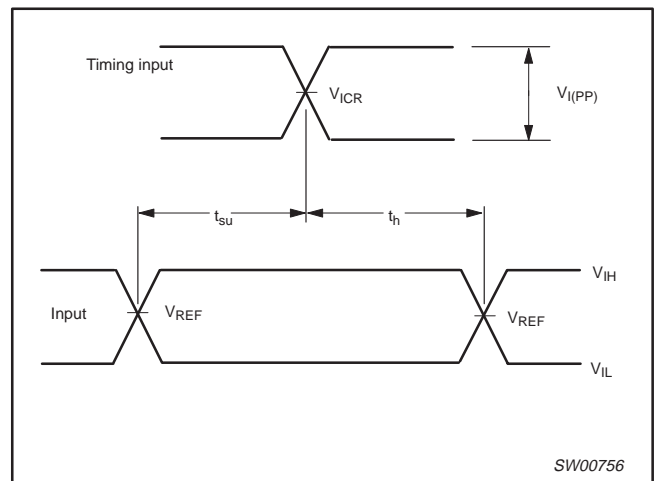

Waveform 5. Setup and hold times

NOTES:

1. I_{DD} tested with clock and data inputs held at V_{DD} or GND, and $I_O = 0$ mA.
2. All input pulses are supplied by generators having the following characteristics: $PRR \leq 10$ MHz, $Z_O = 50 \Omega$, input slew rate = 1 V/ns $\pm 20\%$ (unless otherwise specified).
3. The outputs are measured one at a time with one transition per measurement.
4. $V_{TT} = V_{REF} = V_{DD}/2$
5. $V_{IH} = V_{REF} + 310$ mV (ac voltage levels) for differential inputs. $V_{IH} = V_{DD}$ for LVC MOS input.
6. $V_{IL} = V_{REF} - 310$ mV (ac voltage levels) for differential inputs. $V_{IL} = \text{GND}$ for LVC MOS input.
7. t_{PLH} and t_{PHL} are the same as t_{pd} .

2.5 V 13-bit to 26-bit SSTL_2
registered buffer for stacked DDR DIMM

SSTV16859

TSSOP64: plastic thin shrink small outline package; 64 leads; body width 6.1 mm

SOT646-1

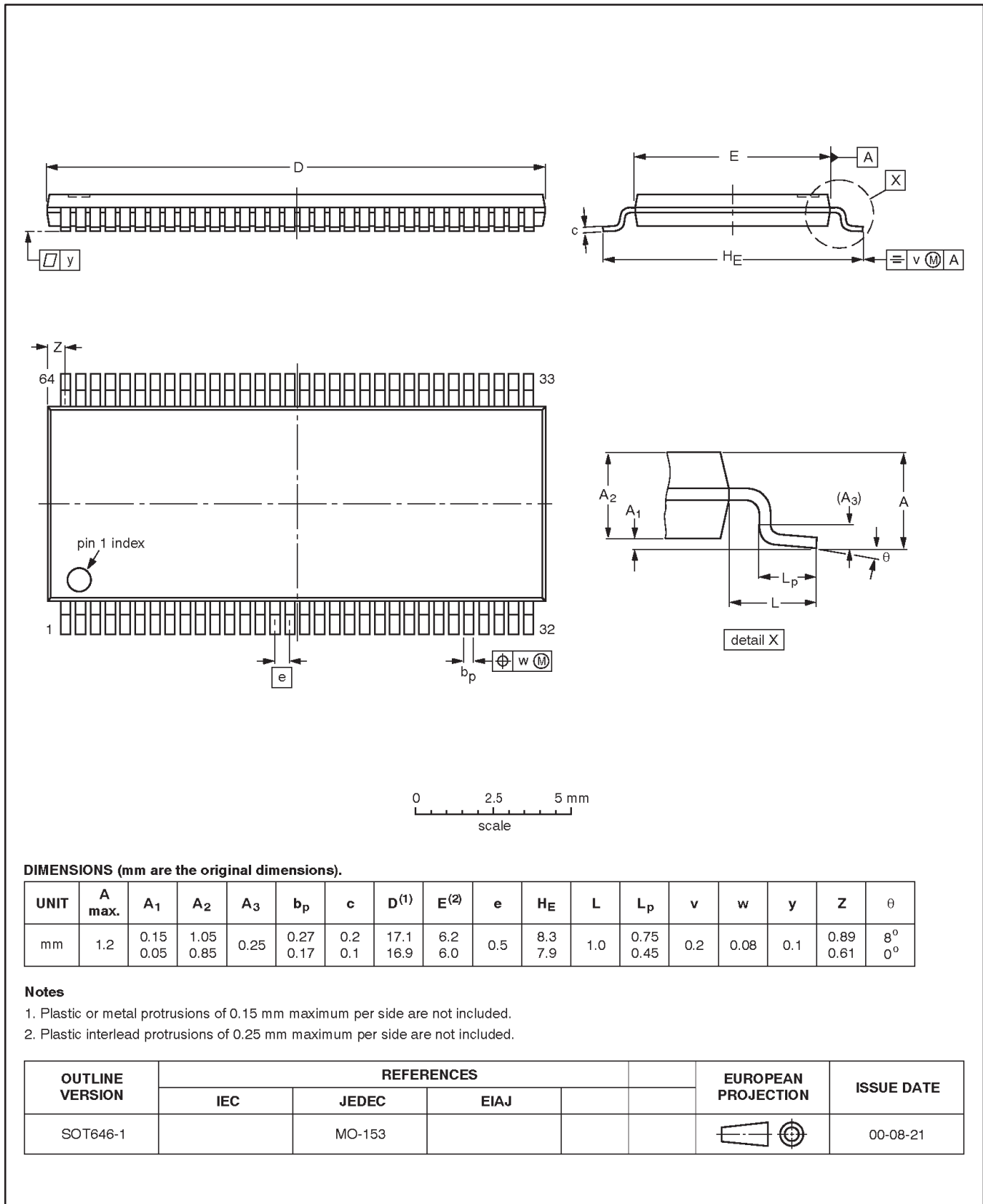

2.5 V 13-bit to 26-bit SSTL_2
registered buffer for stacked DDR DIMM

SSTV16859

LFBGA96: plastic low profile fine-pitch ball grid array package; 96 balls;
body 13.5 x 5.5 x 1.05 mm

SOT536-1

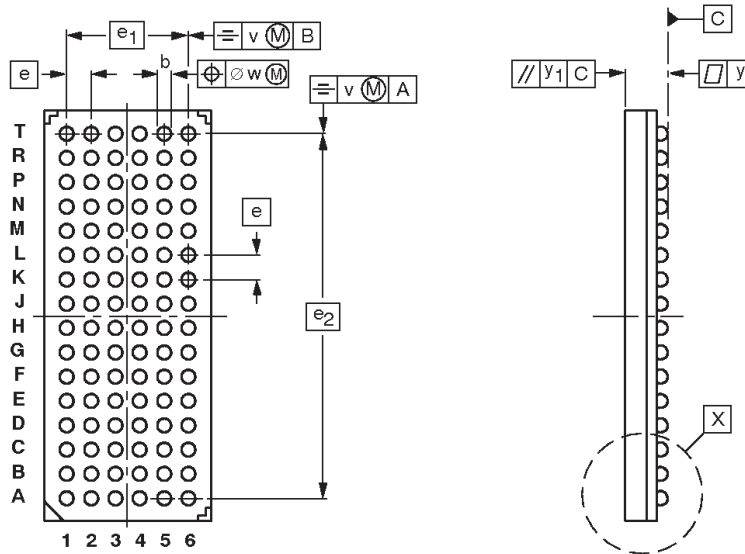
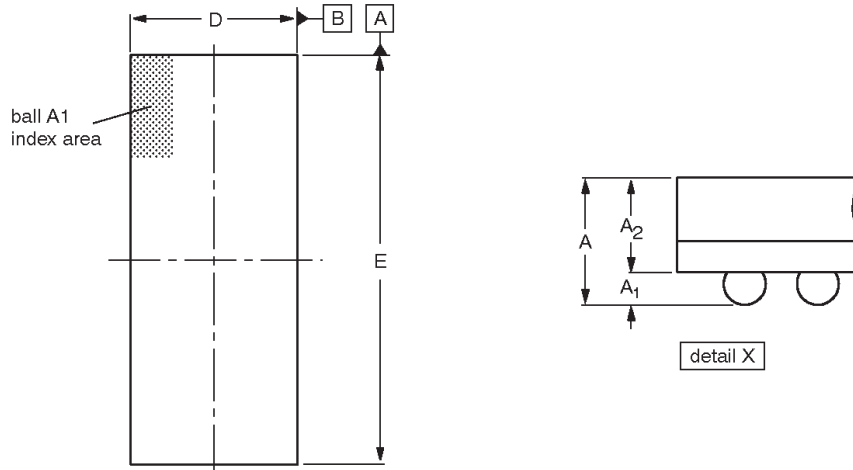

DIMENSIONS (mm are the original dimensions)

UNIT	A _{max.}	A ₁	A ₂	b	D	E	e	e ₁	e ₂	v	w	y	y ₁
mm	1.5	0.41 0.31	1.2 0.9	0.51 0.41	5.6 5.4	13.6 13.4	0.8	4.0	12.0	0.15	0.1	0.1	0.2

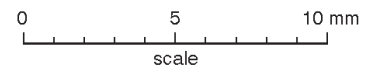

OUTLINE VERSION	REFERENCES				EUROPEAN PROJECTION	ISSUE DATE
	IEC	JEDEC	EIAJ			
SOT536-1						99-12-02-00-03-04

2.5 V 13-bit to 26-bit SSTL_2 registered buffer for stacked DDR DIMM

SSTV16859

HVQFN56: plastic, heatsink very thin quad flat package; no leads; 56 terminals;
body 8 x 8 x 0.85 mm

SOT684-1

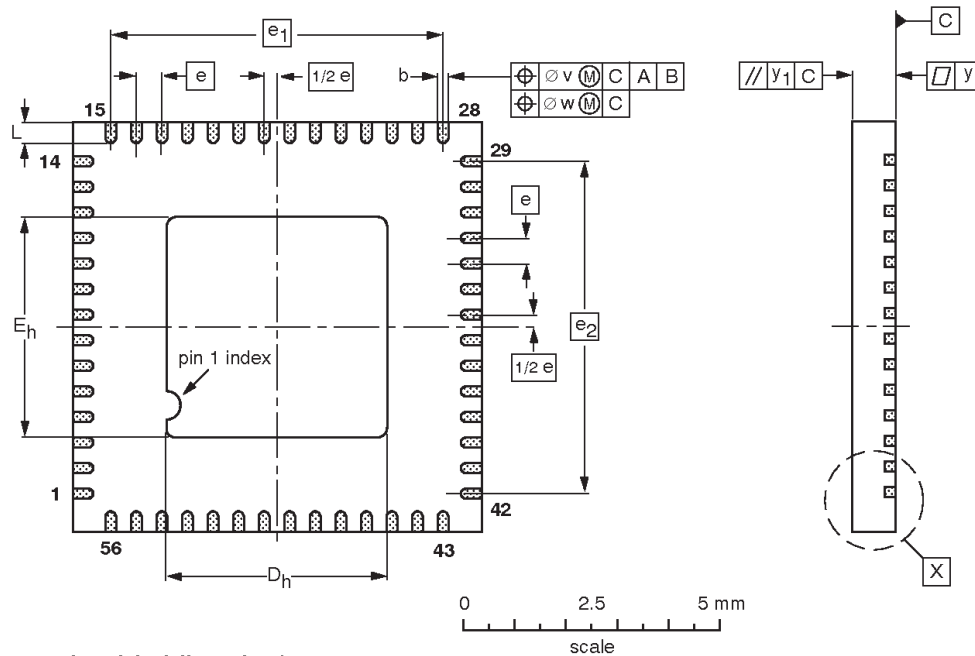
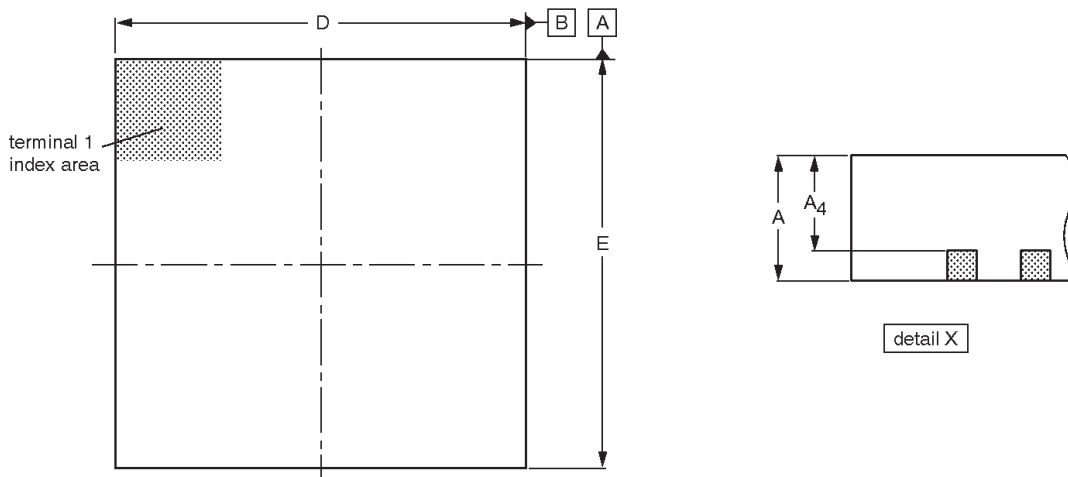

DIMENSIONS (mm are the original dimensions)

UNIT	A max.	A ₄ max.	b	D ⁽¹⁾	D _h	E ⁽¹⁾	E _h	e	e ₁	e ₂	L	v	w	y	y ₁
mm	1.00	0.80	0.35 0.18	8.05 7.95	4.45 4.15	8.05 7.95	4.45 4.15	0.5	6.5	6.5	0.50 0.30	0.10	0.10	0.05	0.1

Note

1. Plastic or metal protrusions of 0.076 mm maximum per side are not included.

OUTLINE VERSION	REFERENCES				EUROPEAN PROJECTION	ISSUE DATE
	IEC	JEDEC	EIAJ			
SOT684-1		MO-220				01-06-12 01-08-08

2.5 V 13-bit to 26-bit SSTL_2 registered buffer for stacked DDR DIMM

SSTV16859

Data sheet status

Data sheet status ^[1]	Product status ^[2]	Definitions
Objective data	Development	This data sheet contains data from the objective specification for product development. Philips Semiconductors reserves the right to change the specification in any manner without notice.
Preliminary data	Qualification	This data sheet contains data from the preliminary specification. Supplementary data will be published at a later date. Philips Semiconductors reserves the right to change the specification without notice, in order to improve the design and supply the best possible product.
Product data	Production	This data sheet contains data from the product specification. Philips Semiconductors reserves the right to make changes at any time in order to improve the design, manufacturing and supply. Changes will be communicated according to the Customer Product/Process Change Notification (CPCN) procedure SNW-SQ-650A.

[1] Please consult the most recently issued data sheet before initiating or completing a design.

[2] The product status of the device(s) described in this data sheet may have changed since this data sheet was published. The latest information is available on the Internet at URL <http://www.semiconductors.philips.com>.

Definitions

Short-form specification — The data in a short-form specification is extracted from a full data sheet with the same type number and title. For detailed information see the relevant data sheet or data handbook.

Limiting values definition — Limiting values given are in accordance with the Absolute Maximum Rating System (IEC 60134). Stress above one or more of the limiting values may cause permanent damage to the device. These are stress ratings only and operation of the device at these or at any other conditions above those given in the Characteristics sections of the specification is not implied. Exposure to limiting values for extended periods may affect device reliability.

Application information — Applications that are described herein for any of these products are for illustrative purposes only. Philips Semiconductors make no representation or warranty that such applications will be suitable for the specified use without further testing or modification.

Disclaimers

Life support — These products are not designed for use in life support appliances, devices or systems where malfunction of these products can reasonably be expected to result in personal injury. Philips Semiconductors customers using or selling these products for use in such applications do so at their own risk and agree to fully indemnify Philips Semiconductors for any damages resulting from such application.

Right to make changes — Philips Semiconductors reserves the right to make changes, without notice, in the products, including circuits, standard cells, and/or software, described or contained herein in order to improve design and/or performance. Philips Semiconductors assumes no responsibility or liability for the use of any of these products, conveys no license or title under any patent, copyright, or mask work right to these products, and makes no representations or warranties that these products are free from patent, copyright, or mask work right infringement, unless otherwise specified.

Contact information

For additional information please visit
<http://www.semiconductors.philips.com>. Fax: +31 40 27 24825

© Koninklijke Philips Electronics N.V. 2002
All rights reserved. Printed in U.S.A.

Date of release: 02-02

For sales offices addresses send e-mail to:
sales.addresses@www.semiconductors.philips.com

Document order number:

9397 750 09464

Let's make things better.