



# VN05NSP

## HIGH SIDE SMART POWER SOLID STATE RELAY

TYPE	V <sub>DSS</sub>	R <sub>DS(on)</sub>	I <sub>OUT</sub>	V <sub>CC</sub>
VN05NSP	60 V	0.18 Ω	13 A	26 V

- OUTPUT CURRENT (CONTINUOUS):  
13 A @ T<sub>c</sub>=25°C
- 5 V LOGIC LEVEL COMPATIBLE INPUT
- THERMAL SHUT-DOWN
- UNDER VOLTAGE SHUT-DOWN
- OPEN DRAIN DIAGNOSTIC OUTPUT
- VERY LOW STAND-BY POWER DISSIPATION

### DESCRIPTION

The VN05NSP is a monolithic devices made using STMicroelectronics VIPower Technology, intended for driving resistive or inductive loads with one side grounded.

Built-in thermal shut-down protects the chip from over temperature and short circuit.

The input control is 5V logic level compatible.

The open drain diagnostic output indicates open circuit (no load) and over temperature status.



### BLOCK DIAGRAM

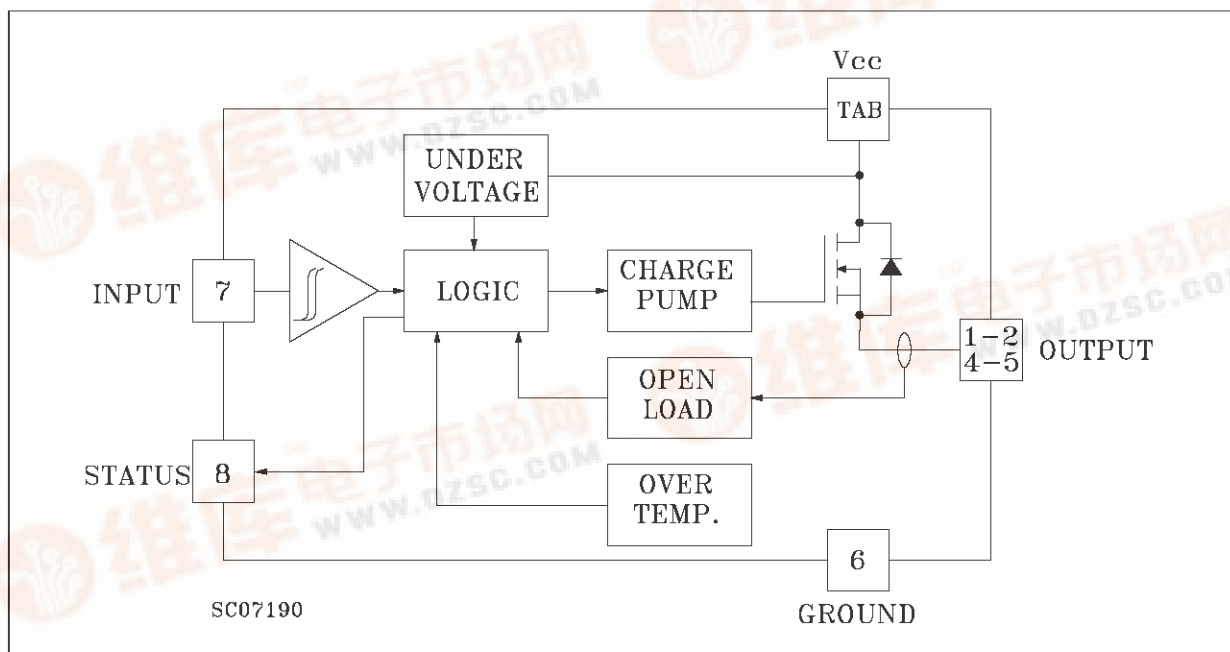

# VN05NSP

## ABSOLUTE MAXIMUM RATING

Symbol	Parameter	Value	Unit
$V_{(BR)DSS}$	Drain-Source Breakdown Voltage	60	V
$I_{OUT}$	Output Current (cont.)	13	A
$I_R$	Reverse Output Current	-13	A
$I_{IN}$	Input Current	$\pm 10$	mA
$-V_{CC}$	Reverse Supply Voltage	-4	V
$I_{STAT}$	Status Current	$\pm 10$	mA
$V_{ESD}$	Electrostatic Discharge (1.5 k $\Omega$ , 100 pF)	2000	V
$P_{tot}$	Power Dissipation at $T_c \leq 25$ °C	56	W
$T_j$	Junction Operating Temperature	-40 to 150	°C
$T_{stg}$	Storage Temperature	-55 to 150	°C

## CONNECTION DIAGRAMS

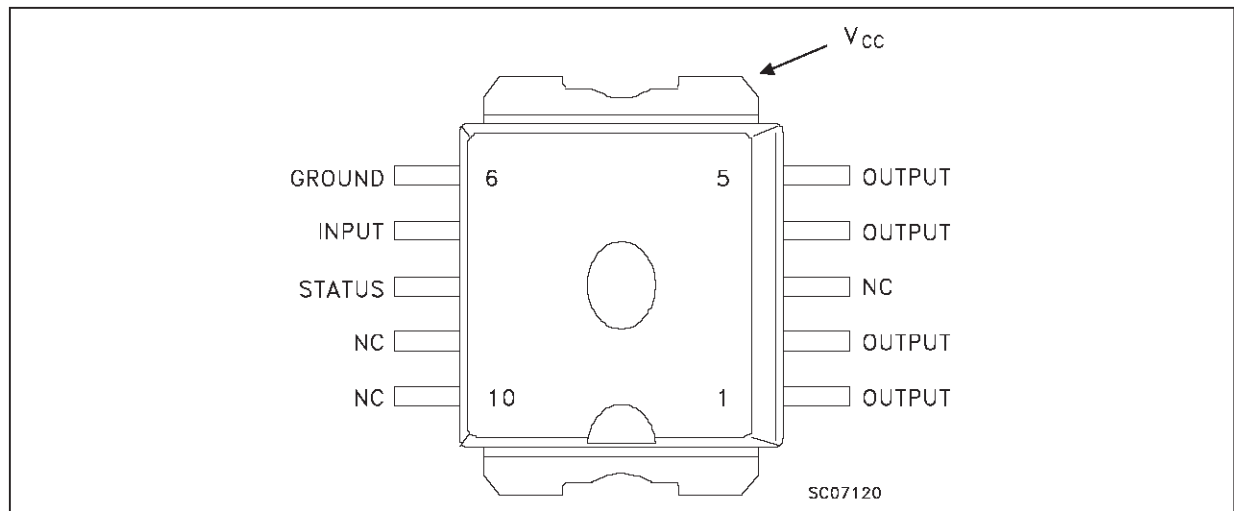

## CURRENT AND VOLTAGE CONVENTIONS

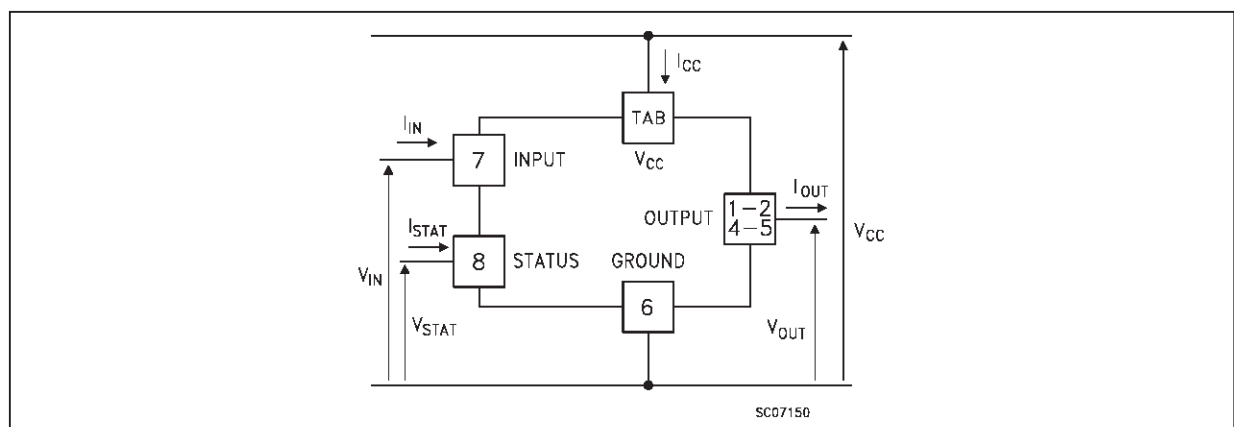

## THERMAL DATA

$R_{thj-case}$	Thermal Resistance Junction-case	Max	2.2	$^{\circ}\text{C}/\text{W}$
$R_{thj-amb}$	Thermal Resistance Junction-ambient (\$)	Max	50	$^{\circ}\text{C}/\text{W}$

(\$) When mounted using minimum recommended pad size on FR-4 board

ELECTRICAL CHARACTERISTICS ( $V_{CC} = 13\text{ V}$ ;  $-40 \leq T_j \leq 125\text{ }^{\circ}\text{C}$  unless otherwise specified)

## POWER

Symbol	Parameter	Test Conditions	Min.	Typ.	Max.	Unit
$V_{CC}$	Supply Voltage		7		26	V
$R_{on}$	On State Resistance	$I_{OUT} = 6\text{ A}$ $I_{OUT} = 6\text{ A}$ $T_j = 25\text{ }^{\circ}\text{C}$			0.36 0.18	$\Omega$ $\Omega$
$I_s$	Supply Current	Off State $T_j \geq 25\text{ }^{\circ}\text{C}$ On State			50 15	$\mu\text{A}$ mA

## SWITCHING

Symbol	Parameter	Test Conditions	Min.	Typ.	Max.	Unit
$t_{d(on)}$	Turn-on Delay Time Of Output Current	$I_{OUT} = 6\text{ A}$ Resistive Load Input Rise Time $< 0.1\text{ }\mu\text{s}$ $T_j = 25\text{ }^{\circ}\text{C}$		15		$\mu\text{s}$
$t_r$	Rise Time Of Output Current	$I_{OUT} = 6\text{ A}$ Resistive Load Input Rise Time $< 0.1\text{ }\mu\text{s}$ $T_j = 25\text{ }^{\circ}\text{C}$		30		$\mu\text{s}$
$t_{d(off)}$	Turn-off Delay Time Of Output Current	$I_{OUT} = 6\text{ A}$ Resistive Load Input Rise Time $< 0.1\text{ }\mu\text{s}$ $T_j = 25\text{ }^{\circ}\text{C}$		20		$\mu\text{s}$
$t_f$	Fall Time Of Output Current	$I_{OUT} = 6\text{ A}$ Resistive Load Input Rise Time $< 0.1\text{ }\mu\text{s}$ $T_j = 25\text{ }^{\circ}\text{C}$		10		$\mu\text{s}$
$(di/dt)_{on}$	Turn-on Current Slope	$I_{OUT} = 6\text{ A}$ $I_{OUT} = I_{OV}$			0.5 2	A/ $\mu\text{s}$ A/ $\mu\text{s}$
$(di/dt)_{off}$	Turn-off Current Slope	$I_{OUT} = 6\text{ A}$ $I_{OUT} = I_{OV}$			2 4	A/ $\mu\text{s}$ A/ $\mu\text{s}$

## LOGIC INPUT

Symbol	Parameter	Test Conditions	Min.	Typ.	Max.	Unit
$V_{IL}$	Input Low Level Voltage				0.8	V
$V_{IH}$	Input High Level Voltage		2		(*)	V
$V_{I(hyst.)}$	Input Hysteresis Voltage			0.5		V
$I_{IN}$	Input Current	$V_{IN} = 5\text{ V}$		250	500	$\mu\text{A}$
$V_{ICL}$	Input Clamp Voltage	$I_{IN} = 10\text{ mA}$ $I_{IN} = -10\text{ mA}$		6 -0.7		V V

## PROTECTIONS AND DIAGNOSTICS

Symbol	Parameter	Test Conditions	Min.	Typ.	Max.	Unit
$V_{STAT} (\bullet)$	Status Voltage Output Low	$I_{STAT} = 1.6\text{ mA}$			0.4	V
$V_{USD}$	Under Voltage Shut Down			6.5		V

**ELECTRICAL CHARACTERISTICS** (continued)

## PROTECTION AND DIAGNOSTICS (continued)

Symbol	Parameter	Test Conditions	Min.	Typ.	Max.	Unit
V <sub>SCL</sub> (●)	Status Clamp Voltage	I <sub>STAT</sub> = 10 mA I <sub>STAT</sub> = -10 mA		6 -0.7		V V
t <sub>SC</sub>	Switch-off Time in Short Circuit Condition at Start-Up	R <sub>LOAD</sub> < 10 mΩ T <sub>c</sub> = 25 °C		1.5	5	ms
I <sub>OV</sub>	Over Current	R <sub>LOAD</sub> < 10 mΩ -40 T <sub>c</sub> 125 °C			60	A
I <sub>AV</sub>	Average Current in Short Circuit	R <sub>LOAD</sub> < 10 mΩ T <sub>c</sub> = 85 °C		1.4		A
I <sub>OL</sub>	Open Load Current Level		5		180	mA
T <sub>TSD</sub>	Thermal Shut-down Temperature		140			°C
T <sub>R</sub>	Reset Temperature		125			°C

(\*) The V<sub>IH</sub> is internally clamped at 6V about. It is possible to connect this pin to an higher voltage via an external resistor calculated to not exceed 10 mA at the input pin.

(●) Status determination > 100 μs after the switching edge.

**FUNCTIONAL DESCRIPTION**

The device has a diagnostic output which indicates open circuit (no load) and over temperature conditions. The output signals are processed by internal logic.

To protect the device against short circuit and over-current condition, the thermal protection turns the integrated Power MOS off at a minimum junction temperature of 140 °C. When the temperature returns to about 125 °C the switch is automatically turned on again.

In short circuit conditions the protection reacts with virtually no delay, the sensor being located in the region of the die where the heat is generated.

**PROTECTING THE DEVICE AGAINST REVERSE BATTERY**

The simplest way to protect the device against a continuous reverse battery voltage (-26V) is to insert a Schottky diode between pin 1 (GND) and ground, as shown in the typical application circuit (fig. 3).

The consequences of the voltage drop across this diode are as follows:

- If the input is pulled to power GND, a negative voltage of -V<sub>F</sub> is seen by the device. (V<sub>IL</sub>, V<sub>IH</sub> thresholds and V<sub>STAT</sub> are increased by V<sub>F</sub> with respect to power GND).

The undervoltage shutdown level is increased by V<sub>F</sub>.

If there is no need for the control unit to handle external analog signals referred to the power GND, the best approach is to connect the reference potential of the control unit to node [1] (see application circuit infig. 4), which becomes the common signal GND for the whole control board.

In this way no shift of V<sub>IH</sub>, V<sub>IL</sub> and V<sub>STAT</sub> takes place and no negative voltage appears on the INPUT pin; this solution allows the use of a standard diode, with a breakdown voltage able to handle any ISO normalized negative pulses that occurs in the automotive environment.

**TRUTH TABLE**

	INPUT	OUTPUT	DIAGNOSTIC
Normal Operation	L H	L H	H H
Open Circuit (No Load)	H	H	L
Over-temperature	H	L	L
Under-voltage	X	L	H

**Figure 1: Waveforms**

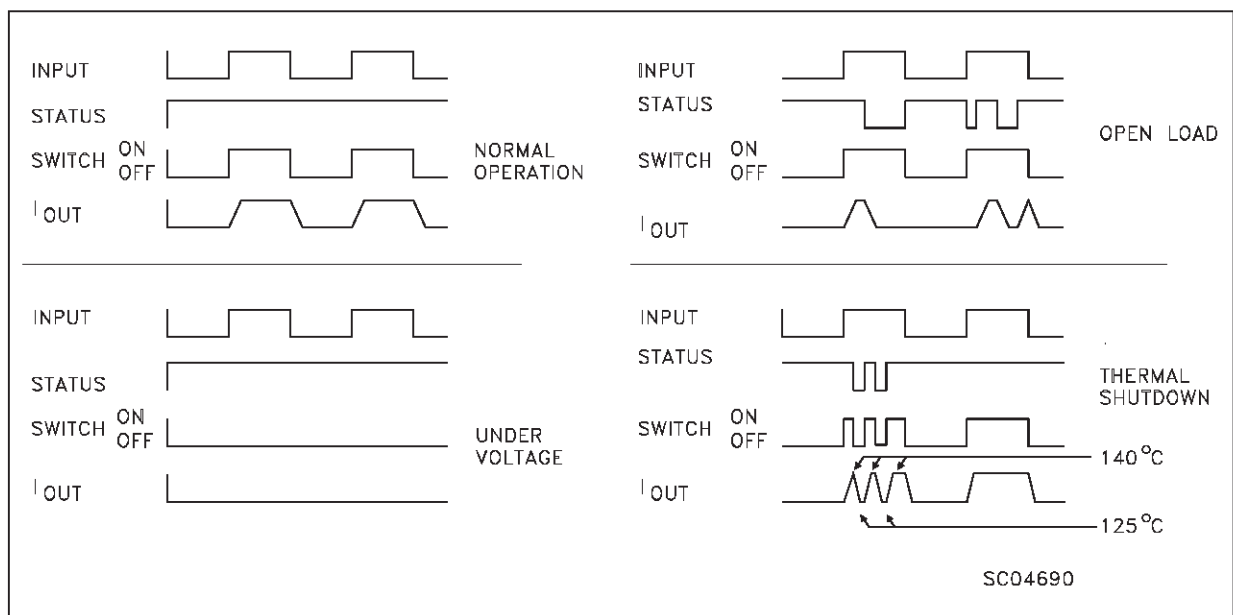

**Figure 2: Over Current Test Circuit**

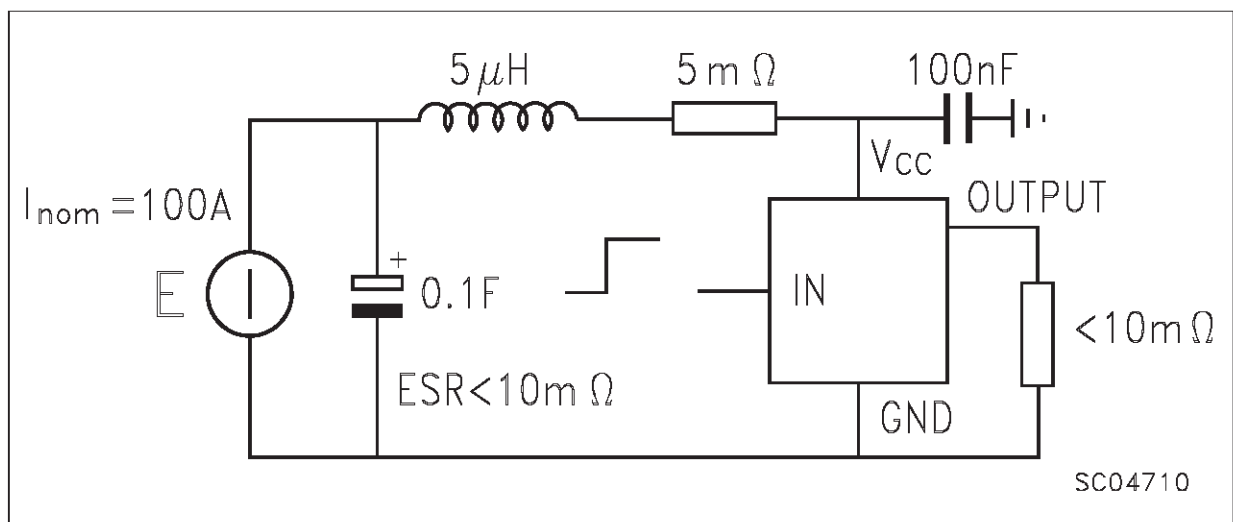

**Figure 3:** Typical Application Circuit With A Schottky Diode For Reverse Supply Protection

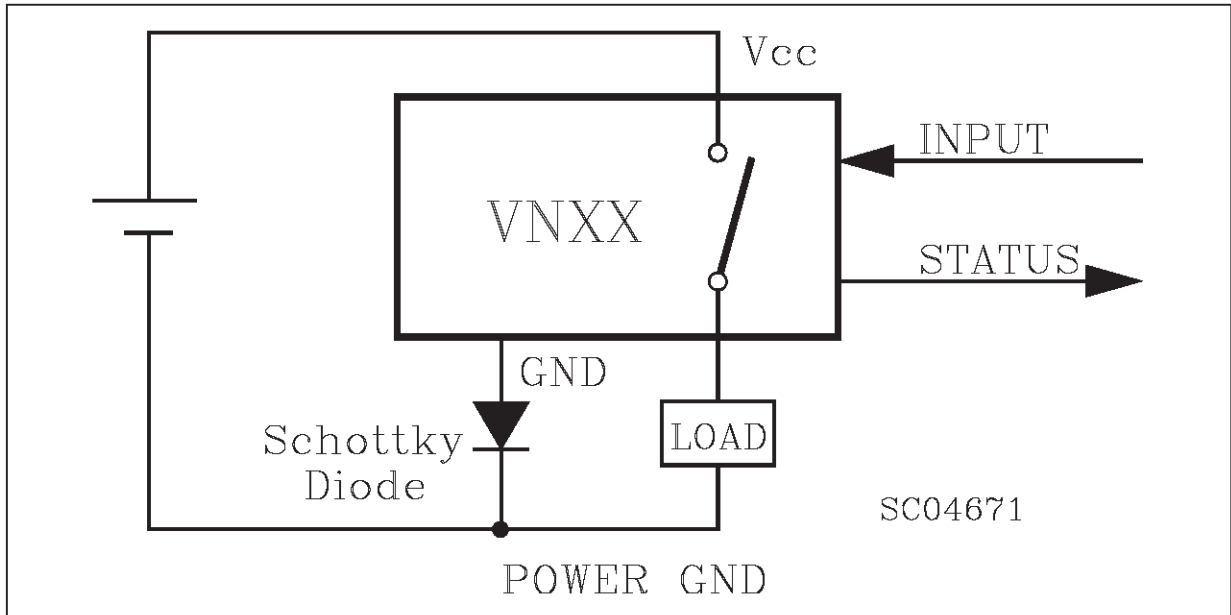

**Figure 4:** Typical Application Circuit With Separate Signal Ground

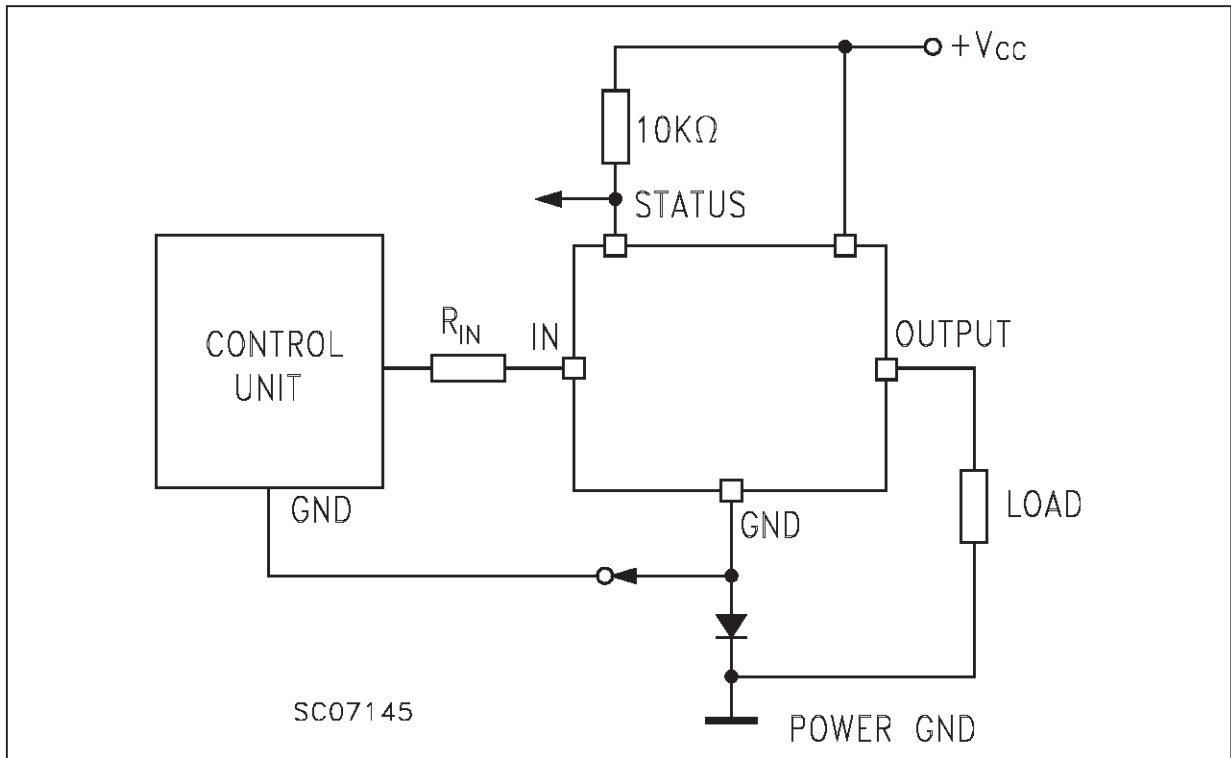

$R_{DS(on)}$  vs Junction Temperature

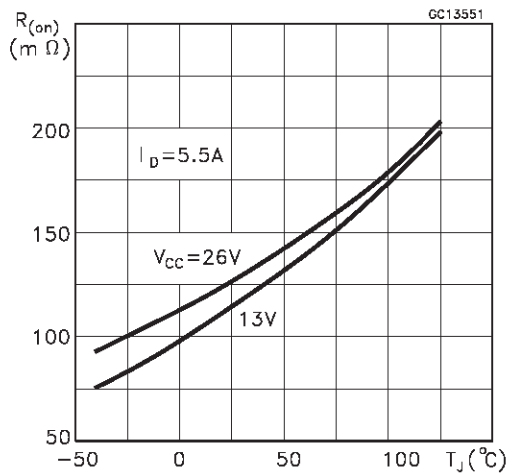

$R_{DS(on)}$  Vs Supply Voltage

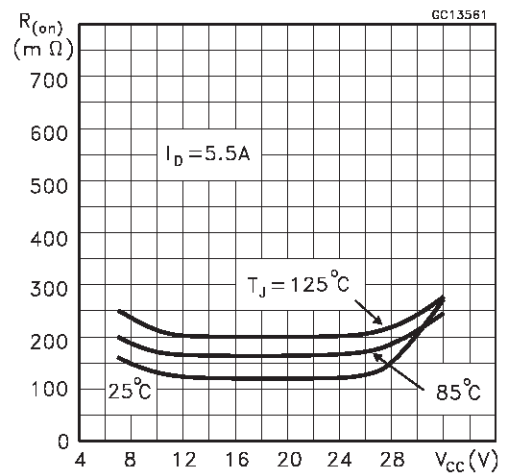

$R_{DS(on)}$  Vs Output Current

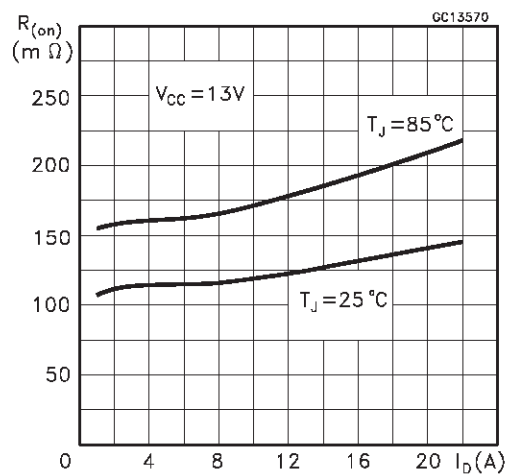

Input Voltage vs Junction Temperature

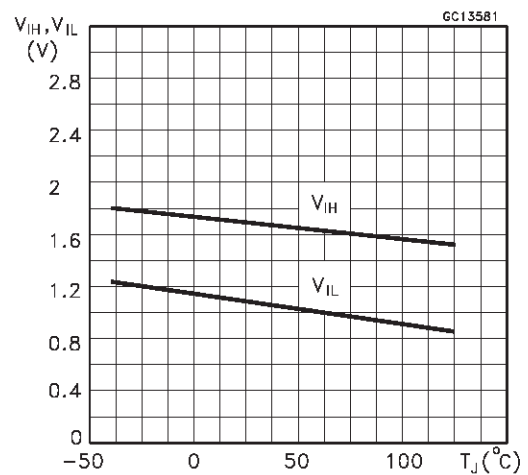

Output Current Derating

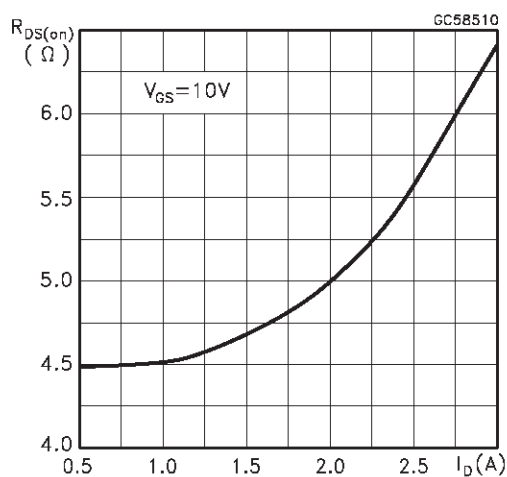

Open Load vs Junction Temperature

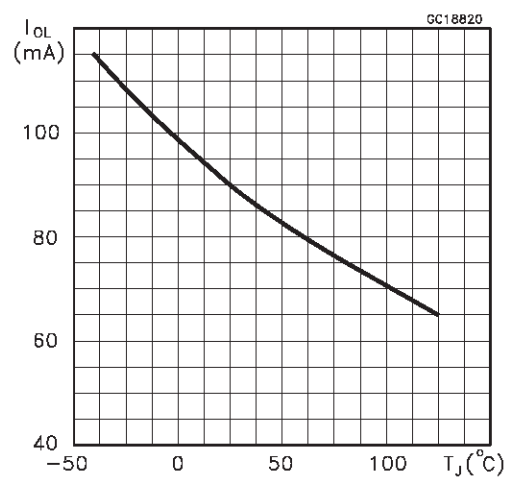

**PowerSO-10 MECHANICAL DATA**

DIM.	mm			inch		
	MIN.	TYP.	MAX.	MIN.	TYP.	MAX.
A	3.35		3.65	0.132		0.144
A1	0.00		0.10	0.000		0.004
B	0.40		0.60	0.016		0.024
c	0.35		0.55	0.013		0.022
D	9.40		9.60	0.370		0.378
D1	7.40		7.60	0.291		0.300
E	9.30		9.50	0.366		0.374
E1	7.20		7.40	0.283		0.291
E2	7.20		7.60	0.283		0.300
E3	6.10		6.35	0.240		0.250
E4	5.90		6.10	0.232		0.240
e		1.27			0.050	
F	1.25		1.35	0.049		0.053
H	13.80		14.40	0.543		0.567
h		0.50			0.002	
L	1.20		1.80	0.047		0.071
q		1.70			0.067	
$\alpha$	0°		8°			

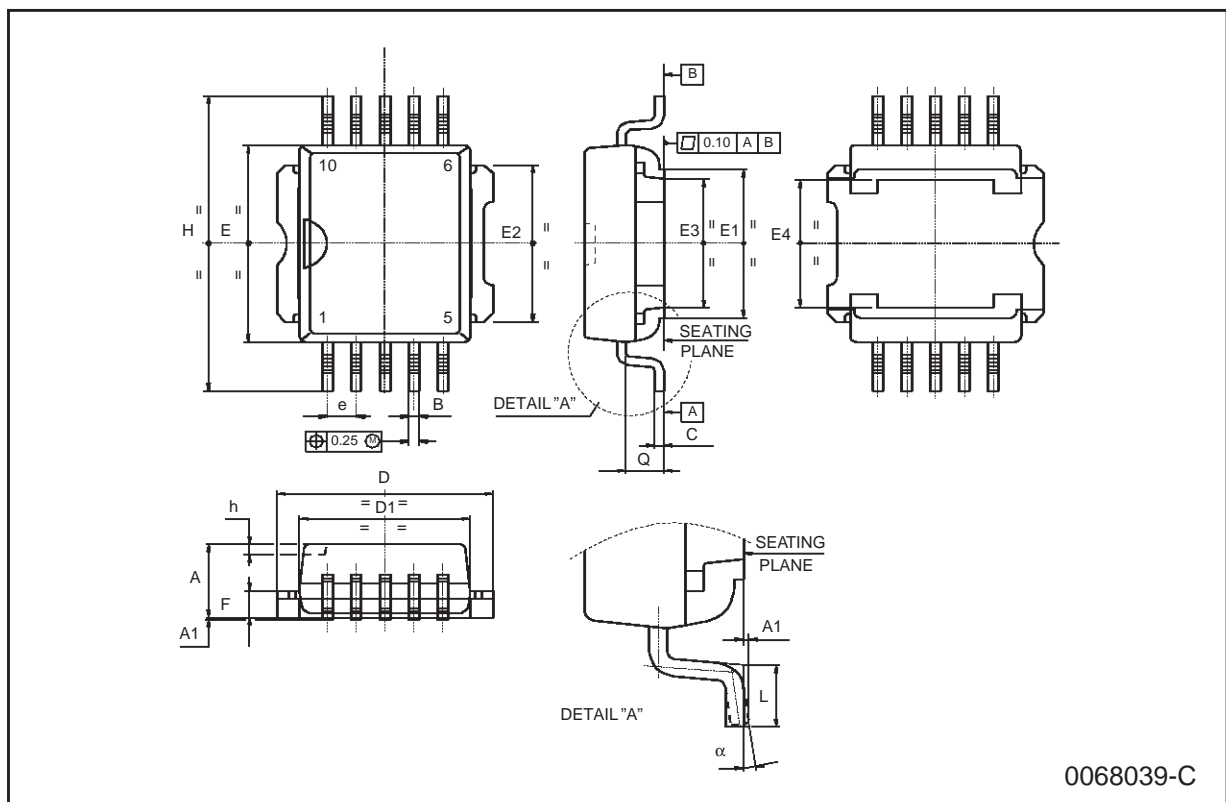

0068039-C

Information furnished is believed to be accurate and reliable. However, STMicroelectronics assumes no responsibility for the consequences of use of such information nor for any infringement of patents or other rights of third parties which may result from its use. No license is granted by implication or otherwise under any patent or patent rights of STMicroelectronics. Specification mentioned in this publication are subject to change without notice. This publication supersedes and replaces all information previously supplied. STMicroelectronics products are not authorized for use as critical components in life support devices or systems without express written approval of STMicroelectronics.

The ST logo is a trademark of STMicroelectronics

© 1998 STMicroelectronics – Printed in Italy – All Rights Reserved  
STMicroelectronics GROUP OF COMPANIES

Australia - Brazil - Canada - China - France - Germany - Italy - Japan - Korea - Malaysia - Malta - Mexico - Morocco - The Netherlands -  
Singapore - Spain - Sweden - Switzerland - Taiwan - Thailand - United Kingdom - U.S.A.