

## 1.2V Low Voltage Operation, 150mA High Speed LDO Voltage Regulator

### GENERAL DESCRIPTION

The XC6224 series is a high speed LDO regulator that features high accurate, low noise, high ripple rejection, low dropout and low power consumption. The series consists of a voltage reference, an error amplifier, a driver transistor, a current limiter, and a phase compensation circuit.

This IC is suitable for a local power supply placed in adjacent to the system logic LSI or others, because of low input voltage operation, using an ultra small package USPN-4B02 (0.75mm x 0.95mm) and stable operation with a small phase compensation capacitor ( $C_L$ ) 0.47  $\mu$ F.

Also, this IC has fast transient response and high ripple rejection (70dB @ 1kHz).

The CE function enables the circuit to be in stand-by mode by inputting low level signal. In the stand-by mode, the series enables the electric charge at the output capacitor  $C_L$  to be discharged via the internal switch, and as a result the  $V_{OUT}$  pin quickly returns to the  $V_{SS}$  level.

The over current protection circuit is integrated and operates when the output current reaches current limit level.

### APPLICATIONS

- Smart phones / Mobile phones
- Digital still cameras
- Mobile devices / terminals
- Bluetooth
- Wireless LAN
- Digital TV tuners

### FEATURES

<b>Maximum Output Current</b>	: 150mA
<b>Operating Voltage Range</b>	: 1.2V ~ 3.6V
<b>High Accuracy</b>	: $\pm 1.5\%$ ( $V_{OUT} = 1.25V \sim 3.0V$ ) $\pm 20mV$ ( $V_{OUT} = 0.8V \sim 1.20V$ )
<b>Low Power Consumption</b>	: 33 $\mu$ A (TYP.)
<b>Stand-by Current</b>	: 0.1 $\mu$ A
<b>High Ripple Rejection</b>	: 70dB@1kHz
<b>Dropout Voltage</b>	: 210mV@150mA ( $V_{OUT}=2.8V$ )
<b>Protection Circuits</b>	: Current Limiter Short Circuit Protection
<b>ON/OFF Control</b>	: Active High $C_L$ Auto Discharge Function
<b>Output Capacitor</b>	: Low ESR Capacitor
<b>Operating Ambient Temperature</b>	: -40 ~ +85
<b>Packages</b>	: USPN-4B02 SSOT-24 SOT-25
<b>Environmentally Friendly</b>	: EU RoHS Compliant, Pb Free

### TYPICAL APPLICATION CIRCUIT

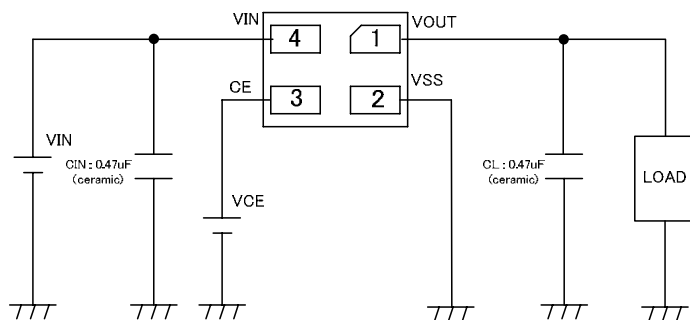

USPN-4B02 0.75mm x 0.95mm size  
(BOTTOM VIEW)

### TYPICAL PERFORMANCE CHARACTERISTICS

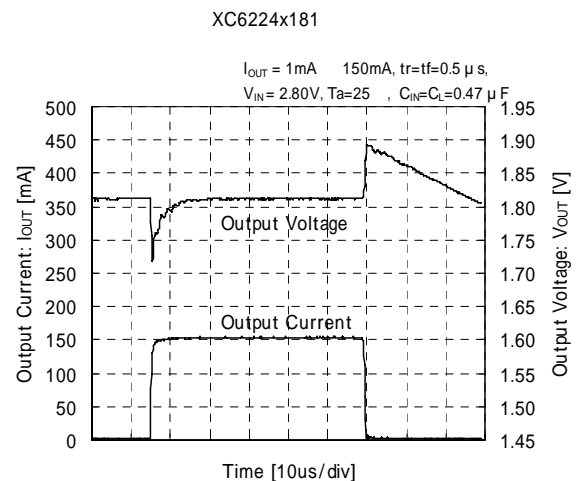

## PIN CONFIGURATION

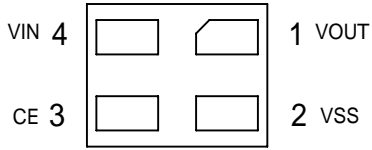

USPN-4B02  
(BOTTOM VIEW)

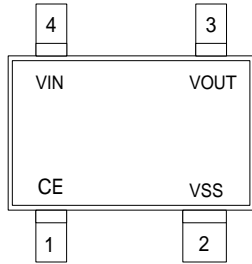

SSOT-24  
(TOP VIEW)

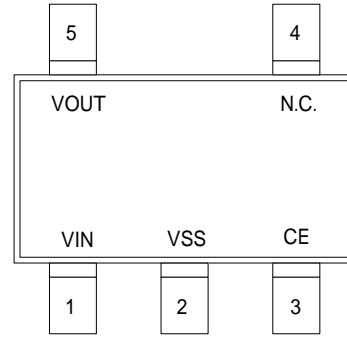

SOT-25  
(TOP VIEW)

## PIN ASSIGNMENT

PIN NUMBER			PIN NAME	FUNCTIONS
USPN-4B02	SSOT-24	SOT-25		
4	4	1	$V_{IN}$	Power Input
1	3	5	$V_{OUT}$	Output
2	2	2	$V_{SS}$	Ground
3	1	3	CE	ON/OFF Control
-	-	4	NC	No Connection

## PIN LOGIC CONDITION

PIN NAME	DESIGNATOR	CONDITIONS
CE	L	0V $V_{CE}$ 0.3V
	H	1.0V $V_{CE}$ 3.6V
	OPEN	$V_{CE}$ =OPEN

## FUNCTION CHART FOR CE PIN

DESIGNATOR	IC OPERATION
H	ON
L	OFF (Stand-by)
OPEN	Undefined state in XC6224A
	OFF(Stand-by) in XC6224B*

H=High Level

L=Low Level

\*An internal pull-down resistor maintains the CE pin voltage to be low.

## PRODUCT CLASSIFICATION

Ordering Information

XC6224 \_\_\_\_\_ - (\*)

DESIGNATOR	ITEM	SYMBOL	DESCRIPTION
	Type of Regulator	A	CE Active High, Without CE pull-down, with C <sub>L</sub> Discharge
		B	CE Active High, With CE pull-down, with C <sub>L</sub> Discharge
	Output Voltage	08 ~ 30	ex.) 2.5V      =2,      =5
	Output Voltage (The 2 <sup>nd</sup> Decimal Place)	1	{x.x0V} (the 2 <sup>nd</sup> decimal place is "0")
		B	{x.x5V} (the 2 <sup>nd</sup> decimal place is "5")
-	Packages (Order Unit)	7R-G	USPN-4B02 (5,000/Reel)
		MR-G	SOT-25 (3,000/Reel)
		NR-G	SSOT-24 (3,000/Reel)

(\*) The "-G" suffix denotes Halogen and Antimony free as well as being fully EU RoHS compliant.

## BLOCK DIAGRAMS

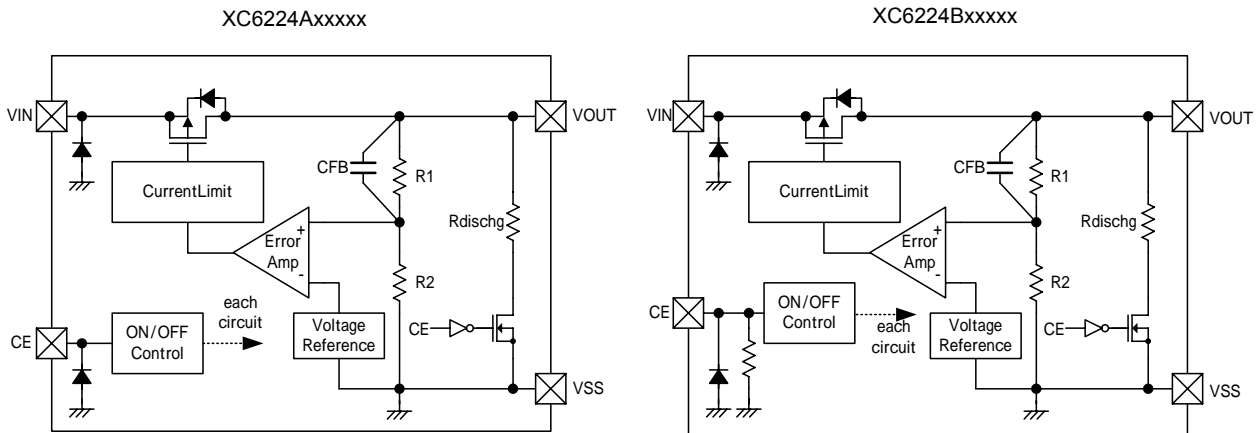

## ABSOLUTE MAXIMUM RATINGS

PARAMETER	SYMBOL	RATINGS	UNITS	
Input Voltage	$V_{IN}$	$V_{SS}-0.3 \sim +4.6$	V	
Output Current	$I_{OUT}$	180 <sup>(*1)</sup>	mA	
Output Voltage	$V_{OUT}$	$V_{SS}-0.3 \sim V_{IN}+0.3$	V	
CE Input Voltage	$V_{CE}$	$V_{SS}-0.3 \sim 4.6$	V	
Power Dissipation	USPN-4B02	100	mW	
		550 (PCB mounted) <sup>(*2)</sup>		
		SSOT24		150
				500 (PCB mounted) <sup>(*2)</sup>
		SOT-25		250
600 (PCB mounted) <sup>(*2)</sup>				
Operating Ambient Temperature	$T_{opr}$	$-40 \sim +85$		
Storage Temperature	$T_{stg}$	$-55 \sim +125$		

\*1: Please use within the range of  $I_{OUT} \cdot Pd / (V_{IN} - V_{OUT})$

\*2: This is a reference data taken by using the test board. Please refer to page 21 ~ 23 for details.

## ELECTRICAL CHARACTERISTICS

XC6224Axxxxx

Ta=25

PARAMETER	SYMBOL	CONDITIONS	MIN.	TYP.	MAX.	UNITS	CURCUITS
Output Voltage	V <sub>OUT(E)</sub> <sup>(3)</sup>	V <sub>OUT(T)</sub> 1.25V V <sub>CE</sub> =V <sub>IN</sub> , I <sub>OUT</sub> =10mA	V <sub>OUT(T)</sub> ×0.985 <sup>(2)</sup>	V <sub>OUT(T)</sub> <sup>(2)</sup>	V <sub>OUT(T)</sub> ×1.015 <sup>(2)</sup>	V	
		V <sub>OUT(T)</sub> 1.2V V <sub>CE</sub> =V <sub>IN</sub> , I <sub>OUT</sub> =10mA	-20mV <sup>(7)</sup>	V <sub>OUT(T)</sub> <sup>(2)</sup>	+20mV <sup>(7)</sup>		
Maximum Output Current	I <sub>OUTMAX</sub>	V <sub>CE</sub> =V <sub>IN</sub>	150	-	-	mA	
Load Regulation	ΔV <sub>OUT</sub>	V <sub>CE</sub> =V <sub>IN</sub> 0.1mA I <sub>OUT</sub> 150mA	-	5	20	mV	
Dropout Voltage <sup>(4)</sup>	V <sub>dif</sub>	I <sub>OUT</sub> =150mA V <sub>CE</sub> =V <sub>IN</sub> , V <sub>IN</sub> =V <sub>OUT(E)</sub> ×0.98 <sup>(3)</sup>	E-1			mV	
Supply Current	I <sub>DD</sub>	V <sub>CE</sub> =V <sub>IN</sub> , I <sub>OUT</sub> =0mA	-	33	77	μA	
Stand-by Current	I <sub>STBY</sub>	V <sub>CE</sub> =V <sub>SS</sub>	-	0.01	0.4	μA	
Line Regulation	ΔV <sub>OUT</sub> / (ΔV <sub>IN</sub> ·V <sub>OUT</sub> )	V <sub>OUT(T)</sub> 1.10V V <sub>OUT(T)</sub> +0.5V V <sub>IN</sub> 3.6V V <sub>CE</sub> =V <sub>IN</sub> , I <sub>OUT</sub> =10mA <sup>(2)</sup>	-	0.04	0.37	%V	
		V <sub>OUT(T)</sub> 1.05V 1.6V V <sub>IN</sub> 3.6V V <sub>CE</sub> =V <sub>IN</sub> , I <sub>OUT</sub> =10mA <sup>(2)</sup>					
Input Voltage	V <sub>IN</sub>		1.2	-	3.6	V	
Output Voltage Temperature Characteristics	ΔV <sub>OUT</sub> / (ΔTa·V <sub>OUT</sub> )	V <sub>CE</sub> =V <sub>IN</sub> , I <sub>OUT</sub> =30mA <sup>(1)</sup> -40 Ta 85	-	± 100	-	ppm/	
Power Supply Rejection Ratio	PSRR	V <sub>CE</sub> =V <sub>IN</sub> · When 0.80V V <sub>OUT(T)</sub> 2.60V, V <sub>IN</sub> =3.0V + 0.5Vp-pAC · 2.65V V <sub>OUT(T)</sub> 3.00V V <sub>IN</sub> =3.3V+0.25Vp-pAC I <sub>OUT</sub> =30mA, f=1kHz <sup>(2)</sup>	-	70	-	dB	
Current Limit	I <sub>LIM</sub>	V <sub>CE</sub> =V <sub>IN</sub>	150	250	-	mA	
Short Current	I <sub>SHORT</sub>	V <sub>CE</sub> =V <sub>IN</sub> , V <sub>OUT</sub> is connected to V <sub>SS</sub>	-	35	-	mA	
CE High Level Voltage	V <sub>CEH</sub>		1.0	-	3.6	V	
CE Low Level Voltage	V <sub>CEL</sub>		-	-	0.3	V	
CE High Level Current	I <sub>CEH</sub>	V <sub>CE</sub> =V <sub>IN</sub> A Type	-0.1	0	0.1	μA	
CE High Level Current	I <sub>CEL</sub>	V <sub>CE</sub> =V <sub>SS</sub>	-0.1	0	0.1	μA	
C <sub>L</sub> Discharge Resistance	R <sub>DCHG</sub>	V <sub>IN</sub> =3.6V, V <sub>CE</sub> =V <sub>SS</sub>	-	450	-	Ω	

**NOTE:**

\*1: Unless otherwise specified, input voltage conditions are;

0.80V V<sub>OUT(T)</sub> 2.60V : {V<sub>IN</sub>=V<sub>OUT(T)</sub>+1.0V}

2.65V V<sub>OUT(T)</sub> 2.80V : {V<sub>IN</sub>=3.3V}

2.85V V<sub>OUT(T)</sub> 3.00V : {V<sub>IN</sub>=3.5V}

\*2: V<sub>OUT(T)</sub>: Nominal output voltage

\*3: V<sub>OUT(E)</sub>: Effective output voltage

This output voltages are measured at the constant current when the input voltages are stable as Note 1.

\*4: V<sub>dif</sub> = {V<sub>IN1</sub><sup>(5)</sup> - V<sub>OUT1</sub><sup>(6)</sup>}

\*5: V<sub>IN1</sub>=The input voltage when V<sub>OUT1</sub> appears as input voltage is gradually decreased.

\*6: V<sub>OUT1</sub>=A voltage equal to 98% of the output voltage whenever an amply stabilized I<sub>OUT</sub> {V<sub>OUT(T)</sub>+1.0V} is input

\*7: V<sub>OUT(T)</sub>±20mV is the specification value of output voltage where V<sub>OUT(T)</sub> 1.20V

## ELECTRICAL CHARACTERISTICS (Continued)

XC6224Bxxxxx

Ta=25

PARAMETER	SYMBOL	CONDITIONS	MIN.	TYP.	MAX.	UNITS	CIRCUITS
Output Voltage	$V_{OUT(E)}$ <sup>(3)</sup>	$V_{OUT(T)}$ 1.25V $V_{CE}=V_{IN}$ , $I_{OUT}=10mA$	$V_{OUT(T)} \times 0.985$ <sup>(2)</sup>	$V_{OUT(T)}$ <sup>(2)</sup>	$V_{OUT(T)} \times 1.015$ <sup>(2)</sup>	V	
		$V_{OUT(T)}$ 1.2V, $V_{IN}=2.5V$ $V_{CE}=V_{IN}$ , $I_{OUT}=10mA$	-20mV <sup>(7)</sup>	$V_{OUT(T)}$ <sup>(2)</sup>	+20mV <sup>(7)</sup>		
Maximum Output Current	$I_{OUTMAX}$	$V_{CE}=V_{IN}$ <sup>(1)</sup>	150	-	-	mA	
Load Regulation	$\Delta V_{OUT}$	$V_{CE}=V_{IN}$ <sup>(1)</sup> 0.1mA $I_{OUT}$ 150mA	-	5	20	mV	
Dropout Voltage <sup>(4)</sup>	Vdif	$I_{OUT}=150mA$ , $V_{CE}=V_{IN}$ $V_{IN}=V_{OUT(E)} \times 0.98$ <sup>(3)</sup>	E-1			mV	
Supply Current	$I_{DD}$	$V_{CE}=V_{IN}$ <sup>(1)</sup> $I_{OUT}=0mA$	-	33	77	$\mu A$	
Stand-by Current	$I_{STBY}$	$V_{CE}=V_{SS}$	-	0.01	0.4	$\mu A$	
Line Regulation	$\frac{\Delta V_{OUT}}{(\Delta V_{IN} \cdot V_{OUT})}$	$V_{OUT(T)}$ 1.10V $V_{OUT(T)}+0.5V$ $V_{IN}$ 3.6V $V_{CE}=V_{IN}$ , $I_{OUT}=10mA$ <sup>(2)</sup>	-	0.04	0.37	%V	
		$V_{OUT(T)}$ 1.05V 1.6V $V_{IN}$ 3.6V $V_{CE}=V_{IN}$ , $I_{OUT}=10mA$ <sup>(2)</sup>					
Input Voltage	$V_{IN}$		1.2	-	3.6	V	
Output Voltage Temperature Characteristics	$\frac{\Delta V_{OUT}}{(\Delta Ta \cdot V_{OUT})}$	$V_{CE}=V_{IN}$ , $I_{OUT}=30mA$ <sup>(1)</sup> -40 $Ta$ 85	-	$\pm 100$	-	ppm/	
Power Supply Rejection Ratio	PSRR	$V_{CE}=V_{IN}$ · When 0.80V $V_{OUT(T)}$ 2.60V $V_{IN}=3.0V + 0.5Vp-pAC$ · 2.65V $V_{OUT(T)}$ 3.00V $V_{IN}=3.3V + 0.25Vp-pAC$ $I_{OUT}=30mA$ , $f=1kHz$ <sup>(2)</sup>	-	70	-	dB	
Current Limit	$I_{LIM}$	$V_{CE}=V_{IN}$	150	250	-	mA	
Short Current	$I_{SHORT}$	$V_{CE}=V_{IN}$ , $V_{OUT}$ is connected to $V_{SS}$	-	35	-	mA	
CE High Level Voltage	$V_{CEH}$		1.0	-	3.6	V	
CE Low Level Voltage	$V_{CEL}$		-	-	0.3	V	
CE High Level Current	$I_{CEH}$	$V_{CE}=V_{IN}$ B Type	-	5.5	13.0	$\mu A$	
CE High Level Current	$I_{CEL}$	$V_{CE}=V_{SS}$	-0.1	0	0.1	$\mu A$	
$C_L$ Discharge Resistance	$R_{DCHG}$	$V_{IN}=3.6V$ , $V_{CE}=V_{SS}$	-	450	-	$\Omega$	

**NOTE:**

\*1: Unless otherwise specified, input voltage conditions are;

0.80V  $V_{OUT(T)}$  2.60V :  $\{V_{IN}=V_{OUT(T)}+1.0V\}$

2.65V  $V_{OUT(T)}$  2.80V :  $\{V_{IN}=3.3V\}$

2.85V  $V_{OUT(T)}$  3.00V :  $\{V_{IN}=3.5V\}$

\*2:  $V_{OUT(T)}$ : Nominal output voltage

\*3:  $V_{OUT(E)}$ : Effective output voltage

This output voltages are measured at the constant current when the input voltages are stable as Note 1.

\*4:  $V_{dif} = \{V_{IN1}^{(5)} - V_{OUT1}^{(6)}\}$

\*5:  $V_{IN1}$ =The input voltage when  $V_{OUT1}$  appears as input voltage is gradually decreased.

\*6:  $V_{OUT1}$ =A voltage equal to 98% of the output voltage whenever an amply stabilized  $I_{OUT}$   $\{V_{OUT(T)}+1.0V\}$  is input

\*7:  $V_{OUT(T)} \pm 20mV$  is the specification value of output voltage where  $V_{OUT(T)}$  1.20V.

## ELECTRICAL CHARACTERISTICS (Continued)

Voltage Table

NOMINAL OUTPUT VOLTAGE (V)	OUTPUT VOLTAGE <sup>(*)</sup> (V)		DROPOUT VOLTAGE (E-1) (mV)	
	V <sub>OUT(E)</sub>		V <sub>dif</sub>	
V <sub>OUT(T)</sub>	MIN.	MAX.	TYP.	MAX.
0.80	0.7800	0.8200	-	-
0.85	0.8300	0.8700	-	-
0.90	0.8800	0.9200	-	-
0.95	0.9300	0.9700	-	-
1.00	0.9800	1.0200	-	-
1.05	1.0300	1.0700	-	-
1.10	1.0800	1.1200	-	-
1.15	1.1300	1.1700	-	-
1.20	1.1800	1.2200	400	500
1.25	1.2313	1.2687		
1.30	1.2805	1.3195		
1.35	1.3298	1.3702		
1.40	1.3790	1.4210		
1.45	1.4283	1.4717		
1.50	1.4775	1.5225		
1.55	1.5268	1.5732		
1.60	1.5760	1.6240		
1.65	1.6253	1.6747		
1.70	1.6745	1.7255		
1.75	1.7238	1.7762		
1.80	1.7730	1.8270	300	430
1.85	1.8223	1.8777		
1.90	1.8715	1.9285		
1.95	1.9208	1.9792		
2.00	1.9700	2.0300		
2.05	2.0193	2.0807		
2.10	2.0685	2.1315		
2.15	2.1178	2.1822		
2.20	2.1670	2.2330		
2.25	2.2163	2.2837		
2.30	2.2655	2.3345		
2.35	2.3148	2.3852		
2.40	2.3640	2.4360		
2.45	2.4133	2.4867		
2.50	2.4625	2.5375	210	410
2.55	2.5118	2.5882		
2.60	2.5610	2.6390		
2.65	2.6103	2.6897		
2.70	2.6595	2.7405		
2.75	2.7088	2.7912		
2.80	2.7580	2.8420		
2.85	2.8073	2.8927		
2.90	2.8565	2.9435		
2.95	2.9058	2.9942		
3.00	2.9550	3.0450		

(\*)1) When V<sub>OUT(T)</sub> 1.20V, the output voltage accuracy is ±20mV.  
When V<sub>OUT(T)</sub> 1.25V, the output voltage accuracy is ±1.5%.

## OPERATIONAL EXPLANATION

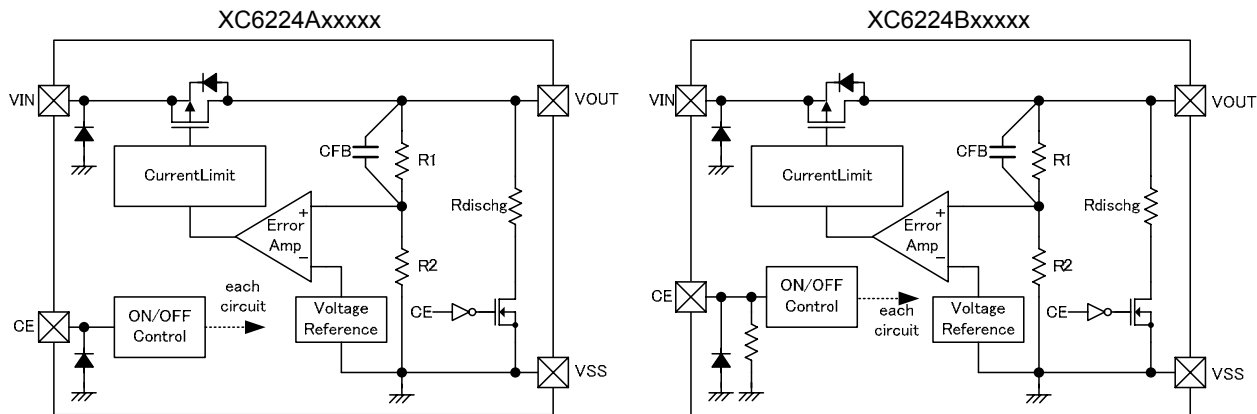

The voltage divided by resistors R1 & R2 is compared with the internal reference voltage by the error amplifier. The P-channel MOSFET which is connected to the V<sub>OUT</sub> pin is then driven by the subsequent output signal. The output voltage at the V<sub>OUT</sub> pin is controlled and stabilized by a system of negative feedback. The current limit circuit and short circuit protection operate in relation to the level of output current. Further, the IC's internal circuitry can be shutdown via the CE pin signal.

### <Low ESR Capacitor>

The XC6224 needs an output capacitor C<sub>L</sub> and a built-in phase compensation circuit for phase compensation. In order to ensure the stable phase compensation, please place an output capacitor C<sub>L</sub> of 0.47 μF or bigger at the V<sub>OUT</sub> pin as close as possible. For a stable power input, please connect an input capacitor C<sub>IN</sub> of 0.47 μF between the V<sub>IN</sub> pin and the V<sub>SS</sub> pin.

### <Current Limiter, Short-Circuit Protection>

The protection circuit operates as a combination of an output current limiter and fold-back short circuit protection. When load current reaches the current limit level, the output voltage drops. As a result, the load current starts to reduce with showing fold-back curve. The output current finally falls at the level of 35mA when the output pin is short-circuited.

### <CE Pin>

The IC's internal circuitry can be shutdown via the signal from the CE pin. In shutdown mode, output at the V<sub>OUT</sub> pin will be pulled down to the V<sub>SS</sub> level in the XC6224B series. When the CE pin is open, the output voltage becomes undefined state in the XC6224A series because of a high active and no pull-down. Although the CE pin is equal to CMOS input configuration, the CE pin input current which flows into a pull-down resistor will increase in the XC6224B series

## NOTES ON USE

1. For temporary, transitional voltage drop or voltage rising phenomenon, the IC is liable to malfunction should the ratings be exceeded.
2. Torex places an importance on improving our products and its reliability.  
However, by any possibility, we would request user fail-safe design and post-aging treatment on system or equipment.
3. Where wiring impedance is high, operations may become unstable due to the noise and/or phase lag depending on output current. Please strengthen V<sub>IN</sub> and V<sub>SS</sub> wiring in particular.
4. The input capacitor C<sub>IN</sub> and the output capacitor C<sub>L</sub> should be placed to the IC as close as possible with a shorter wiring.



## TEST CIRCUITS

Circuit

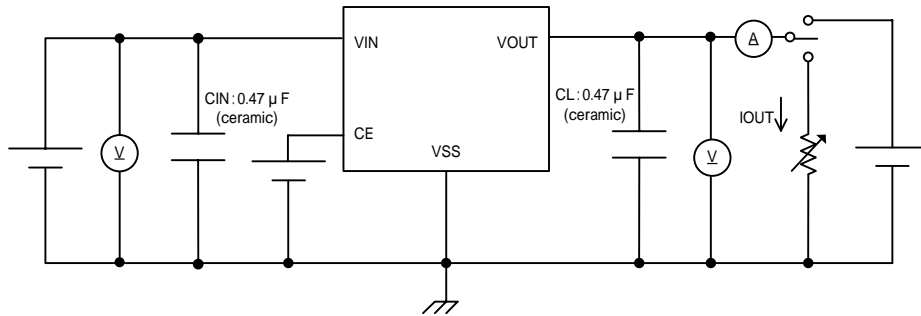

Circuit

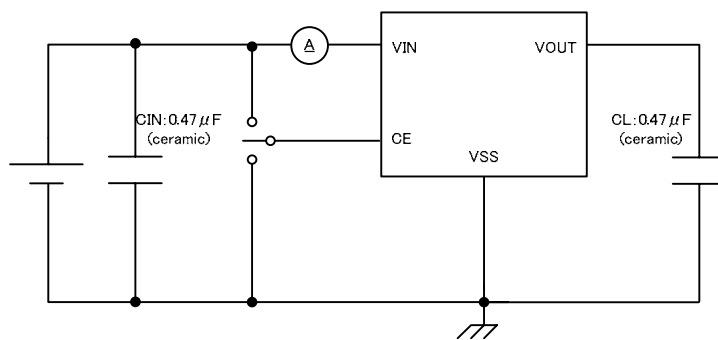

Circuit

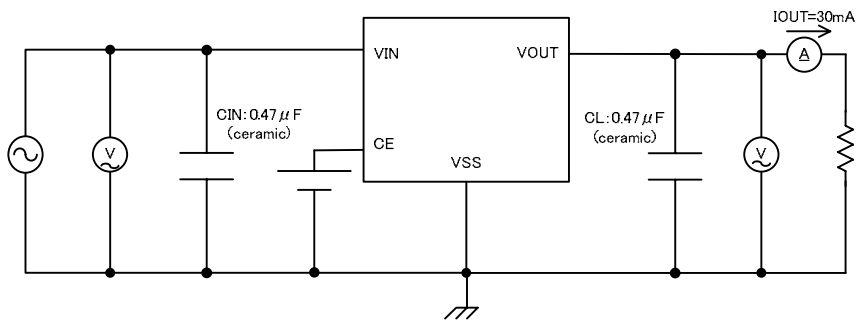

Circuit

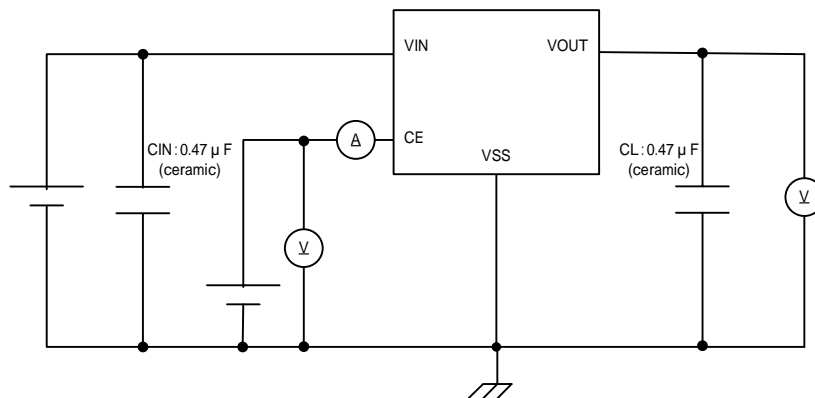

## TYPICAL PERFORMANCE CHARACTERISTICS

### (1) Output Voltage vs. Output Current

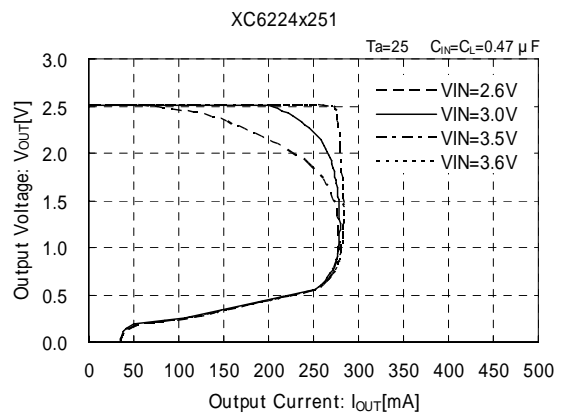
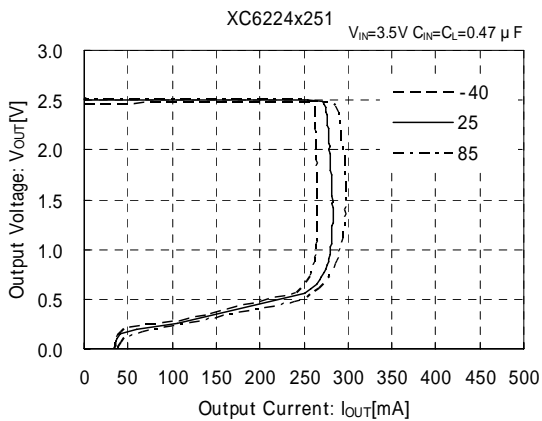
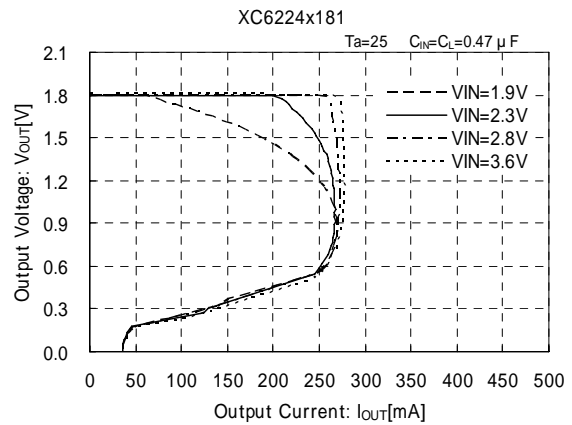
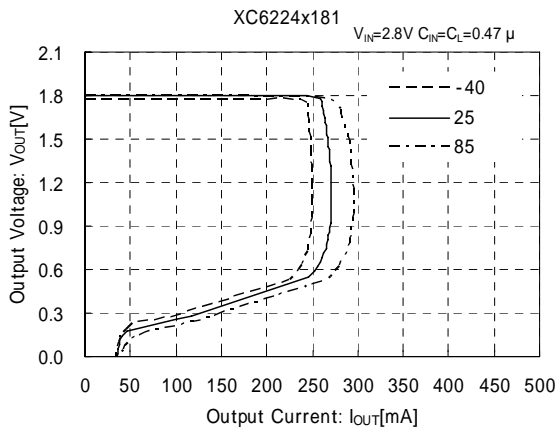
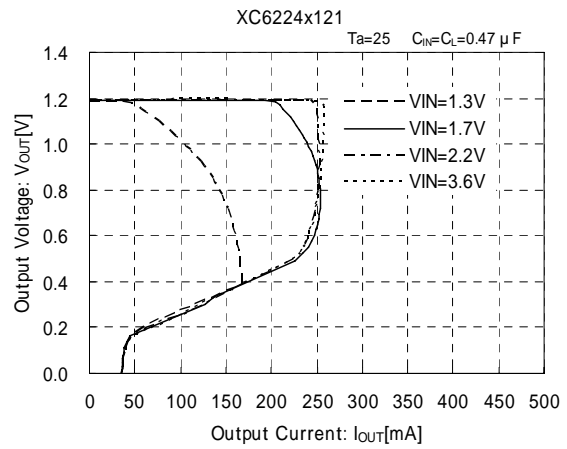
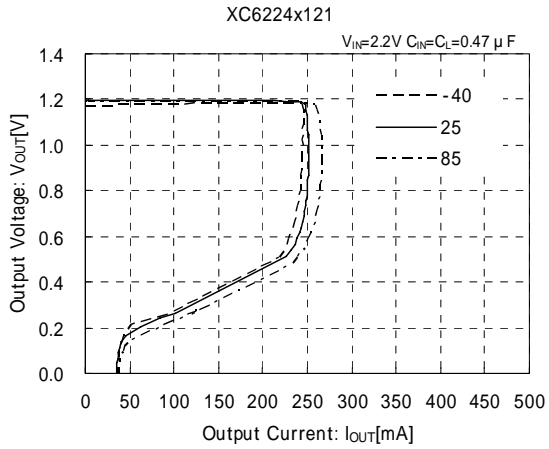

## TYPICAL PERFORMANCE CHARACTERISTICS (Continued)

### (2) Output Voltage vs. Input Voltage

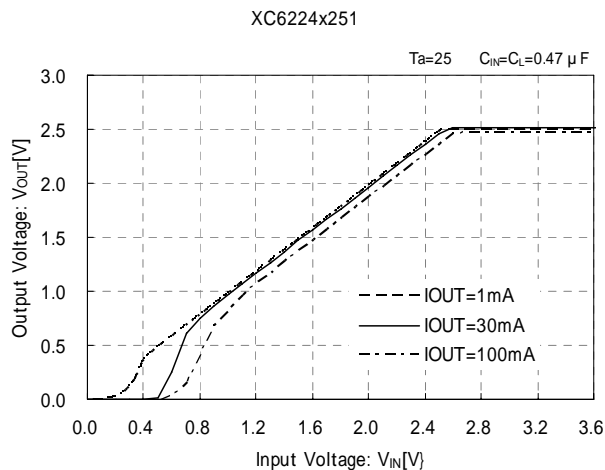
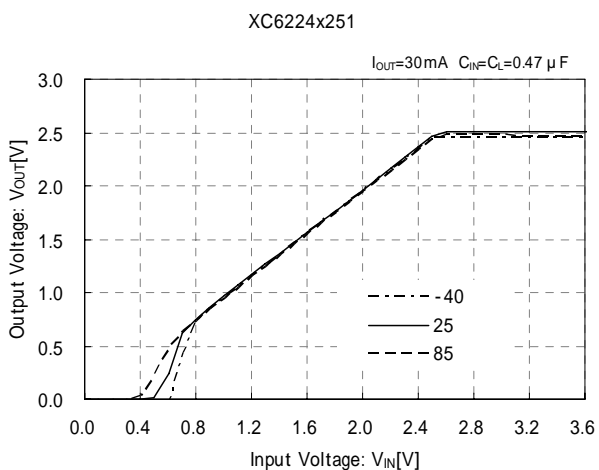
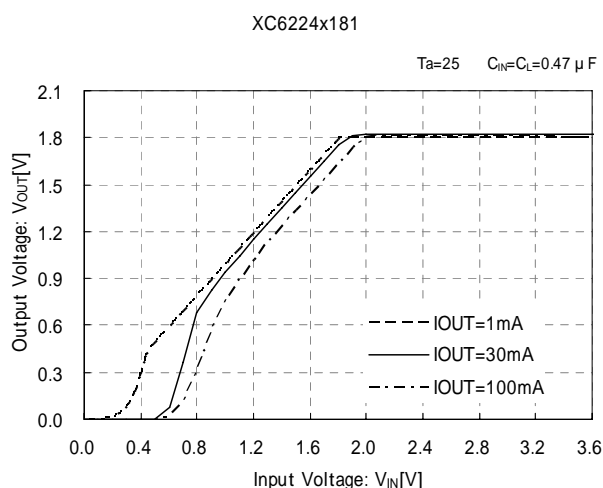
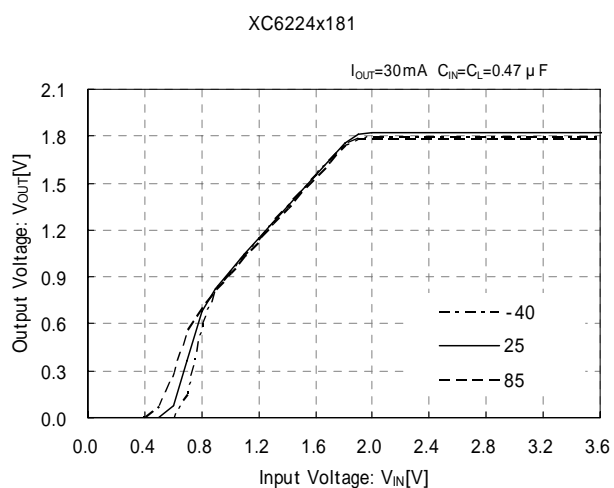
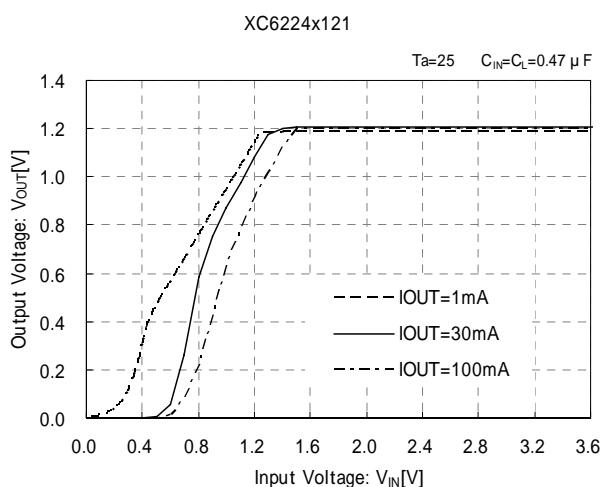
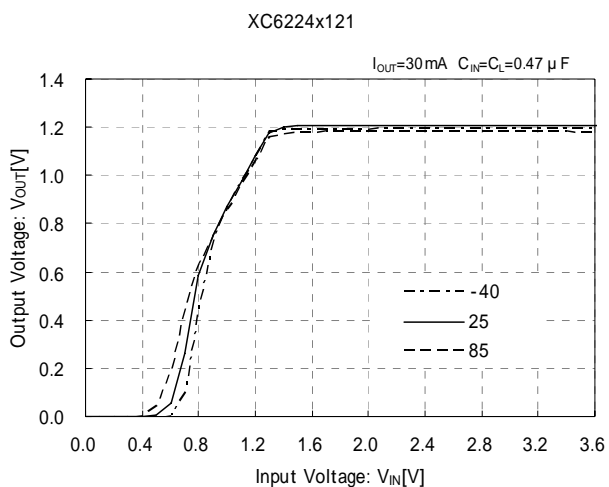

## TYPICAL PERFORMANCE CHARACTERISTICS (Continued)

### (3) Dropout Voltage vs. Output Current

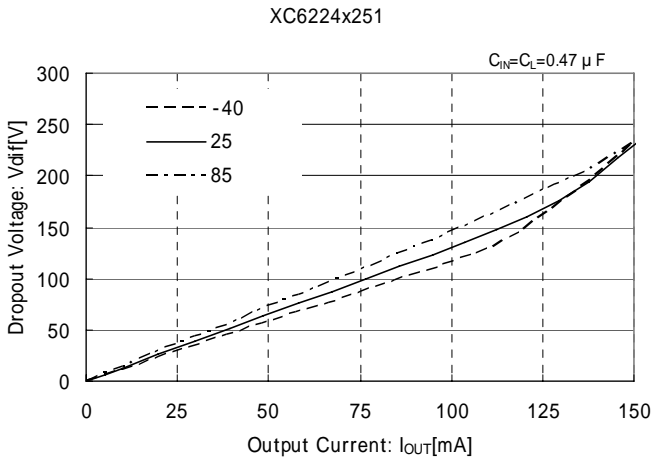
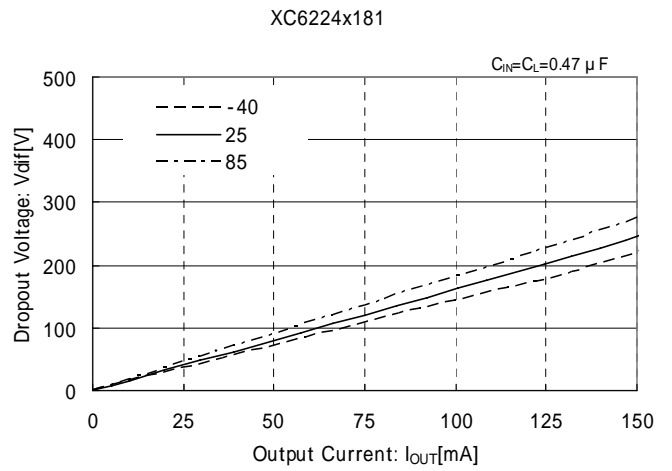
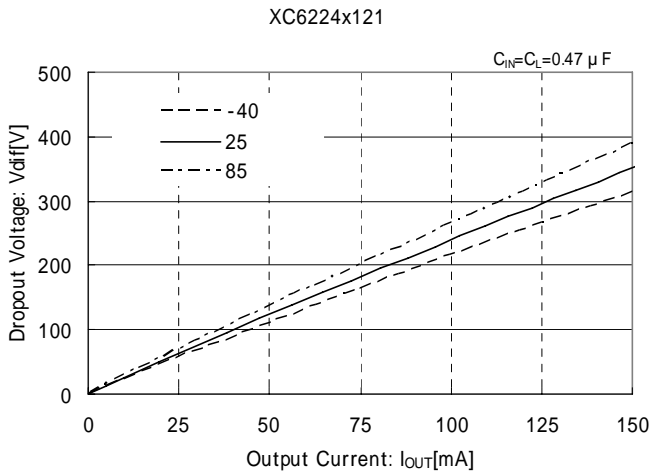

### (4) Supply Current vs. Input Voltage

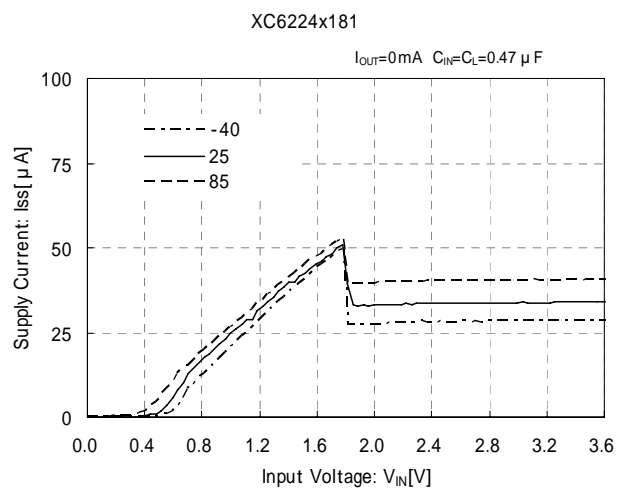
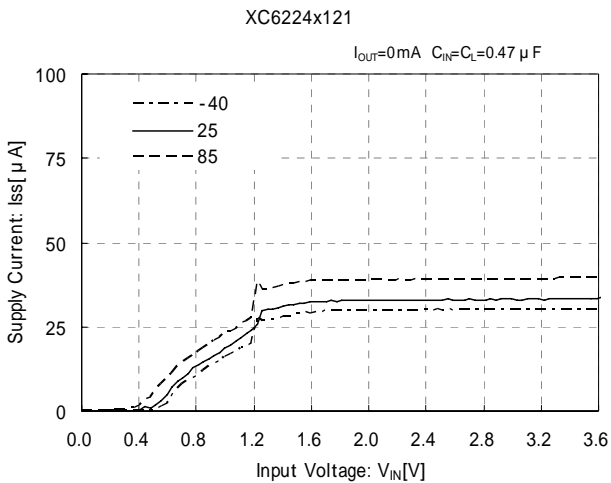

## TYPICAL PERFORMANCE CHARACTERISTICS (Continued)

### (4) Supply Current vs. Input Voltage (Continued)

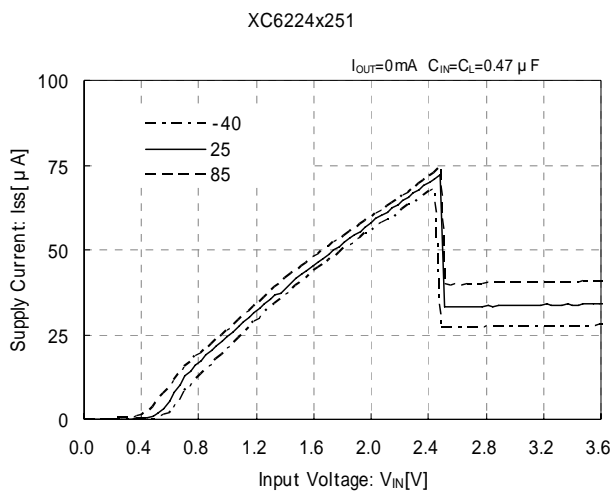

### (5) Output Voltage vs. Ambient Temperature

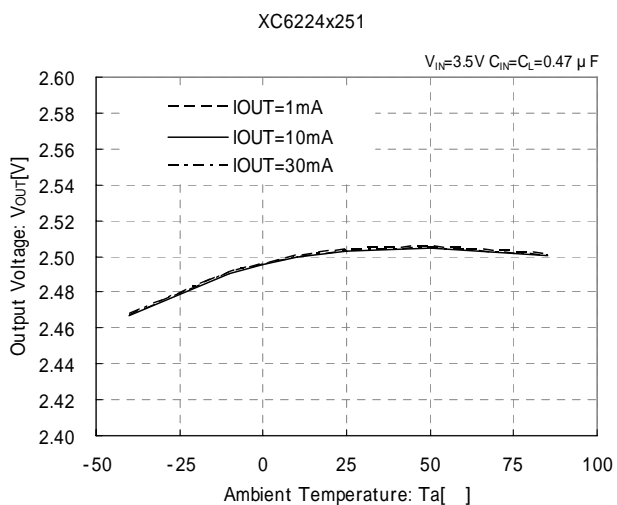
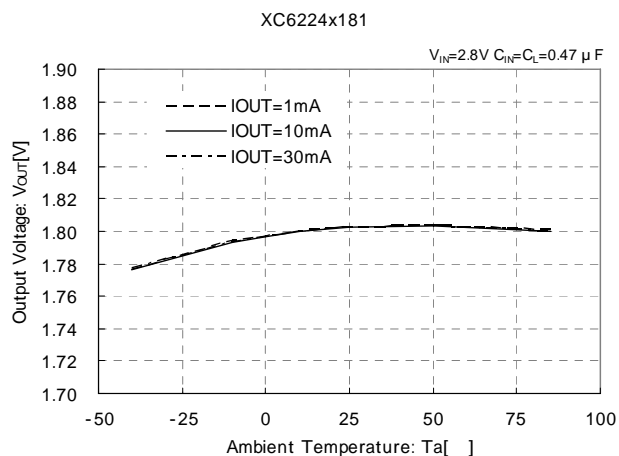
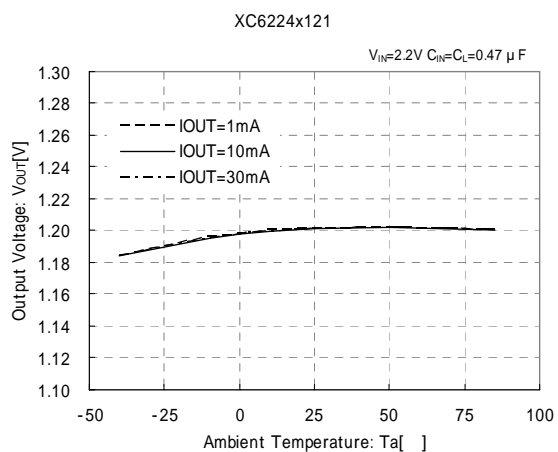

## TYPICAL PERFORMANCE CHARACTERISTICS (Continued)

### (6) Rising Response Time

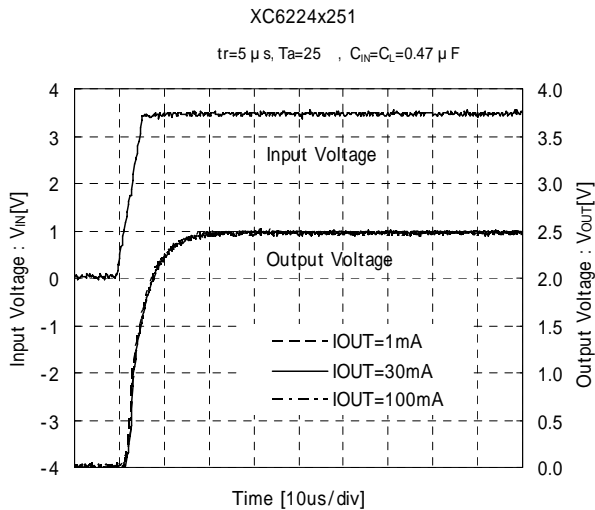
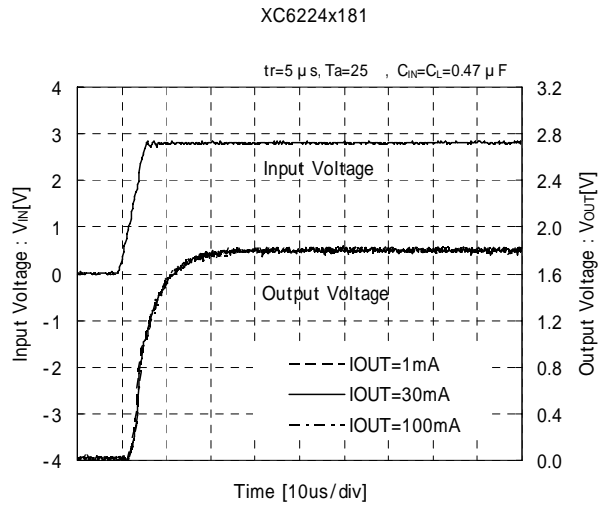
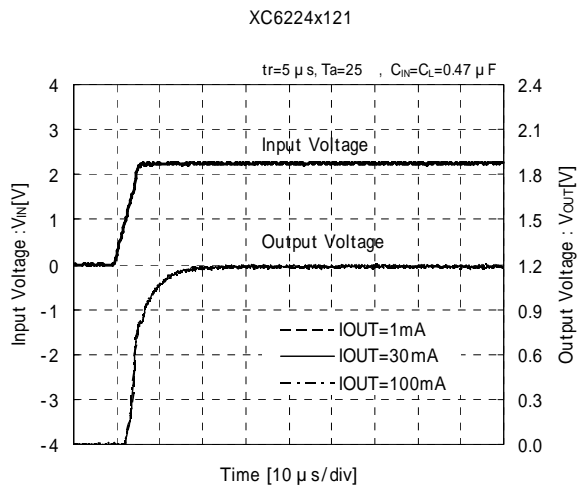

### (7) Input Transient Response

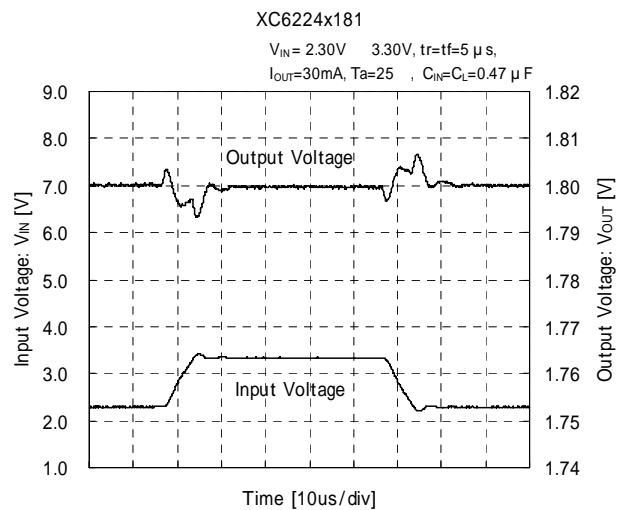
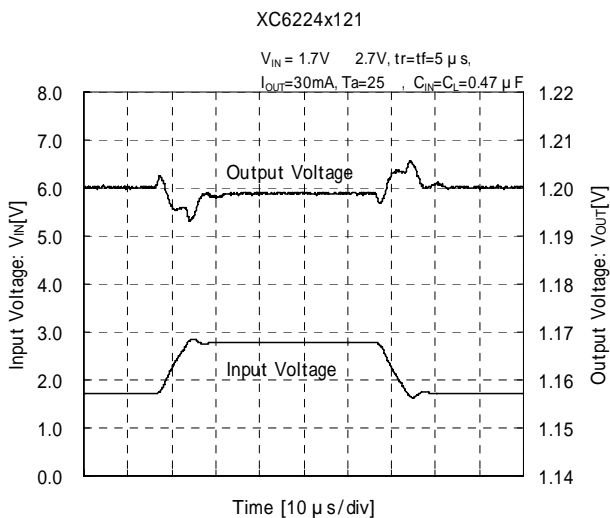

## TYPICAL PERFORMANCE CHARACTERISTICS (Continued)

### (7) Input Transient Response (Continued)

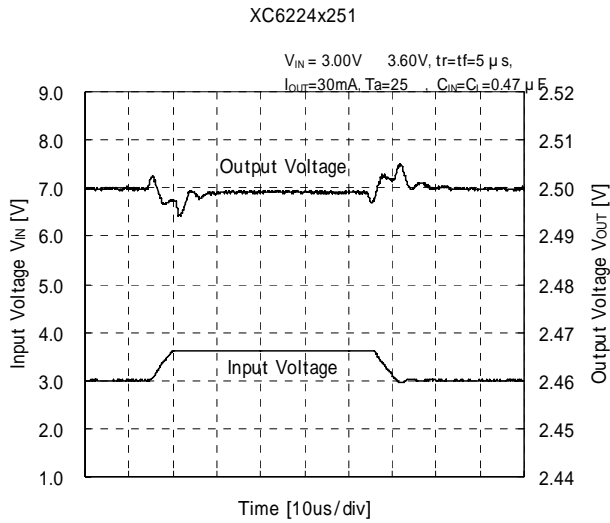

### (8) Load Transient Response

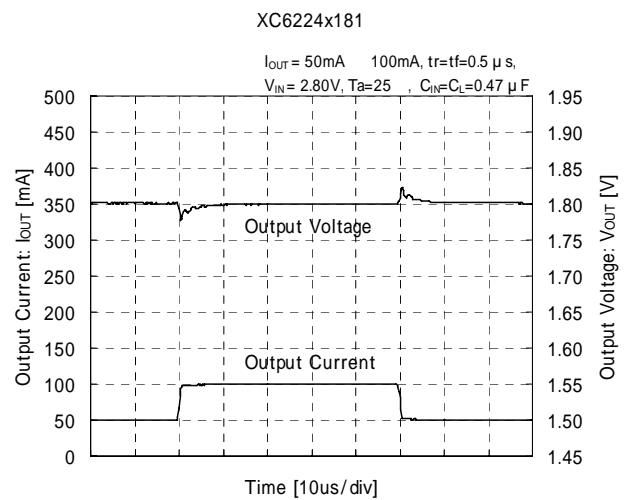
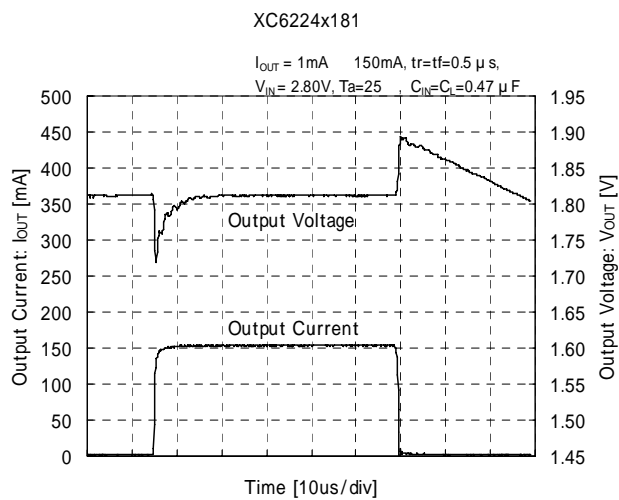
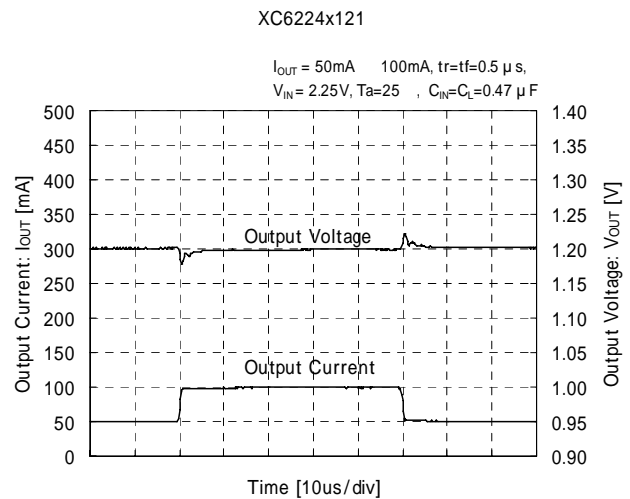
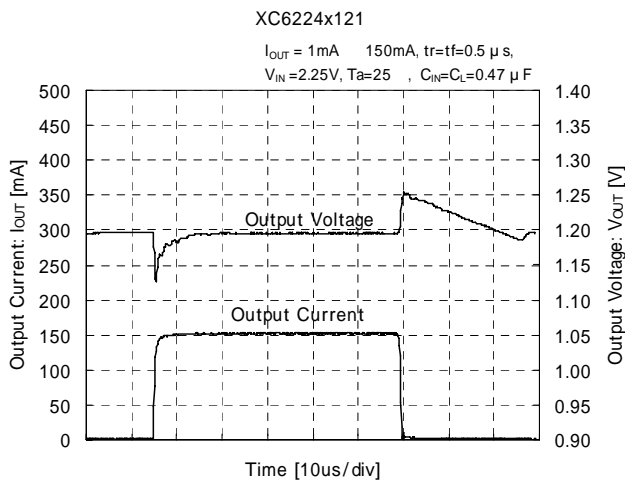

## TYPICAL PERFORMANCE CHARACTERISTICS (Continued)

### (8) Load Transient Response (Continued)

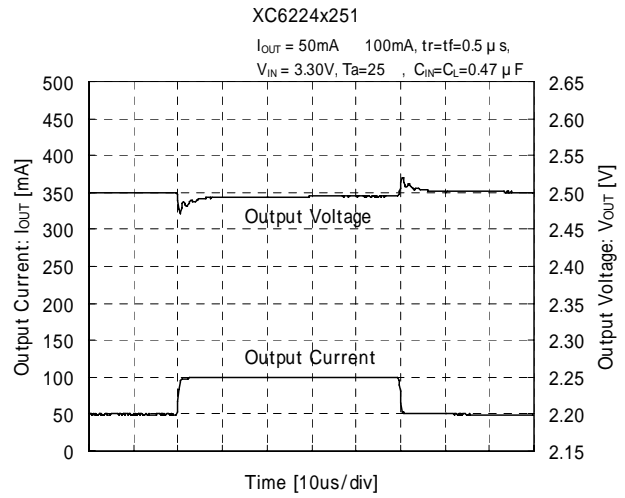
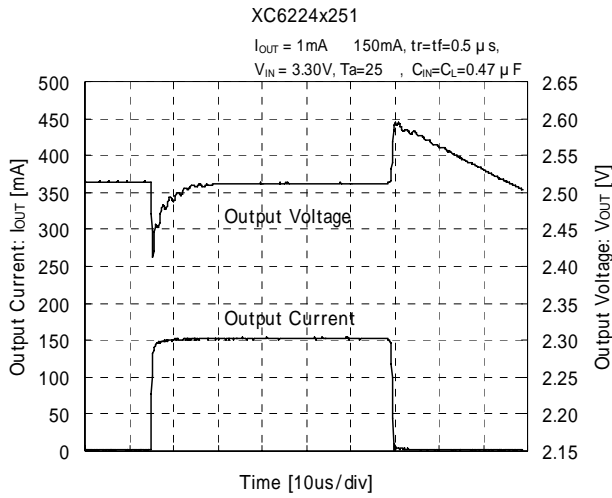

### (9) CE Rising Response Time

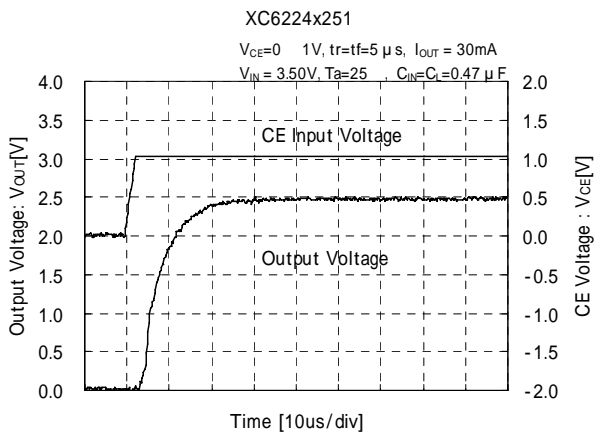
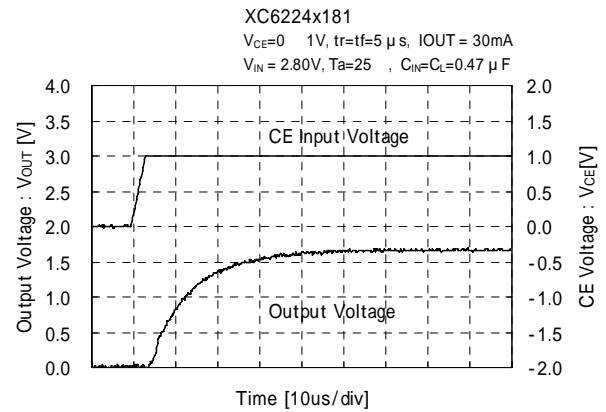
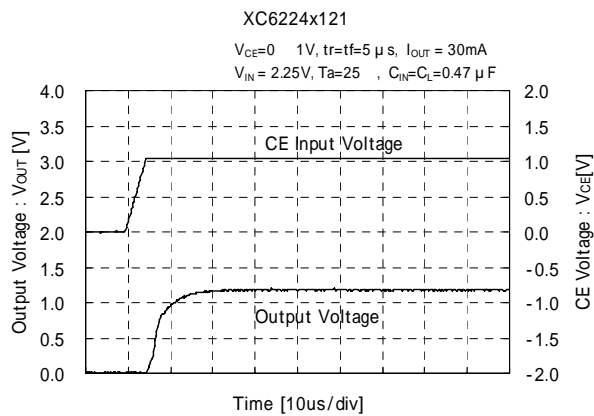



## TYPICAL PERFORMANCE CHARACTERISTICS (Continued)

### (10) $C_L$ Discharge Response Time

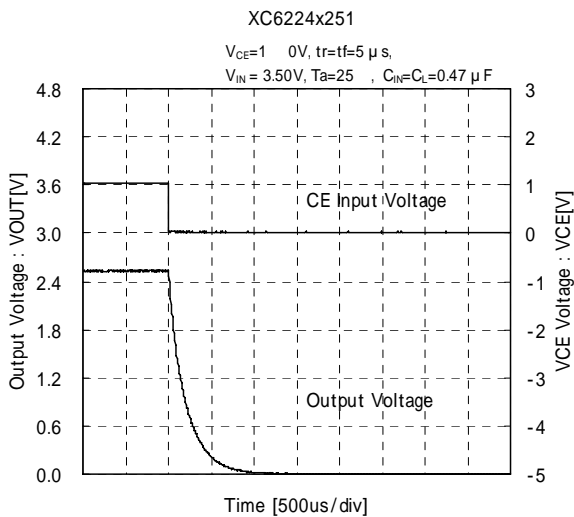
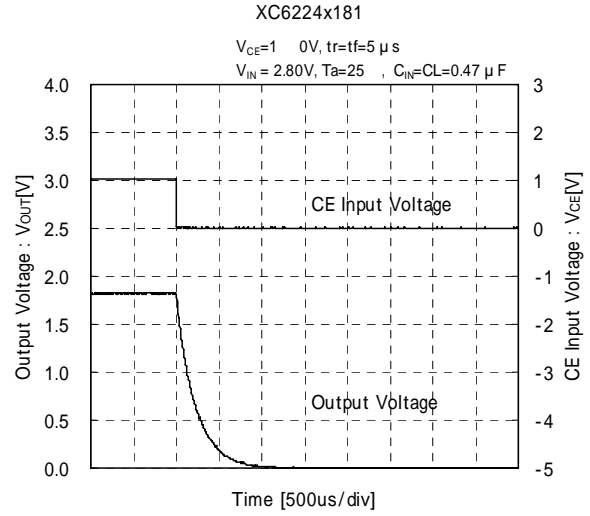
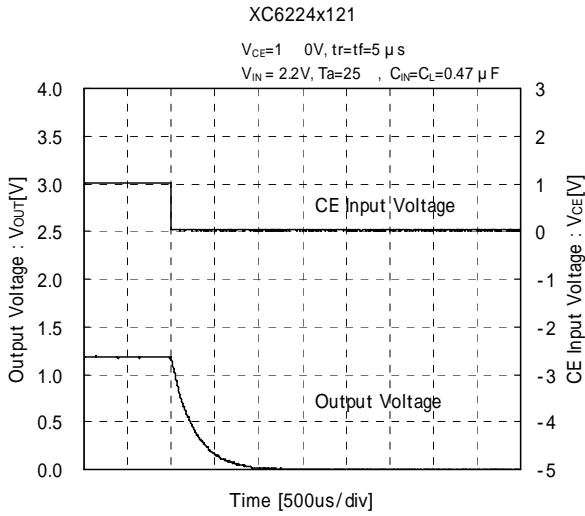

### (11) Ripple Rejection Rate

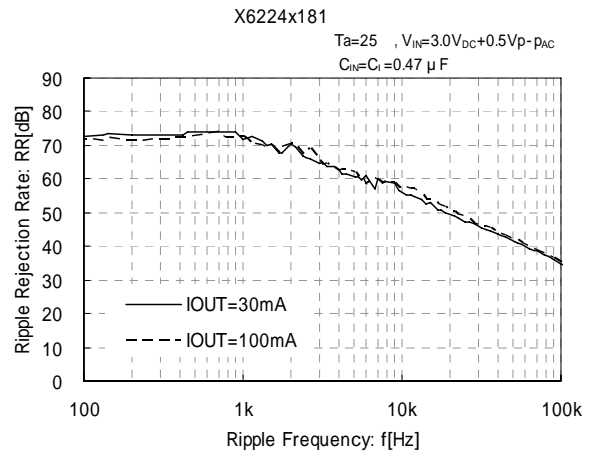
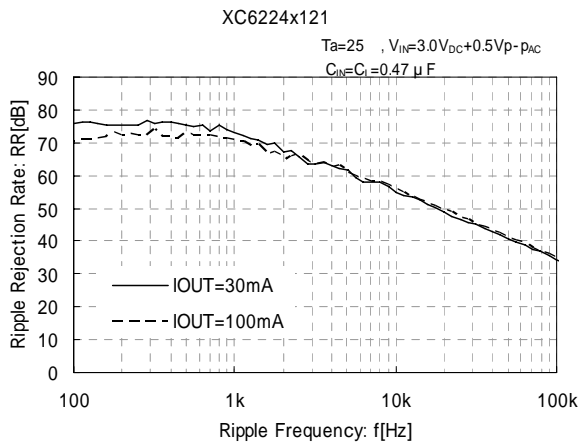

## TYPICAL PERFORMANCE CHARACTERISTICS (Continued)

### (11) Ripple Rejection Rate

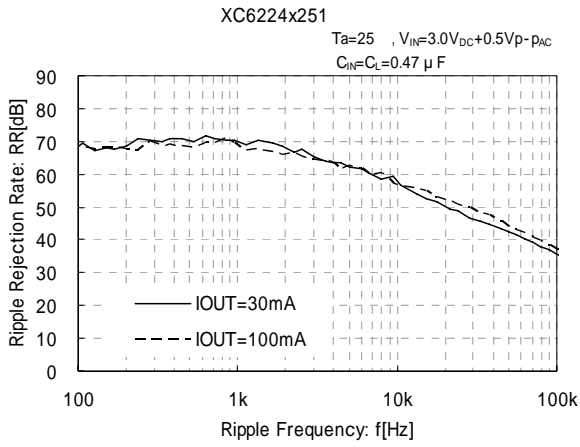

### (12) The Minimum Operating Voltage

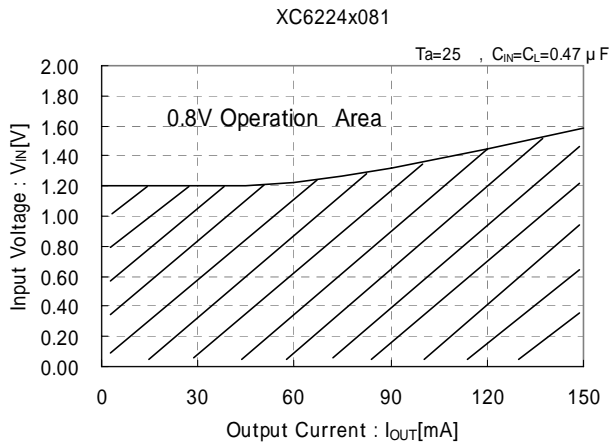

\* The graph shows minimum input voltages as a function of output current. The values are influenced by a driver ON resistance.

# PACKAGING INFORMATION

## USPN-4B02

(unit : mm)

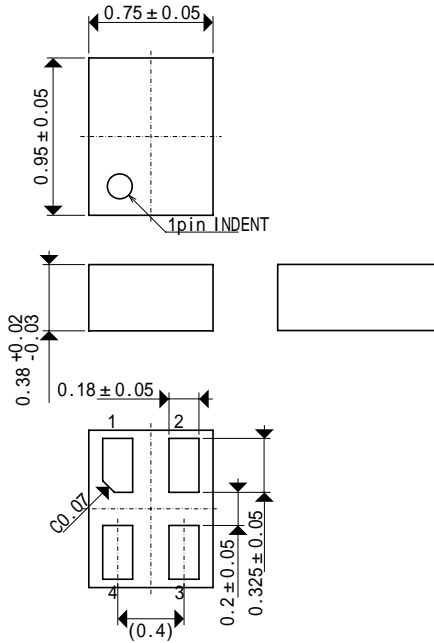

## SSOT-24

(unit : mm)

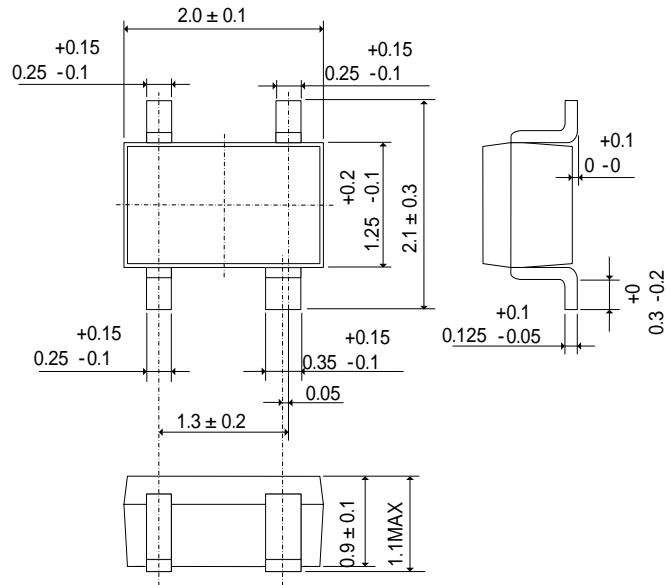

## SOT-25

(unit : mm)

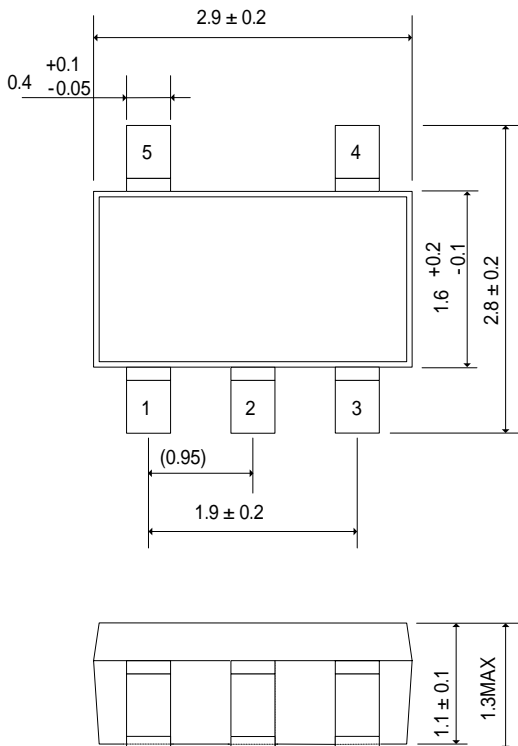

## PACKAGING INFORMATION (Continued)

USPN-4B02 Reference Pattern Layout

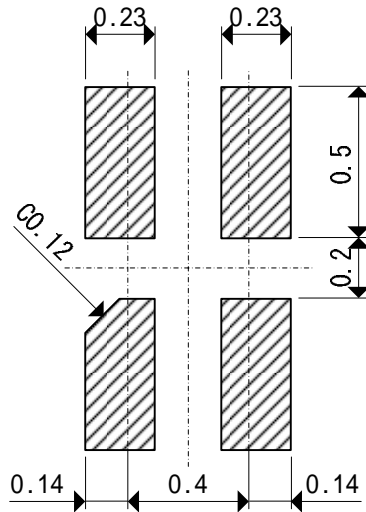

USPN-4B02 Reference Metal Mask Design

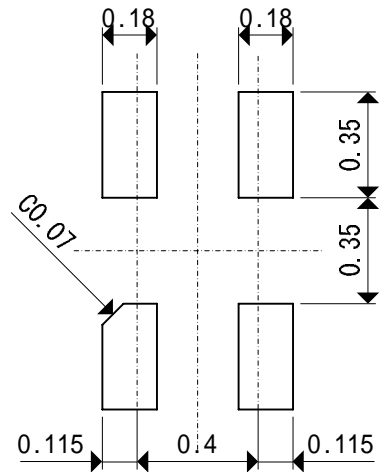

## PACKAGING INFORMATION (Continued)

### SSOT-24 Power Dissipation

Power dissipation data for the SSOT-24 is shown in this page.  
The value of power dissipation varies with the mount board conditions.  
Please use this data as one of reference data taken in the described condition.

#### 1. Measurement Condition (Reference data)

- Condition: Mount on a board
- Ambient: Natural convection
- Soldering: Lead (Pb) free
- Board: Dimensions 40 x 40 mm (1600 mm<sup>2</sup> in one side)  
Copper (Cu) traces occupy 50% of the board area  
In top and back faces  
Package heat-sink is tied to the copper traces
- Material: Glass Epoxy (FR-4)
- Thickness: 1.6 mm
- Through-hole: 4 x 0.8 Diameter

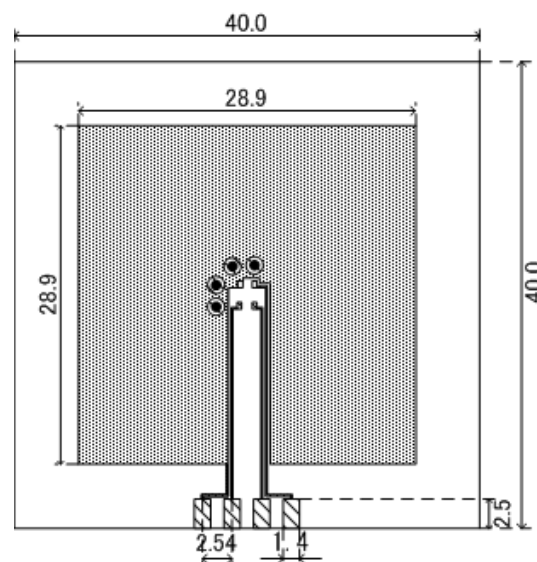

Evaluation Board (Unit: mm)

#### 2. Power Dissipation vs. Ambient temperature

Board Mount ( $T_j \text{ max} = 125$  )

Ambient Temperature ( )	Power Dissipation Pd (mW)	Thermal Resistance ( /W)
25	500	200.00
85	200	

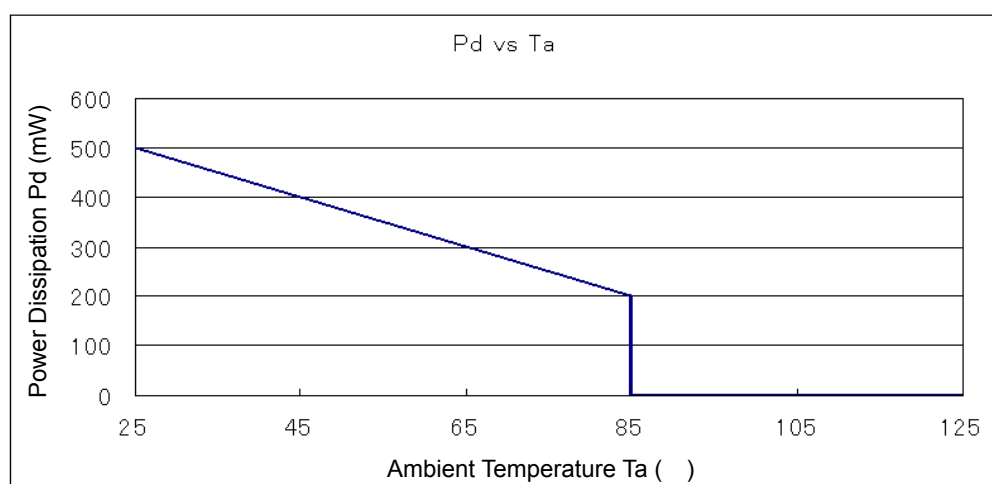

## PACKAGING INFORMATION (Continued)

### SOT-25 Power Dissipation

Power dissipation data for the SOT-25 is shown in this page.  
The value of power dissipation varies with the mount board conditions.  
Please use this data as one of reference data taken in the described condition.

#### 1. Measurement Condition (Reference data)

- Condition: Mount on a board
- Ambient: Natural convection
- Soldering: Lead (Pb) free
- Board: Dimensions 40 x 40 mm (1600 mm<sup>2</sup> in one side)  
Copper (Cu) traces occupy 50% of the board area  
In top and back faces  
Package heat-sink is tied to the copper traces  
(Board of SOT-26 is used.)
- Material: Glass Epoxy (FR-4)
- Thickness: 1.6 mm
- Through-hole: 4 x 0.8 Diameter

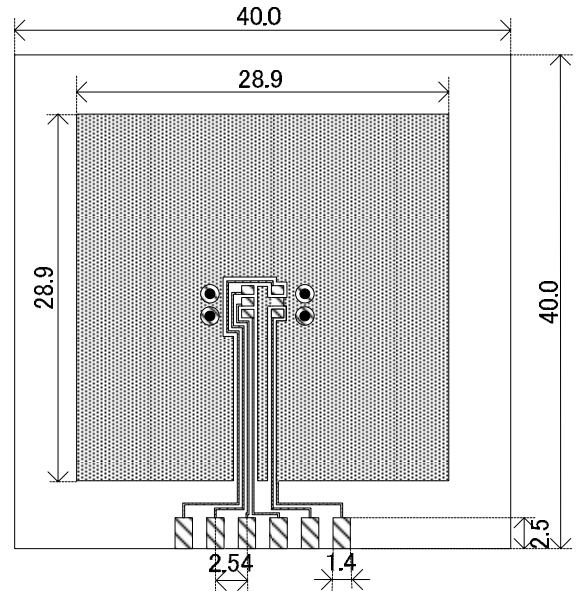

Evaluation Board (Unit: mm)

#### 2. Power Dissipation vs. Ambient temperature

Board Mount ( $T_j \text{ max} = 125$  )

Ambient Temperature ( )	Power Dissipation Pd (mW)	Thermal Resistance ( /W)
25	600	166.67
85	240	

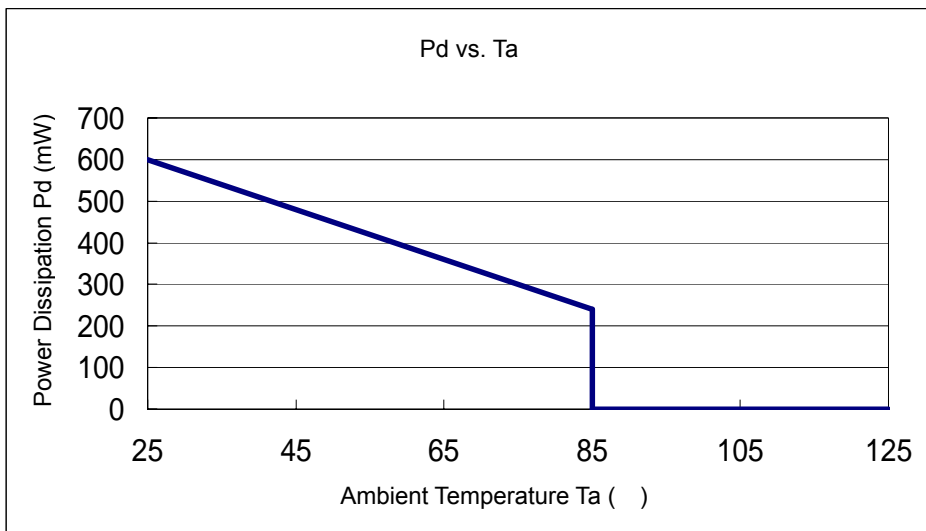

## PACKAGING INFORMATION (Continued)

### USPN-4B02 Power Dissipation

Power dissipation data for the USPN-4B02 is shown in this page.  
The value of power dissipation varies with the mount board conditions.  
Please use this data as one of reference data taken in the described condition.

#### 1. Measurement Condition (Reference data)

Condition: Mount on a board

Ambient: Natural convection

Soldering: Lead (Pb) free

Board: Dimensions 40 x 40 mm (1600 mm<sup>2</sup> in one side)  
Copper (Cu) traces occupy 50% of the front and 50% of the back.  
The copper area is divided into four block,  
one block is 12.5% of total.  
The USPN-4 package has for terminals.  
Each terminal connects one copper block in the front  
and one in the back.

Material: Glass Epoxy (FR-4)

Thickness: 1.6 mm

Through-hole: 4 x 0.8 Diameter

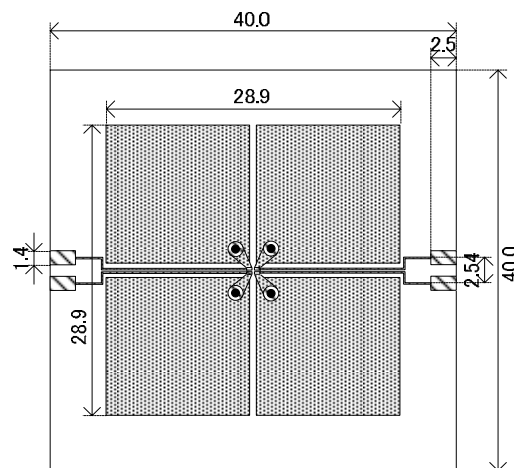

Evaluation Board (Unit: mm)

#### 2. Power Dissipation vs. Ambient temperature

Board Mount ( $T_j \text{ max} = 125$  )

Ambient Temperature ( )	Power Dissipation Pd (mW)	Thermal Resistance ( /W)
25	550	181.82
85	220	

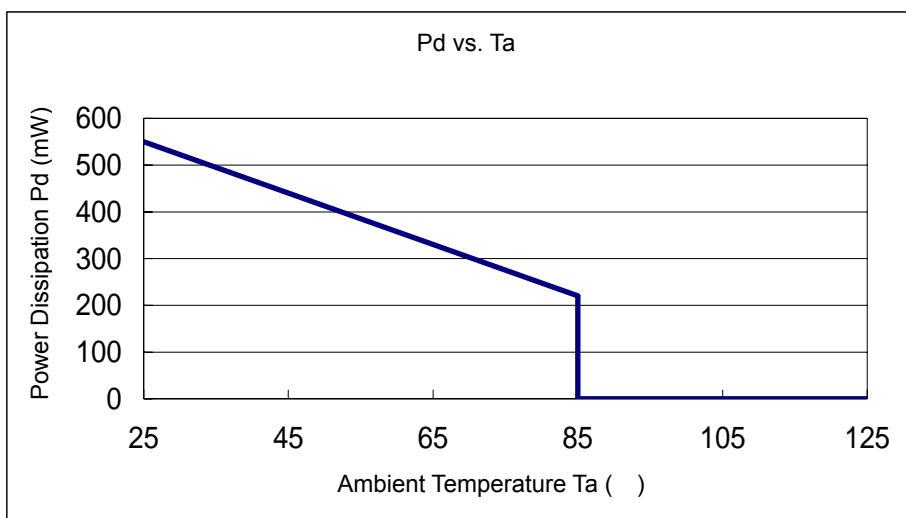

## MARKING RULE

### SOT-25

represents product series

MARK	PRODUCT SERIES
1	XC6224*****-G

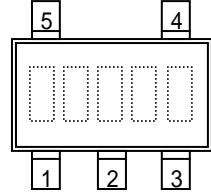

represents type of regulator and combination of output voltage

MARK		PRODUCT SERIES
OUTPUT VOLTAGE 0.1V INCREMENTS	OUTPUT VOLTAGE 0.05V INCREMENTS	
0.8 ~ 3.0V	0.85 ~ 2.95V	
C	H	XC6224A*****-G
D	K	XC6224B*****-G

represents output voltage

MARK	OUTPUT VOLTAGE (V)				MARK	OUTPUT VOLTAGE (V)			
	0.1V INCREMENTS		0.05V INCREMENTS			0.1V INCREMENTS		0.05V INCREMENTS	
0	0.80	-	0.85	-	F	2.30	-	2.35	-
1	0.90	-	0.95	-	H	2.40	-	2.45	-
2	1.00	-	1.05	-	K	2.50	-	2.55	-
3	1.10	-	1.15	-	L	2.60	-	2.65	-
4	1.20	-	1.25	-	M	2.70	-	2.75	-
5	1.30	-	1.35	-	N	2.80	-	2.85	-
6	1.40	-	1.45	-	P	2.90	-	2.95	-
7	1.50	-	1.55	-	R	3.00	-	-	-
8	1.60	-	1.65	-	S	-	-	-	-
9	1.70	-	1.75	-	T	-	-	-	-
A	1.80	-	1.85	-	U	-	-	-	-
B	1.90	-	1.95	-	V	-	-	-	-
C	2.00	-	2.05	-	X	-	-	-	-
D	2.10	-	2.15	-	Y	-	-	-	-
E	2.20	-	2.25	-	Z	-	-	-	-

represents production lot number

1 ~ 09, 0A ~ 0Z, 11...9Z, A1 ~ A9, AA...Z9, ZA ~ ZZ repeated.

(G, I, J, O, Q, W excluded.)

\* No character inversion used.



## MARKING RULE (Continued)

SSOT24 (with bar)

represents type of regulator and combination of output voltage

MARK				PRODUCT SERIES
OUTPUT VOLTAGE 0.1V INCREMENTS		OUTPUT VOLTAGE 0.05V INCREMENTS		
VOLTAGE =0.8 ~ 2.4V	VOLTAGE =2.5 ~ 3.0V	VOLTAGE =0.85 ~ 1.95V	VOLTAGE =2.05 ~ 2.95V	
A	F	F	Z	XC6224A****-G
H	P	P	R	XC6224B****-G

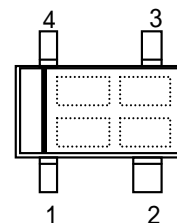

represents output voltage

MARK	OUTPUT VOLTAGE (V)					MARK	OUTPUT VOLTAGE (V)			
	XC6224A/B			XC6224A			XC6224A/B		XC6224B	
0	0.80	0.85	-	2.05	-	F	-	-	-	-
1	0.90	0.95	-	2.15	-	H	-	-	-	-
2	1.00	1.05	-	2.25	-	K	-	-	-	-
3	1.10	1.15	-	2.35	-	L	-	-	-	-
4	1.20	1.25	-	2.45	-	M	-	-	-	-
5	1.30	1.35	-	2.55	-	N	2.10	-	2.05	-
6	1.40	1.45	-	2.65	-	P	-	-	2.15	-
7	1.50	1.55	-	2.75	-	R	-	-	2.25	-
8	1.60	1.65	-	2.85	-	S	-	-	2.35	-
9	1.70	1.75	-	2.95	-	T	-	-	2.45	-
A	1.80	1.85	-	-	-	U	2.20	2.60	2.55	-
B	1.90	1.95	-	-	-	V	2.30	2.70	2.65	-
C	2.00	-	2.50	-	-	X	2.40	2.80	2.75	-
D	-	-	-	-	-	Y	-	2.90	2.85	-
E	-	-	-	-	-	Z	-	3.00	2.95	-

represents production lot number

01 ~ 09, 0A ~ 0Z, 11...9Z, A1 ~ A9, AA...Z9, ZA ~ ZZ repeated.

(G, I, J, O, Q, W excluded.)

\* No character inversion used.

## MARKING RULE (Continued)

USPN-4B02

represents type of regulator and combination of output voltage

MARK		PRODUCT SERIES
OUTPUT VOLTAGE 0.1V INCREMENTS	OUTPUT VOLTAGE 0.05V INCREMENTS	
VOLTAGE =0.8 ~ 3.0V	VOLTAGE =0.85 ~ 2.95V	
0	1	XC6224A****-G
2	3	XC6224B****-G

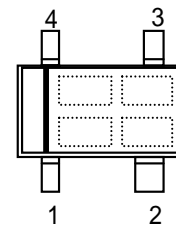

represents output voltage

MARK	OUTPUT VOLTAGE (V)		MARK	OUTPUT VOLTAGE (V)	
0	0.80	0.85	F	2.30	2.35
1	0.90	0.95	H	2.40	2.45
2	1.00	1.05	K	2.50	2.55
3	1.10	1.15	L	2.60	2.65
4	1.20	1.25	M	2.70	2.75
5	1.30	1.35	N	2.80	2.85
6	1.40	1.45	P	2.90	2.95
7	1.50	1.55	R	3.00	-
8	1.60	1.65	S	-	-
9	1.70	1.75	T	-	-
A	1.80	1.85	U	-	-
B	1.90	1.95	V	-	-
C	2.00	2.05	X	-	-
D	2.10	2.15	Y	-	-
E	2.20	2.25	Z	-	-

represents production lot number

0 ~ 9, A ~ Z repeated.

(G, I, J, O, Q, W excluded.)

\* No character inversion used.

1. The products and product specifications contained herein are subject to change without notice to improve performance characteristics. Consult us, or our representatives before use, to confirm that the information in this datasheet is up to date.
2. We assume no responsibility for any infringement of patents, patent rights, or other rights arising from the use of any information and circuitry in this datasheet.
3. Please ensure suitable shipping controls (including fail-safe designs and aging protection) are in force for equipment employing products listed in this datasheet.
4. The products in this datasheet are not developed, designed, or approved for use with such equipment whose failure of malfunction can be reasonably expected to directly endanger the life of, or cause significant injury to, the user.  
(e.g. Atomic energy; aerospace; transport; combustion and associated safety equipment thereof.)
5. Please use the products listed in this datasheet within the specified ranges.  
Should you wish to use the products under conditions exceeding the specifications, please consult us or our representatives.
6. We assume no responsibility for damage or loss due to abnormal use.
7. All rights reserved. No part of this datasheet may be copied or reproduced without the prior permission of TOREX SEMICONDUCTOR LTD.

**TOREX SEMICONDUCTOR LTD.**

# Mouser Electronics

Authorized Distributor

Click to View Pricing, Inventory, Delivery & Lifecycle Information:

## Torex Semiconductor:

[XC6224A12BMR-G](#) [XC6224A1217R-G](#) [XC6224A1617R-G](#) [XC6224A081MR-G](#) [XC6224A08BMR-G](#)  
[XC6224A11B7R-G](#) [XC6224A181MR-G](#) [XC6224A281NR-G](#) [XC6224B181MR-G](#) [XC6224B28B7R-G](#) [XC6224A191MR-G](#)  
[XC6224A241NR-G](#) [XC6224B181NR-G](#) [XC6224B2817R-G](#) [XC6224A091NR-G](#) [XC6224A12B7R-G](#)  
[XC6224A1517R-G](#) [XC6224A18BMR-G](#) [XC6224A231NR-G](#) [XC6224B121MR-G](#) [XC6224A121NR-G](#) [XC6224A131MR-G](#)  
[XC6224A091MR-G](#) [XC6224A101NR-G](#) [XC6224A081NR-G](#) [XC6224A0917R-G](#) [XC6224A12BNR-G](#)  
[XC6224A111NR-G](#) [XC6224A271NR-G](#) [XC6224A151MR-G](#) [XC6224A261NR-G](#) [XC6224A1817R-G](#) [XC6224A11BMR-G](#)  
[XC6224B3017R-G](#) [XC6224A121MR-G](#) [XC6224A1417R-G](#) [XC6224A09BMR-G](#) [XC6224A0817R-G](#)  
[XC6224A111MR-G](#) [XC6224A101MR-G](#) [XC6224A301NR-G](#) [XC6224A181NR-G](#) [XC6224A2517R-G](#) [XC6224A251NR-G](#)  
[XC6224A201NR-G](#) [XC6224B2517R-G](#) [XC6224B2717R-G](#) [XC6224A1117R-G](#) [XC6224A3017R-G](#)  
[XC6224A201MR-G](#) [XC6224A221NR-G](#) [XC6224A10BMR-G](#) [XC6224A1017R-G](#) [XC6224A10BNR-G](#) [XC6224A13B7R-G](#)  
[XC6224A2817R-G](#) [XC6224B151MR-G](#)