

400mA Inductor Built-in Step-Down "micro DC/DC" Converters

☆GreenOperation Compatible

■GENERAL DESCRIPTION

The XCL208/XCL209 series is a synchronous step-down micro DC/DC converter which integrates an inductor and a control IC in one tiny package (2.5mm×2.15mm, h=1.05mm). A stable power supply with an output current of 400mA is configured using only two capacitors connected externally.

An internal coil simplifies the circuit and enables minimization of noise and other operational trouble due to the circuit wiring.

A wide operating voltage range of 1.8V (2.0V) to 6.0V enables support for applications that require an alkaline battery (2-cell) or AC adapter (5V) power supply. An internally fixed output voltage (0.8V to 4.0V) or an externally set output voltage can be selected.

The XCL208/XCL209 series uses synchronous rectification at an operating frequency of 3.0MHz. PWM control (XCL208) or automatic PWM/PFM switching control (XCL209) can be selected. The XCL208 series has a fixed frequency, enabling the suppression of output ripple. The XCL209 series achieves high efficiency while holding down output ripple across the full range of loads, from light to heavy, enabling the extension of battery operation time.

Soft start and on/off functions with C_L discharge are provided, and the IC can be put in the standby state by inputting a Low level signal into the CE pin.

■APPLICATIONS

- Mobile phones, Smart phones
- Bluetooth Headsets
- Tablet PCs
- PND
- PC peripheral devices
- DSC, Camcorders

■TYPICAL APPLICATION CIRCUIT

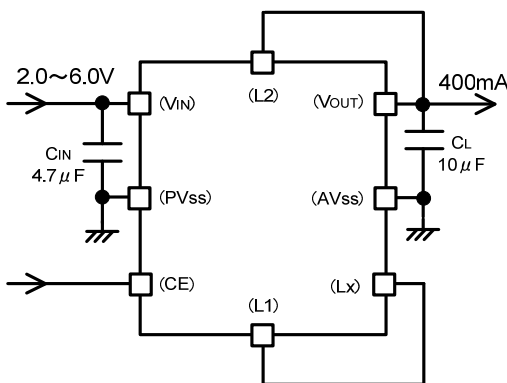

XCL208A / XCL208B / XCL209A / XCL209B Type

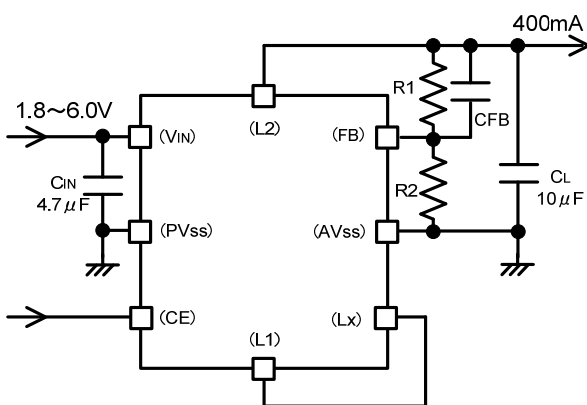

XCL208F / XCL209F Type

■FEATURES

| | |
|-------------------------------|---------------------------------------|
| Input Voltage | : 1.8V ~ 6.0V (Type F) |
| | : 2.0V ~ 6.0V (Type A/B) |
| Fixed Output Voltage | : 0.8V ~ 4.0V ($\pm 2.0\%$) |
| High Efficiency | : 90% ($V_{IN}=4.2V, V_{OUT}=3.3V$) |
| Output Current | : 400mA |
| Oscillation Frequency | : 3.0MHz ($\pm 15\%$) |
| CE Function | : Active High |
| | Soft-start Circuit Built-in |
| | C_L High Speed Auto Discharge |
| Protection Circuits | : Current Limiter Built-in |
| | (Constant Current & Latching) |
| Control Methods | : PWM (XCL208) |
| | PWM/PFM (XCL209) |
| Operating Ambient Temperature | : $-40^{\circ}C \sim +85^{\circ}C$ |
| Package | : USP-10B03 |
| Environmentally Friendly | : EU RoHS Compliant, Pb Free |

■TYPICAL PERFORMANCE CHARACTERISTICS

● Efficiency vs. Output Current
XCL208x333DR/XCL209x333D

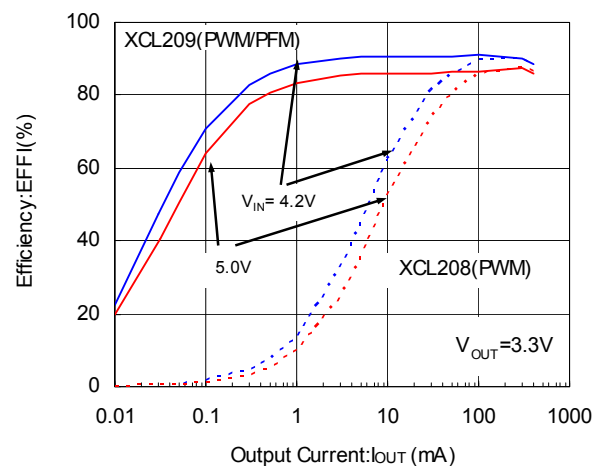

XCL208/XCL209 Series

BLOCK DIAGRAM

1) XCL208A / XCL209A Type

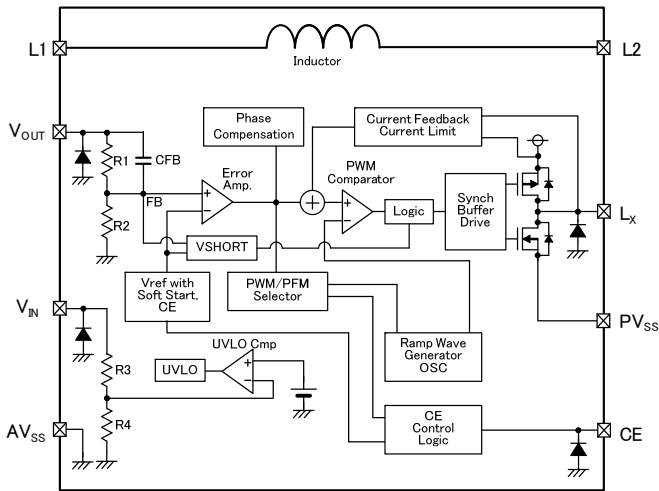

2) XCL208B / XCL209B Type

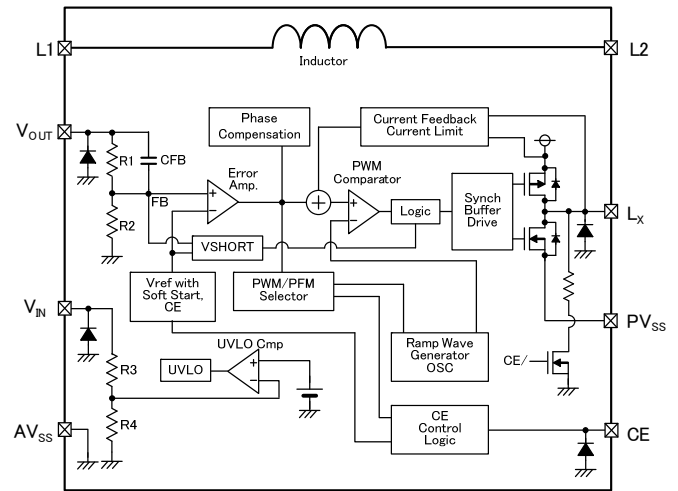

3) XCL208F / XCL209F Type

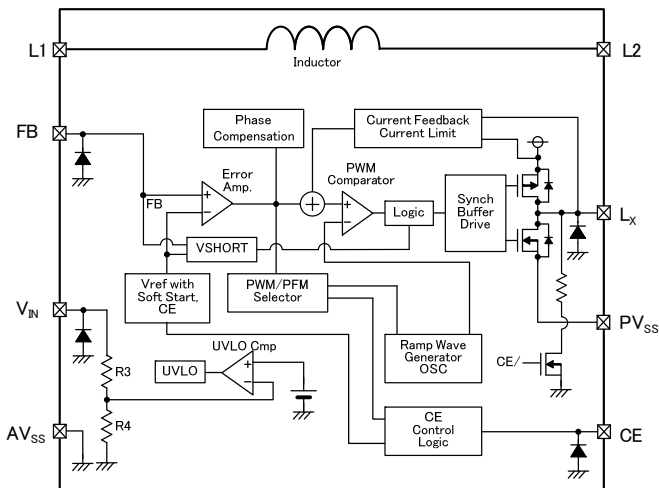

NOTE:

The XCL208 offers a fixed PWM control, a signal from CE Control Logic to PWM/PFM Selector is fixed to "L" level inside. The XCL209 control scheme is PWM/PFM automatic switching, a signal from CE Control Logic to PWM/PFM Selector is fixed to "H" level inside. The diodes placed inside are ESD protection diodes and parasitic diodes.

■ PRODUCT CLASSIFICATION

XCL208①②③④⑤⑥ Fixed PWM

XCL209①②③④⑤⑥ PWM/PFM Auto Switching

| DESIGNATOR | ITEM | SYMBOL | DESCRIPTION |
|-------------------|-------------------------------|--------|---|
| ① | Type | A | $V_{IN} \geq 2.0V$ Fixed Output Voltage Standard soft-start , No C_L auto discharge |
| | | B | $V_{IN} \geq 2.0V$ Fixed Output Voltage C_L auto discharge, High speed soft-start |
| | | F | $V_{IN} \geq 1.8V$ Output Voltage External Setting C_L auto discharge, High speed soft-start |
| ②③ | Output Voltage ^(*) | 10 | 1.0V |
| | | 12 | 1.2V |
| | | 15 | 1.5V |
| | | 18 | 1.8V |
| | | 25 | 2.5V |
| | | 28 | 2.8V |
| | | 2L | 2.85V |
| | | 30 | 3.0V |
| | | 33 | 3.3V |
| | | 08 | External Setting 0.8V (XCL208F/XCL209F) |
| ④ | Oscillation Frequency | 3 | 3.0MHz |
| ⑤⑥ ^(*) | Package (Order Unit) | DR | USP-10B03 (3,000psc/Reel) |

^(*) When other output voltages (semi-custom) are needed, please contact your local Torex sales office for more information.

Output voltage range is 0.8~4.0V.

^(*) Halogen free and EU RoHS compliant.

PIN CONFIGURATION

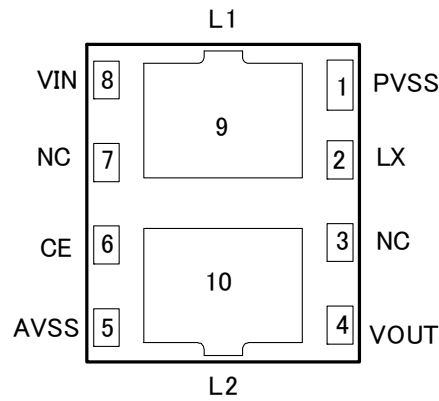

(BOTTOM VIEW)

PIN ASSIGNMENT

| PIN NUMBER USP-10B03 | PIN NAME | FUNCTIONS |
|-------------------------|----------|-------------------------------------|
| 1 | PVSS | (Power) Ground |
| 2 | LX | Switching Output |
| 3 | NC | No Connection |
| 4 | FB | Output Voltage Sense Pin (Type F) |
| | VOUT | Fixed Output Voltage Pin (Type A/B) |
| 5 | AVSS | (Analog) Ground |
| 6 | CE | Active High Enable |
| 7 | NC | No Connection |
| 8 | VIN | Power Supply Input |
| 9 | L1 | Inductor Electrodes |
| 10 | L2 | Inductor Electrodes |

FUNCTION

| PIN NAME | SIGNAL | CONDITIONS | STATUS |
|----------|--------|----------------------------------|----------|
| CE | L | $AV_{SS} \leq V_{CE} \leq 0.25V$ | Stand-by |
| | H | $0.65V \leq V_{CE} \leq 6V$ | Active |

* When the CE pin is left open, the IC may operate unstable. Please do not leave the CE pin open.

ABSOLUTE MAXIMUM RATINGS

Ta=25°C

| PARAMETER | SYMBOL | RATINGS | UNITS |
|----------------------------------|------------------|-------------------------------|-------|
| Input Voltage | V _{IN} | -0.3~6.5 | V |
| Lx Pin Voltage | V _{Lx} | -0.3~V _{IN} +0.3≦6.5 | V |
| Output Voltage | V _{OUT} | -0.3~6.5 | V |
| FB Pin Voltage | V _{FB} | -0.3~6.5 | V |
| CE Input Voltage | V _{CE} | -0.3~6.5 | V |
| Lx Pin Current | I _{Lx} | ±1500 | mA |
| Power Dissipation ^(*) | P _d | 500 | mW |
| Operating Ambient Temperature | Topr | -40~+85 | °C |
| Storage Temperature | Tstg | -40~+125 | °C |

Each voltage rating uses the V_{SS} pin as a reference.

^(*) The value is an example data which is taken with the PCB mounted.

ELECTRICAL CHARACTERISTICS

1) XCL208Axx3DR/XCL209Axx3DR

Ta=25°C

| PARAMETER | SYMBOL | CONDITIONS | MIN. | TYP. | MAX. | UNIT | CIRCUIT |
|--|---|---|------------------|-------|--------|--------|---------|
| Output Voltage | V _{OUT} | V _{IN} =V _{CE} =5.0V, I _{OUT} =30mA | <E-1> | <E-2> | <E-3> | V | ① |
| Operating Voltage Range | V _{IN} | | 2.0 | - | 6.0 | V | ① |
| Maximum Output Current | I _{OUTMAX} | V _{IN} =V _{OUT(T)} +2.0V, V _{CE} =1.0V ⁽⁸⁾ | 400 | - | - | mA | ① |
| UVLO Voltage | V _{UVLO} | V _{CE} =V _{IN} , V _{OUT} =0V, Voltage which Lx pin holding "L" level ^{(11),(10)} | 1.00 | 1.40 | 1.78 | V | ③ |
| Supply Current (XCL208) | I _{DD} | V _{IN} =V _{CE} =5.0V, V _{OUT} =V _{OUT(T)} ×1.1V | - | 46 | 65 | μA | ② |
| Supply Current (XCL209) | | | - | 21 | 35 | | |
| Stand-by Current | I _{STB} | V _{IN} =5.0V, V _{CE} =0V, V _{OUT} =V _{OUT(T)} ×1.1V | - | 0 | 1 | μA | ② |
| Oscillation Frequency | f _{OSC} | V _{IN} =V _{OUT(T)} +2.0V, V _{CE} =1.0V, I _{OUT} =100mA | 2.55 | 3.00 | 3.45 | MHz | ① |
| PFM Switching Current ⁽¹¹⁾ | I _{PFM} | V _{IN} =V _{OUT(T)} +2.0V, V _{CE} =V _{IN} , I _{OUT} =1mA | <E-4> | <E-5> | <E-6> | mA | ⑩ |
| PFM Duty Limit ⁽¹¹⁾ | DTY _{LIMIT_PFM} | V _{CE} =V _{IN} =<C-1>, I _{OUT} =1mA | - | 200 | 300 | % | ① |
| Maximum Duty Cycle | D _{MAX} | V _{IN} =V _{CE} =5.0V, V _{OUT} =V _{OUT(T)} ×0.9V | 100 | - | - | % | ③ |
| Minimum Duty Cycle | D _{MIN} | V _{IN} =V _{CE} =5.0V, V _{OUT} =V _{OUT(T)} ×1.1V | - | - | 0 | % | ③ |
| Efficiency ⁽²⁾ | EFFI | When connected to external components, V _{CE} =V _{IN} =V _{OUT(T)} +1.2V, I _{OUT} =100mA | - | <E-7> | - | % | ① |
| L _X SW "H" ON Resistance 1 | R _{LxH1} | V _{IN} =V _{CE} =5.0V, V _{OUT} =0V, I _{Lx} =100mA ⁽³⁾ | - | 0.35 | 0.55 | Ω | ④ |
| L _X SW "H" ON Resistance 2 | R _{LxH2} | V _{IN} =V _{CE} =3.6V, V _{OUT} =0V, I _{Lx} =100mA ⁽³⁾ | - | 0.42 | 0.67 | Ω | ④ |
| L _X SW "L" ON Resistance 1 | R _{LxL1} | V _{IN} =V _{CE} =5.0V ⁽⁴⁾ | - | 0.45 | 0.65 | Ω | - |
| L _X SW "L" ON Resistance 2 | R _{LxL2} | V _{IN} =V _{CE} =3.6V ⁽⁴⁾ | - | 0.52 | 0.77 | Ω | - |
| L _X SW "H" Leakage Current ⁽⁵⁾ | I _{LeakH} | V _{IN} =V _{OUT} =5.0V, V _{CE} =0V, V _{Lx} =0V | - | 0.01 | 1.00 | μA | ⑤ |
| L _X SW "L" Leakage Current ⁽⁵⁾ | I _{LeakL} | V _{IN} =V _{OUT} =5.0V, V _{CE} =0V, V _{Lx} =5.0V | - | 0.01 | 1.00 | μA | ⑤ |
| Current Limit ⁽⁹⁾ | I _{LIM} | V _{IN} =V _{CE} =5.0V, V _{OUT} =V _{OUT(T)} ×0.9V ⁽⁷⁾ | 600 | 800 | 1000 | mA | ⑥ |
| Output Voltage Temperature Characteristics | ΔV _{OUT} / (V _{OUT} ·ΔTopr) | I _{OUT} =30mA, -40°C ≤ Topr ≤ 85°C | - | ±100 | - | ppm/°C | ① |
| CE "H" Voltage | V _{CEH} | V _{OUT} =0V, Applied voltage to V _{CE} , Voltage changes Lx to "H" level ⁽¹⁰⁾ | 0.65 | - | 6.00 | V | ③ |
| CE "L" Voltage | V _{CEL} | V _{OUT} =0V, Applied voltage to V _{CE} , Voltage changes Lx to "L" level ⁽¹⁰⁾ | AV _{SS} | - | 0.25 | V | ③ |
| CE "H" Current | I _{CEH} | V _{IN} =V _{CE} =5.0V, V _{OUT} =0V | -0.1 | - | 0.1 | μA | ⑤ |
| CE "L" Current | I _{CEL} | V _{IN} =5.0V, V _{CE} =0V, V _{OUT} =0V | -0.1 | - | 0.1 | μA | ⑤ |
| Soft-start Time | t _{SS} | V _{CE} =0V→V _{IN} , I _{OUT} =1mA | 0.5 | 0.90 | 2.50 | ms | ① |
| Latch Time | t _{LAT} | V _{IN} =V _{CE} =5.0V, V _{OUT} =0.8×V _{OUT(T)} , Short Lx at 1Ω resistance ⁽⁶⁾ | 1 | - | 20 | ms | ⑦ |
| Short Protection Threshold Voltage | V _{SHORT} | Sweeping V _{OUT} , V _{IN} =V _{CE} =5.0V, Short Lx at 1Ω resistance, V _{OUT} voltage which Lx becomes "L" level within 1ms | <E-8> | <E-9> | <E-10> | V | ⑦ |
| Inductance Value | L | Test Frequency=1MHz | - | 1.5 | - | μH | - |
| Allowed Inductor Current | I _{DC} | ΔT=40°C | - | 700 | - | mA | - |

Test conditions: Unless otherwise stated, V_{IN}=5.0V, V_{OUT(T)}=Nominal Voltage

NOTE:

⁽¹⁾ Including hysteresis operating voltage range.

⁽²⁾ EFFI={ (output voltage × output current) / (input voltage × input current) } × 100

⁽³⁾ ON resistance (Ω)=(V_{IN} - Lx pin measurement voltage) / 100mA

⁽⁴⁾ Design value

⁽⁵⁾ When temperature is high, a current of approximately 10μA (maximum) may leak.

⁽⁶⁾ Time until it short-circuits V_{OUT} with GND via 1Ω of resistor from an operational state and is set to Lx=0V from current limit pulse generating.

⁽⁷⁾ When V_{IN} is less than 2.4V, limit current may not be reached because voltage falls caused by ON resistance.

⁽⁸⁾ When the difference between the input and the output is small, some cycles may be skipped completely before current maximizes.

If current is further pulled from this state, output voltage will decrease because of P-ch driver ON resistance.

⁽⁹⁾ Current limit denotes the level of detection at peak of coil current.

⁽¹⁰⁾ "H"=V_{IN}-V_{IN}-1.2V, "L"=+0.1V~-0.1V

⁽¹¹⁾ I_{PFM} and DTY_{LIMIT_PFM} are defined only for the XCL209 series.

ELECTRICAL CHARACTERISTICS (Continued)

2) XCL208Bxx3DR/XCL209Bxx3DR

Ta=25°C

| PARAMETER | SYMBOL | CONDITIONS | MIN. | TYP. | MAX. | UNIT | CIRCUIT |
|--|---|---|------------------|--------|--------|--------|---------|
| Output Voltage | V _{OUT} | V _{IN} =V _{CE} =5.0V, I _{OUT} =30mA | <E-1> | <E-2> | <E-3> | V | ① |
| Operating Voltage Range | V _{IN} | | 2.0 | - | 6.0 | V | ① |
| Maximum Output Current | I _{OUTMAX} | V _{IN} =V _{OUT(T)} +2.0V, V _{CE} =1.0V ⁽⁸⁾ | 400 | - | - | mA | ① |
| UVLO Voltage | V _{UVLO} | V _{CE} =V _{IN} , V _{OUT} =0V, Voltage which Lx pin holding "L" level ^{(1),(10)} | 1.00 | 1.40 | 1.78 | V | ③ |
| Supply Current (XCL208) | I _{DD} | V _{IN} =V _{CE} =5.0V, V _{OUT} =V _{OUT(T)} × 1.1V | - | 46 | 65 | μA | ② |
| Supply Current (XCL209) | | | - | 21 | 35 | | |
| Stand-by Current | I _{STB} | V _{IN} =5.0V, V _{CE} =0V, V _{OUT} =V _{OUT(T)} × 1.1V | - | 0 | 1 | μA | ② |
| Oscillation Frequency | f _{OSC} | V _{IN} =V _{OUT(T)} +2.0V, V _{CE} =1.0V, I _{OUT} =100mA | 2.55 | 3.00 | 3.45 | MHz | ① |
| PFM Switching Current ⁽¹¹⁾ | I _{PFM} | V _{IN} =V _{OUT(T)} +2.0V, V _{CE} =V _{IN} , I _{OUT} =1mA | <E-4> | <E-5> | <E-6> | mA | ⑩ |
| PFM Duty Limit ⁽¹¹⁾ | DTY _{LIMIT_PFM} | V _{CE} =V _{IN} =<C-1>, I _{OUT} =1mA | - | 200 | 300 | % | ① |
| Maximum Duty Cycle | D _{MAX} | V _{IN} =V _{CE} =5.0V, V _{OUT} =V _{OUT(T)} × 0.9V | 100 | - | - | % | ③ |
| Minimum Duty Cycle | D _{MIN} | V _{IN} =V _{CE} =5.0V, V _{OUT} =V _{OUT(T)} × 1.1V | - | - | 0 | % | ③ |
| Efficiency ⁽²⁾ | EFFI | V _{CE} =V _{IN} =V _{OUT(T)} +1.2V, I _{OUT} =100mA | - | <E-7> | - | % | ① |
| L _x SW "H" ON Resistance 1 | R _{LxH1} | V _{IN} =V _{CE} =5.0V, V _{OUT} =0V, I _{Lx} =100mA ⁽³⁾ | - | 0.35 | 0.55 | Ω | ④ |
| L _x SW "H" ON Resistance 2 | R _{LxH2} | V _{IN} =V _{CE} =3.6V, V _{OUT} =0V, I _{Lx} =100mA ⁽³⁾ | - | 0.42 | 0.67 | Ω | ④ |
| L _x SW "L" ON Resistance 1 | R _{LxL1} | V _{IN} =V _{CE} =5.0V ⁽⁴⁾ | - | 0.45 | 0.65 | Ω | - |
| L _x SW "L" ON Resistance 2 | R _{LxL2} | V _{IN} =V _{CE} =3.6V ⁽⁴⁾ | - | 0.52 | 0.77 | Ω | - |
| L _x SW "H" Leakage Current ⁽⁵⁾ | I _{LeakH} | V _{IN} =V _{OUT} =5.0V, V _{CE} =0V, V _{Lx} =0V | - | 0.01 | 1.00 | μA | ⑨ |
| Current Limit ⁽⁹⁾ | I _{LIM} | V _{IN} =V _{CE} =5.0V, V _{OUT} =V _{OUT(T)} × 0.9V ⁽⁷⁾ | 600 | 800 | 1000 | mA | ⑥ |
| Output Voltage Temperature Characteristics | $\frac{\Delta V_{OUT}}{V_{OUT} \cdot \Delta T_{opr}}$ | I _{OUT} =30mA, -40°C ≤ T _{opr} ≤ 85°C, | - | ±100 | - | ppm/°C | ① |
| CE "H" Voltage | V _{CEH} | V _{OUT} =0V, Applied voltage to V _{CE} Voltage changes Lx to "H" level ⁽¹⁰⁾ | 0.65 | - | 6.00 | V | ③ |
| CE "L" Voltage | V _{CEL} | V _{OUT} =0V, Applied voltage to V _{CE} Voltage changes Lx to "L" level ⁽¹⁰⁾ | AV _{SS} | - | 0.25 | V | ③ |
| CE "H" Current | I _{CEH} | V _{IN} =V _{CE} =5.0V, V _{OUT} =0V | -0.1 | - | 0.1 | μA | ⑤ |
| CE "L" Current | I _{CEL} | V _{IN} =5.0V, V _{CE} =0V, V _{OUT} =0V | -0.1 | - | 0.1 | μA | ⑤ |
| Soft-start Time | t _{SS} | V _{CE} =0V → V _{IN} , I _{OUT} =1mA | - | <E-11> | <E-12> | ms | ① |
| Latch Time | t _{LAT} | V _{IN} =V _{CE} =5.0V, V _{OUT} =0.8 × V _{OUT(T)} , Short Lx at 1Ω resistance ⁽⁶⁾ | 1 | - | 20 | ms | ⑦ |
| Short Protection Threshold Voltage | V _{SHORT} | Sweeping V _{OUT} , V _{IN} =V _{CE} =5.0V, Short Lx at 1Ω resistance, V _{OUT} voltage which Lx becomes "L" level within 1ms | <E-8> | <E-9> | <E-10> | V | ⑦ |
| CL Discharge | R _{DCHG} | V _{IN} =5.0V, L _x =5.0V, V _{CE} =0V, V _{OUT} =Open | 200 | 300 | 450 | Ω | ⑧ |
| Inductance Value | L | Test Frequency=1MHz | - | 1.5 | - | μH | - |
| Allowed Inductor Current | I _{DC} | ΔT=40°C | - | 700 | - | mA | - |

Test conditions: Unless otherwise stated, V_{IN}=5.0V, V_{OUT}(T)=Nominal Voltage

NOTE:

(1) Including hysteresis operating voltage range.

(2) EFFI={ (output voltage × output current) / (input voltage × input current) } × 100

(3) ON resistance (Ω)= (V_{IN} - Lx pin measurement voltage) / 100mA

(4) Design value

(5) When temperature is high, a current of approximately 10μA (maximum) may leak.

(6) Time until it short-circuits V_{OUT} with GND via 1Ω of resistor from an operational state and is set to Lx=0V from current limit pulse generating.

(7) When V_{IN} is less than 2.4V, limit current may not be reached because voltage falls caused by ON resistance.

(8) When the difference between the input and the output is small, some cycles may be skipped completely before current maximizes.

If current is further pulled from this state, output voltage will decrease because of P-ch driver ON resistance.

(9) Current limit denotes the level of detection at peak of coil current.

(10) "H"=V_{IN}-V_{IN}-1.2V, "L"=+0.1V~-0.1V

(11) IPFM and DTY_{LIMIT_PFM} are defined only for the XCL209 series.

■ ELECTRICAL CHARACTERISTICS (Continued)

3) XCL208F083DR/XCL209F083DR

Ta=25°C

| PARAMETER | SYMBOL | CONDITIONS | MIN. | TYP. | MAX. | UNIT | CIRCUIT |
|--|--|---|------------------|-------|-------|--------|---------|
| FB Voltage | V _{FB} | V _{IN} =V _{CE} =5.0V, V _{FB} voltage which Decrease V _{FB} from 0.9V, L _X becomes "H" ^(*) level | 0.784 | 0.800 | 0.816 | V | ③ |
| Operating Voltage Range | V _{IN} | | 1.8 | - | 6.0 | V | ① |
| Maximum Output Current | I _{OUTMAX} | V _{IN} =3.2V, V _{CE} =1.0V ^(*) | 400 | - | - | mA | ① |
| UVLO Voltage | V _{UVLO} | V _{CE} =V _{IN} , V _{FB} =0.4V, Voltage which L _X pin holding "L" level ^(*) , ^(*) | 1.00 | 1.40 | 1.78 | V | ③ |
| Supply Current (XCL208) | I _{DD} | V _{IN} =V _{CE} = 5.0V, V _{FB} =0.88V | - | 46 | 65 | μA | ② |
| Supply Current (XCL209) | | | - | 21 | 35 | | |
| Stand-by Current | I _{STB} | V _{IN} =5.0V, V _{CE} =0V, V _{FB} =0.88V | - | 0 | 1.0 | μA | ③ |
| Oscillation Frequency | f _{OSC} | V _{IN} =3.2V, V _{CE} =1.0V, I _{OUT} =100mA | 2.55 | 3.00 | 3.45 | MHz | ① |
| PFM Switching Current ^(*) | I _{PFM} | V _{IN} =3.2V, V _{CE} = V _{IN} , I _{OUT} =1mA | <E-4> | <E-5> | <E-6> | mA | ⑩ |
| PFM Duty Limit ^(*) | DTY _{LIMIT_PFM} | V _{IN} =V _{CE} =2.2V, I _{OUT} =1mA | - | 200 | 300 | % | ① |
| Maximum Duty Cycle | MAXDTY | V _{IN} =V _{CE} =5.0V, V _{FB} =0.72V | 100 | - | - | % | ③ |
| Minimum Duty Cycle | MINDTY | V _{IN} =V _{CE} =5.0V, V _{FB} =0.88V | - | - | 0 | % | ③ |
| Efficiency ⁽²⁾ | EFFI | V _{CE} =V _{IN} =2.4V, I _{OUT} =100mA | - | <E-7> | - | % | ① |
| L _X SW "H" ON Resistance 1 | R _{LXH1} | V _{IN} =V _{CE} =5.0V, V _{FB} =0.72V, I _{LX} =100mA ⁽³⁾ | - | 0.35 | 0.55 | Ω | ④ |
| L _X SW "H" ON Resistance 2 | R _{LXH2} | V _{IN} =V _{CE} =3.6V, V _{FB} =0.72V, I _{LX} =100mA ⁽³⁾ | - | 0.42 | 0.67 | Ω | ④ |
| L _X SW "L" ON Resistance 1 | R _{LXL1} | V _{IN} =V _{CE} =5.0V ⁽⁴⁾ | - | 0.45 | 0.65 | Ω | - |
| L _X SW "L" ON Resistance 2 | R _{LXL2} | V _{IN} =V _{CE} =3.6V ⁽⁴⁾ | - | 0.52 | 0.77 | Ω | - |
| LX SW "H" Leakage Current ⁽⁵⁾ | I _{leakH} | V _{IN} =V _{FB} =5.0V, V _{CE} =0V, L _X =0V | - | 0.01 | 1.00 | μA | ⑨ |
| Current Limit ⁽⁹⁾ | I _{LIM} | V _{IN} =V _{CE} =5.0V, V _{FB} =0.72V ⁽⁷⁾ | 600 | 800 | 1000 | mA | ⑥ |
| Output Voltage Temperature Characteristics | ΔV _{OUT} / (V _{OUT} ·ΔT _{opr}) | I _{OUT} =30mA, -40°C ≤ T _{opr} ≤ 85°C, | - | ±100 | - | ppm/°C | ① |
| CE "H" Voltage | V _{CEH} | V _{FB} =0.72V, Applied voltage to V _{CE} , Voltage changes L _X to "H" level ^(*) | 0.65 | - | 6.00 | V | ③ |
| CE "L" Voltage | V _{CEL} | V _{FB} =0.72V, Applied voltage to V _{CE} , Voltage changes L _X to "L" level ^(*) | AV _{SS} | - | 0.25 | V | ③ |
| CE "H" Current | I _{CEH} | V _{IN} =V _{CE} =5.0V, V _{FB} =0.72V | -0.1 | - | 0.1 | μA | ⑤ |
| CE "L" Current | I _{CEL} | V _{IN} =5.0V, V _{CE} =0V, V _{FB} =0.72V | -0.1 | - | 0.1 | μA | ⑤ |
| Soft-start Time | t _{SS} | When connected to external components, V _{CE} =0V → V _{IN} , I _{OUT} =1mA | - | 0.25 | 0.40 | ms | ① |
| Latch Time | t _{LAT} | V _{IN} =V _{CE} =5.0V, V _{FB} =0.64V, Short L _X at 1Ω resistance ⁽⁶⁾ | 1 | - | 20 | ms | ⑦ |
| Short Protection Threshold Voltage | V _{SHORT} | V _{IN} =V _{CE} =5.0V, V _{FB} voltage which Decrease V _{FB} from 0.4V, L _X becomes "L" ^(*) level | 0.150 | 0.200 | 0.250 | V | ⑦ |
| C _L Discharge | R _{DCHG} | V _{IN} =5.0V, L _X =5.0V, V _{CE} =0V, V _{FB} =Open | 200 | 300 | 450 | Ω | ⑧ |
| Inductance Value | L | Test Frequency=1MHz | - | 1.5 | - | μH | - |
| Allowed Inductor Current | I _{DC} | ΔT=40°C | - | 700 | - | mA | - |

V_{OUT(T)}=Nominal Voltage

Test conditions: Unless otherwise stated, V_{IN}=5.0V, V_{OUT}=1.2V, and the order of voltage application is V_{FB}→V_{IN}→V_{CE}

NOTE:

⁽¹⁾ Including hysteresis operating voltage range.

⁽²⁾ EFFI = { (output voltage × output current) / (input voltage × input current) } × 100

⁽³⁾ ON resistance (Ω) = (V_{IN} - L_X pin measurement voltage) / 100mA

⁽⁴⁾ Design value

⁽⁵⁾ When temperature is high, a current of approximately 10μA (maximum) may leak.

⁽⁶⁾ Time until it short-circuits V_{OUT} with GND via 1Ω of resistor from an operational state and is set to L_X=0V from current limit pulse generating.

⁽⁷⁾ When V_{IN} is less than 2.4V, limit current may not be reached because voltage falls caused by ON resistance.

⁽⁸⁾ When the difference between the input and the output is small, some cycles may be skipped completely before current maximizes.

If current is further pulled from this state, output voltage will decrease because of P-ch driver ON resistance.

⁽⁹⁾ Current limit denotes the level of detection at peak of coil current.

⁽¹⁰⁾ "H"=V_{IN}-V_{IN}-1.2V, "L"=+0.1V~-0.1V

⁽¹¹⁾ IPFM and DTY_{LIMIT_PFM} are defined only for the XCL209 series.

ELECTRICAL CHARACTERISTICS (Continued)

| V _{OUT} | PFM Duty V _{IN} (V) | V _{OUT} (V) | | | I _{PFM} (mA) | | | EFFI (%) | V _{SHORT} (ms) | | | t _{ss} (ms) | |
|------------------|------------------------------|----------------------|-------|-------|-----------------------|-------|-------|----------|-------------------------|-------|-------|----------------------|--------|
| | | MIN. | TYP. | MAX. | MIN. | TYP. | MAX. | TYP. | MIN. | TYP. | MAX. | TYP. | MAX. |
| | | <C-1> | <E-1> | <E-2> | <E-3> | <E-4> | <E-5> | <E-6> | <E-7> | <E-8> | <E-9> | <E-10> | <E-11> |
| 1.00 | 2.0V | 0.980 | 1.000 | 1.020 | 190 | 260 | 350 | 79 | 0.375 | 0.500 | 0.625 | 0.25 | 0.40 |
| 1.20 | 2.20 | 1.176 | 1.200 | 1.224 | 190 | 260 | 350 | 82 | 0.450 | 0.600 | 0.750 | 0.25 | 0.40 |
| 1.50 | 2.50 | 1.470 | 1.500 | 1.530 | 180 | 240 | 300 | 84 | 0.563 | 0.750 | 0.938 | 0.25 | 0.40 |
| 1.80 | 2.80 | 1.764 | 1.800 | 1.836 | 170 | 220 | 270 | 85 | 0.675 | 0.900 | 1.125 | 0.32 | 0.50 |
| 2.50 | 3.50 | 2.450 | 2.500 | 2.550 | 170 | 220 | 270 | 86 | 0.938 | 1.250 | 1.563 | 0.32 | 0.50 |
| 2.80 | 3.80 | 2.744 | 2.800 | 2.856 | 170 | 220 | 270 | 86 | 1.050 | 1.400 | 1.750 | 0.32 | 0.50 |
| 2.85 | 3.85 | 2.793 | 2.850 | 2.907 | 170 | 220 | 270 | 86 | 1.069 | 1.425 | 1.781 | 0.32 | 0.50 |
| 3.00 | 4.00 | 2.940 | 3.000 | 3.060 | 170 | 220 | 270 | 86 | 1.125 | 1.500 | 1.875 | 0.32 | 0.50 |
| 3.30 | 4.30 | 3.234 | 3.300 | 3.366 | 170 | 220 | 270 | 86 | 1.238 | 1.650 | 2.063 | 0.32 | 0.50 |

<XCL208/XCL209 F type output voltage setting>

The output voltage can be set by adding external dividing resistors. The output voltage is determined by R1 and R2 in the equation below. The sum of R1 and R2 is normally kept 1MΩ or less. The output voltage range can be set from 0.9V to 6.0V based on the 0.8V ±2.0% reference voltage source.

Note that when the input voltage (V_{IN}) is less than or equal to the set output voltage, an output voltage (V_{OUT}) higher than the input voltage (V_{IN}) cannot be output.

$$V_{OUT} = 0.8 \times (R1 + R2) / R2$$

Adjust the value of the phase compensation speedup capacitor C_{FB} so that f_{zfb} = 1 / (2 × π × C_{FB} × R1) is 10kHz or less. It is optimum to adjust to a value from 1kHz to 20kHz based on the components used and the board layout.

[Calculation example]

When R1=470kΩ, R2=150kΩ, V_{OUT}=0.8×(470k+150k)/150k=3.3V

e.g.

| V _{OUT} (V) | R1 (kΩ) | R2 (kΩ) | C _{FB} (pF) |
|----------------------|---------|---------|----------------------|
| 0.9 | 100 | 820 | 150 |
| 1.2 | 150 | 300 | 100 |
| 1.5 | 130 | 150 | 220 |
| 1.8 | 300 | 240 | 150 |
| 2.5 | 510 | 240 | 100 |
| 3.0 | 330 | 120 | 150 |
| 3.3 | 470 | 150 | 100 |
| 4.0 | 120 | 30 | 470 |

Circuit (XCL208F/XCL209F Type)

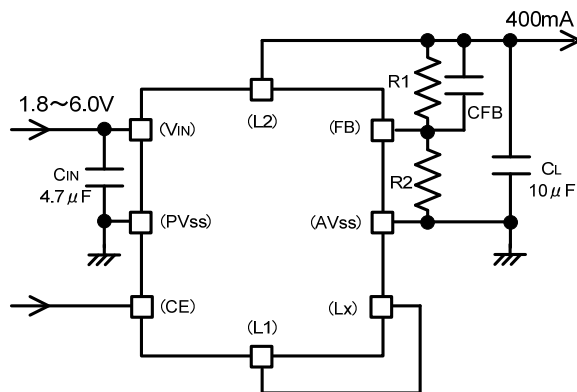

TEST CIRCUITS

< Circuit No.① >
XCL208/XCL209 A/B Type

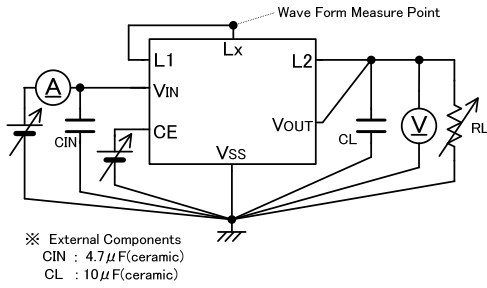

< Circuit No.② >

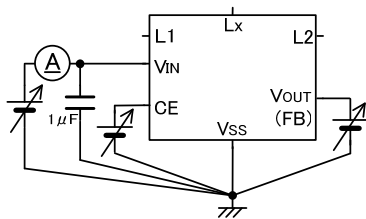

< Circuit No.④ >

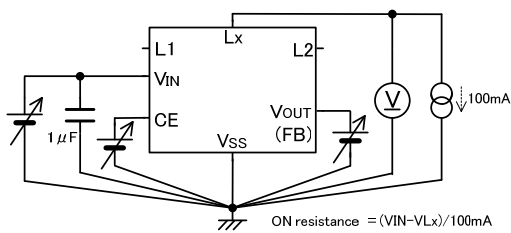

< Circuit No.⑥ >

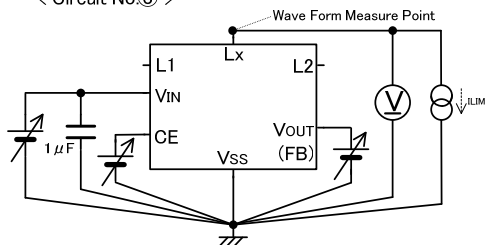

< Circuit No.⑧ >

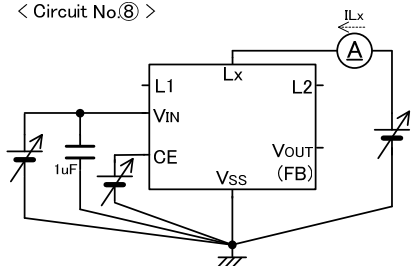

< Circuit No.⑩ >
XCL208/XCL209 A/B Type

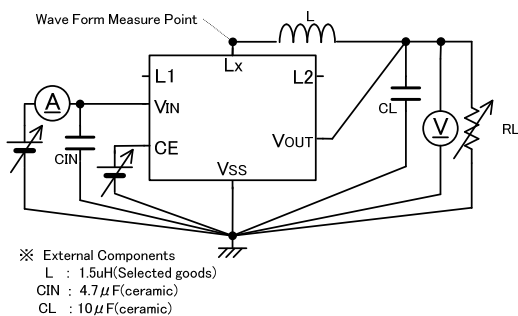

< Circuit No.① >
XCL208/XCL209 F Type

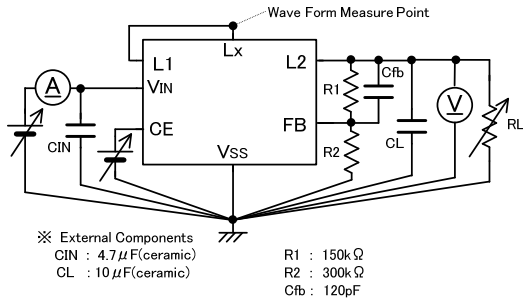

< Circuit No.③ >

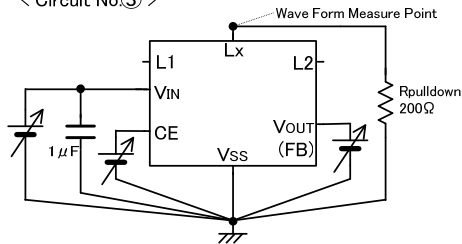

< Circuit No.⑤ >

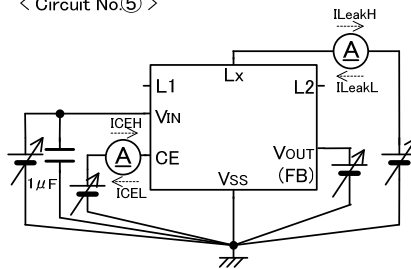

< Circuit No.⑦ >

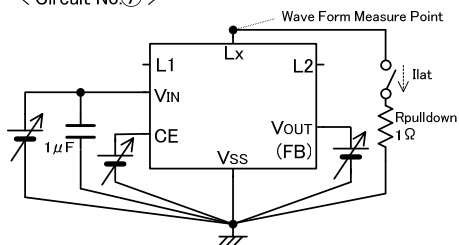

< Circuit No.⑨ >

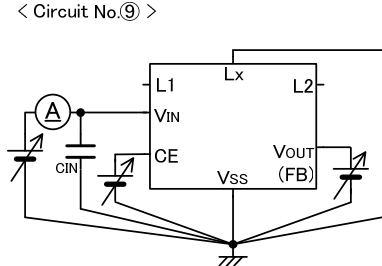

< Circuit No.⑩ >
XCL208/XCL209 F Type

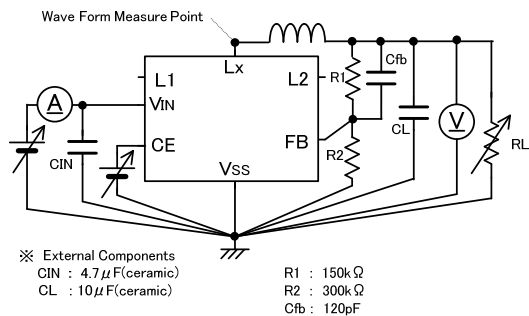

OPERATIONAL DESCRIPTION

The XCL208/XCL209 series consists of a reference voltage source, ramp wave circuit, error amplifier, PWM comparator, phase compensation circuit, output voltage adjustment resistors, P-ch MOSFET driver transistor, N-ch MOSFET switching transistor for the synchronous switch, current limiter circuit, UVLO circuit with control IC, and an inductor. (See the block diagram below.) Using the error amplifier, the voltage of the internal voltage reference source is compared with the feedback voltage from the V_{OUT} pin through split resistors, R1 and R2. Phase compensation is performed on the resulting error amplifier output, to input a signal to the PWM comparator to determine the turn-on time during PWM operation. The PWM comparator compares, in terms of voltage level, the signal from the error amplifier with the ramp wave from the ramp wave circuit, and delivers the resulting output to the buffer driver circuit to cause the Lx pin to output a switching duty cycle. This process is continuously performed to ensure stable output voltage. The current feedback circuit monitors the P-ch MOS driver transistor current for each switching operation, and modulates the error amplifier output signal to provide multiple feedback signals. This enables a stable feedback loop even when a low ESR capacitor such as a ceramic capacitor is used ensuring stable output voltage.

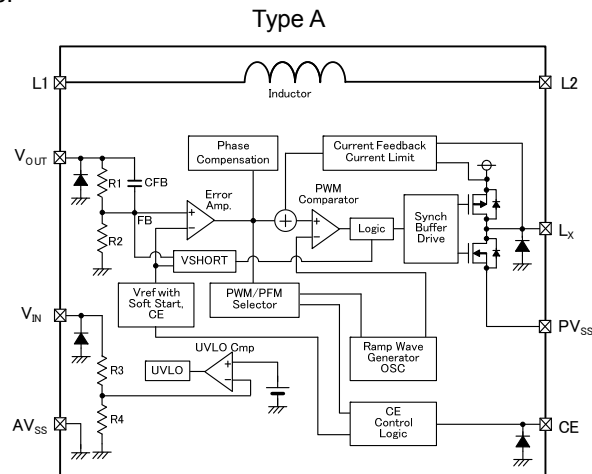

<Reference Voltage Source>

The reference voltage source provides the reference voltage to ensure stable output voltage of the DC/DC converter.

<Ramp Wave Circuit>

The ramp wave circuit determines switching frequency. The frequency is fixed internally 3.0MHz. Clock pulses generated in this circuit are used to produce ramp waveforms needed for PWM operation, and to synchronize all the internal circuits.

<Error Amplifier>

The error amplifier is designed to monitor output voltage. The amplifier compares the reference voltage with the feedback (Type F: FB pin voltage) divided by the internal split resistors, R1 and R2. When a feedback voltage is lower than the reference voltage, the output voltage of the error amplifier is increased. The gain and frequency characteristics of the error amplifier output are fixed internally to deliver an optimized signal to the mixer.

<Current Limit>

The current limiter circuit of the XCL208/XCL209 series monitors the current flowing through the P-ch MOS driver transistor connected to the Lx pin, and features a combination of the current limit mode and the operation suspension mode.

- ① When the driver current is greater than a current limit level, the current limit function operates to turn off the pulses from the Lx pin at any given timing.
- ② When the driver transistor is turned off, the limiter circuit is then released from the current limit detection state.
- ③ At the next pulse, the driver transistor is turned on. However, the transistor is immediately turned off in the case of an over current state.
- ④ When the over current state is eliminated, the IC resumes its normal operation.

The IC waits for the over current state to end by repeating the steps ① through ③. If an over current state continues for a latch time and the above three steps are repeatedly performed, the IC performs the function of latching the OFF state of the driver transistor, and goes into operation suspension state. Once the IC is in suspension state, operations can be resumed by either turning the IC off via the CE pin, or by restoring power to the V_{IN} pin. The suspension state does not mean a complete shutdown, but a state in which pulse output is suspended; therefore, the internal circuitry remains in operation. The current limit of the XCL208/XCL209 series can be set at 800mA at typical. Depending on the state of the PC Board, latch time may become longer and latch operation may not work. In order to avoid the effect of noise, an input capacitor is placed as close to the IC as possible.

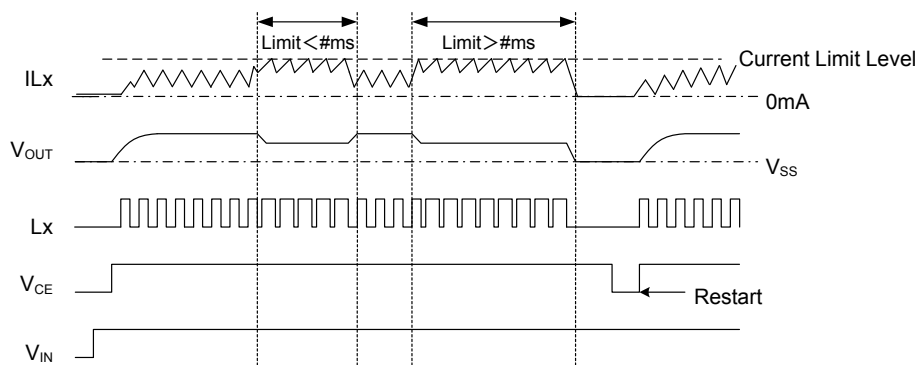

OPERATIONAL DESCRIPTION(Continued)

<Short-Circuit Protection>

The short-circuit protection circuit monitors the internal R1 and R2 divider voltage (Type F: FB pin voltage). In case where output is accidentally shorted to the Ground and when the FB point voltage decreases less than half of the reference voltage (Vref) and a current more than the I_{LIM} flows to the driver transistor, the short-circuit protection quickly operates to turn off and to latch the driver transistor. In the latch state, the operation can be resumed by either turning the IC off and on via the CE pin, or by restoring power supply to the V_{IN} pin.

Also, when sharp load transient happens, a voltage drop at the V_{OUT} is propagated through C_{FB}, as a result, short circuit protection may operate in the voltage higher than short-circuit protection voltage.

<UVLO Circuit>

When the V_{IN} pin voltage becomes 1.4V (TYP.) or lower, the P-channel output driver transistor is forced OFF to prevent false pulse output caused by unstable operation of the internal circuitry. When the V_{IN} pin voltage becomes 1.8V or higher, by releasing the UVLO state then the soft-start function initiates output startup operation. The soft-start function operates even when the V_{IN} pin voltage falls momentarily below the UVLO operating voltage same as releasing the UVLO function. The UVLO circuit does not cause a complete shutdown of the IC, but causes pulse output to be suspended; therefore, the internal circuitry remains in operation.

<PFM Switch Current>

In PFM control operation, until coil current reaches to I_{PFM}, the IC keeps the P-ch MOSFET on. In this case, on-time (t_{ON}) that the P-ch MOSFET is kept on can be given by the following formula.

$$t_{ON} = L \times I_{PFM} / (V_{IN} - V_{OUT}) \rightarrow I_{PFM} \textcircled{1}$$

<PFM Duty Limit>

In the PFM control operation, the maximum PFM Duty Limit is set to 200% (TYP.). Therefore, under the condition that the step-down ratio is small, it's possible for P-ch MOSFET to be turned off even when coil current doesn't reach to I_{PFM}. → I_{PFM} ②

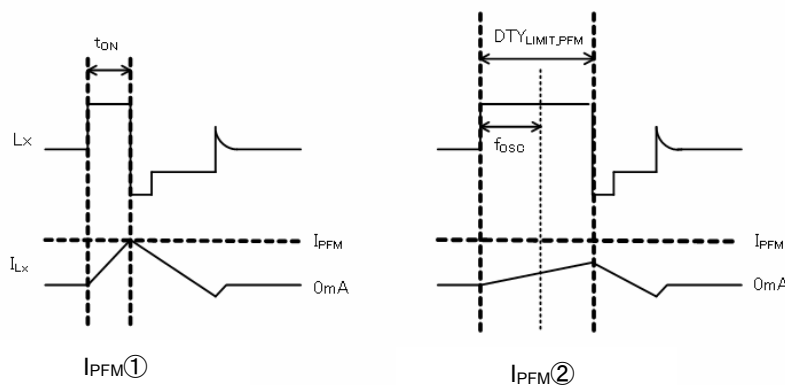

<CL High Speed Discharge>

The XCL208B/XCL209B and the XCL208F/XCL209F can quickly discharge the electric charge at the output capacitor (C_L) when a low signal to the CE pin which enables a whole IC circuit put into OFF state, is inputted via the N-ch transistor located between the L_x pin and the V_{SS} pin. When the IC is disabled, electric charge left at the output capacitor (C_L) is quickly discharged so that it may avoid application malfunction. Discharge time is set by the C_L auto-discharge resistance (R_{DCHG}) and the output capacitance (C_L). By setting time constant as τ ($\tau = C_L \times R_{DCHG}$), discharge time of the output voltage is calculated by the following formula.

$$V = V_{OUT(T)} \times e^{-t/\tau} \text{ or } t = \tau \ln (V_{OUT(T)} / V)$$

V : Output voltage after discharge
V_{OUT(T)} : Output voltage
t: Discharge time,
 τ : C_L × R_{DCHG}
C_L : Output capacitance (C_L)
R_{DCHG} : C_L auto-discharge resistance

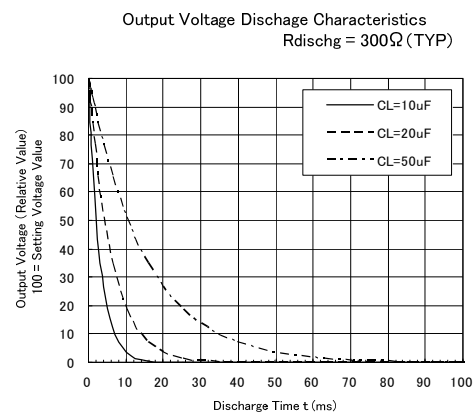

OPERATIONAL DESCRIPTION(Continued)

<CE Pin Function>

The operation of the XCL208/XCL209 series will enter into the stand-by mode when a low level signal is input to the CE pin. During the stand-by mode, the current consumption of the IC becomes $0\mu\text{A}$ (TYP.), with a state of high impedance at the Lx pin and V_{OUT} pin. The IC starts its operation by inputting a high level signal to the CE pin. The input to the CE pin is a CMOS input and the sink current is $0\mu\text{A}$ (TYP.).

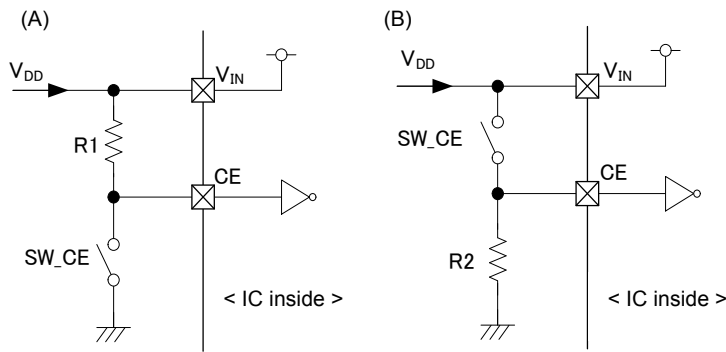

(A)

| SW_CE | OPERATIONAL STATES |
|-------|--------------------|
| ON | Stand-by |
| OFF | Active |

(B)

| SW_CE | OPERATIONAL STATES |
|-------|--------------------|
| ON | Active |
| OFF | Stand-by |

<Soft-Start>

Soft-start time is internally set. Soft-start time is defined as the time to reach 90% of the output nominal voltage when the CE pin is turned on.

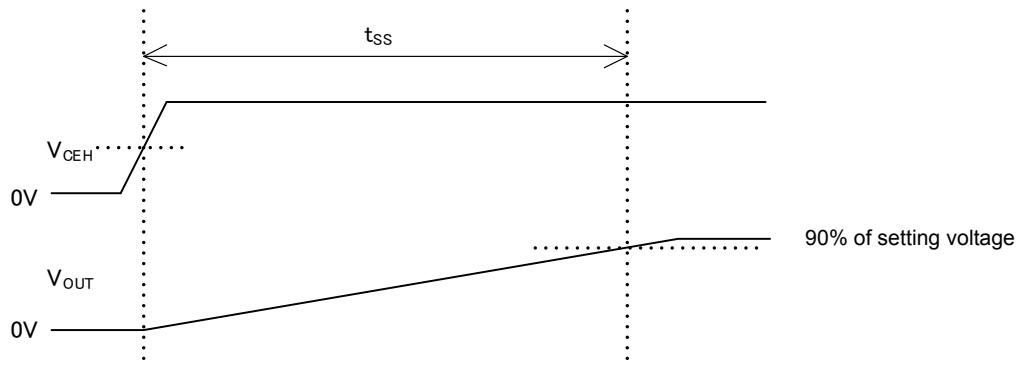

NOTE ON USE

- For temporary, transitional voltage drop or voltage rising phenomenon, the IC is liable to malfunction should the ratings be exceeded.
- The XCL208/XCL209 series is designed for use with ceramic output capacitors. If, however, the potential difference is too large between the input voltage and the output voltage, a ceramic capacitor may fail to absorb the resulting high switching energy and oscillation could occur on the output. In this case, increase 10 μ F to the output capacitance for adding insufficient capacitance. Also, if the output capacitance is too large, the output voltage is slowly rising and the IC may not operate. Adjust the output capacitance so that the output voltage can go up within the soft-start time.
- Spike noise and ripple voltage arise in a switching regulator as with a DC/DC converter. These are greatly influenced by external component selection, such as the coil inductance, capacitance values, and board layout of external components. Once the design has been completed, verification with actual components should be done.
- Depending on the input-output voltage differential, or load current, some pulses may be skipped as 1/2, 1/3 and the ripple voltage may increase.
- When the difference between input and output is large in PWM control, very narrow pulses will be outputted, and there is the possibility that 0% duty cycles may be continued during some cycles.
- When the difference between input and output is small, and the load current is heavy, very wide pulses will be outputted and there is the possibility that 100% duty cycles may be continued during some cycles.
- With the IC, the peak current of the coil is controlled by the current limit circuit. Since the peak current of the coil increases when dropout voltage or load current is high, current limit starts operation, and this can lead to instability. When peak current becomes high, please adjust the coil inductance value and fully check the circuit operation. In addition, please calculate the peak current according to the following formula:

$$I_{pk} = (V_{IN} - V_{OUT}) \times OnDuty / (2 \times L \times f_{osc}) + I_{OUT}$$

L: Coil Inductance Value
 f_{osc} : Oscillation Frequency
- When the peak current which exceeds limit current flows within the specified time, the built-in P-ch driver transistor turns off. During the time until it detects limit current and before the built-in transistor can be turned off, the current for limit current flows; therefore, care must be taken when selecting the rating for the external components such as a coil.
- When V_{IN} is less than 2.4V, limit current may not be reached because voltage falls caused by ON resistance.
- Depending on the state of the PC Board, latch time may become longer and latch operation may not work. In order to avoid the effect of noise, the board should be laid out so that input capacitors are placed as close to the IC as possible.
- Use of the IC at voltages below the minimum operating voltage range may lead to instability.
- This IC should be used within the stated absolute maximum ratings of external components in order to prevent damage to the device.
- When the IC is used in high temperature, output voltage may increase up to input voltage level at no load because of the leak current of the driver transistor.
- The current limit is set to 1000mA (MAX.) at typical. However, the current of 1000mA or more may flow. In case that the current limit functions while the V_{OUT} pin is shorted to the GND pin, when P-ch MOSFET is ON, the potential difference for input voltage will occur at both ends of a coil. For this, the time rate of coil current becomes large. By contrast, when N-ch MOSFET is ON, there is almost no potential difference at both ends of the coil since the V_{OUT} pin is shorted to the GND pin. Consequently, the time rate of coil current becomes quite small. According to the repetition of this operation, and the delay time of the circuit, coil current will be converged on a certain current value, exceeding the amount of current, which is supposed to be limited originally. Even in this case, however, after the over current state continues for several ms, the circuit will be latched. A coil should be used within the stated absolute maximum rating in order to prevent damage to the device.
 - Current flows into P-ch MOSFET to reach the current limit (I_{LIM}).
 - The current of I_{LIM} or more flows since the delay time of the circuit occurs during from the detection of the current limit to OFF of P-ch MOSFET.
 - Because of no potential difference at both ends of the coil, the time rate of coil current becomes quite small.
 - I_{Lx} oscillates very narrow pulses by the current limit for several ms.
 - The circuit is latched, stopping its operation.

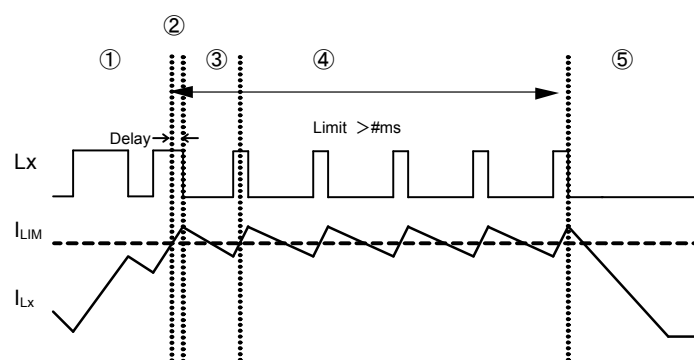

NOTE ON USE (Continued)

15. In order to stabilize V_{IN} voltage level and oscillation frequency, we recommend that a by-pass capacitor (C_{IN}) be connected as close as possible to the V_{IN} & V_{SS} pins.
16. High step-down ratio and very light load may lead an intermittent oscillation when PWM mode.
17. For the XCL209, when PWM/PFM automatic switching goes into continuous mode, the IC may be in unstable operation for the range of MAXDUTY area with small input/output differential. Once the design has been completed, verification with actual components should be done.
18. Torex places an importance on improving our products and their reliability. We request that users incorporate fail-safe designs and post-aging protection treatment when using Torex products in their systems.
19. Instructions of pattern layouts
 - (1) In order to stabilize V_{IN} voltage level, we recommend that a by-pass capacitor (C_{IN}) be connected as close as possible to the V_{IN} (No.8) and PV_{SS} (No.1) pins.
 - (2) Please mount each external component as close to the IC as possible.
 - (3) Wire external components as close to the IC as possible and use thick, short connecting traces to reduce the circuit impedance.
 - (4) Make sure that the PCB GND traces are as thick as possible, as variations in ground potential caused by high ground currents at the time of switching may result in instability of the IC.
 - (5) Internal driver transistors bring on heat because of the output current and ON resistance of the driver transistors.
 - (6) Please connect Lx (No.2) pin and L1 (No.9) pin on the PCB layout.
 - (7) Please connect V_{OUT} (No.4) pin and L2 (No.10) pin on the PCB layout. (Type A/B)

<Type A/B (V_{OUT})>

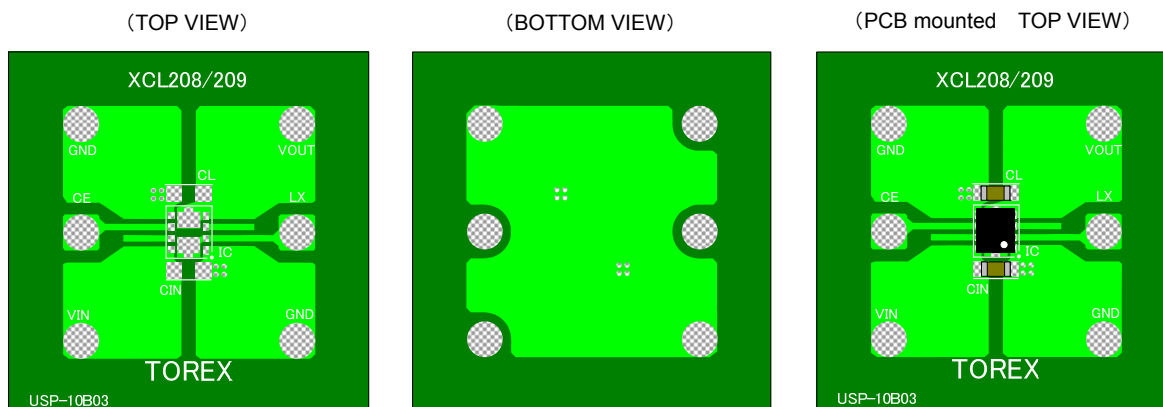

<Type F (FB)>

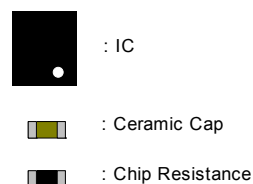
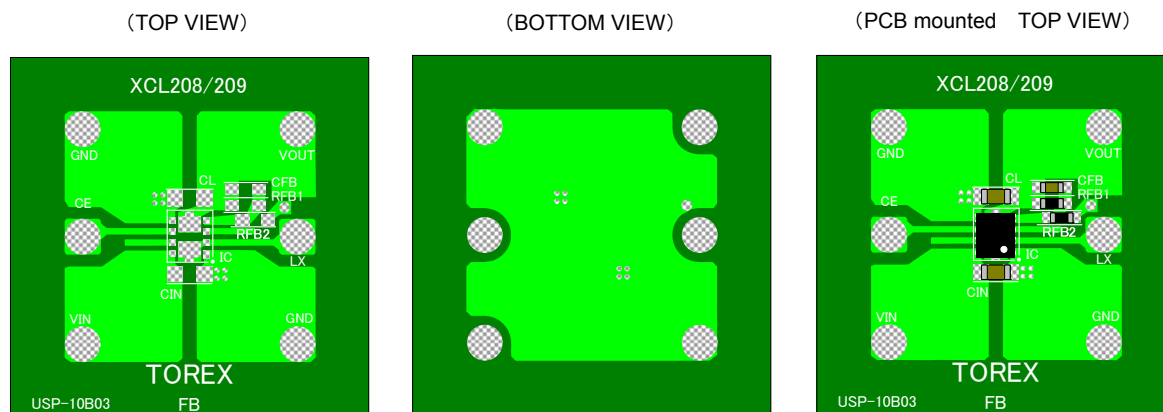

NOTE ON USE (Continued)

20. Typical application circuit

<Typical application circuits Type A/B>

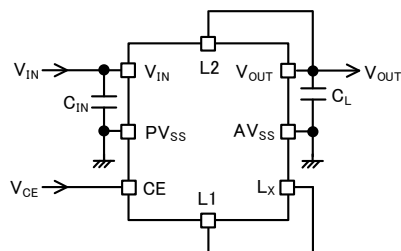

Example of external components

C_{IN} : 10V/4.7 μ F (LMK107BJ475KA TAIYO YUDEN)
 C_L : 10V/10 μ F (LMK107BBJ106MA TAIYO YUDEN)

< Typical application circuits Type F >

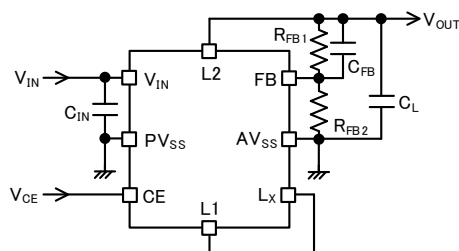

Example of external components ($V_{OUT}=1.8V$)

C_{IN} : 10V/4.7 μ F (LMK107BJ475KA TAIYO YUDEN)
 C_L : 10V/10 μ F (LMK107BBJ106MA TAIYO YUDEN)
 R_{FB1} : 300k Ω
 R_{FB2} : 240k Ω
 C_{FB} : 150pF (C1005CH1H151J TDK)

NOTE:

The integrated Inductor can be used only for this DC/DC converter. Please do not use this inductor for other reasons.
 Please use B, X5R, and X7R grades in temperature characteristics for the C_{IN} and C_L capacitors.
 These grade ceramic capacitors minimize capacitance-loss as a function of voltage stress.
 If necessary, increase capacitance by adding or replacing.

Examples of external components

| | PART NUMBER | MANUFACTURE | RATED VOLTAGE / INDUCTANCE / FEATURES | Size (L×W) |
|----------|----------------|-------------|---------------------------------------|--------------|
| C_{IN} | LMK107BJ475KA | TAIYO YUDEN | 10V/4.7 μ F/X5R | 1.6mm×0.8mm |
| | LMK212B7475KG | TAIYO YUDEN | 10V/4.7 μ F/X7R | 2.0mm×1.25mm |
| C_L | LMK107BBJ106MA | TAIYO YUDEN | 10V/10 μ F/X5R | 1.6mm×0.8mm |
| | LMK212B7106MG | TAIYO YUDEN | 10V/4.7 μ F/X7R | 2.0mm×1.25mm |

TYPICAL PERFORMANCE CHARACTERISTICS

(1) Efficiency vs. Output Current

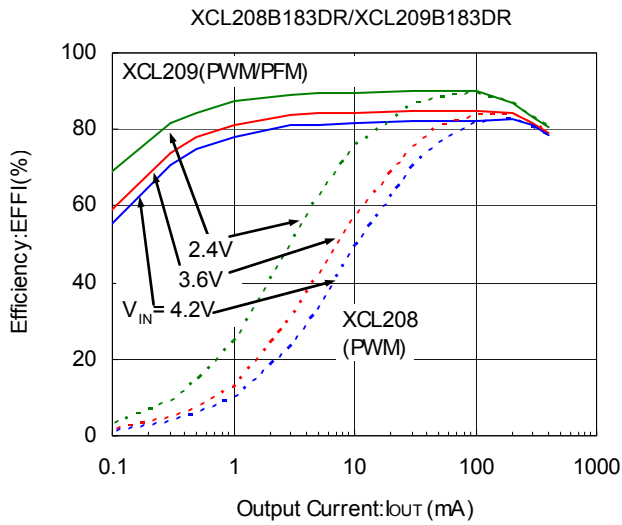

(2) Output Voltage vs. Output Current

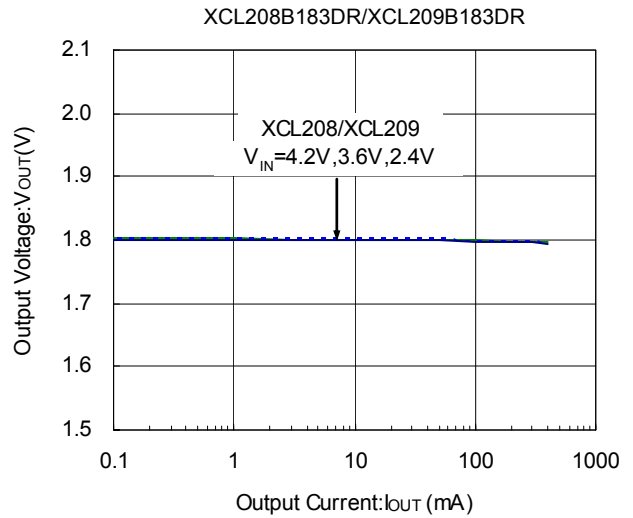

(3) Ripple Voltage vs. Output Current

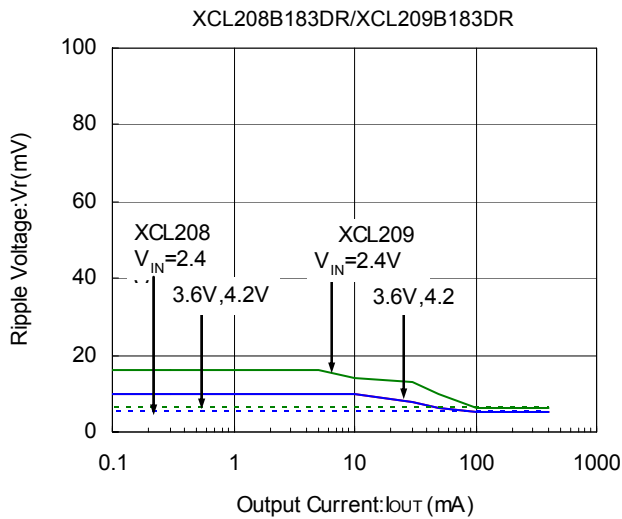

(4) Oscillation Frequency vs. Ambient Temperature

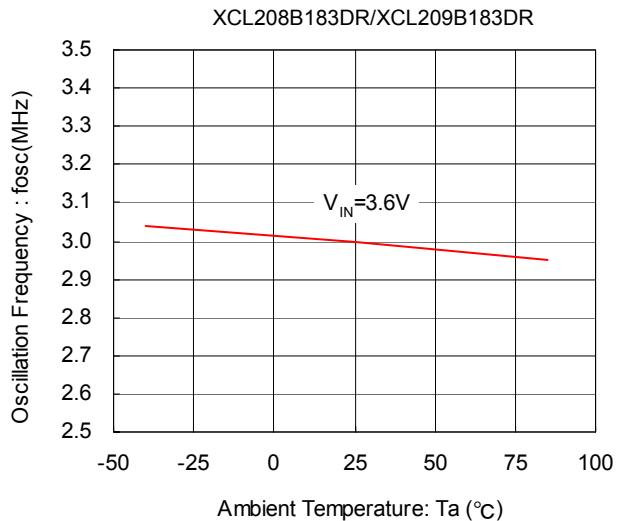

(5) Supply Current vs. Ambient Temperature

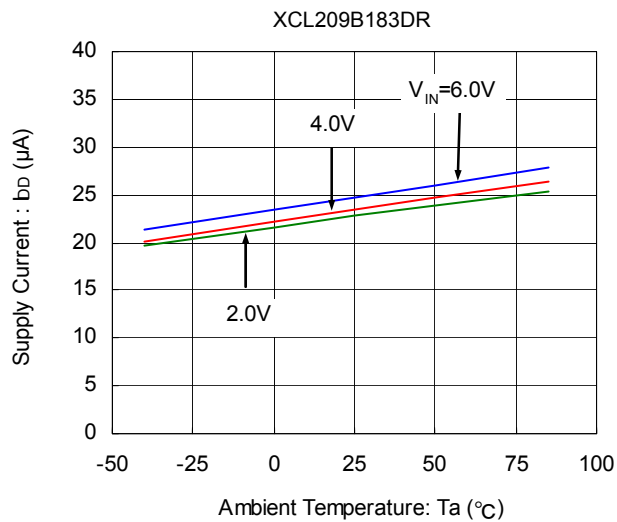

(6) Output Voltage vs. Ambient Temperature

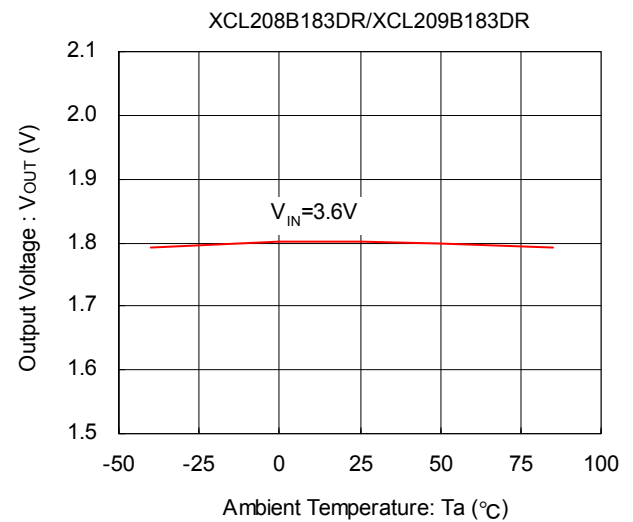

TYPICAL PERFORMANCE CHARACTERISTICS (Continued)

(7) UVLO Voltage vs. Ambient Temperature

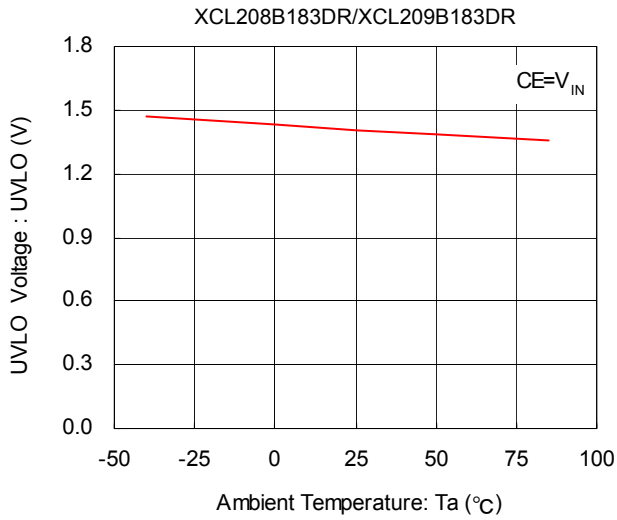

(8) CE "H" Voltage vs. Ambient Temperature

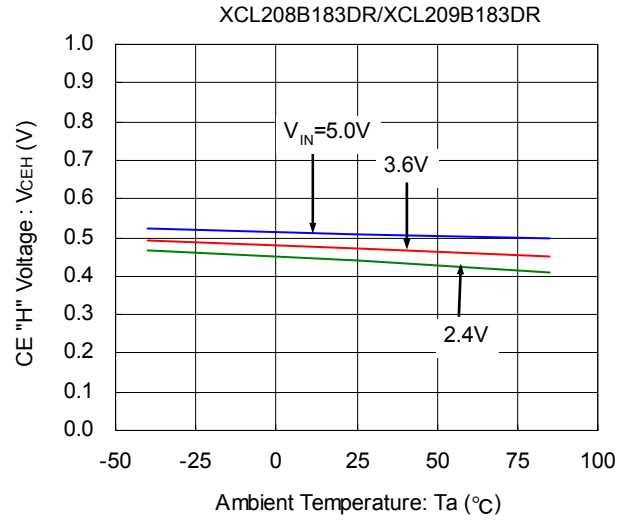

(9) CE "L" Voltage vs. Ambient Temperature

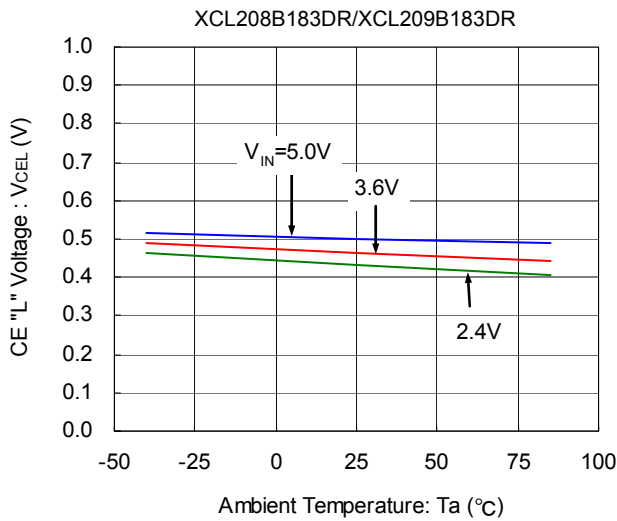

(10) Soft Start Time vs. Ambient Temperature

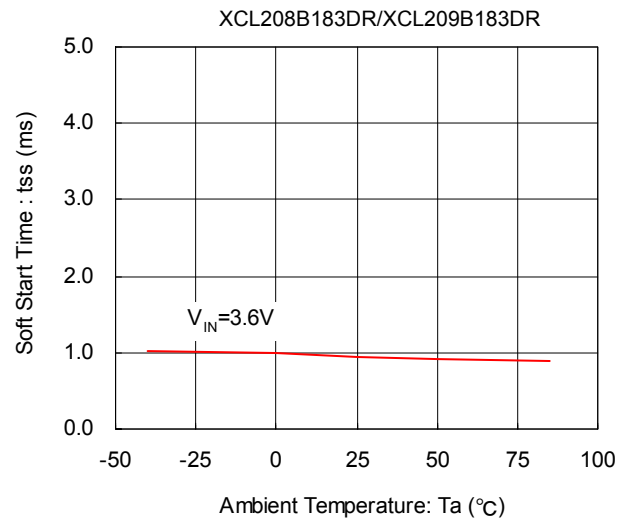

(11) "Pch / Nch" Driver on Resistance vs. Input Voltage

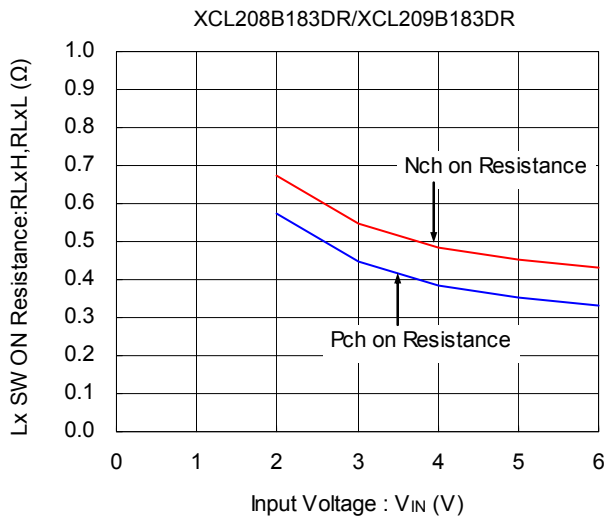

(12) Rise Wave Form

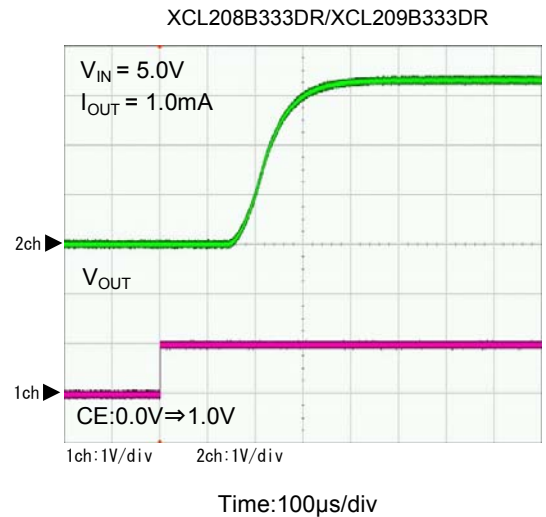

TYPICAL PERFORMANCE CHARACTERISTICS (Continued)

(13) Soft-Start Time vs. Ambient Temperature

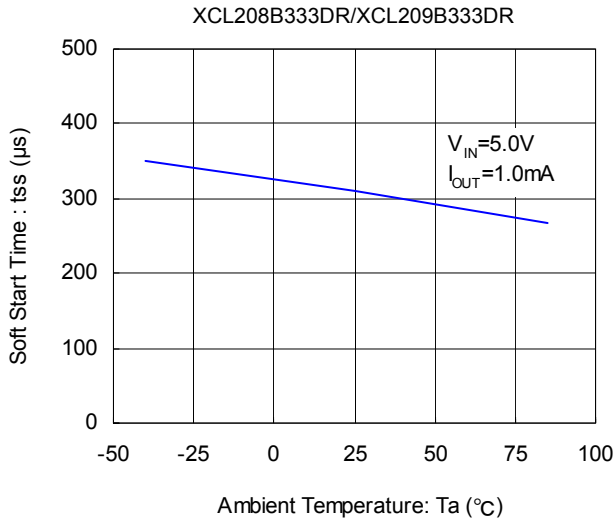

(14) CL Discharge Resistance vs. Ambient Temperature

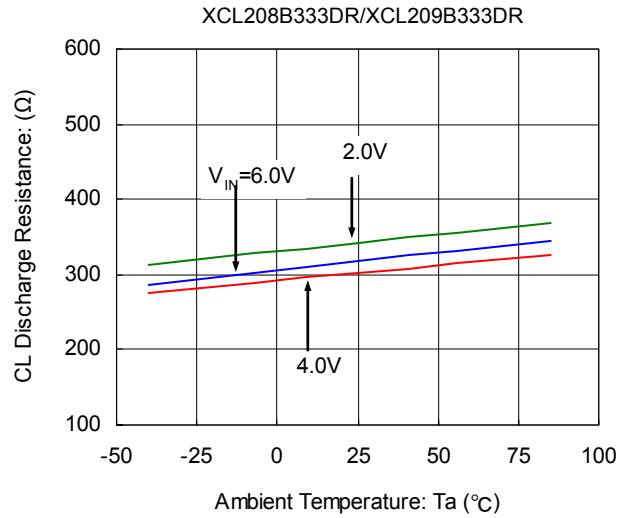

(15) Load Transient Response

MODE : PWM/PFM Automatic Switching Control

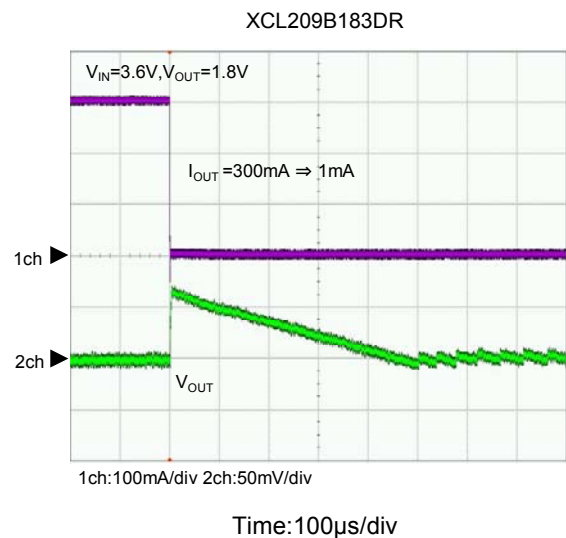
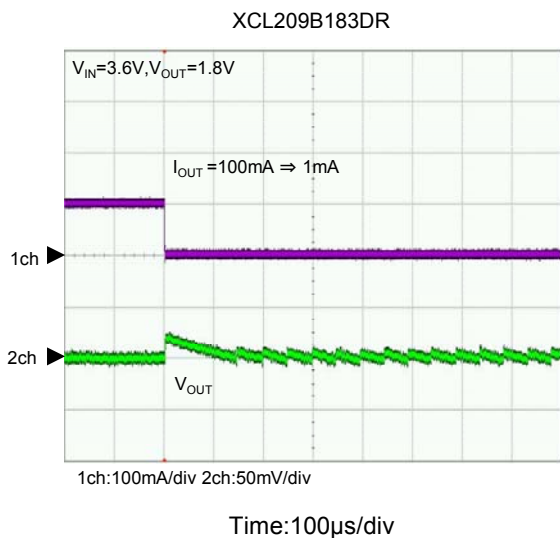
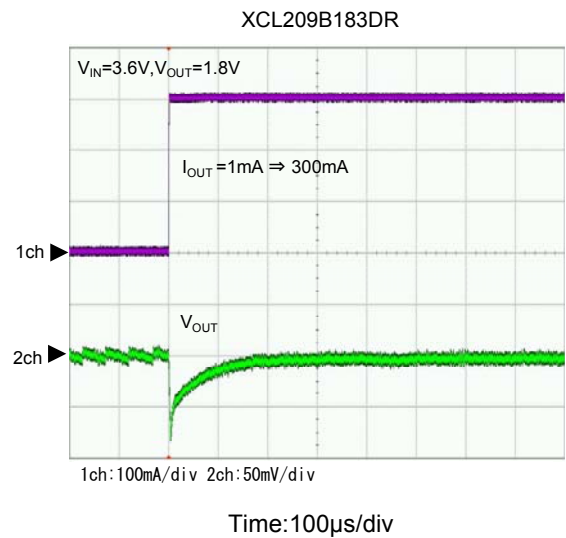
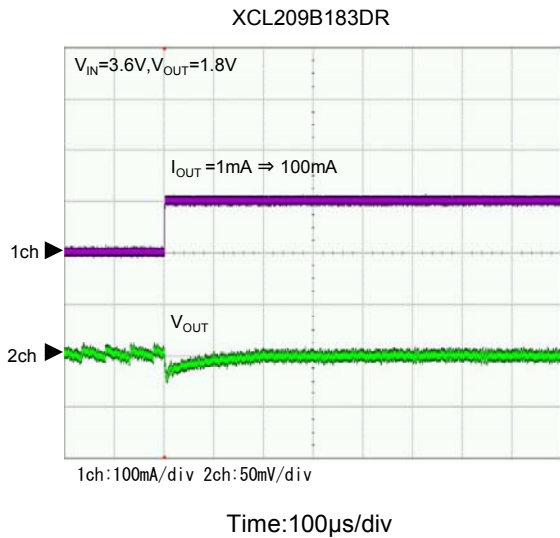

TYPICAL PERFORMANCE CHARACTERISTICS (Continued)

(15) Load Transient Response (Continued)

MODE : PWM Control

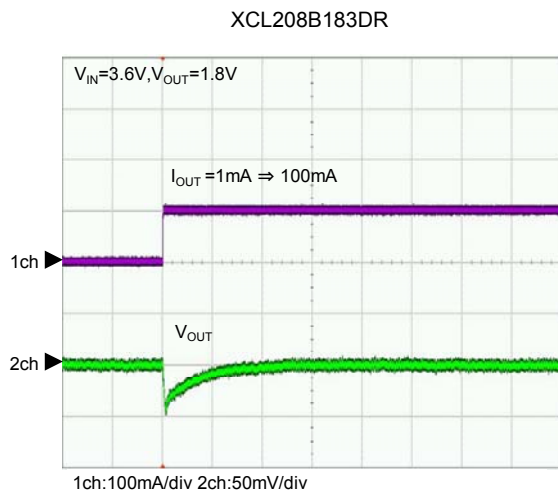

Time:100 μ s/div

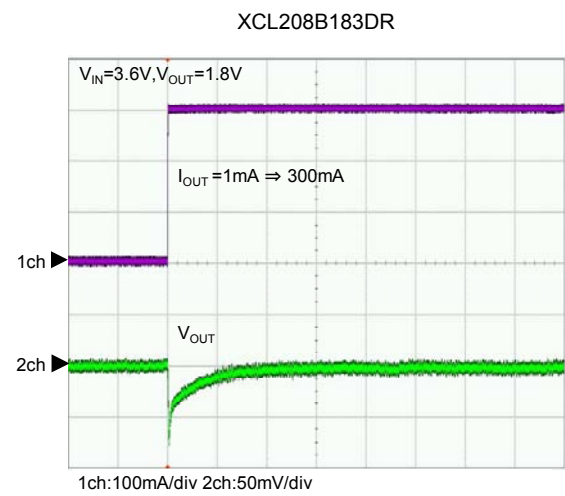

Time:100 μ s/div

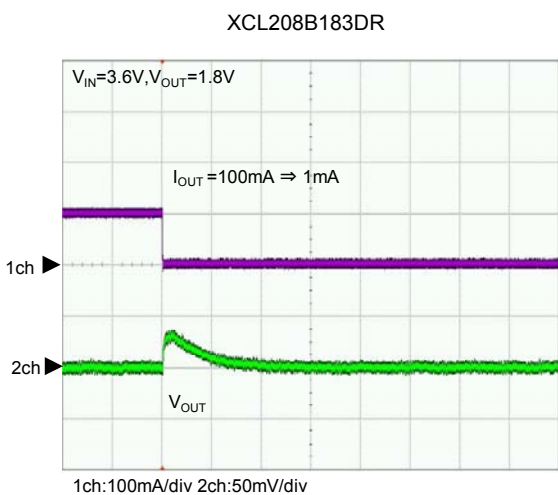

Time:100 μ s/div

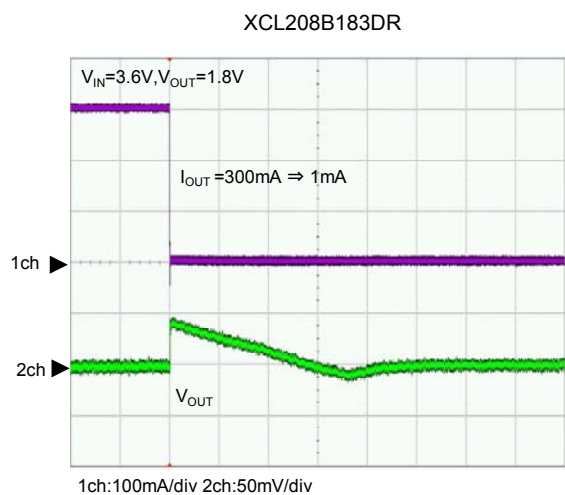

Time:100 μ s/div

PACKAGING INFORMATION

● USP-10B03 (unit: mm)

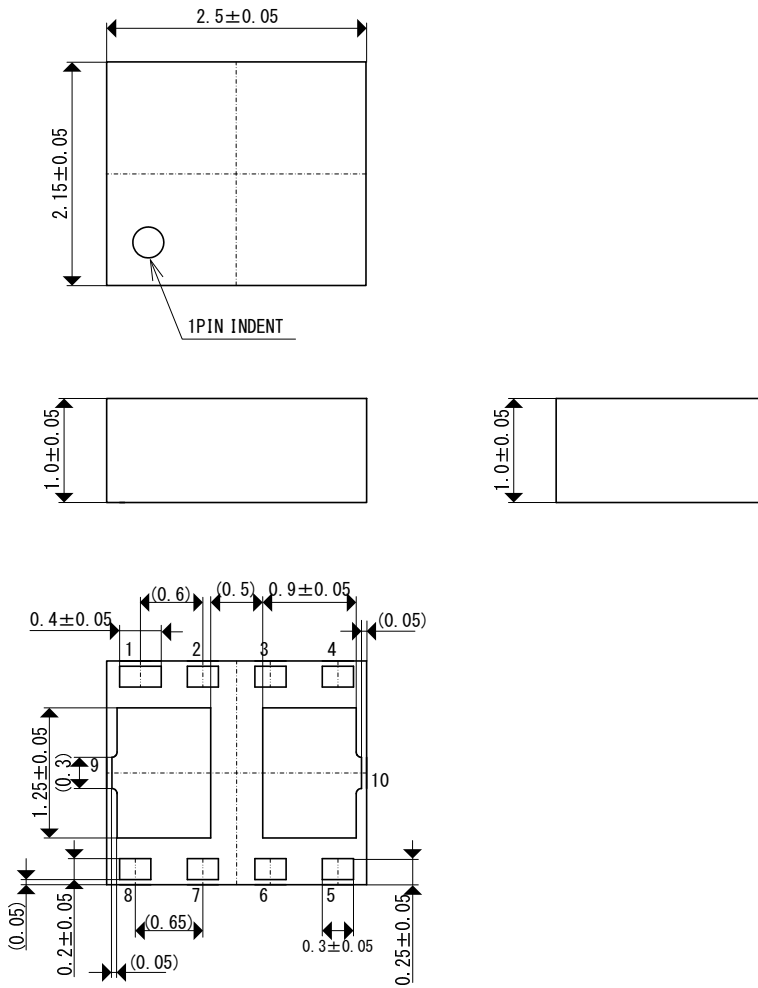

● USP-10B03 Reference Pattern Layout (unit: mm)

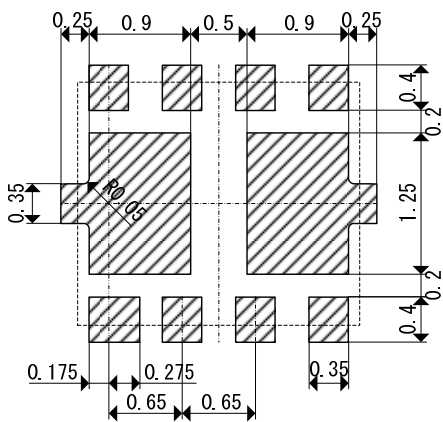

● USP-10B03 Reference Metal Mask Design (unit: mm)

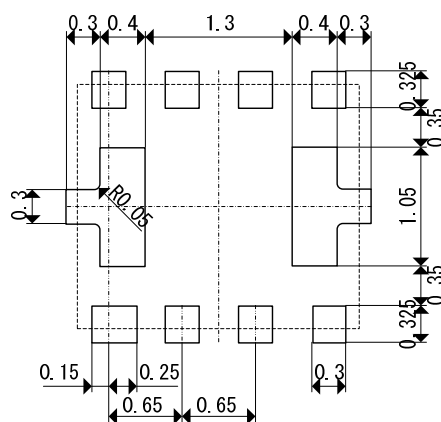

MARKING RULE

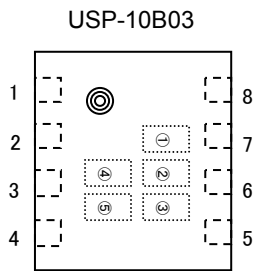

① represents products series

| MARK | PRODUCT SERIES |
|------|----------------|
| 8 | XCL208***** |
| 9 | XCL209***** |

② represents integer of output voltage and oscillation frequency

XCL20*F***** (FB Product)

| OUTPUT VOLTAGE(V) | MARK |
|-------------------|--|
| | OSCILLATION FREQUENCY=3.0MHz (XCL20*F**3**) |
| 0.x | F |

XCL20*A*****

| OUTPUT VOLTAGE (V) | MARK |
|--------------------|--|
| | OSCILLATION FREQUENCY=3.0MHz (XCL20*A**3**) |
| 0.x | 0 |
| 1.x | 1 |
| 2.x | 2 |
| 3.x | 3 |
| 4.x | 4 |

XCL20*B*****

| OUTPUT VOLTAGE (V) | MARK |
|--------------------|--|
| | OSCILLATION FREQUENCY=3.0MHz (XCL20*B**3**) |
| 0.x | A |
| 1.x | B |
| 2.x | C |
| 3.x | D |
| 4.x | E |

③ represents the decimal part of output voltage

| OUTPUT VOLTAGE (V) | MARK | PRODUCT SERIES | OUTPUT VOLTAGE (V) | MARK | PRODUCT SERIES |
|--------------------|------|----------------|--------------------|------|----------------|
| X.0 | 0 | XCL20***0*** | X.05 | A | XCL20***A*** |
| X.1 | 1 | XCL20***1*** | X.15 | B | XCL20***B*** |
| X.2 | 2 | XCL20***2*** | X.25 | C | XCL20***C*** |
| X.3 | 3 | XCL20***3*** | X.35 | D | XCL20***D*** |
| X.4 | 4 | XCL20***4*** | X.45 | E | XCL20***E*** |
| X.5 | 5 | XCL20***5*** | X.55 | F | XCL20***F*** |
| X.6 | 6 | XCL20***6*** | X.65 | H | XCL20***H*** |
| X.7 | 7 | XCL20***7*** | X.75 | K | XCL20***K*** |
| X.8 | 8 | XCL20***8*** | X.85 | L | XCL20***L*** |
| X.9 | 9 | XCL20***9*** | X.95 | M | XCL20***M*** |

Example (Mark ②, ③)

| OSCILLATION FREQUENCY | MARK | | | | | |
|-----------------------|--------------|---|--------------|---|--------------|---|
| | XCL20*F08*** | | XCL20*A18*** | | XCL20*B3D*** | |
| | ② | ③ | ② | ③ | ② | ③ |
| 3.0MHz | F | 8 | 1 | 8 | D | D |

④,⑤ represents production lot number

01~09, 0A~0Z, 11~9Z, A1~A9, AA~AZ, B1~ZZ in order.

(G, I, J, O, Q, W excluded)

*No character inversion used.

1. The product and product specifications contained herein are subject to change without notice to improve performance characteristics. Consult us, or our representatives before use, to confirm that the information in this datasheet is up to date.
2. The information in this datasheet is intended to illustrate the operation and characteristics of our products. We neither make warranties or representations with respect to the accuracy or completeness of the information contained in this datasheet nor grant any license to any intellectual property rights of ours or any third party concerning with the information in this datasheet.
3. Applicable export control laws and regulations should be complied and the procedures required by such laws and regulations should also be followed, when the product or any information contained in this datasheet is exported.
4. The product is neither intended nor warranted for use in equipment of systems which require extremely high levels of quality and/or reliability and/or a malfunction or failure which may cause loss of human life, bodily injury, serious property damage including but not limited to devices or equipment used in 1) nuclear facilities, 2) aerospace industry, 3) medical facilities, 4) automobile industry and other transportation industry and 5) safety devices and safety equipment to control combustions and explosions. Do not use the product for the above use unless agreed by us in writing in advance.
5. Although we make continuous efforts to improve the quality and reliability of our products; nevertheless Semiconductors are likely to fail with a certain probability. So in order to prevent personal injury and/or property damage resulting from such failure, customers are required to incorporate adequate safety measures in their designs, such as system fail safes, redundancy and fire prevention features.
6. Our products are not designed to be Radiation-resistant.
7. Please use the product listed in this datasheet within the specified ranges.
8. We assume no responsibility for damage or loss due to abnormal use.
9. All rights reserved. No part of this datasheet may be copied or reproduced unless agreed by Torex Semiconductor Ltd in writing in advance.

TOREX SEMICONDUCTOR LTD.

Mouser Electronics

Authorized Distributor

Click to View Pricing, Inventory, Delivery & Lifecycle Information:

Torex Semiconductor:

[XCL209B333DR](#) [XCL208B123DR](#) [XCL208B283DR](#) [XCL208B103DR](#) [XCL209B183DR](#) [XCL209A203DR](#)
[XCL209A123DR](#) [XCL208B153DR](#) [XCL209A093DR](#) [XCL209B323DR](#) [XCL209A113DR](#) [XCL209A283DR](#)
[XCL208B303DR](#) [XCL209A153DR](#) [XCL209F083DR](#) [XCL209A1D3DR](#) [XCL209B153DR](#) [XCL208F083DR](#)
[XCL209A303DR](#) [XCL209B103DR](#) [XCL209A253DR](#) [XCL209A333DR](#) [XCL209A363DR](#) [XCL208B253DR](#)
[XCL208B183DR](#) [XCL209A103DR](#) [XCL209B283DR](#)