

H25 Incremental Optical Encoder



The H25 is the flagship of the BEI Sensors product line. It was designed from the ground up for the industrial marketplace. The H25 offers features such as EMI shielding, 40 lb. ABEC 7 bearings, matched thermal coefficients on critical components, and custom high-efficiency optics. The encoder meets NEMA 4 and 13 requirements when ordered with the shaft seal. Typical applications include machine control, process control, the wood processing industry, oil well logging, industrial weighing, agricultural machinery, textile equipment, web process control, robotics, and food processing.

Special Models of the H25 Incremental Encoder are available with one or more of the following certifications. Consult factory for details.

-  EN 55011 and EN 61000-6-2
-  U.S. Standards Class I, Group A,B,C & D; Class II Group E,F & G
-  Canadian Standards Class I, Zone 0, Group IIC
-  IEC 12.0035X
-  IECEx 12.0082X
-  CENELEC II 1 G Ex ia IIB/IIC T4
-  II 3 G Ex nA IIB T4 Gc
-  Class I, Div 2, Group A,B,C & D; Class II, Div 2, Group F & G

Mechanical Specifications

Shaft Diameter: 3/8" (1/2" as special feature)
Flat On Shaft: 3/8" Shaft: 0.80 long X 0.03" deep; 1/2" Shaft: 0.80 long X 0.04" deep (1/2" shaft w/flat must be ordered as special feature)
Shaft Loading: 3/8" shaft: Up to 40 pounds axial and 35 pounds radial; 1/2" shaft: Up to 90 pounds axial and 80 pounds radial
Shaft Runout: 0.0005 T.I.R. at midpoint regardless of shaft diameter
Starting Torque at 25°C: Without shaft seal 1.0 in-oz (max); With shaft seal 2.5 in-oz (max); 1/2" shaft with shaft seal: 3.5 in-oz (max)
Bearings: Class ABEC 7 standard, ABEC 5 for 1/2" shaft
Shaft Material: 416 stainless steel
Bearing Housing: Die cast aluminum with protective finish; stainless steel (special feature)
Cover: Die cast aluminum; stainless steel (special feature)
Bearing Life: 2 X 10⁶ revs (1300 hrs at 2500 RPM) at rated load 1 X 10⁶ revs (67,000 hrs at 2500 RPM) at 10% of rated load

Maximum RPM: 12,000 RPM nominal, 8000 RPM with 1/2" shaft (see Frequency Response, below) 30,000 RPM available on units with 3/8" shaft—consult with factory
Moment of Inertia: 4.1 X 10⁻⁴ oz-in-sec²; 5.2 X 10⁻⁴ oz-in-sec² with 1/2" shaft
Weight: 13 oz typical, 14.5 oz typical with 1/2" shaft

Electrical Specifications

Code: Incremental
Output Format: 2 channels in quadrature, 1/2 cycle index gated with negative B channel
Cycles Per Shaft Turn: 1 to 72,000 (see table 2) For resolutions above 3,600 see BEI for interpolation options
Supply Voltage: 5 to 28 VDC available
Current Requirements: 100 mA typical + output load, 250 mA (max)
Voltage/Output: (see note 5)
 15V/V: Line Driver, 5–15 VDC in, V_{out} = V_{in}
 28V/V: Line Driver, 5–28 VDC in, V_{out} = V_{in}
 28V/5: Line Driver, 5–28 VDC in, V_{out} = 5 VDC
 28V/OC: Open Collector, 5–28 VDC in, OC_{out}

Protection Level: Reverse, overvoltage and output short circuit (see note 5)
Frequency Response: 100 kHz, up to 1MHz with interpolation option (see note 7)
Output Terminations: (See table 1, back)
Note: Consult factory for other electrical options

Environmental Specifications

Enclosure Rating: NEMA 4 & 13 (IP 66) when ordered with shaft seal (on units with an MS connector) or a cable gland (on units with cable termination).
Temperature: Operating, 0° to 70° C; extended temperature testing up to 105°C available; Storage, -25° to 90° C unless extended temperature option called out.
Shock: 50 g's for 11 msec duration
Vibration: 5 to 2000 Hz @ 20 g's
Humidity: 98% RH without condensation

NOTES & TABLES: All notes and tables referred to in the text can be found on the back of this page.

H25 Incremental Ordering Options for assistance call 800-350-2727

Use this diagram, working from left to right to construct your model number (example: H25D-SS-2000-ABZC-28V/V-SM18).

All notes and tables referred to can be found on pages the back of this page.

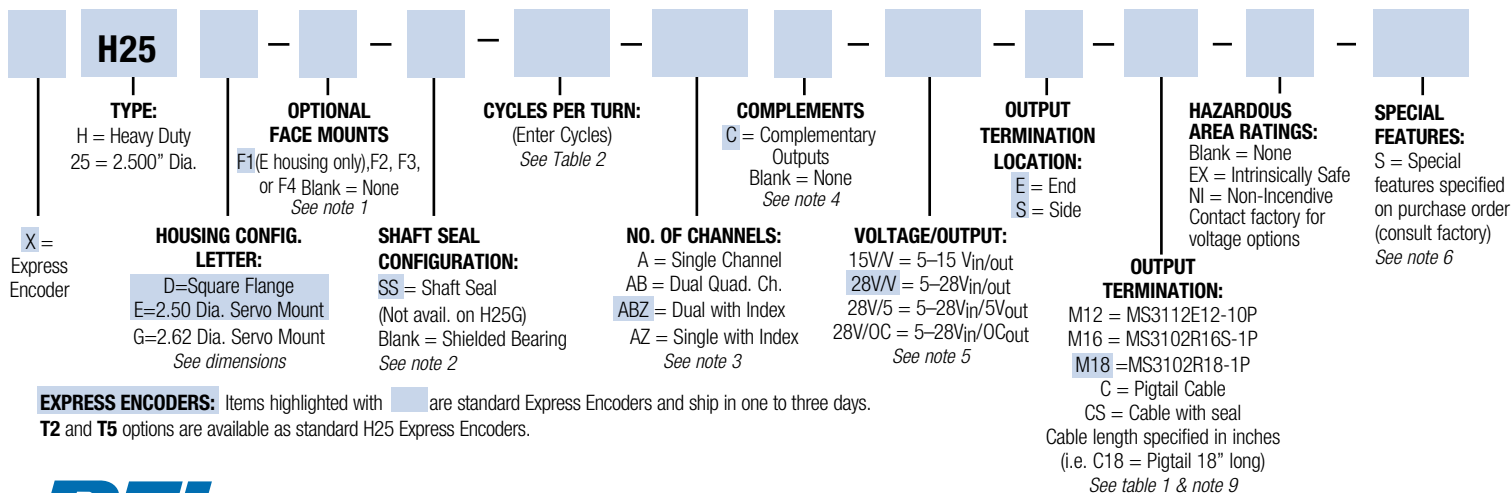

EXPRESS ENCODERS: Items highlighted with are standard Express Encoders and ship in one to three days. T2 and T5 options are available as standard H25 Express Encoders.



Tel: 805-968-0782 / 800-350-2727 | Fax: 805-968-3154 / 800-960-2726
 7230 Hollister Ave., Goleta, CA 93117-2807 | www.beisensors.com

Specification No. 02002-001 Rev.08-13

Dimensions

H25D - Square Flange

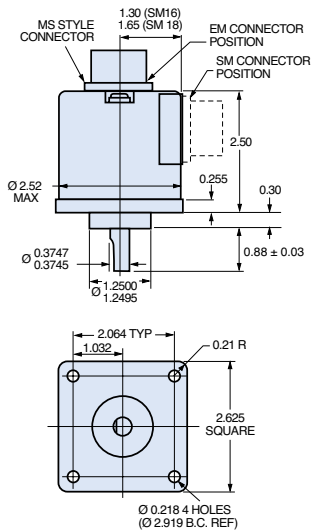

TOLERANCES: .XX = ± 0.01, .XXX = ± 0.005

H25E - 2.50 Servo Mount

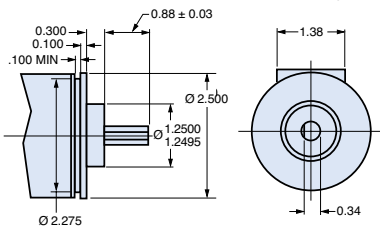

H25G - 2.62 Dia Servo Mount

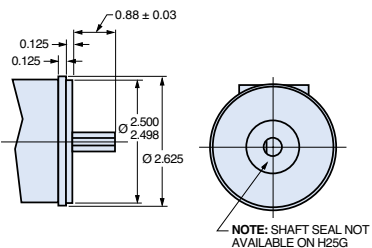

Optional Face Mounts

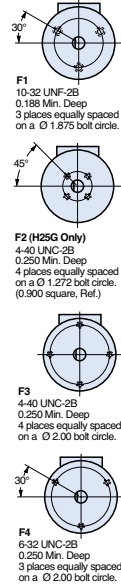
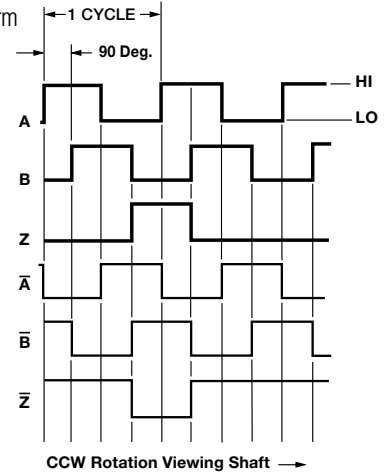

Figure 1

Output Waveform



Notes

- Mounting is usually done either using the D-style square flange mount, E- or G-style servo mounts, or one of the standard face mounts, F1 for example. Consult factory for additional face mount options.
 - The shaft seal is recommended in virtually all installations. The most common exceptions are applications requiring a very low starting torque or those requiring operation at both high temperature and high speed.
 - Non-standard index widths and multiple indices are available by special order. Consult factory.
 - Complementary outputs are recommended for use with line driver type (source/sink) outputs. When used with differential receivers, this combination provides a high degree of noise immunity.
 - Output IC's:** Output IC's are available as either Line Driver (LD) or NPN Open Collector (OC) types. Open Collectors require pull-up resistors, resulting in higher output source impedance (sink impedance is similar to that of line drivers). In general, use of a Line Driver style output is recommended. Line Drivers source or sink current and their lower impedance mean better noise immunity and faster switching times. **Warning:** Do not connect any line driver outputs directly to circuit common/OV, which may damage the driver. Unused outputs should be isolated and left floating. Our applications specialists would be pleased to discuss your system requirements and the compatibility of your receiving electronics with Line Driver type outputs.
 - 28V/V:** Multi-voltage Line Driver (7272*): 100 mA source/sink. Input voltage 5 to 28 VDC +/- 5% standard (Note: $V_{out} = V_{in}$). This driver is TTL compatible when used with 5 volt supply. Supply lines are protected against overvoltage to 60 volts and reverse voltage. Outputs are short circuit protected for one minute. Supply current is 120 mA typical (plus load current). This is the recommended replacement for 3904R and 7406R open collector outputs with internal pullup resistors. It is also a direct replacement for any 4469, 88C30, 8830 or 26LS31 line driver
 - 28V/5:** Multi-voltage Line Driver (7272*): 100 mA source/sink. Input voltage 5 to 28 VDC +/- 5% standard, internally regulated with 5V (TTL compatible) logic out. Supply lines are protected against overvoltage to 60 volts and reverse voltage. Outputs are short circuit protected for one minute. Supply current is 90 mA typical (plus load current).
 - 15V/V:** Multi-voltage Line Driver (4469*): 100 mA source/sink. Input voltage 5 to 15 VDC +/- 5% standard (Note: $V_{out} = V_{in}$). TTL compatible when used with 5 volt supply. Supply lines are protected against overvoltage to 60 volts and reverse voltage. Outputs are short circuit protected for one minute. Supply current is 90 mA typical (plus load current). This is a direct replacement for the 4469 Line Driver.
 - 28V/OC:** NPN Open Collector (3904*, 7273*): Current sink of 80 mA max. Current sourced by external pull-up resistor. Output can be pulled up to voltage other than supply voltage (30 V max). Input voltage 5 to 28 VDC +/- 5% standard. Supply current is 120 mA typical. This replaces prior IC's with designations of 3904, 7406, 3302, 681 and 689.
 - 5V/OCR, 15V/OCR, 24V/OCR:** Open Collector (3904R*, 7406R*, 7273R*): Current sink of 70 mA max. Includes internal pull-ups sized at approximately 100 ohms/volt. 5V/V, 5V/OC, 5V/OCR and 9V/OC can be intrinsically safe line driver and open collector outputs available on certain model variations. They are intrinsically safe only when installed per the control drawing noted on the certification label affixed to the encoder body.
 - 3904, 3904R, 4469, 5V/V, 5V/OC, 5V/OCR, 9V/OC:** Intrinsically safe line driver and open collector outputs. These drivers are specific to intrinsically safe encoders, and are installed per the appropriate control drawings listed in Table 2.1 on page 48.
 - Special -S at the end of the model number is used to define a variety of non-standard features such as special shaft lengths, voltage options, or special testing. Please consult the factory to discuss your special requirements.
 - Higher frequency response may be available. Please consult with the factory.
 - Mating straight plug receptacles may be ordered from the factory:
For M12 use MS3116F12-10S, For M14 use MS3106F14S-6S
For M14/19 use MS3116J14-19S, For M16 use MS3106F16S-1S
For M18 use MS3106F18-1S, For M20 use MS3106F20-29S
- * Products manufactured prior to April 2007 used the line driver IC number instead of voltage output in model number.

Tables

Table 1: Incremental Output Terminations

The connector style will determine pinouts. For example, an encoder with ABC channels and an M18 connector uses the table to the right.

M14 CONNECTOR	M16 CONNECTOR	CHANNELS DESIGNATED IN MODEL NO.	
PIN	PIN	ABZ	ABC
E	A	A	A
D	B	B	B
C	C	Z	A
B	D	+V (SUPPLY VOLTAGE)	
F	E	—	B
A	F	0 V (CIRCUIT COMMON)	
	G	CASE GROUND (CG) (except H20)	

M18 CONNECTOR	
PIN	CHANNEL
A	A
B	B
C	Z
D	+V
E	—
F	0V
G	CG
H	A
I	B
J	Z

WIRE COLOR (22AWG)	DA 15P CONNECTOR	CHANNELS DESIGNATED IN MODEL NO.		
		ABZ	ABC	ABZC
YEL	13	A	A	A
BLUE	14	B	B	B
ORN	15	Z	—	Z
W-Yel	10	—	A	A
W-Blu	11	—	B	B
W-Orn	12	—	—	Z
RED	6	+V (SUPPLY VOLTAGE)		
BLK	1	0 V (CIRCUIT COMMON)		
GRN	9	CASE GROUND (CG) (except H20)		
WHITE		SHIELD DRAIN (Shielded Cable Only)		

M12 CONNECTOR	
PIN	CHANNEL
A	A
B	B
C	Z
D	+V
E	—
F	0V
G	CG
H	A
J	B
K	Z

Table 2: Disc Resolutions for Incremental Encoder Models H25, H38, H40, L25, E25

Resolutions highlighted with are available as standard **Model H25 EXPRESS ENCODERS**® that ship in one to three days.

1, 2, 3, 5, 6, 7, 8, 10, 13, 16, 20, 24, 25, 26, 30, 32, 33, 34, 36, 37, 40, 45, 48, 50, 51, 56*, 60, 64, 66, 72, 75, 80, 86, 88, 90, 100, 102, 120, 122, 125, 127, 128, 132, 144, 148, 150, 158, 160, 175, 176, 180, 187, 192, 200, 202, 204*, 217, 220, 240, 250, 254, 255, 256, 264*, 274, 280, 283, 292, 300, 312, 320, 321, 325, 360, 366, 372, 375, 377, 380, 381, 384, 385, 393, 400, 430, 432, 450, 462, 480, 490, 500, 502, 508, 512, 522, 530, 550, 560*, 576, 598, 600, 604, 625, 635, 638, 640, 660, 672, 676, 680, 687, 690, 700, 720, 725, 735, 740, 744, 748, 750, 762, 768, 780, 785, 800, 812, 825, 850, 864, 878, 888, 900, 912, 914, 938, 942, 955, 960, 1000, 1016, 1024, 1030, 1035, 1036, 1040, 1054, 1056, 1074, 1076, 1080, 1088, 1100, 1101, 1125, 1136, 1200, 1237, 1250, 1257, 1270, 1280, 1300, 1314, 1332, 1333, 1390, 1400, 1414, 1427, 1440, 1484, 1500, 1562, 1570, 1596, 1600, 1650, 1666, 1718, 1745, 1774, 1800, 1840*, 1850, 1855, 1875, 1894, 1920, 1952, 1968, 1979, 1995, 2000, 2048, 2080, 2094, 2100, 2160, 2164, 2199, 2200, 2250, 2356, 2400, 2485, 2500, 2514, 2519, 2540, 2821, 2827, 2833, 3000, 3125, 3600, 4000, 4096, 5000

*AB or ABC output only. NOTE: Resolutions up to 72,000 are available.

These commodities, technology or software if exported from the United States must be in accordance with the Bureau of Industry, and Security, Export Administration regulations. Diversion contrary to U.S. Law is prohibited.

Mouser Electronics

Authorized Distributor

Click to View Pricing, Inventory, Delivery & Lifecycle Information:

BEI Sensors:

[H25G-F3-SB-1000-ABZ-28V/V-SM16](#) [H25G-F3-SB-1000-ABZ-28V/V-EM16](#) [H25E-F45-SS-100-ABC-28v/v-EM16](#)