

LM2765

Switched Capacitor Voltage Converter

General Description

The LM2765 CMOS charge-pump voltage converter operates as a voltage doubler for an input voltage in the range of +1.8V to +5.5V. Two low cost capacitors and a diode are used in this circuit to provide up to 20 mA of output current. The LM2765 operates at 50 kHz switching frequency to reduce output resistance and voltage ripple. With an operating current of only 130 μ A (operating efficiency greater than 90% with most loads) and 0.1 μ A typical shutdown current, the LM2765 provides ideal performance for battery powered systems. The device is manufactured in a SOT-23-6 package.

Features

- Doubles Input Supply Voltage
- SOT23-6 Package
- 20 Ω Typical Output Impedance
- 90% Typical Conversion Efficiency at 20 mA
- 0.1 μ A Typical Shutdown Current

Applications

- Cellular Phones
- Pagers
- PDAs
- Operational Amplifier Power Supplies
- Interface Power Supplies
- Handheld Instruments

Basic Application Circuits

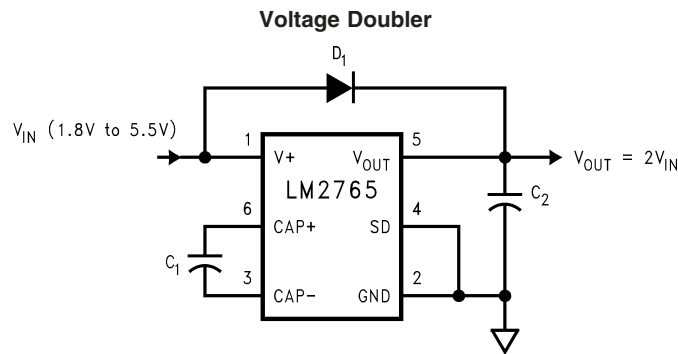

10128101

Connection Diagram

6-Lead SOT (M6)

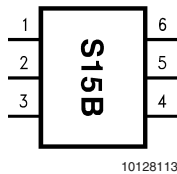

10128113
Top View With Package Marking



10128122
Actual Size

Ordering Information

Order Number	Package Number	Package Marking	Supplied as
LM2765M6	MA06A	S15B (Note 1)	Tape and Reel (1000 units/reel)
LM2765M6X	MA06A	S15B (Note 1)	Tape and Reel (3000 units/reel)

Note 1: The small physical size of the SOT-23 package does not allow for the full part number marking. Devices will be marked with the designation shown in the column Package Marking.

Pin Description

Pin	Name	Function
1	V+	Power supply positive voltage input.
2	GND	Power supply ground input.
3	CAP-	Connect this pin to the negative terminal of the charge-pump capacitor.
4	SD	Shutdown control pin, tie this pin to ground in normal operation.
5	V _{OUT}	Positive voltage output.
6	CAP+	Connect this pin to the positive terminal of the charge-pump capacitor.

Absolute Maximum Ratings (Note 2)

If Military/Aerospace specified devices are required, please contact the National Semiconductor Sales Office/Distributors for availability and specifications.

Supply Voltage (V_+ to GND, or V_+ to V_{OUT})	5.8V
SD	(GND – 0.3V) to (V_+ + 0.3V)
V_{OUT} Continuous Output Current	40 mA
Output Short-Circuit Duration to GND (Note 3)	1 sec.
Continuous Power	600 mW
Dissipation ($T_A = 25^\circ\text{C}$)(Note 4)	
$T_{J\text{Max}}$ (Note 4)	150°C

Operating Ratings

θ_{JA} (Note 4)	210°C/W
Junction Temperature Range	–40° to 100°C
Ambient Temperature Range	–40° to 85°C
Storage Temperature Range	–65°C to 150°C
Lead Temp. (Soldering, 10 seconds)	240°C
ESD Rating (Note 5)	
Human body model	2kV
Machine model	200V

Electrical Characteristics

Limits in standard typeface are for $T_J = 25^\circ\text{C}$, and limits in **boldface** type apply over the full operating temperature range. Unless otherwise specified: $V_+ = 5\text{V}$, $C_1 = C_2 = 3.3\ \mu\text{F}$. (Note 6)

Symbol	Parameter	Condition	Min	Typ	Max	Units
V_+	Supply Voltage		1.8		5.5	V
I_Q	Supply Current	No Load		130	450	μA
I_{SD}	Shutdown Supply Current			0.1	0.5	μA
		$T_A = 85^\circ\text{C}$		0.2		
V_{SD}	Shutdown Pin Input Voltage	Shutdown Mode	2.0			V
		Normal Operation			0.6	
I_L	Output Current	$2.5\text{V} \leq V_{IN} \leq 5.5\text{V}$	20			mA
		$1.8\text{V} \leq V_{IN} < 2.5\text{V}$	10			
R_{OUT}	Output Resistance (Note 7)	$I_L = 20\ \text{mA}$		20	40	Ω
f_{OSC}	Oscillator Frequency	(Note 8)	40	100	200	kHz
f_{SW}	Switching Frequency	(Note 8)	20	50	100	kHz
P_{EFF}	Power Efficiency	$I_L = 20\ \text{mA}$ to GND		92		%
V_{OEFF}	Voltage Conversion Efficiency	No Load		99.96		%

Note 2: Absolute maximum ratings indicate limits beyond which damage to the device may occur. Electrical specifications do not apply when operating the device beyond its rated operating conditions.

Note 3: V_{OUT} may be shorted to GND for one second without damage. However, shorting V_{OUT} to V_+ may damage the device and should be avoided. Also, for temperatures above 85°C , V_{OUT} must not be shorted to GND or V_+ , or device may be damaged.

Note 4: The maximum allowable power dissipation is calculated by using $P_{D\text{Max}} = (T_{J\text{Max}} - T_A)/\theta_{JA}$, where $T_{J\text{Max}}$ is the maximum junction temperature, T_A is the ambient temperature, and θ_{JA} is the junction-to-ambient thermal resistance of the specified package.

Note 5: The human body model is a 100pF capacitor discharged through a 1.5k Ω resistor into each pin. The machine model is a 200pF capacitor discharged directly into each pin.

Note 6: In the test circuit, capacitors C_1 and C_2 are 3.3 μF , 0.3 Ω maximum ESR capacitors. Capacitors with higher ESR will increase output resistance, reduce output voltage and efficiency.

Note 7: Specified output resistance includes internal switch resistance and capacitor ESR. See the details in the application information for positive voltage doubler.

Note 8: The output switches operate at one half of the oscillator frequency, $f_{OSC} = 2f_{SW}$.

Test Circuit

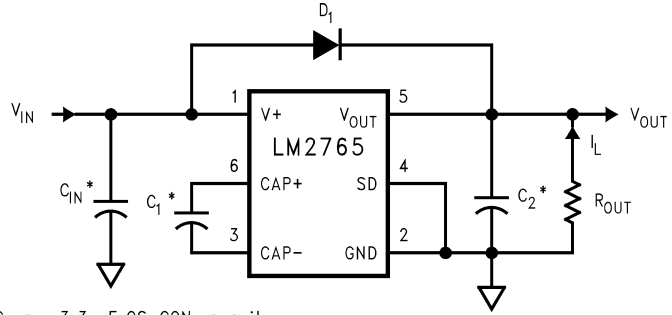

* C_{IN} , C_1 , and C_2 are $3.3 \mu\text{F}$ OS-CON capacitors.

10128103

FIGURE 1. LM2765 Test Circuit

Typical Performance Characteristics (Circuit of Figure 1, $V_{IN} = 5\text{V}$, $T_A = 25^\circ\text{C}$ unless otherwise specified)

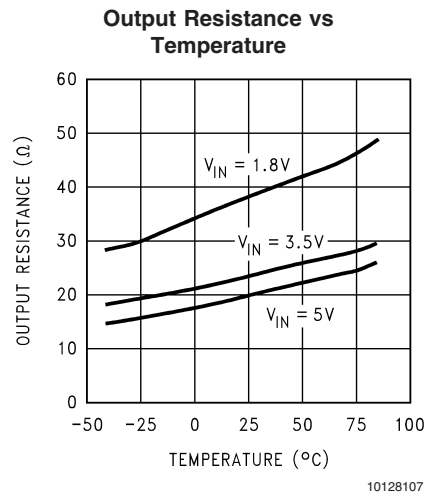
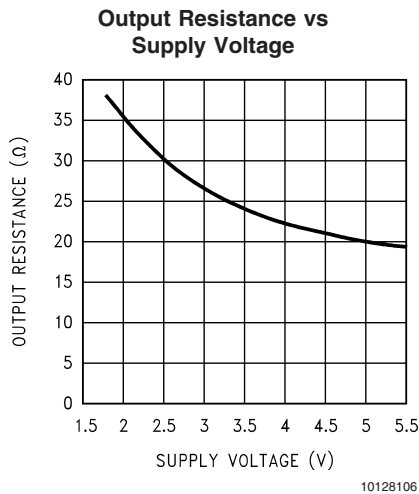
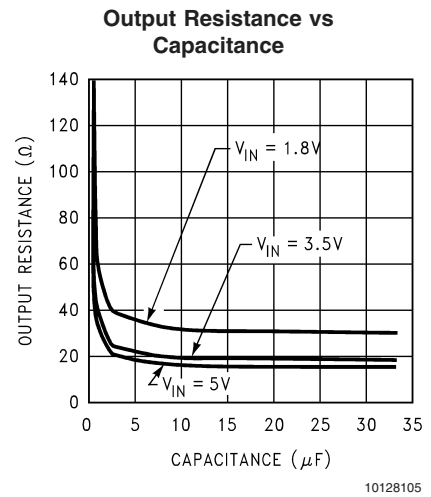
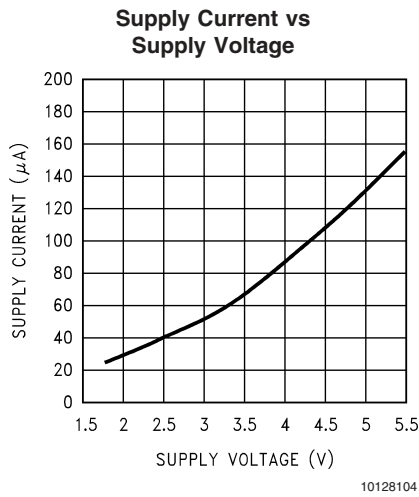

Typical Performance Characteristics (Circuit of Figure 1, $V_{IN} = 5V$, $T_A = 25^\circ C$ unless otherwise specified) (Continued)

Output Voltage vs Load Current

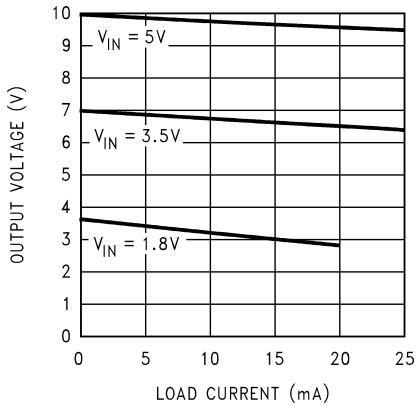

10128108

Efficiency vs Load Current

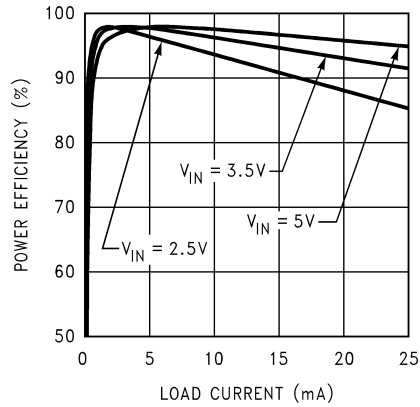

10128109

Switching Frequency vs Supply Voltage

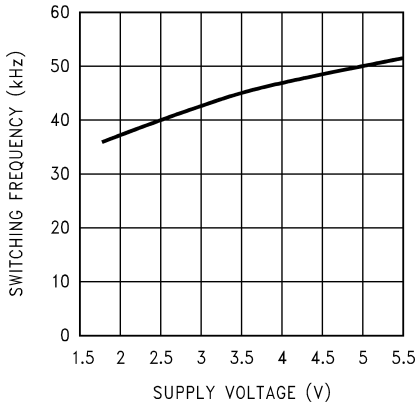

10128110

Switching Frequency vs Temperature

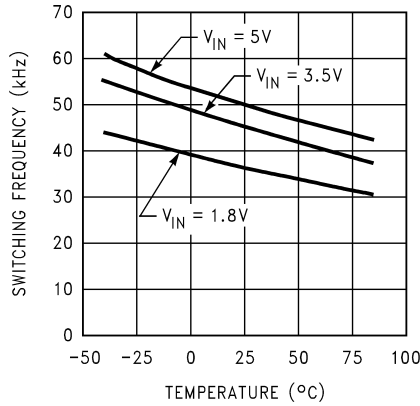

10128111

Output Ripple vs Load Current

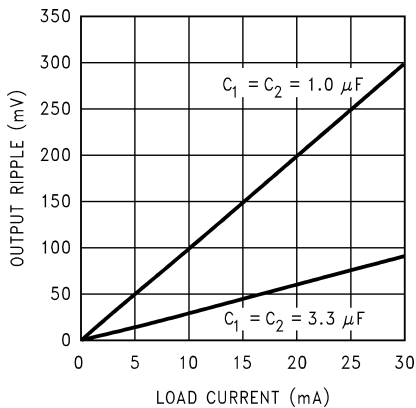

10128112

Circuit Description

The LM2765 contains four large CMOS switches which are switched in a sequence to double the input supply voltage. Energy transfer and storage are provided by external capacitors. Figure 2 illustrates the voltage conversion scheme. When S_2 and S_4 are closed, C_1 charges to the supply voltage V_+ . During this time interval, switches S_1 and S_3 are open. In the next time interval, S_2 and S_4 are open; at the same time, S_1 and S_3 are closed, the sum of the input voltage V_+ and the voltage across C_1 gives the $2V_+$ output voltage when there is no load. The output voltage drop when a load is added is determined by the parasitic resistance ($R_{ds(on)}$) of the MOSFET switches and the ESR of the capacitors) and the charge transfer loss between capacitors. Details will be discussed in the following application information section.

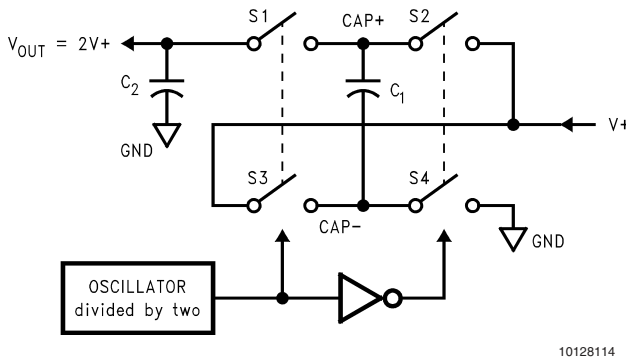

FIGURE 2. Voltage Doubling Principle

Application Information

POSITIVE VOLTAGE DOUBLER

The main application of the LM2765 is to double the input voltage. The range of the input supply voltage is 1.8V to 5.5V.

The output characteristics of this circuit can be approximated by an ideal voltage source in series with a resistance. The voltage source equals $2V_+$. The output resistance R_{out} is a function of the ON resistance of the internal MOSFET switches, the oscillator frequency, and the capacitance and ESR of C_1 and C_2 . Since the switching current charging and discharging C_1 is approximately twice as the output current, the effect of the ESR of the pumping capacitor C_1 will be multiplied by four in the output resistance. The output capacitor C_2 is charging and discharging at a current approximately equal to the output current, therefore, its ESR only counts once in the output resistance. A good approximation of R_{out} is:

$$R_{OUT} \cong 2R_{SW} + \frac{2}{f_{OSC} \times C_1} + 4ESR_{C1} + ESR_{C2}$$

where R_{SW} is the sum of the ON resistance of the internal MOSFET switches shown in Figure 2. R_{SW} is typically 8Ω for the LM2765.

The peak-to-peak output voltage ripple is determined by the oscillator frequency as well as the capacitance and ESR of the output capacitor C_2 :

$$V_{RIPPLE} = \frac{I_L}{f_{OSC} \times C_2} + 2 \times I_L \times ESR_{C2}$$

High capacitance, low ESR capacitors can reduce both the output resistance and the voltage ripple.

The Schottky diode D_1 is only needed to protect the device from turning-on its own parasitic diode and potentially latching-up. During start-up, D_1 will also quickly charge up the output capacitor to V_{IN} minus the diode drop thereby decreasing the start-up time. Therefore, the Schottky diode D_1 should have enough current carrying capability to charge the output capacitor at start-up, as well as a low forward voltage to prevent the internal parasitic diode from turning-on. A Schottky diode like 1N5817 can be used for most applications. If the input voltage ramp is less than 10V/ms, a smaller Schottky diode like MBR0520LT1 can be used to reduce the circuit size.

SHUTDOWN MODE

A shutdown (SD) pin is available to disable the device and reduce the quiescent current to 0.1 μ A. In normal operating mode, the SD pin is connected to ground. The device can be brought into the shutdown mode by applying to the SD pin a voltage greater than 40% of the V_+ pin voltage.

CAPACITOR SELECTION

As discussed in the *Positive Voltage Doubler* section, the output resistance and ripple voltage are dependent on the capacitance and ESR values of the external capacitors. The output voltage drop is the load current times the output resistance, and the power efficiency is

$$\eta = \frac{P_{OUT}}{P_{IN}} = \frac{I_L^2 R_L}{I_L^2 R_L + I_L^2 R_{OUT} + I_Q(V_+)}$$

Where $I_Q(V_+)$ is the quiescent power loss of the IC device, and $I_L^2 R_{out}$ is the conversion loss associated with the switch on-resistance, the two external capacitors and their ESRs.

The selection of capacitors is based on the specifications of the dropout voltage (which equals $I_{out} R_{out}$), the output voltage ripple, and the converter efficiency. Low ESR capacitors (Table 1) are recommended to maximize efficiency, reduce the output voltage drop and voltage ripple.

Application Information (Continued)

TABLE 1. Low ESR Capacitor Manufacturers

Manufacturer	Phone	Website	Capacitor Type
Nichicon Corp.	(847)-843-7500	www.nichicon.com	PL & PF series, through-hole aluminum electrolytic
AVX Corp.	(843)-448-9411	www.avxcorp.com	TPS series, surface-mount tantalum
Sprague	(207)-324-4140	www.vishay.com	593D, 594D, 595D series, surface-mount tantalum
Sanyo	(619)-661-6835	www.sanyovideo.com	OS-CON series, through-hole aluminum electrolytic
Murata	(800)-831-9172	www.murata.com	Ceramic chip capacitors
Taiyo Yuden	(800)-348-2496	www.t-yuden.com	Ceramic chip capacitors
Tokin	(408)-432-8020	www.tokin.com	Ceramic chip capacitors

Other Applications

PARALLELING DEVICES

Any number of LM2765s can be paralleled to reduce the output resistance. Each device must have its own pumping capacitor C_1 , while only one output capacitor C_{out} is needed as shown in Figure 3. The composite output resistance is:

$$R_{OUT} = \frac{R_{OUT} \text{ of each LM2765}}{\text{Number of Devices}}$$

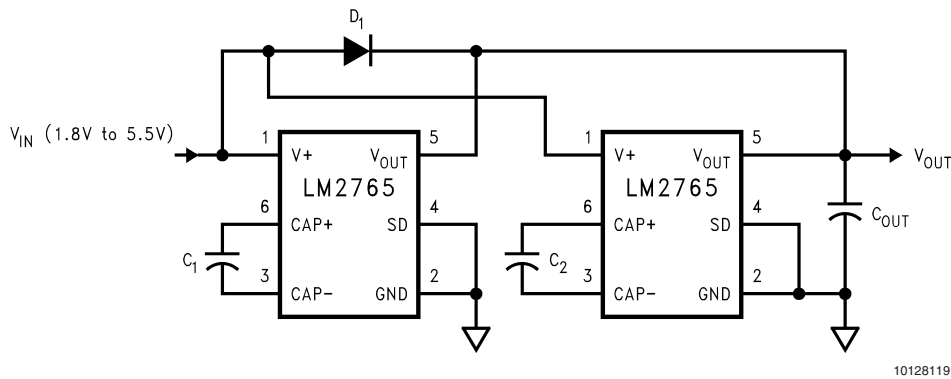

FIGURE 3. Lowering Output Resistance by Paralleling Devices

CASCADING DEVICES

Cascading the LM2765s is an easy way to produce a greater voltage (A two-stage cascade circuit is shown in Figure 4). The effective output resistance is equal to the weighted sum of each individual device:

$$R_{out} = 1.5R_{out_1} + R_{out_2}$$

Note that increasing the number of cascading stages is practically limited since it significantly reduces the efficiency, increases the output resistance and output voltage ripple.

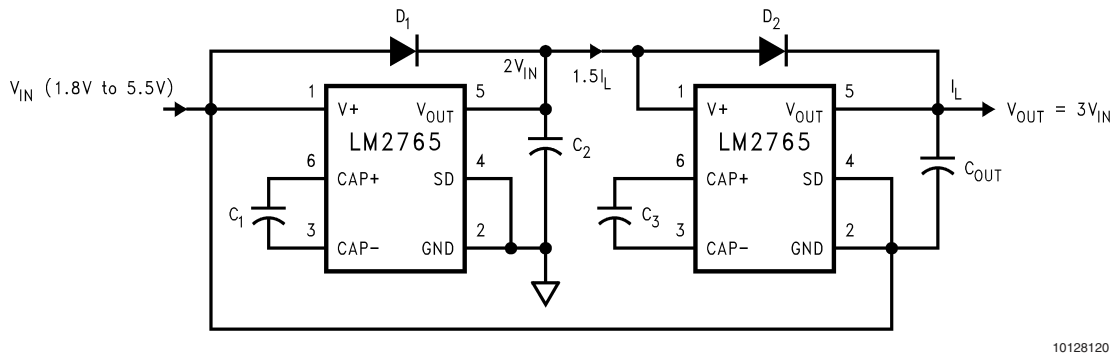

FIGURE 4. Increasing Output Voltage by Cascading Devices

Other Applications (Continued)

REGULATING V_{OUT}

It is possible to regulate the output of the LM2765 by use of a low dropout regulator (such as LP2980-5.0). The whole converter is depicted in Figure 5.

A different output voltage is possible by use of LP2980-3.3, LP2980-3.0, or LP2980-adj.

Note that the following conditions must be satisfied simultaneously for worst case design:

$$2V_{in_min} > V_{out_min} + V_{drop_max}(LP2980) + I_{out_max} \times R_{out_max}(LM2765)$$

$$2V_{in_max} < V_{out_max} + V_{drop_min}(LP2980) + I_{out_min} \times R_{out_min}(LM2765)$$

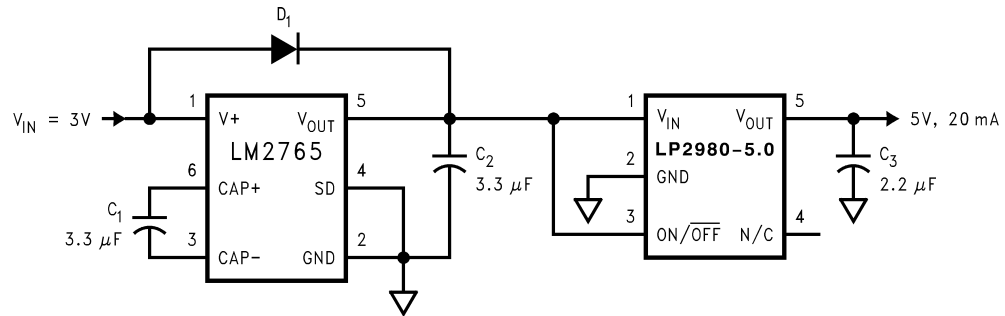

10128121

FIGURE 5. Generate a Regulated +5V from +3V Input Voltage

Physical Dimensions inches (millimeters) unless otherwise noted

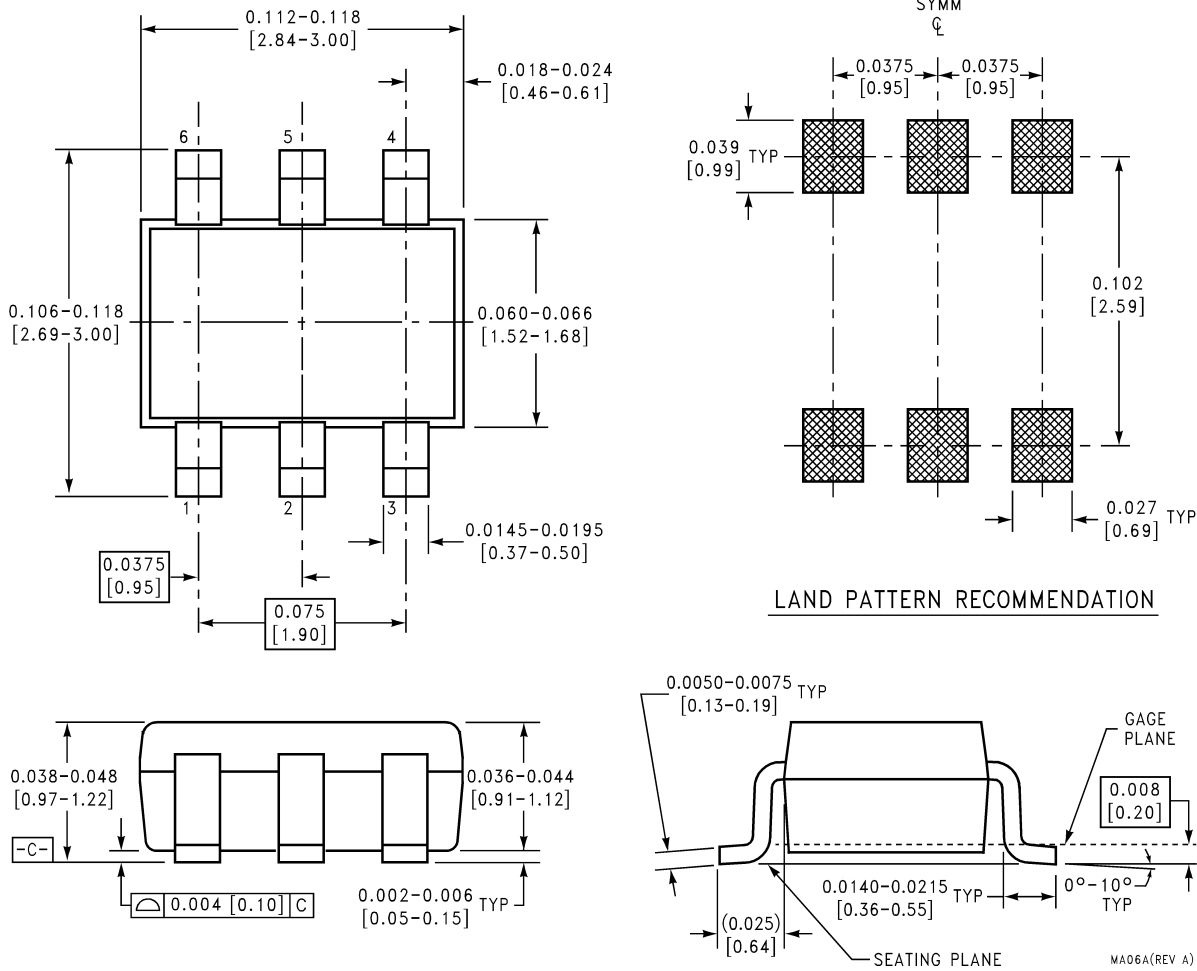

**6-Lead Small Outline Package (M6)
NS Package Number MA06A**
For Order Numbers, refer to the table in the "Ordering Information" section of this document.

National does not assume any responsibility for use of any circuitry described, no circuit patent licenses are implied and National reserves the right at any time without notice to change said circuitry and specifications.

For the most current product information visit us at www.national.com.

LIFE SUPPORT POLICY

NATIONAL'S PRODUCTS ARE NOT AUTHORIZED FOR USE AS CRITICAL COMPONENTS IN LIFE SUPPORT DEVICES OR SYSTEMS WITHOUT THE EXPRESS WRITTEN APPROVAL OF THE PRESIDENT AND GENERAL COUNSEL OF NATIONAL SEMICONDUCTOR CORPORATION. As used herein:

1. Life support devices or systems are devices or systems which, (a) are intended for surgical implant into the body, or (b) support or sustain life, and whose failure to perform when properly used in accordance with instructions for use provided in the labeling, can be reasonably expected to result in a significant injury to the user.
2. A critical component is any component of a life support device or system whose failure to perform can be reasonably expected to cause the failure of the life support device or system, or to affect its safety or effectiveness.

BANNED SUBSTANCE COMPLIANCE

National Semiconductor certifies that the products and packing materials meet the provisions of the Customer Products Stewardship Specification (CSP-9-111C2) and the Banned Substances and Materials of Interest Specification (CSP-9-111S2) and contain no "Banned Substances" as defined in CSP-9-111S2.



National Semiconductor
Americas Customer Support Center
Email: new.feedback@nsc.com
Tel: 1-800-272-9959

National Semiconductor
Europe Customer Support Center
Fax: +49 (0) 180-530 85 86
Email: europe.support@nsc.com
Deutsch Tel: +49 (0) 69 9508 6208
English Tel: +44 (0) 870 24 0 2171
Français Tel: +33 (0) 1 41 91 8790

National Semiconductor
Asia Pacific Customer Support Center
Email: ap.support@nsc.com

National Semiconductor
Japan Customer Support Center
Fax: 81-3-5639-7507
Email: jpn.feedback@nsc.com
Tel: 81-3-5639-7560

www.national.com