



Photocouplers

LTV-0701

Data Sheet

Created Date : 01/ 02/ 2012
Revision : 1.0, 01/ 02/ 2012



Lite-on Technology Corp.
Optoelectronics SBG
<http://www.liteon.com/opto>



Photocouplers LTV-0701

1. DESCRIPTION

These high gain series couplers use a light emitter diode and an integrated high gain photo detector to provide extremely high current transfer ratio between input and output. Separate pins for the photodiode and output stage result in TTL compatible saturation voltage and high speed operation. Where desired the V_{cc} and V_o terminals may be tied together to achieve conventional photo darlington operation. A base access terminal allows a gain bandwidth adjustment to be made.

1.1 Features

- SO8 package
- High current transfer ratio – 2000% typical.
- Low input current requirements – 0.5mA
- High output current – 60mA
- CTR guarantee – 0~70°C.
- Instantaneous common mode rejection 10KV/ μ sec
- TTL compatible output – 0.1V V_{OL} typical

1.2 Applications

- Digital logic ground isolation
- Low input current line receiver
- Telephone ring detector
- EIA-RS-232C line receiver
- Current loop receiver
- High common mode noise line receiver

1.3 Functional Diagram

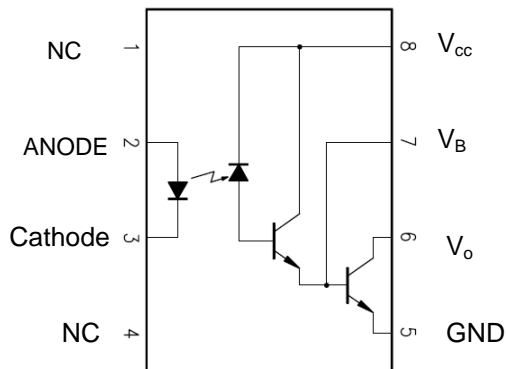

Truth Table (Positive Logic)

LED	OUT
ON	L
OFF	H

A 0.1 μ F bypass Capacitor must be connected between Pin8 and Pin5

Photocouplers
LTV-0701

2. PACKAGE DIMENSIONS

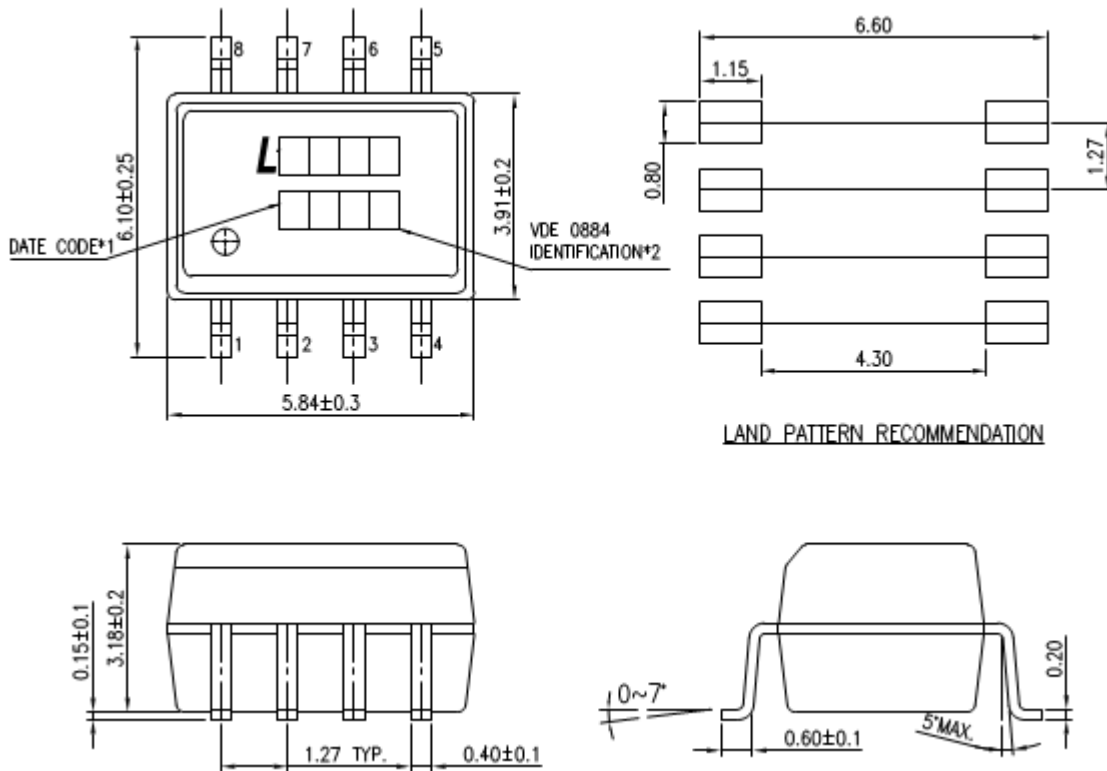

Part No : LTV-0701

Notes :

1. Date code
2. "V" to represent VDE0884
3. Date code
4. Dimensions are all in Millimeters.

Photocouplers LTV-0701

3. TAPING DIMENSIONS

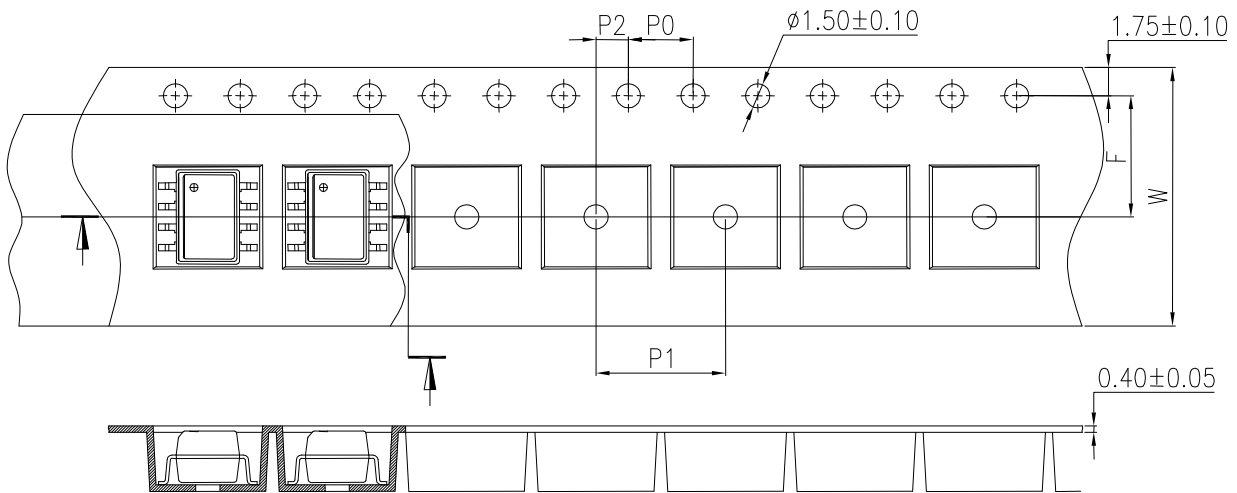

Description	Symbol	Dimension in mm (inch)
Tape wide	W	16±0.3 (0.63)
Pitch of sprocket holes	P ₀	4±0.1 (0.15)
Distance of compartment	F	7.5±0.1 (0.295)
	P ₂	2±0.1 (0.079)
Distance of compartment to compartment	P ₁	8±0.1 (0.47)

Quantities Per Reel

Package Type	LTV-0701
Quantities (pcs)	2000

Photocouplers LTV-0701

4. RATING AND CHARACTERISTICS

4.1 Absolute Maximum Ratings at Ta=25°C *1

	Parameter	Symbol	Rating	Unit
Input	Average Forward Input Current	I_F	20	mA
	Reverse Input Voltage	V_R	5	V
	Power Dissipation	P_I	35	mW
Output	Output Collector Current	I_O	60	mA
	Output Collector Voltage	V_O	-0.5~18	V
	Output Collector Power Dissipation	P_o	100	mW
	Isolation Voltage	V_{iso}	3750	V_{rms}
	Supply Voltage	V_{CC}	-0.5~7	V
	Operating Temperature	T_{opr}	-55 ~ +85	°C
	Storage Temperature	T_{stg}	-55 ~ +125	°C
	Lead Solder Temperature *2	T_{sol}	260	°C

1. Ambient temperature = 25°C, unless otherwise specified. Stresses exceeding the absolute maximum ratings can cause permanent damage to the device. Exposure to absolute maximum ratings for long periods of time can adversely affect reliability.
2. 260°C for 10 seconds. Refer to Lead Free Reflow Profile.

Photocouplers LTV-0701

4.2 ELECTRICAL OPTICAL CHARACTERISTICS at Ta=25°C

Parameter	Symbol	Min.	Typ.	Max.	Unit	Test Condition
Input						
Input Forward Voltage	V_F	—	—	1.8	V	$I_F=16\text{mA}$, $T_A=25^\circ\text{C}$
Input Forward Voltage Temperature Coefficient	$\Delta V_F/\Delta T_A$	—	-1.8	—	mV/°C	$I_F=1.6\text{mA}$
Input Reverse Voltage	BV_R	5.0	—	—	V	$I_R = 10\mu\text{A}$
Input Capacitance	C_{IN}	—	60	—	pF	$V_F=0$; $f=1\text{MHz}$
Detector						
Current transfer ratio	CTR	400	1800	5000	%	$I_F=0.5\text{mA}$; $V_{CC}=4.5\text{V}$; $T_A=25^\circ\text{C}$; $V_o=0.4\text{V}$
		500	2000	2600		$I_F=1.6\text{mA}$; $V_{CC}=4.5\text{V}$; $T_A=25^\circ\text{C}$; $V_o=0.5\text{V}$
Logic low output voltage output voltage	V_{OL}	—	0.06	0.1	V	$I_F=0.5\text{mA}$; $V_{CC}=4.5\text{V}$; $I_o=2\text{mA}$
		—	0.1	0.4		$I_F=1.6\text{mA}$; $V_{CC}=4.5\text{V}$; $I_o=8\text{mA}$
		—	0.2	0.4		$I_F=5\text{mA}$; $V_{CC}=4.5\text{V}$; $I_o=15\text{mA}$
		—	0.2	0.4		$I_F=12\text{mA}$; $V_{CC}=4.5\text{V}$; $I_o=24\text{mA}$
Logic high output current	I_{OH}	—	0.3	100	μA	$I_F=0\text{mA}$, $V_o=V_{CC}=18\text{V}$ $T_A=25^\circ\text{C}$
Logic low supply current	I_{ccL}	—	0.7	1.5	mA	$I_F=1.6\text{mA}$, $V_o=\text{open}$ ($V_{CC}=18\text{V}$)
Logic high supply current	I_{ccH}	—	0.07	10	mA	$I_F=0\text{mA}$, $V_o=\text{open}$, $T_A=25^\circ\text{C}$ ($V_{CC}=18\text{V}$)

*All Typical at $T_A=25^\circ\text{C}$

Photocouplers LTV-0701

5. SWITCHING SPECIFICATION

$T_A=0\sim 70^{\circ}\text{C}$, $V_{CC}=5\text{V}$, unless otherwise specified.

Parameter	Symbol	Min.	Typ.	Max.	Unit	Test Condition
Propagation Delay Time to Low Output Level	t_{PHL}	—	—	25	μs	$I_F=0.5\text{mA}$; $R_L=4.7\text{K}\Omega$
		—	—	3		$I_F=12\text{mA}$; $R_L=270\Omega$
Propagation Delay Time to High Output Level	t_{PLH}	—	—	60	μs	$I_F=0.5\text{mA}$; $R_L=4.7\text{K}\Omega$
		—	—	20		$I_F=12\text{mA}$; $R_L=270\Omega$
Logic High Common Mode Transient Immunity	$ CM_H $	1	10	—	$\text{KV}/\mu\text{s}$	$I_F=0\text{mA}$; $ V_{CM} =10\text{V}_{p-p}$ $R_L=2.2\text{K}\Omega$
Logic Low Common Mode Transient Immunity	$ CM_L $	1	10	—	$\text{KV}/\mu\text{s}$	$I_F=1.6\text{mA}$; $ V_{CM} =10\text{V}_{p-p}$ $R_L=2.2\text{K}\Omega$

*All Typical at $T_A=25^{\circ}\text{C}$

Photocouplers LTV-0701

6. ISOLATION CHARACTERISTIC

Parameter	Symbol	Min.	Typ.	Max.	Unit	Test Condition
Input-Output Insulation Leakage Current	I_{I-O}	—	—	1.0	μA	45% RH, $t = 5\text{s}$, $V_{I-O} = 3\text{kV DC}$, $T_A = 25^\circ\text{C}$
Withstand Insulation Test Voltage	V_{ISO}	3750	—	—	V_{RMS}	RH $\leq 50\%$, $t = 1\text{min}$, $T_A = 25^\circ\text{C}$
Input-Output Resistance	R_{I-O}	—	10^{12}	—	Ω	$V_{I-O} = 500\text{V DC}$

*All Typical at $T_A = 25^\circ\text{C}$

Notes

- AC For 1 Minute, R.H. = 40 ~ 60%. Isolation voltage shall be measured using the following method.
 - Short between anode and cathode on the primary side and between collector and emitter on the secondary side.
 - The isolation voltage tester with zero-cross circuit shall be used.
 - The waveform of applied voltage shall be a sine wave.
- For 10 Seconds
- Current Transfer Ratio (CTR) is defined as the ration of output collector current, I_o , to the forward LED input current, I_F , times 100%.
- Pin 7 open.
- Instantaneous common mode rejection voltage "output (1)" represents a common mode voltage variation that can hold the output above (1) level ($V_o > 2.0\text{V}$). Instantaneous common mode rejection voltage "output (0)" represents a common mode voltage variation that can hold the output above (0) level ($V_o < 0.8\text{V}$).
- Device considered a two terminal device. Pins 1, 2, 3 and 4 shorted together and Pins 5, 6, 7 and 8 shorted together.

Photocouplers LTV-0701

7. CHARACTERISTICS CURVES

Figure 1: DC and pulsed transfer characteristics

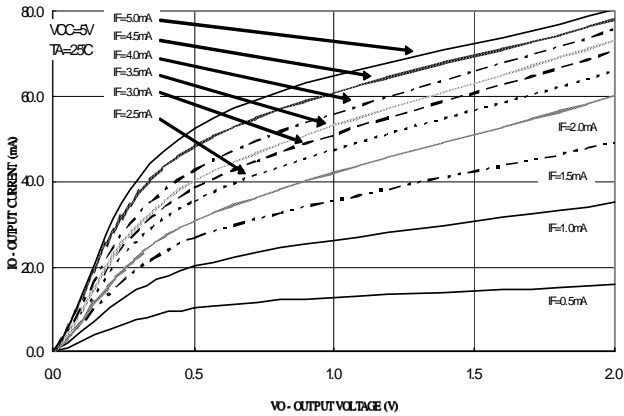

Figure 2: Input current vs. forward voltage

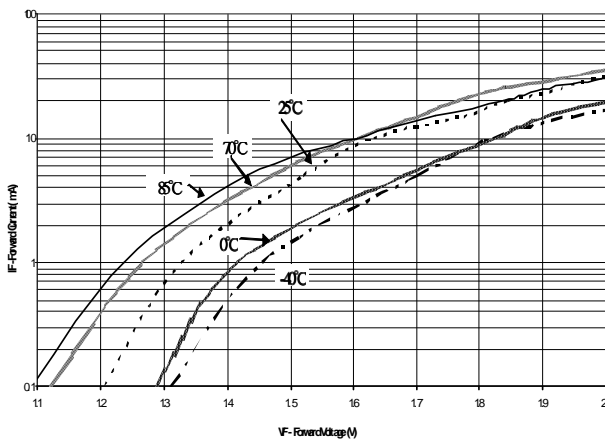

Figure 3: Logic high output current vs. temperature

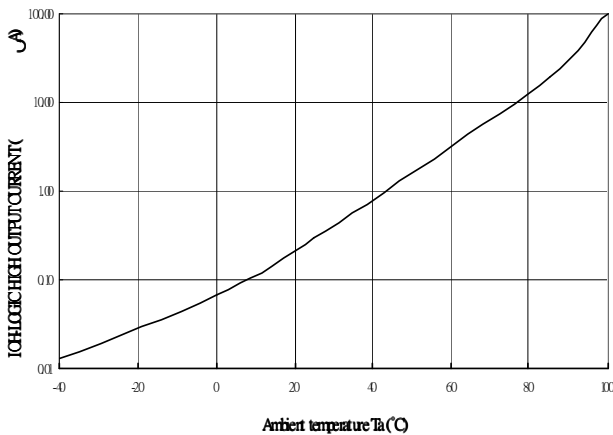

Figure 4: Current transfer ratio vs. input current

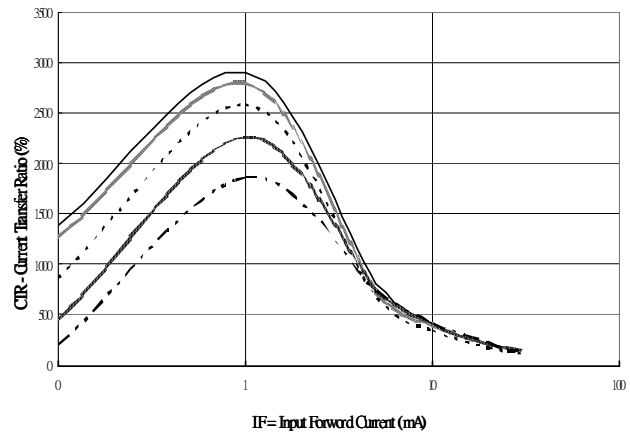

Figure 5: Current transfer ratio vs. temperature

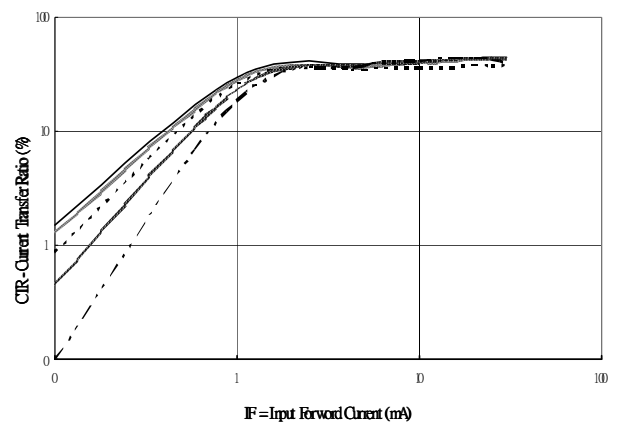
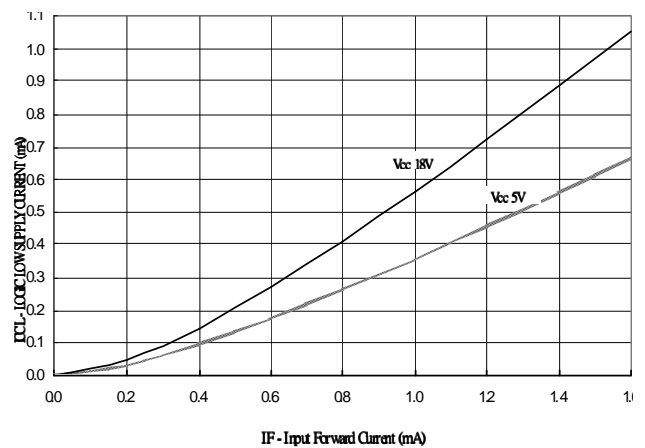

Figure 6: Logic low supply current vs. input forward current



Photocouplers LTV-0701

Figure 7: Propagation delay time vs. temperature

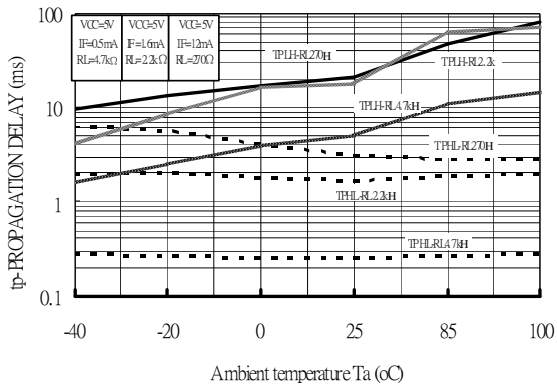
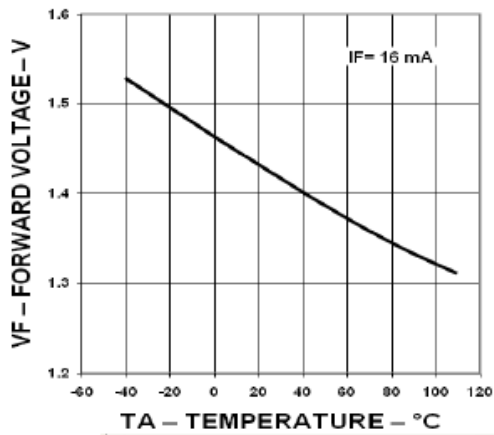

Figure 8: Forward voltage vs. temperature



8. Switching Time Test Circuit

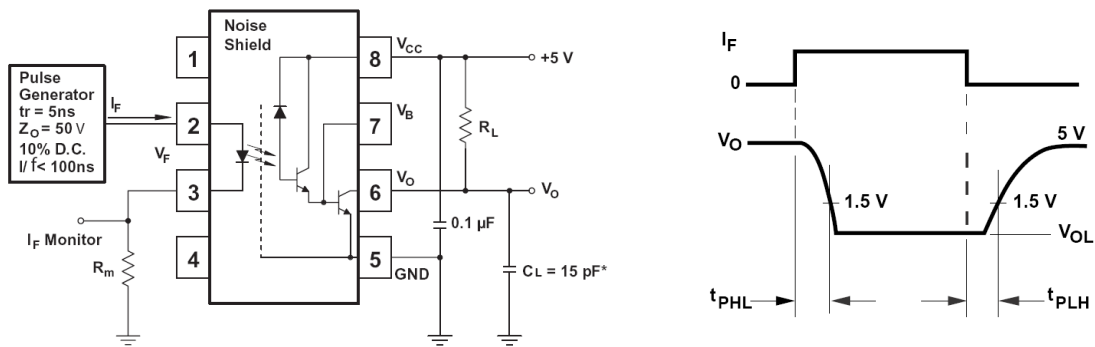

Figure 1: Single Channel Test Circuit for t_{PHL} and t_{PLH}

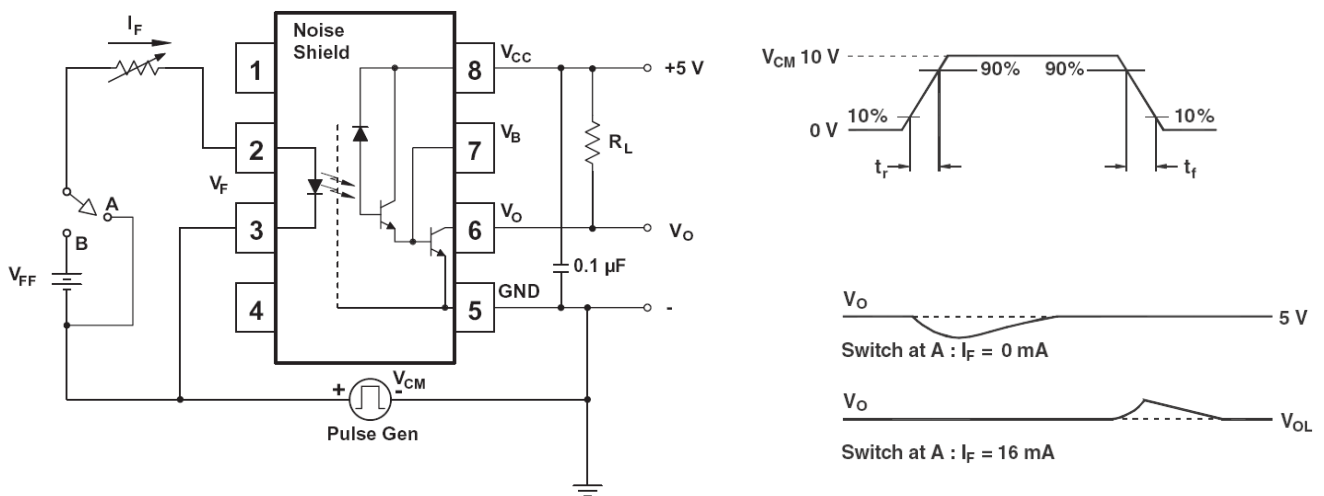

Figure 2: Single Channel Test Circuit for Common Mode Transient Immunity

9. TEMPERATURE PROFILE OF SOLDERING

9.1 IR Reflow soldering (JEDEC-STD-020C compliant)

One time soldering reflow is recommended within the condition of temperature and time profile shown below. Do not solder more than three times.

Profile item	Conditions
Preheat	
- Temperature Min (T_{Smin})	150°C
- Temperature Max (T_{Smax})	200°C
- Time (min to max) (ts)	90±30 sec
Soldering zone	
- Temperature (T_L)	217°C
- Time (t_L)	60 sec
Peak Temperature (T_P)	260°C
Ramp-up rate	3°C / sec max.
Ramp-down rate	3~6°C / sec

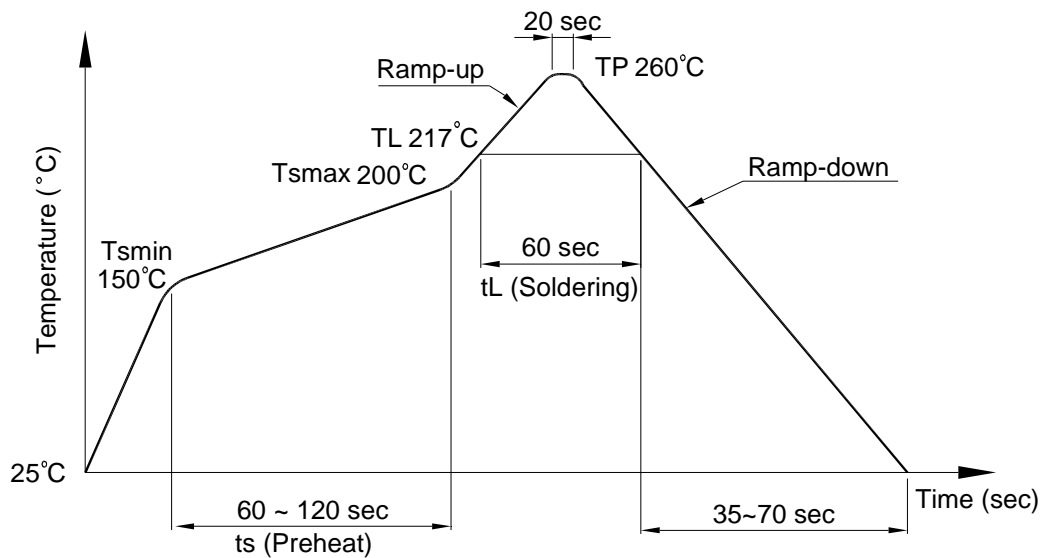

Photocouplers LTV-0701

9.2 Wave soldering (JEDEC22A111 compliant)

One time soldering is recommended within the condition of temperature.

Temperature: $260 \pm 0 / -5^{\circ}\text{C}$

Time: 10 sec.

Preheat temperature: 25 to 140°C

Preheat time: 30 to 80 sec.

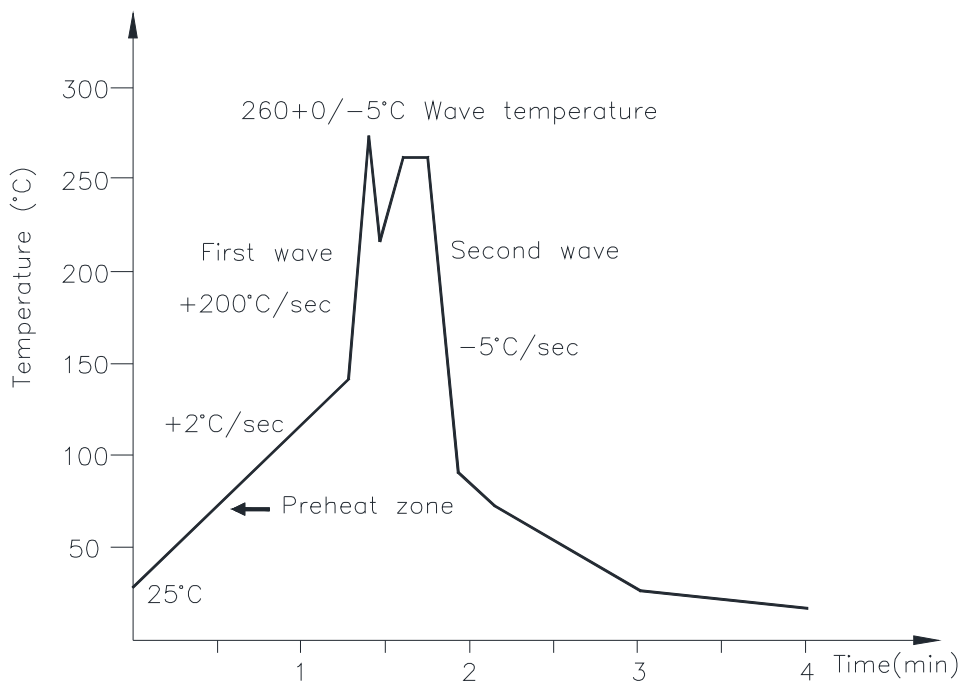

9.3 Hand soldering by soldering iron

Allow single lead soldering in every single process. One time soldering is recommended.

Temperature: $380 \pm 0 / -5^{\circ}\text{C}$

Time: 3 sec max.

10. Notes:

Specifications of the products displayed herein are subject to change without notice.

The products shown in this publication are designed for the general use in electronic applications such as office automation equipment, communications devices, audio/visual equipment, electrical instrumentation and application. For equipment/devices where high reliability or safety is required, such as space applications, nuclear power control equipment, medical equipment, etc, please contact our sales representatives.

Mouser Electronics

Authorized Distributor

Click to View Pricing, Inventory, Delivery & Lifecycle Information:

[Lite-On:](#)

[LTV-0701](#)