



## 1 Overview

### 1.1 Features

- Three Half-Bridges
- Optimized for DC motor management applications
- Delivers up to 0.6 A continuous, 1.2 A peak current
- $R_{DS\ ON}$ ; typ. 0.8  $\Omega$ , @ 25 °C per switch
- Output: short circuit protected and diagnosis
- Overtemperature-Protection with hysteresis and diagnosis
- Standard SPI-Interface/Daisy chain capable
- Very low current consumption in stand-by (Inhibit) mode (typ. 10  $\mu$ A for power and 2  $\mu$ A for logic supply, @ 25 °C)
- Over- and Undervoltage-Lockout
- CMOS/TTL compatible inputs with hysteresis
- No crossover current
- Internal clamp diodes
- Enhanced power P-DSO-Package
- Programming compatibility to the TLE 5208-6
- Green Product (RoHS compliant)
- AEC Qualified



Type	Package
TLE 6208-3 G	PG-DSO-14-35

### Functional Description

The TLE 6208-3 G is a fully protected **Triple-Half-Bridge-Driver** designed specifically for automotive and industrial motion control applications. The part is based on the Siemens power technology SPT<sup>®</sup> which allows bipolar and CMOS control circuitry in accordance with DMOS power devices existing on the same monolithic circuitry.

In motion control up to 2 actuators (DC-Motors) can be connected to the 3 halfbridge-outputs (cascade configuration). Operation modes forward (cw), reverse (ccw), brake and high impedance are controlled from a standard SPI-Interface. The possibility to control the outputs via software from a central logic, allows limiting the power dissipation. So the standard P-DSO-14-package meets the application requirements and saves PCB-Board-space and cost. Furthermore the build-in features like Over- and Undervoltage-Lockout, Over-Temperature-Protection and the very low quiescent current in stand-by mode opens a wide range of automotive- and industrial-applications.

## 1.2 Pin Configuration (top view)

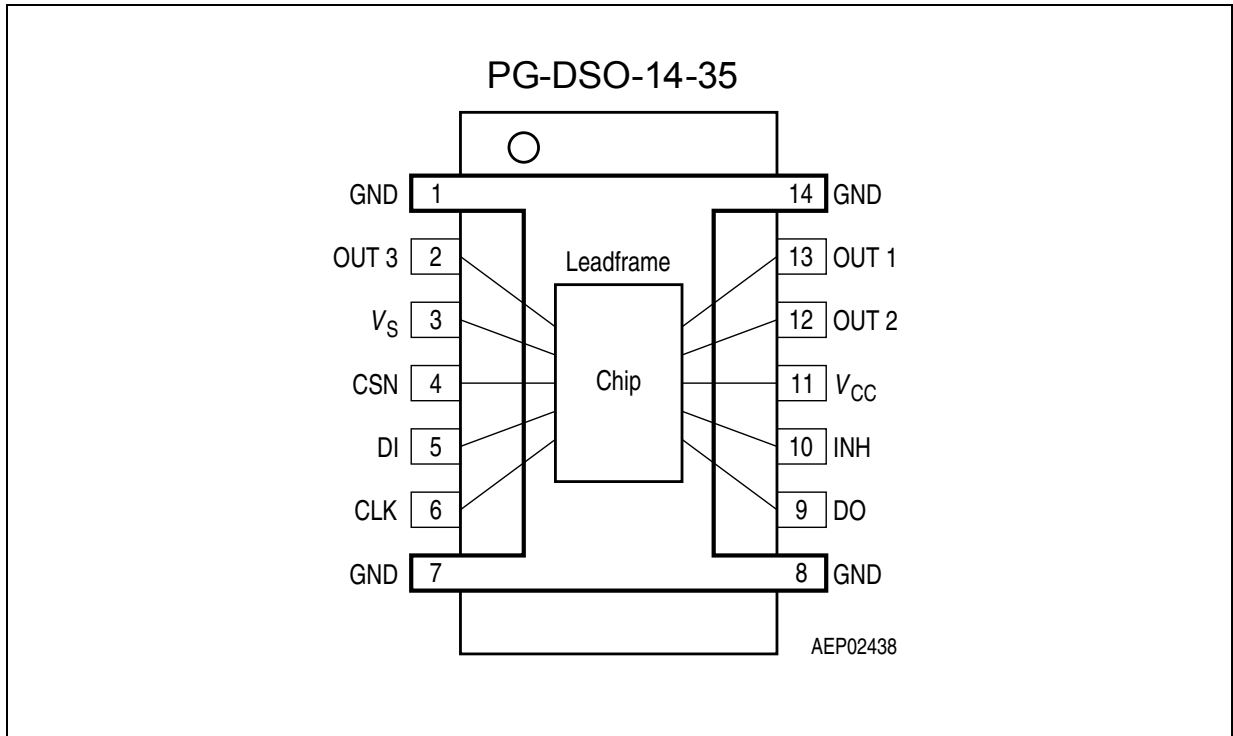

Figure 1

### 1.3 Pin Definitions and Functions

Pin No.	Symbol	Function
1	GND	<b>Ground;</b> Reference potential; internal connection to pin 7, 8 and 14; cooling tab; to reduce thermal resistance place cooling areas on PCB close to these pins.
2	OUT3	<b>Halfbridge-Output 3;</b> Internally connected to Highside-Switch 3 and Lowside-Switch 3. The HS-Switch is a Power-MOS open drain with internal reverse diode; The LS-Switch is a Power-MOS open source with internal reverse diode; no internal clamp diode or active zenering; short circuit protected and open load controlled.
3	$V_S$	<b>Power Supply;</b> needs a blocking capacitor as close as possible to GND Value: 22 $\mu$ F electrolytic in parallel to 220 nF ceramic.
5	DI	<b>Serial Data Input;</b> receives serial data from the control device; serial data transmitted to DI is an 16bit control word with the Least Significant Bit (LSB) being transferred first: the input has an active pull down and requires CMOS logic level inputs; DI will accept data on the falling edge of CLK-signal; see <b>Table Input Data Protocol</b> .
4	CSN	<b>Chip-Select-Not Input;</b> CSN is an active low input; serial communication is enabled by pulling the CSN terminal low; CSN input should only be transitioned when CLK is low; CSN has an internal active pull up and requires CMOS logic level inputs.
6	CLK	<b>Serial Clock Input;</b> clocks the shiftregister; CLK has an internal active pull down and requires CMOS logic level inputs.
7, 8, 14	GND	<b>Ground;</b> see pin 1.
9	DO	<b>Serial-Data-Output;</b> this 3-state output transfers diagnosis data to the control device; the output will remain 3-stated unless the device is selected by a low on Chip-Select-Not (CSN); see <b>Table Diagnosis Data Protocol</b> .
10	INH	<b>Inhibit Input;</b> has an internal pull down; device is switched in standby condition by pulling the INH terminal low.
11	$V_{CC}$	<b>Logic Supply Voltage;</b> needs a blocking capacitor as close as possible to GND; Value: 10 $\mu$ F electrolytic in parallel to 220 nF ceramic.
12	OUT2	<b>Halfbridge-Output 2;</b> see pin 2.
13	OUT1	<b>Halfbridge-Output 1;</b> see pin 2.

### 1.4 Functional Block Diagram

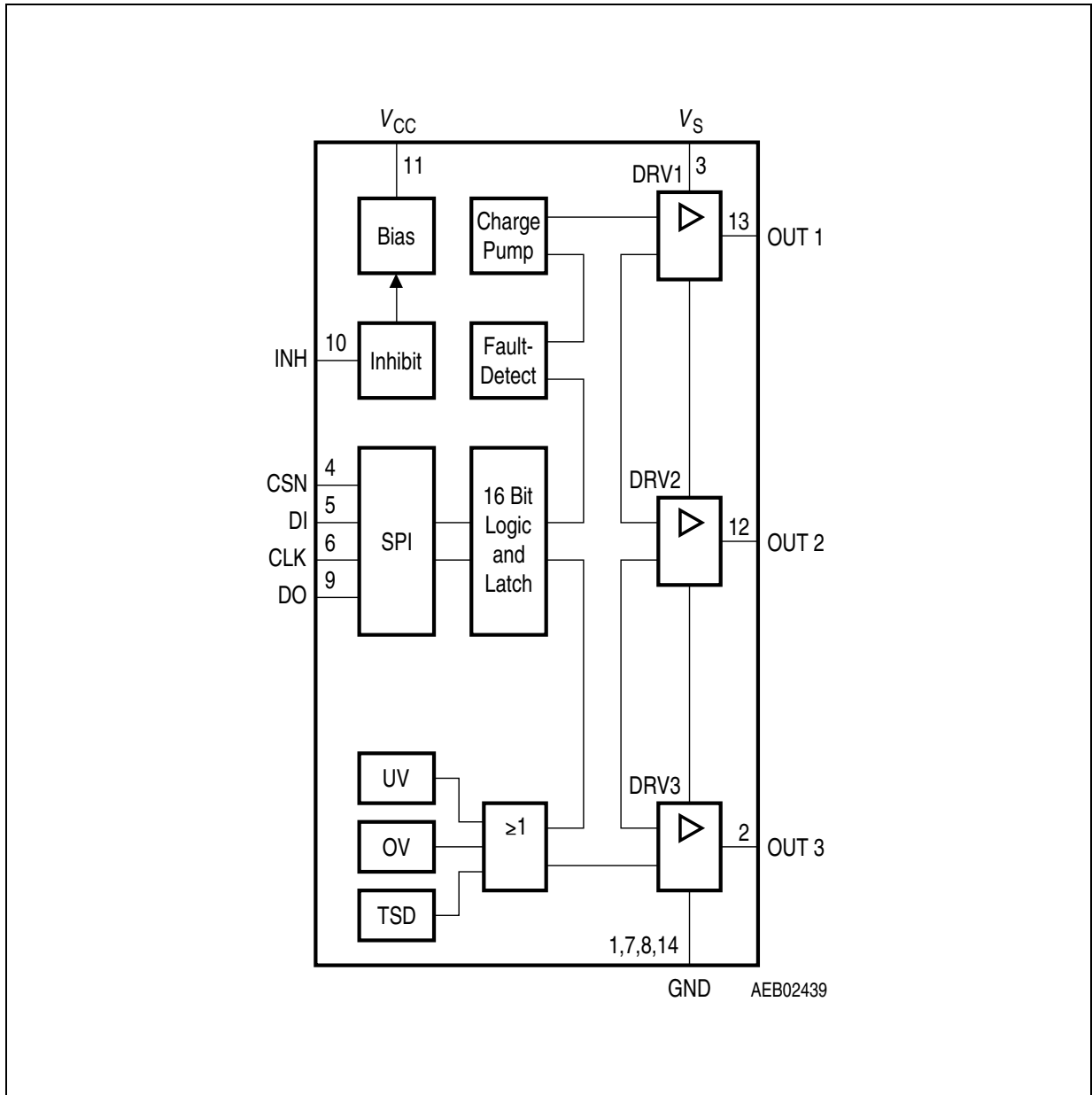

Figure 2 Block Diagram

## 1.5 Circuit Description

**Figure 2** shows a block schematic diagram of the module. There are 3 halfbridge drivers on the right-hand side. An HS driver and an LS driver are combined to form a halfbridge driver in each case. The drivers communicate via the internal data bus with the logic and the other control and monitoring functions: undervoltage (UV), overvoltage (OV), overtemperature (TSD), charge pump and fault detect.

Two connection interfaces are provided for supply to the module: All power drivers are connected to the supply voltage  $V_S$ . These are monitored by overvoltage and undervoltage comparators with hysteresis, so that the correct function can be checked in the application at any time.

The logic is supplied by the  $V_{CC}$  voltage, typ. with 5 V. The  $V_{CC}$  voltage uses an internally generated Power-On Reset (POR) to initialize the module at power-on. The advantage of this system is that information stored in the logic remains intact in the event of short-term failures in the supply voltage  $V_S$ . The system can therefore continue to operate following  $V_S$  undervoltage, without having to be reprogrammed. The “undervoltage” information is stored, and can be read out via the interface. The same logically applies for overvoltage. “Interference spikes” on  $V_S$  are therefore effectively suppressed.

The situation is different in the case of undervoltage on the  $V_{CC}$  connection pin. If this occurs, then the internally stored data is deleted, and the output levels are switched to high-impedance status (tristate). The module is initialized by  $V_{CC}$  following restart (Power-On Reset = POR).

The 16-bit wide programming word or control word (see **Table Input Data Protocol**) is read in via the DI data input, and this is synchronized with the clock input CLK. The status word appears synchronously at the DO data output (see **Table Diagnosis Data Protocol**). It is also possible to connect two **TLE 6208-3 G** in a daisy chain configuration. The DO data output of one device is connected with the DI data input of the second device. In this configuration these two devices are controlled with a single CSN chip select and using a 32-bit wide control word.

The transmission cycle begins when the chip is selected with the CSN input (H to L). If the CSN input changes from L to H then the word which has been read in becomes the control word. The DO output switches to tristate status at this point, thereby releasing the DO bus circuit for other uses.

The INH inhibit input can be used to cut off the complete module. This reduces the current consumption to just a few  $\mu\text{A}$ , and results in the loss of any data stored. The output levels are switched to tristate status. The module is reinitialized with the internally generated POR (Power-On Reset) at restart.

This feature allows the use of this module in battery-operated applications (vehicle body control applications).

Every driver block from DRV 1 to 3 contains a low-side driver and a high-side driver. Both drivers are connected internally to form a half-bridge at the output. This reduction of output pins was necessary to meet the small P-DSO-14 package.

When commutating inductive loads, the dissipated power peak can be significantly reduced by activating the transistor located parallel to the internal freewheeling diode. A special, integrated "timer" for power ON/OFF times ensures that there is no crossover current.

### Input Data Protocol

BIT	
15	OVLO on/off
14	not used
13	Overcurrent SD on/off
12	not used
11	not used
10	not used
9	not used
8	not used
7	not used
6	HS-Switch 3
5	LS-Switch 3
4	HS-Switch 2
3	LS-Switch 2
2	HS-Switch 1
1	LS-Switch 1
0	Status Register Reset

H = ON  
L = OFF

### Diagnosis Data Protocol

BIT	
15	Power supply fail
14	Underload
13	Overload
12	not used
11	not used
10	not used
9	not used
8	not used
7	not used
6	Status HS-Switch 3
5	Status LS-Switch 3
4	Status HS-Switch 2
3	Status LS-Switch 2
2	Status HS-Switch 1
1	Status LS-Switch 1
0	Temp. Prewarning

H = ON  
L = OFF

### Fault Result Table

Fault	Diag.-Bit	Result
Overcurrent (load)	13	Only the failed output is switched OFF. Function can be deactivated by bit No. 13.
Short circuit to GND (high-side-switch)	13	Only the failed output is switched OFF. Function can be deactivated by bit No. 13.

**Fault Result Table**

Fault	Diag.-Bit	Result
Short circuit to $V_S$ (low-side-switch)	13	Only the failed output is switched OFF. Function can be deactivated by bit No. 13.
Temperature warning	0	Reaction of control device needed.
Temperature shut down (SD)	–	All outputs OFF. Temperature warning is set before.
Underload/Openload	14	Reaction of control device needed.
Undervoltage lockout (UVLO)	15	All outputs OFF.
Overvoltage lockout (OVLO)	15	All outputs OFF. Function can be deactivated by bit No. 15.

H = failure;  
L = no failure.

## 2 Electrical Characteristics

### 2.1 Absolute Maximum Ratings

Parameter	Symbol	Limit Values		Unit	Remarks
		min.	max.		
Supply voltage	$V_S$	– 0.3	40	V	–
Supply voltage	$V_S$	– 1	–	V	$t < 0.5 \text{ s}; I_S > -2 \text{ A}$
Logic supply voltage	$V_{CC}$	– 0.3	5.5	V	$0 \text{ V} < V_S < 40 \text{ V}$
Logic input voltages (DI, CLK, CSN, INH)	$V_I$	– 0.3	5.5	V	$0 \text{ V} < V_S < 40 \text{ V}$ $0 \text{ V} < V_{CC} < 5.5 \text{ V}$
Logic output voltage (DO)	$V_{DO}$	– 0.3	5.5	V	$0 \text{ V} < V_S < 40 \text{ V}$ $0 \text{ V} < V_{CC} < 5.5 \text{ V}$
Output voltage (OUT 1-3)	$V_{OUT}$	– 0.3	40	V	$0 \text{ V} < V_S < 40 \text{ V}$
Output current (cont.)	$I_{OUT1-3}$	–	–	A	internal limited
Output current (peak)	$I_{OUT1-3}$	–	–	A	internal limited

*Note: Current limits are mentioned in the overcurrent section of electrical characteristics*

Junction temperature	$T_j$	– 40	150	°C	–
Storage temperature	$T_{stg}$	– 50	150	°C	–

## 2 Electrical Characteristics

### 2.1 Absolute Maximum Ratings (cont'd)

Parameter	Symbol	Limit Values		Unit	Remarks
		min.	max.		
ESD voltage, human body model, according to: <ul style="list-style-type: none"> <li>• MIL STD 883D,</li> <li>• ANSI EOS\ESD S5.1</li> <li>• JEDEC JESD22-A114</li> </ul>	$V_{\text{ESD-HBM}}$	–	–	4kV	all pins
	$V_{\text{ESD-HBM-OUT}}$	–	–	8kV	only pins 2, 12 and 13 (outputs)
ESD voltage, machine model, according to: <ul style="list-style-type: none"> <li>• ANSI EOS\ESD S5.2</li> <li>• JEDEC JESD22-A115</li> </ul>	$V_{\text{ESD-MM}}$	–	–	300V	all pins

*Note: Stresses above those listed here may cause permanent damage to the device. Exposure to absolute maximum rating conditions for extended periods may affect device reliability.*

### 2.2 Operating Range

Parameter	Symbol	Limit Values		Unit	Remarks
		min.	max.		
Supply voltage	$V_{\text{S}}$	$V_{\text{UV OFF}}$	40	V	After $V_{\text{S}}$ rising above $V_{\text{UV ON}}$
Supply voltage slew rate	$dV_{\text{S}}/dt$	–	10	V/ $\mu\text{s}$	–
Logic supply voltage	$V_{\text{CC}}$	4.75	5.50	V	–
Supply voltage increasing	$V_{\text{S}}$	– 0.3	$V_{\text{UV ON}}$	V	Outputs in tristate
Supply voltage decreasing	$V_{\text{S}}$	– 0.3	$V_{\text{UV OFF}}$	V	Outputs in tristate
Logic input voltage (DI, CLK, CSN, INH)	$V_{\text{I}}$	– 0.3	$V_{\text{CC}}$	V	–
SPI clock frequency	$f_{\text{CLK}}$	–	1	MHz	–
Junction temperature	$T_{\text{j}}$	– 40	150	°C	–

### Thermal Resistances



## 2.2 Operating Range (cont'd)

Parameter	Symbol	Limit Values		Unit	Remarks
		min.	max.		
Junction pin	$R_{thj-pin}$	–	30	K/W	measured to pin 1, 7, 8, 14
Junction ambient	$R_{thjA}$	–	65	K/W	–

*Note: In the operating range, the functions given in the circuit description are fulfilled.*

## 2.3 Electrical Characteristics

8 V <  $V_S$  < 40 V; 4.75 V <  $V_{CC}$  < 5.25 V; INH = High; all outputs open; – 40 °C <  $T_j$  < 150 °C; unless otherwise specified

Parameter	Symbol	Limit Values			Unit	Test Condition
		min.	typ.	max.		

### Current Consumption

Quiescent current	$I_S$	–	8	20	$\mu$ A	INH = Low; $V_S = 13.2$ V $T_j = 25$ °C
Quiescent current	$I_S$	–	–	30	$\mu$ A	INH = Low; $V_S = 13.2$ V;
Logic-Supply current	$I_{CC}$	–	2	10	$\mu$ A	INH = Low
Logic-Supply current	$I_{CC}$	–	1	2	mA	SPI not active
Supply current	$I_S$	–	2	5	mA	–

### Over- and Under-Voltage Lockout

UV-Switch-ON voltage	$V_{UV ON}$	–	6.5	7	V	$V_S$ increasing
UV-Switch-OFF voltage	$V_{UV OFF}$	5.6	6.1	6.6	V	$V_S$ decreasing
UV-ON/OFF-Hysteresis	$V_{UV HY}$	–	0.4	–	V	$V_{UV ON} - V_{UV OFF}$
OV-Switch-OFF voltage	$V_{OV OFF}$	34	37	40	V	$V_S$ increasing
OV-Switch-ON voltage	$V_{OV ON}$	30	33	36	V	$V_S$ decreasing
OV-ON/OFF-Hysteresis	$V_{OV HY}$	–	4	–	V	$V_{OV OFF} - V_{OV ON}$

### 2.3 Electrical Characteristics (cont'd)

8 V <  $V_S$  < 40 V; 4.75 V <  $V_{CC}$  < 5.25 V; INH = High; all outputs open;  $-40\text{ }^\circ\text{C} < T_j < 150\text{ }^\circ\text{C}$ ;  
unless otherwise specified

Parameter	Symbol	Limit Values			Unit	Test Condition
		min.	typ.	max.		

#### Outputs OUT1-3

##### Static Drain-Source-On Resistance

Source (High-Side) $I_{OUT} = -0.5\text{ A}$	$R_{DS\ ON\ H}$	-	0.8	0.95	$\Omega$	$8\text{ V} < V_S < 40\text{ V}$ $T_j = 25\text{ }^\circ\text{C}$
			-	1.6	$\Omega$	$8\text{ V} < V_S < 40\text{ V}$
			1	-	$\Omega$	$V_{S\ OFF} < V_S \leq 8\text{ V}$ $T_j = 25\text{ }^\circ\text{C}$
			-	2	$\Omega$	$V_{S\ OFF} < V_S \leq 8\text{ V}$
Sink (Low-Side) $I_{OUT} = 0.5\text{ A}$	$R_{DS\ ON\ L}$	-	0.75	0.9	$\Omega$	$8\text{ V} < V_S < 40\text{ V}$ $T_j = 25\text{ }^\circ\text{C}$
			-	1.5	$\Omega$	$8\text{ V} < V_S < 40\text{ V}$
			1	-	$\Omega$	$V_{S\ OFF} < V_S \leq 8\text{ V}$ $T_j = 25\text{ }^\circ\text{C}$
			-	2	$\Omega$	$V_{S\ OFF} < V_S \leq 8\text{ V}$

##### Leakage Current

Source-Output-Stage 1 to 3	$I_{QLH}$	-5	-1	-	$\mu\text{A}$	$V_{OUT1-3} = 0\text{ V}$
Sink-Output-Stage 1 to 3	$I_{QLL}$	-	150	300	$\mu\text{A}$	$V_{OUT1-3} = V_S$

##### Overcurrent

Source shutdown threshold	$I_{SDU}$	-2	-1.3	-1	A	-
Sink shutdown threshold	$I_{SDL}$	1	1.2	2	A	-
Current limit	$I_{OCL}$	-	2.4	4	A	sink and source
Shutdown delay time	$t_{dSD}$	10	28	40	$\mu\text{s}$	sink and source

##### Open Circuit/Underload Detection

Detection current	$I_{OCD}$	15	30	45	mA	-
-------------------	-----------	----	----	----	----	---

### 2.3 Electrical Characteristics (cont'd)

8 V <  $V_S$  < 40 V; 4.75 V <  $V_{CC}$  < 5.25 V; INH = High; all outputs open;  $-40\text{ }^\circ\text{C} < T_j < 150\text{ }^\circ\text{C}$ ;  
unless otherwise specified

Parameter	Symbol	Limit Values			Unit	Test Condition
		min.	typ.	max.		
Delay time	$t_{dOC}$	200	370	600	$\mu\text{s}$	–

**Output Delay Times;  $V_S = 13.2\text{ V}$ ;  $R_{Load} = 25\ \Omega$**  (device not in stand-by for  $t > 1\text{ ms}$ )

Source ON	$t_{d\ ON\ H}$	–	8	20	$\mu\text{s}$	–
Source OFF	$t_{d\ OFF\ H}$	–	4	20	$\mu\text{s}$	–
Sink ON	$t_{d\ ON\ L}$	–	7	20	$\mu\text{s}$	–
Sink OFF	$t_{d\ OFF\ L}$	–	3	20	$\mu\text{s}$	–
Dead time	$t_{D\ HL}$	1	3	–	$\mu\text{s}$	$t_{d\ ON\ L} - t_{d\ OFF\ H}$
Dead time	$t_{D\ LH}$	1	5	–	$\mu\text{s}$	$t_{d\ ON\ H} - t_{d\ OFF\ L}$

**Output Switching Times;  $V_S = 13.2\text{ V}$ ;  $R_{Load} = 25\ \Omega$**  (device not in stand-by for  $t > 1\text{ ms}$ )

Source ON	$t_{ON\ H}$	–	5	20	$\mu\text{s}$	–
Source OFF	$t_{OFF\ H}$	–	2	5	$\mu\text{s}$	–
Sink ON	$t_{ON\ L}$	–	2.0	10	$\mu\text{s}$	–
Sink OFF	$t_{OFF\ L}$	–	1.5	5	$\mu\text{s}$	–

#### Clamp Diodes Forward Voltage

Upper	$V_{FU}$	–	0.9	1.3	V	$I_F = 0.5\text{ A}$
Lower	$V_{FL}$	–	0.9	1.3	V	$I_F = 0.5\text{ A}$

#### Inhibit Input

H-input voltage threshold	$V_{IH}$	–	0.52	0.7	$V_{CC}$	–
L-input voltage threshold	$V_{IL}$	0.2	0.48	–	$V_{CC}$	–
Hysteresis of input voltage	$V_{IHY}$	50	200	500	mV	–
Pull down current	$I_I$	5	25	100	$\mu\text{A}$	$V_I = 0.2 \times V_{CC}$
Input capacitance	$C_I$	–	10	15	pF	$0\text{ V} < V_{CC} < 5.25\text{ V}$

### 2.3 Electrical Characteristics (cont'd)

8 V <  $V_S$  < 40 V; 4.75 V <  $V_{CC}$  < 5.25 V; INH = High; all outputs open;  $-40\text{ }^\circ\text{C} < T_j < 150\text{ }^\circ\text{C}$ ;  
unless otherwise specified

Parameter	Symbol	Limit Values			Unit	Test Condition
		min.	typ.	max.		

*Note: Capacitances are guaranteed by design.*

#### SPI-Interface

##### Delay Time from Stand-by to Data In/Power on Reset

Setup time	$t_{\text{set}}$	–	–	100	$\mu\text{s}$	–
------------	------------------	---	---	-----	---------------	---

##### Logic Inputs DI, CLK and CSN

H-input voltage threshold	$V_{\text{IH}}$	–	0.52	0.7	$V_{\text{CC}}$	–
L-input voltage threshold	$V_{\text{IL}}$	0.2	0.48	–	$V_{\text{CC}}$	–
Hysteresis of input voltage	$V_{\text{IHY}}$	50	200	500	mV	–
Pull up current at pin CSN	$I_{\text{ICSN}}$	– 50	– 25	– 10	$\mu\text{A}$	$V_{\text{CSN}} = 0.7 \times V_{\text{CC}}$
Pull down current at pin DI	$I_{\text{IDI}}$	10	25	50	$\mu\text{A}$	$V_{\text{DI}} = 0.2 \times V_{\text{CC}}$
Pull down current at pin CLK	$I_{\text{ICLK}}$	10	25	50	$\mu\text{A}$	$V_{\text{CLK}} = 0.2 \times V_{\text{CC}}$
Input capacitance at pin CSN, DI or CLK	$C_{\text{I}}$	–	10	15	pF	$0\text{ V} < V_{\text{CC}} < 5.25\text{ V}$

*Note: Capacitances are guaranteed by design.*

##### Logic Output DO

H-output voltage level	$V_{\text{DOH}}$	$V_{\text{CC}} - 1.0$	$V_{\text{CC}} - 0.7$	–	V	$I_{\text{DOH}} = 1\text{ mA}$
L-output voltage level	$V_{\text{DOL}}$	–	0.2	0.4	V	$I_{\text{DOL}} = -1.6\text{ mA}$
Tri-state leakage current	$I_{\text{DOLK}}$	– 10	0	10	$\mu\text{A}$	$V_{\text{CSN}} = V_{\text{CC}}$ $0\text{ V} < V_{\text{DO}} < V_{\text{CC}}$
Tri-state input capacitance	$C_{\text{DO}}$	–	10	15	pF	$V_{\text{CSN}} = V_{\text{CC}}$ $0\text{ V} < V_{\text{CC}} < 5.25\text{ V}$

*Note: Capacitances are guaranteed by design.*

### 2.3 Electrical Characteristics (cont'd)

8 V <  $V_S$  < 40 V; 4.75 V <  $V_{CC}$  < 5.25 V; INH = High; all outputs open;  $-40\text{ }^\circ\text{C} < T_j < 150\text{ }^\circ\text{C}$ ;  
unless otherwise specified

Parameter	Symbol	Limit Values			Unit	Test Condition
		min.	typ.	max.		

#### Data Input Timing

Clock period	$t_{pCLK}$	1000	–	–	ns	–
Clock high time	$t_{CLKH}$	500	–	–	ns	–
Clock low time	$t_{CLKL}$	500	–	–	ns	–
Clock low before CSN low	$t_{bef}$	500	–	–	ns	–
CSN setup time	$t_{lead}$	500	–	–	ns	–
CLK setup time	$t_{lag}$	500	–	–	ns	–
Clock low after CSN high	$t_{beh}$	500	–	–	ns	–
DI setup time	$t_{DISU}$	250	–	–	ns	–
DI hold time	$t_{DIHO}$	250	–	–	ns	–
Input signal rise time at pin DI, CLK and CSN	$t_{rIN}$	–	–	200	ns	–
Input signal fall time at pin DI, CLK and CSN	$t_{fIN}$	–	–	200	ns	–

#### Data Output Timing

DO rise time	$t_{rDO}$	–	50	100	ns	$C_L = 100\text{ pF}$
DO fall time	$t_{fDO}$	–	50	100	ns	$C_L = 100\text{ pF}$
DO enable time	$t_{ENDO}$	–	–	250	ns	low impedance
DO disable time	$t_{DISDO}$	–	–	250	ns	high impedance
DO valid time	$t_{VADO}$	–	100	250	ns	$V_{DO} < 0.2 V_{CC}$ ; $V_{DO} > 0.7 V_{CC}$ ; $C_L = 100\text{ pF}$

#### Thermal Prewarning and Shutdown

Thermal prewarning junction temperature	$T_{jPW}$	120	145	170	$^\circ\text{C}$	–
--	-----------	-----	-----	-----	------------------	---

### 2.3 Electrical Characteristics (cont'd)

8 V <  $V_S$  < 40 V; 4.75 V <  $V_{CC}$  < 5.25 V; INH = High; all outputs open;  $-40\text{ }^\circ\text{C} < T_j < 150\text{ }^\circ\text{C}$ ; unless otherwise specified

Parameter	Symbol	Limit Values			Unit	Test Condition
		min.	typ.	max.		
Temperature prewarning hysteresis	$\Delta T$	–	30	–	K	–
Thermal shutdown junction temperature	$T_{jSD}$	150	175	200	$^\circ\text{C}$	–
Thermal switch-on junction temperature	$T_{jSO}$	120	–	170	$^\circ\text{C}$	–
Temperature shutdown hysteresis	$\Delta T$	–	30	–	K	–
Ratio of SD to PW temperature	$T_{jSD}/T_{jPW}$	1.05	1.20	–	–	–

*Note: Temperatures are guaranteed by design.*

*The listed characteristics are ensured over the operating range of the integrated circuit. Typical characteristics specify mean values expected over the production spread. If not otherwise specified, typical characteristics apply at  $T_A = 25\text{ }^\circ\text{C}$  and the given supply voltage.*

### 3 Timing Diagrams

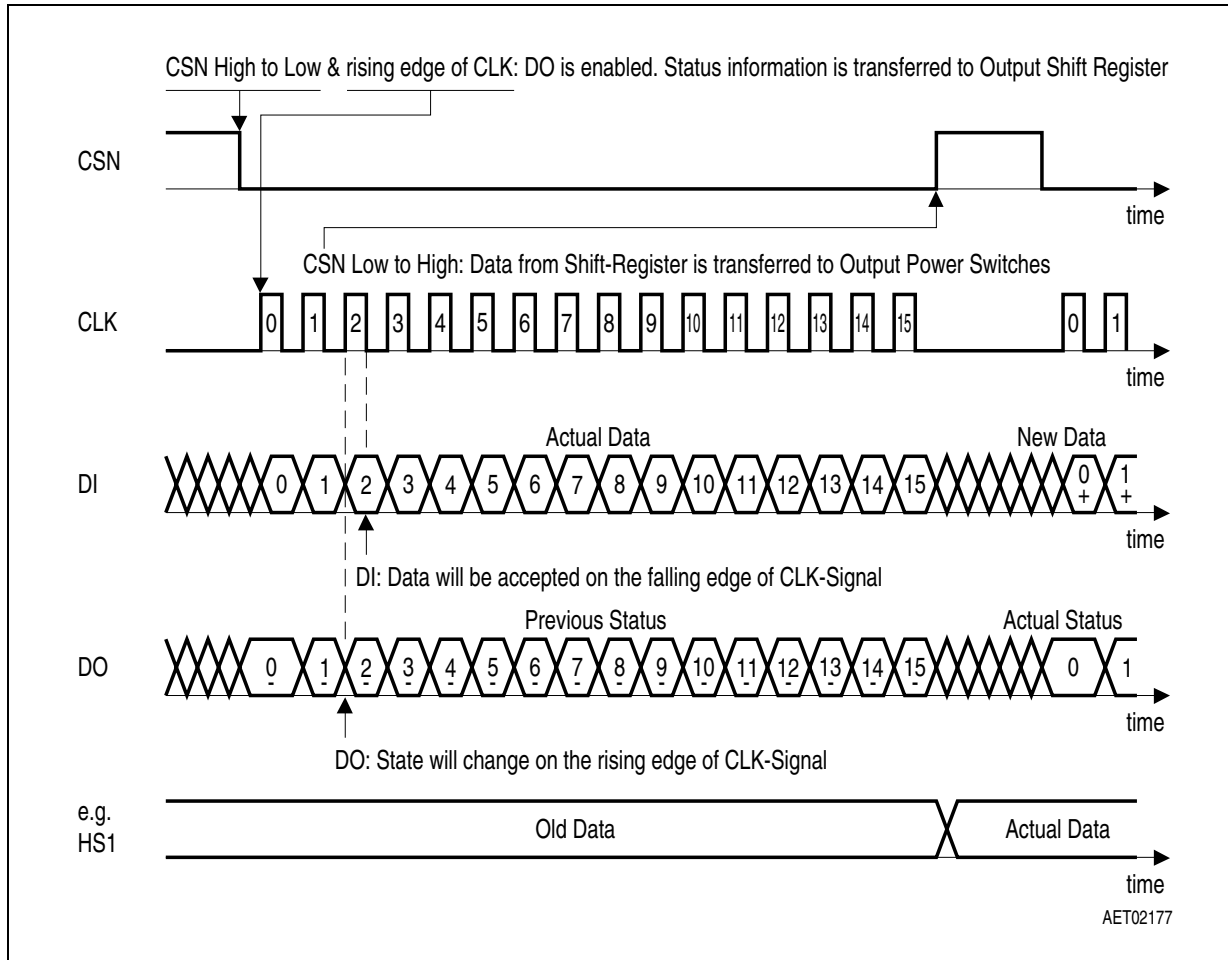

**Figure 3 Data Transfer Timing**

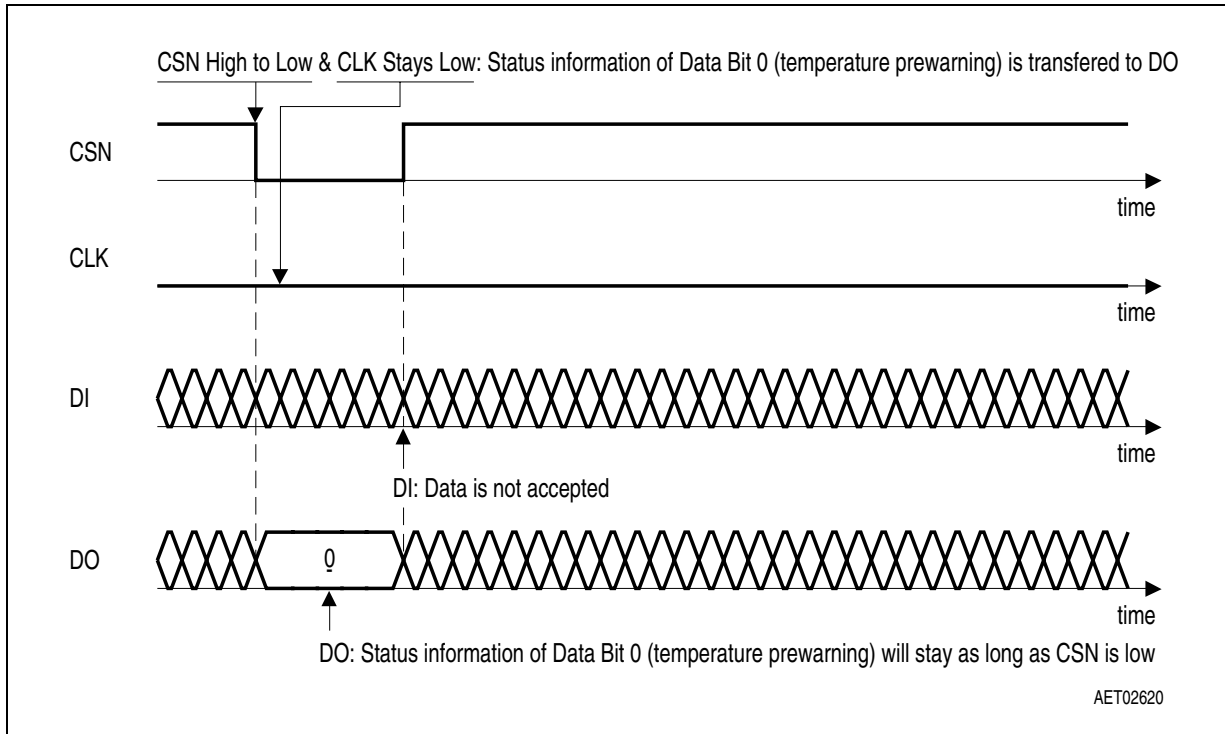

**Figure 4 Timing for Temperature Prewarning only**

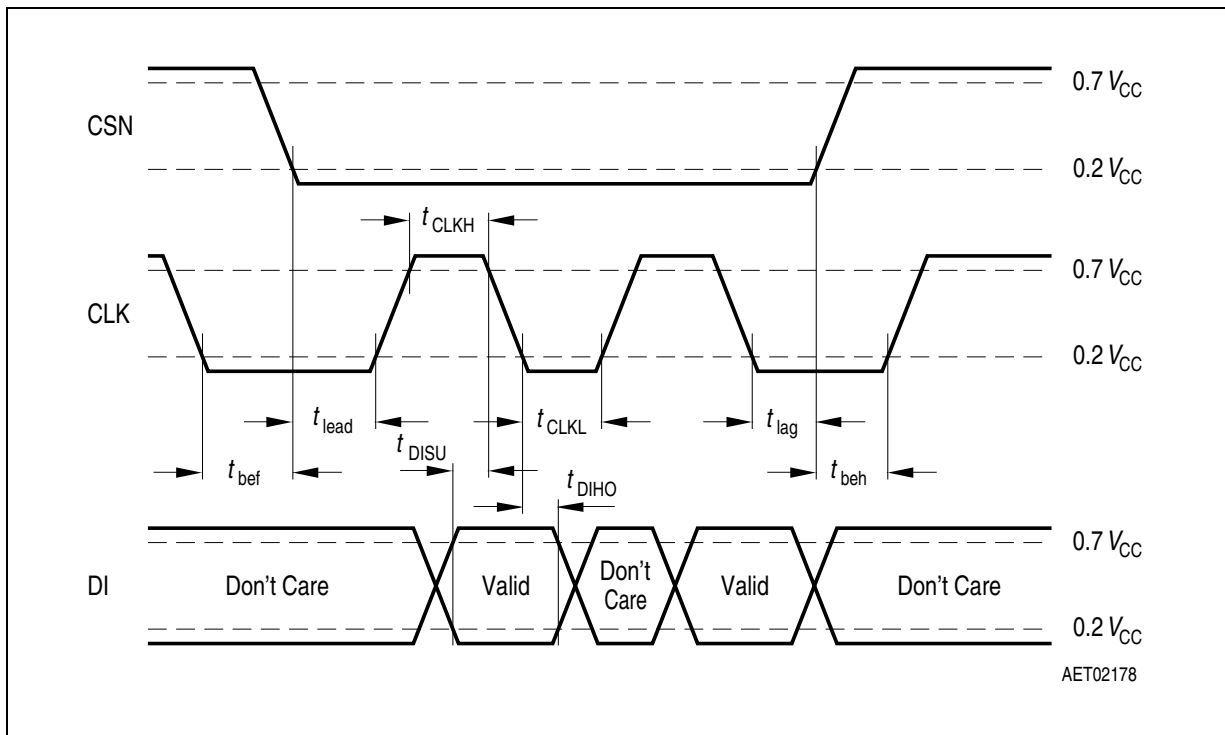

**Figure 5 SPI-Input Timing**



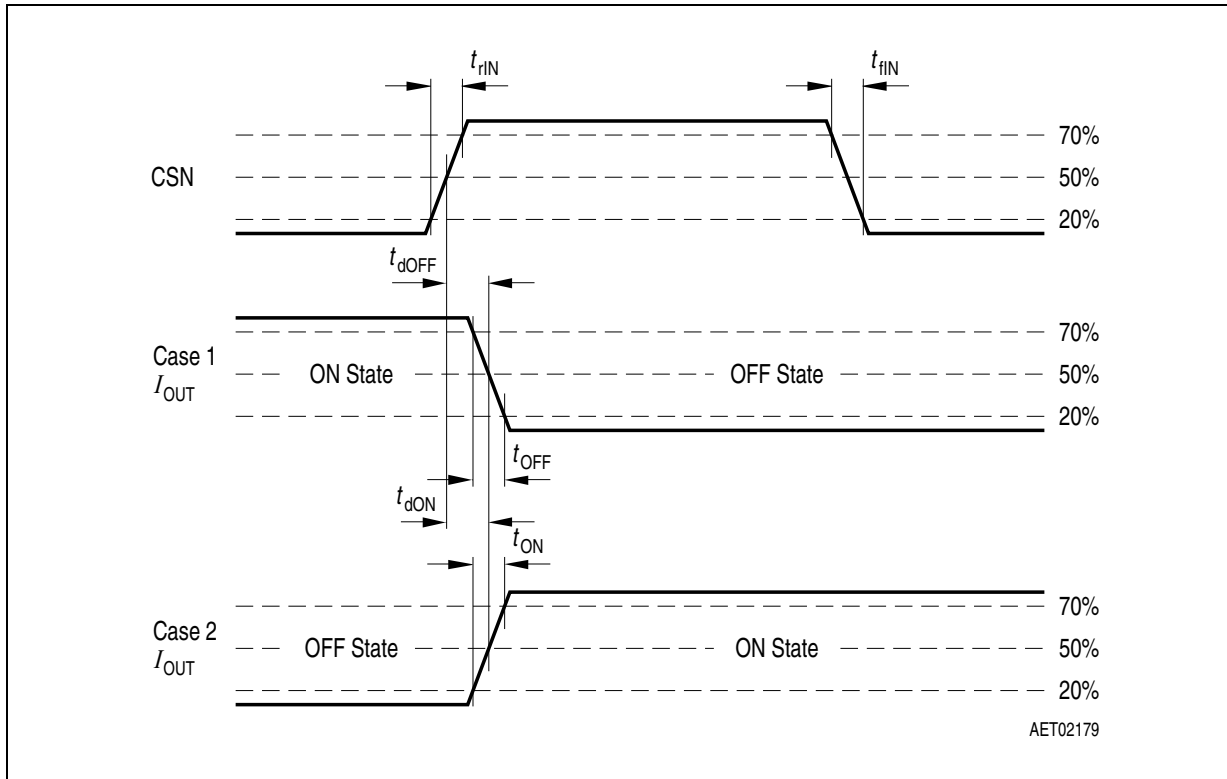

Figure 6 Turn OFF/ON Time

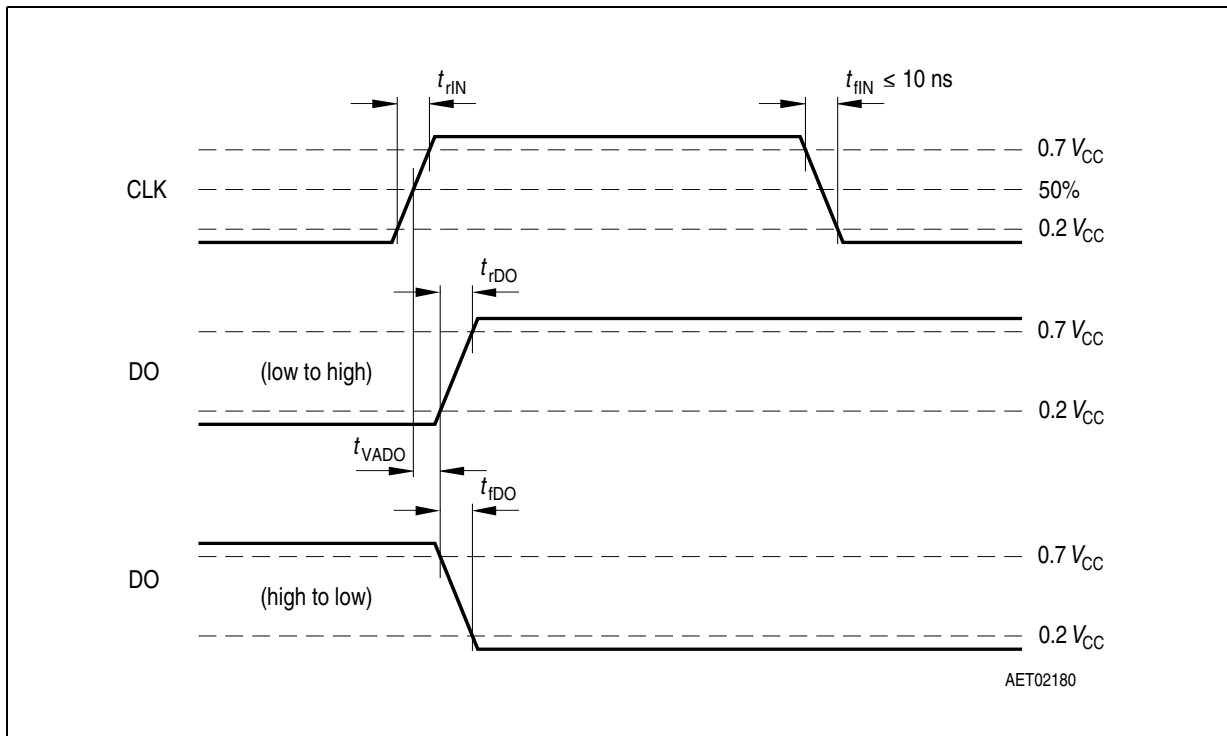

Figure 7 DO Valid Data Delay Time and Valid Time

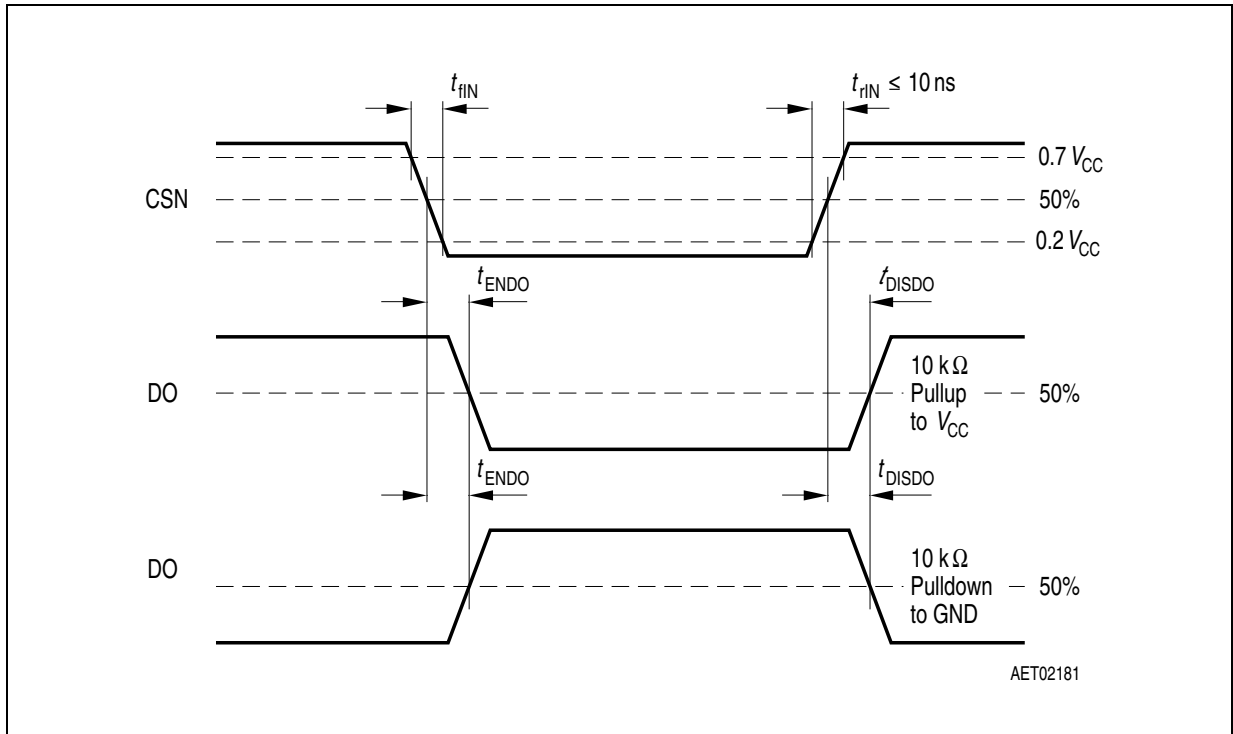

Figure 8 DO Enable and Disable Time

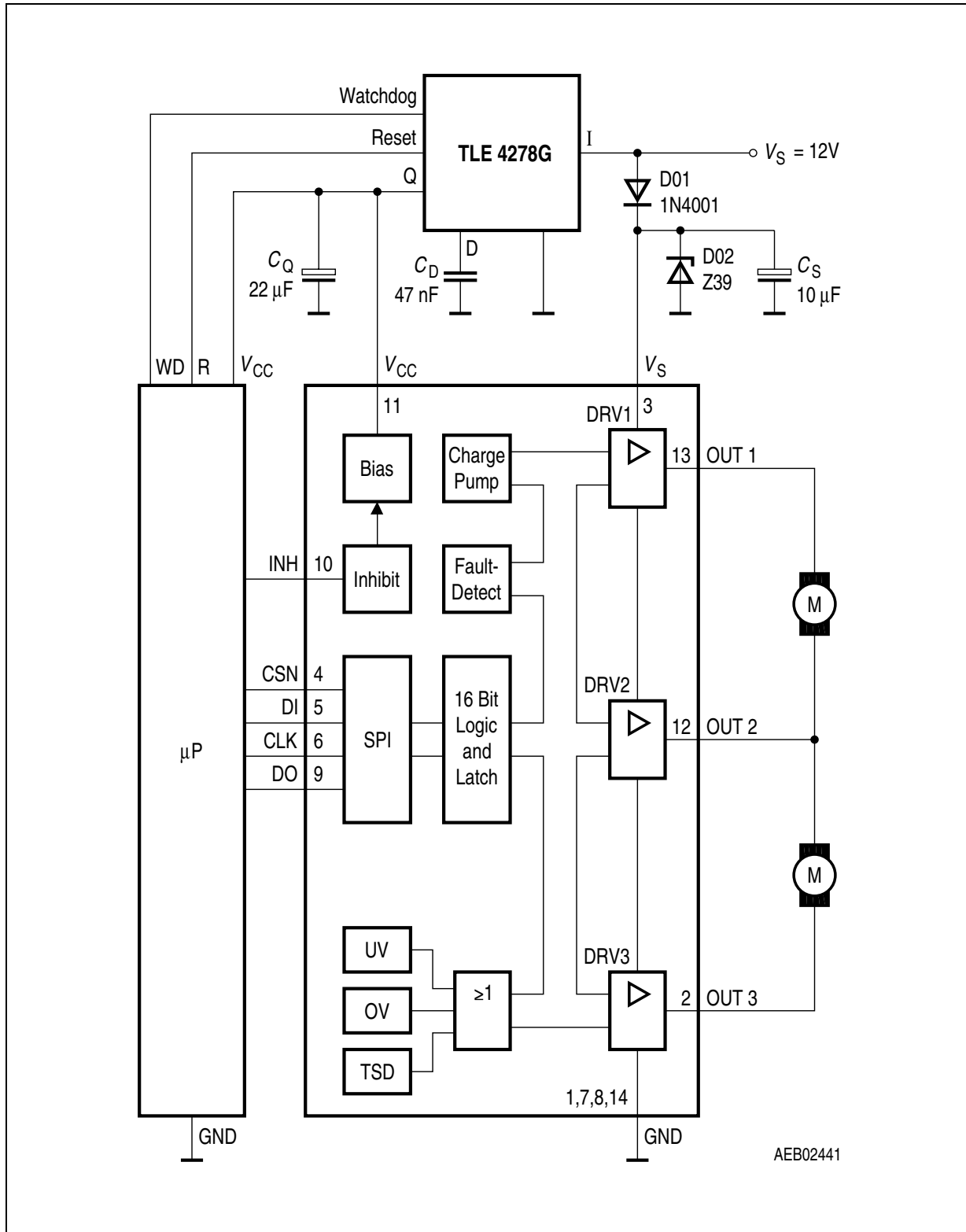
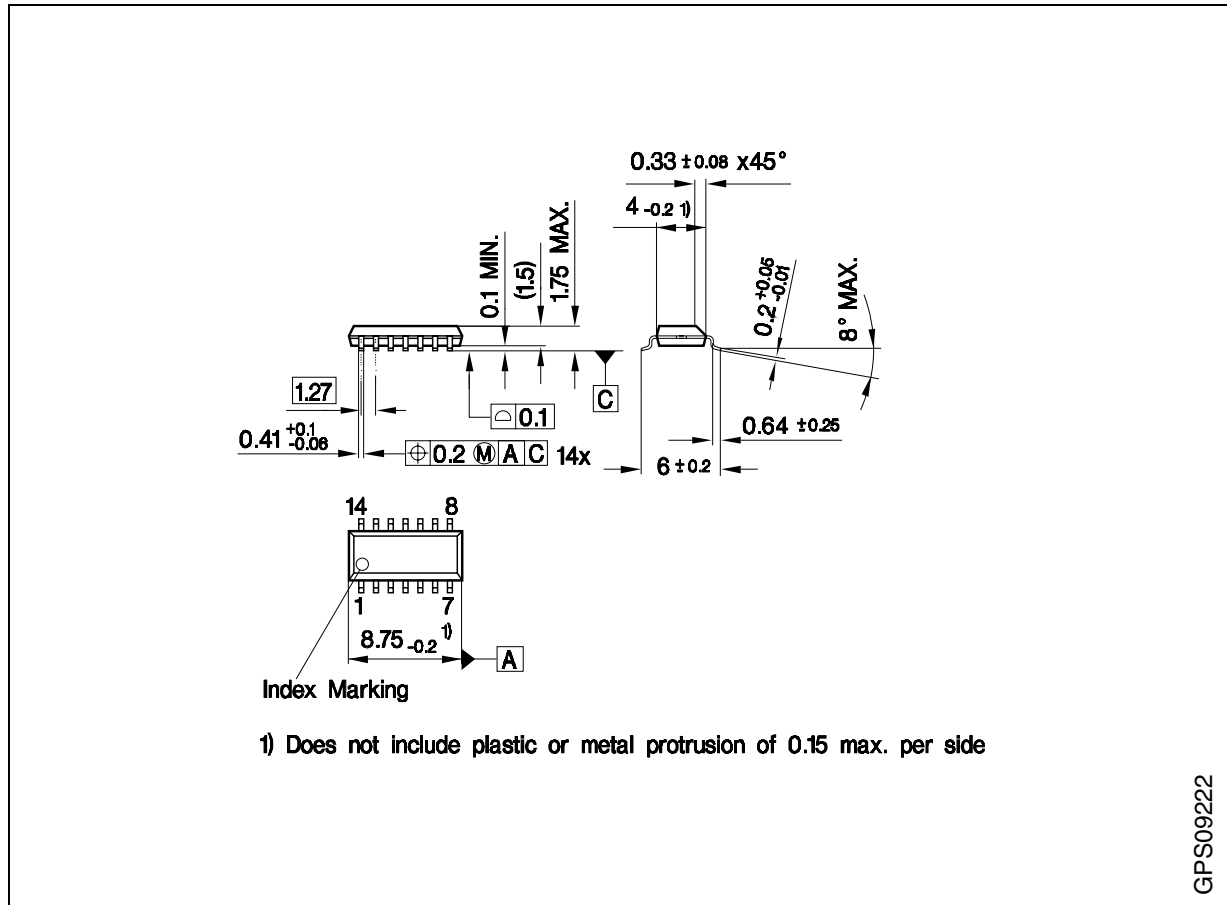

Figure 9 Application Circuit

## 4 Package Outlines



**Figure 10 PG-DSO-14-35 (Plastic Dual Small Outline)**

### Green Product (RoHS compliant)

To meet the world-wide customer requirements for environmentally friendly products and to be compliant with government regulations the device is available as a green product. Green products are RoHS-Compliant (i.e Pb-free finish on leads and suitable for Pb-free soldering according to IPC/JEDEC J-STD-020).

You can find all of our packages, sorts of packing and others in our Infineon Internet Page "Products": <http://www.infineon.com/products>.

SMD = Surface Mounted Device

Dimensions in mm

## Revision History

Version	Date	Changes
Rev. 1.1	2007-09-12	<p>RoHS-compliant version of the TLE 6208-3 G</p> <ul style="list-style-type: none"><li>• All pages: Infineon logo updated</li><li>• Page 1: “added AEC qualified” and “RoHS” logo, “Green Product (RoHS compliant)” and “AEC qualified” statement added to feature list, package name changed to RoHS compliant versions, package picture updated, ordering code removed</li><li>• Page 20: Package name changed to RoHS compliant versions, “Green Product” description added</li><li>• Page 21-22: added Revision History and Legal Disclaimer</li></ul>

**Edition 2007-08-20**

**Published by  
Infineon Technologies AG  
81726 Munich, Germany**

**© 9/14/07 Infineon Technologies AG  
All Rights Reserved.**

#### **Legal Disclaimer**

The information given in this document shall in no event be regarded as a guarantee of conditions or characteristics. With respect to any examples or hints given herein, any typical values stated herein and/or any information regarding the application of the device, Infineon Technologies hereby disclaims any and all warranties and liabilities of any kind, including without limitation, warranties of non-infringement of intellectual property rights of any third party.

#### **Information**

For further information on technology, delivery terms and conditions and prices, please contact the nearest Infineon Technologies Office ([www.infineon.com](http://www.infineon.com)).

#### **Warnings**

Due to technical requirements, components may contain dangerous substances. For information on the types in question, please contact the nearest Infineon Technologies Office.

Infineon Technologies components may be used in life-support devices or systems only with the express written approval of Infineon Technologies, if a failure of such components can reasonably be expected to cause the failure of that life-support device or system or to affect the safety or effectiveness of that device or system. Life support devices or systems are intended to be implanted in the human body or to support and/or maintain and sustain and/or protect human life. If they fail, it is reasonable to assume that the health of the user or other persons may be endangered.