

Optical Sensor LTR-659PS-01

1. Description

The LTR-659PS-01 is an integrated low voltage I2C digital proximity sensor [PS] with built-in emitter, in a single miniature chip lead-free surface mount package. With built-in proximity sensor (emitter and detector), LTR-659PS-01 offers the feature to detect object at a user configurable distance.

The sensor supports an interrupt feature that removes the need to poll the sensor for a reading which improves system efficiency. The sensor also supports several features that help to minimize the occurrence of false triggering. This CMOS design and factory-set one time trimming capability ensure minimal sensor-to-sensor variations for ease of manufacturability to the end customers.

2. Features

- I2C interface (Fast Mode @ 400kbit/s)
- Ultra-small ChipLED package
- Built-in temperature compensation circuit
- Low active power consumption with standby mode
- Supply voltage range from 2.4V to 3.6V capable of 1.7V logic voltage
- Operating temperature range from -30 °C to +70 °C
- RoHS and Halogen free compliant
- Proximity Sensor
 - Built-in LED driver, emitter and detector
 - Programmable LED drive settings
 - 11-bit effective resolution
 - High ambient light suppression

3. Applications

To detect and control display backlight in presence of object in

- Mobile Devices: Mobile phone, PDA
- Computing Devices: Notebook PC, Desktop Monitor
- Consumer Devices: LCD/PDP TV backlight systems, Cameras, Personal Navigation Device, Digital Photo Frame
- Dashboard

**Optical Sensor
LTR-659PS-01**

4. Ordering Information

Part Number	Packaging Type	Package	Quantity
LTR-659PS-01	Tape and Reel	8-pins chipled package	8000

5. Outline Dimensions

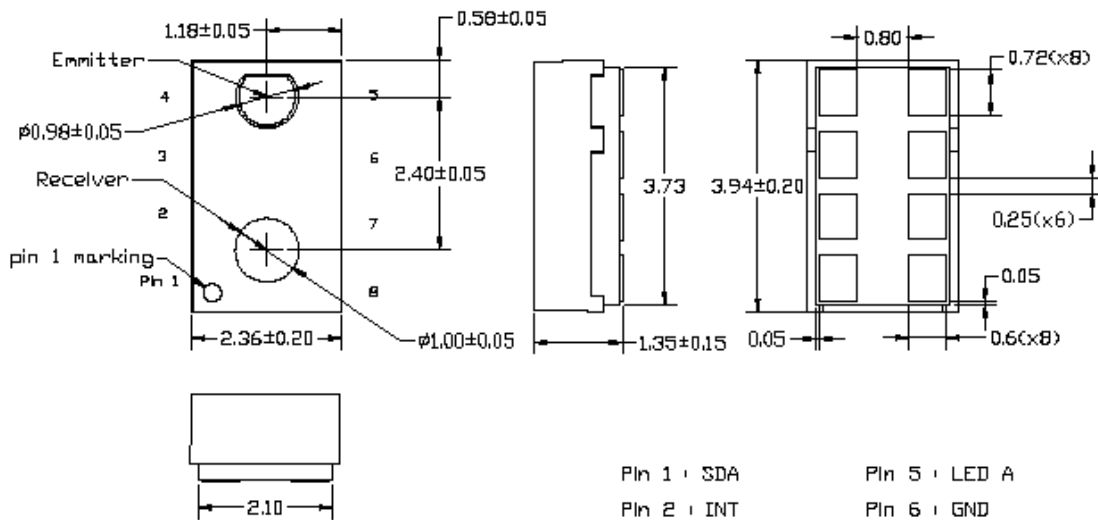

Pin 1 : SDA	Pin 5 : LED A
Pin 2 : INT	Pin 6 : GND
Pin 3 : LDR	Pin 7 : SCL
Pin 4 : LED K	Pin 8 : VDD

Notes :

1. All dimensions are in millimeters.

Optical Sensor LTR-659PS-01

6. Functional Block Diagram

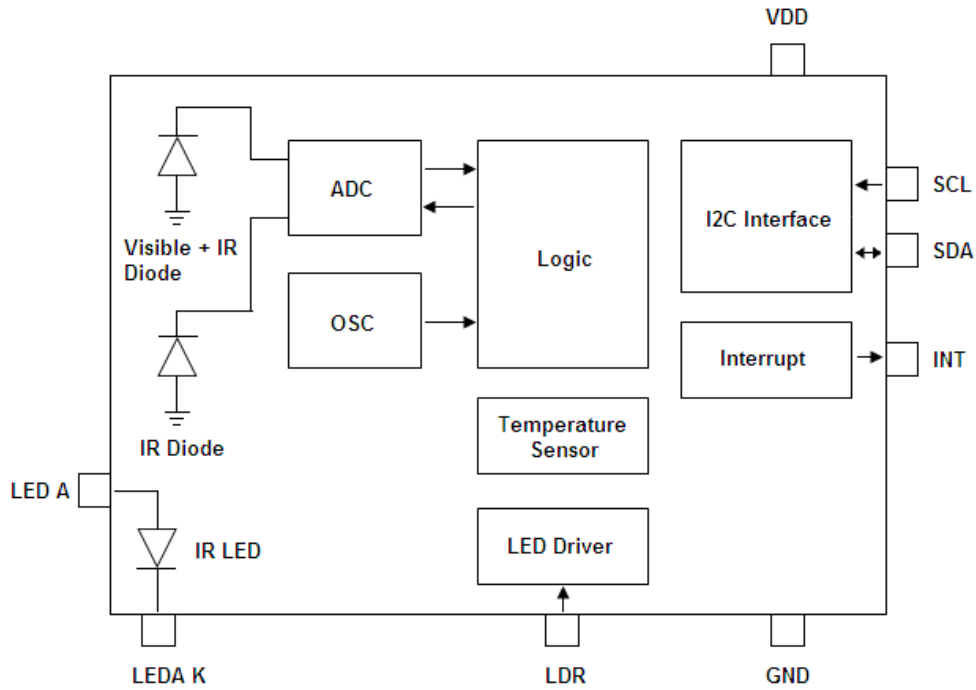

7. Application Circuit

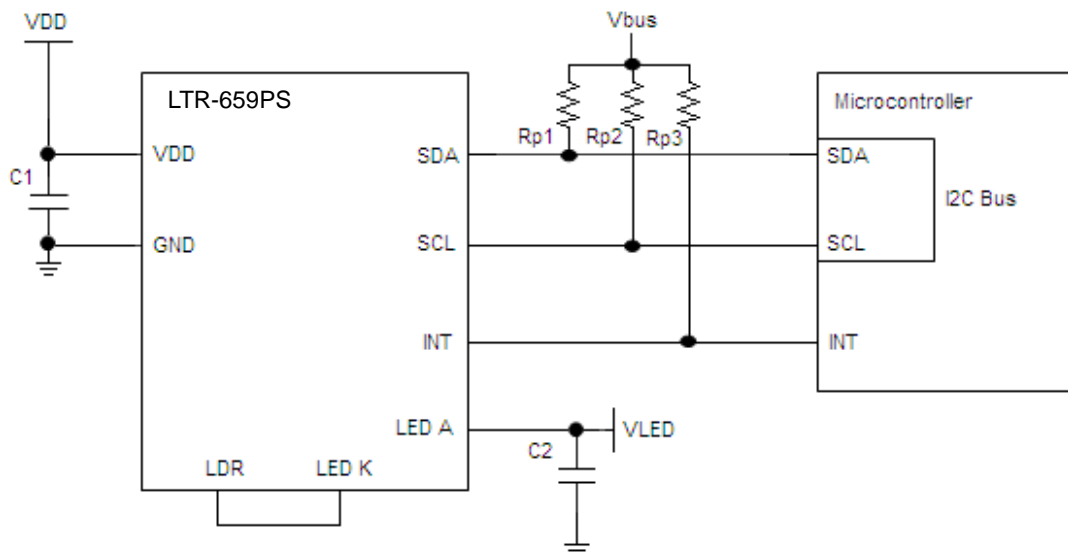

Optical Sensor LTR-659PS-01

I/O Pins Configuration Table

Pin	I/O Type	Symbol	Description
1	I/O	SDA	I ² C serial data. This pin is an open drain input / output.
2	O	INT	Level Interrupt Pin. This pin is an open drain output.
3	I	LDR	LED Driver for proximity emitter. This pin is an open drain input.
4	O	LED K	LED Cathode. Connect to LDR pin if using internal LED driver circuit.
5	I	LED A	LED Anode. Connect to VDD or VBAT on PCB
6		GND	Ground
7	I	SCL	I ² C serial clock. This pin is an open drain input.
8		VDD	Power Supply Voltage

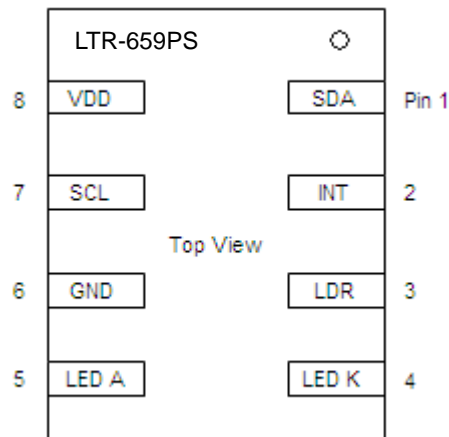

Recommended Application Circuit Components

Component	Recommended Value
Rp1, Rp2, Rp3 [1]	1 kΩ to 10 kΩ
C1, C2	1uF ±20%, X7R Ceramic

Optical Sensor LTR-659PS-01

8. Ratings and Specifications

Absolute Maximum Ratings at Ta = 25°C

Parameter	Symbol	Rating	Unit
Supply Voltage	VDD	3.8	V
Digital Voltage Range	SCL, SDA, INT	-0.5 to 3.8	V
Digital Output Current	SCL, SDA, INT	-1 to 20	mA
Storage Temperature	T _{stg}	-40 to 100	°C

Note: Exceeding these ratings could cause damage to the sensor. All voltages are with respect to ground. Currents are positive into, negative out of the specified terminal.

Recommended Operating Conditions

Description	Symbol	Min.	Typ.	Max.	Unit
Supply Voltage	VDD	2.4		3.6	V
LED Supply Voltage	VLED	2.5		4.35	V
Interface Bus Power Supply Voltage	V _{IO}	1.7		3.6	V
Operating Temperature	T _{ope}	-30		70	°C

Electrical & Optical Specifications

All specifications are at VDD = 3.0V, T_{ope} = 25°C, unless otherwise noted.

Parameter	Min.	Typ.	Max.	Unit	Condition
Active Supply Current			250	uA	Active Mode, T _{ope} = 25°C
Standby Current			5	uA	Standby / Sleep Mode
Initial Startup Time	60	100	1000	ms	(Note 1)
Wakeup Time from Standby			10	ms	(Note 1)

Optical Sensor LTR-659PS-01

Proximity Sensor

Parameter	Min.	Typ.	Max.	Unit	Condition
Full Scale ADC Count			2047	count	
Peak Sensitivity	840	855	870	nm	
Detection Distance	20			mm	100mA, 4 pulses, 18% Gray Card
Ambient Light Suppression			50k	lux	Direct sunlight
LED Pulse Count	1		15	pulses	
LED Pulse Frequency	30k		100k	Hz	Increment of 10k Hz
LED Duty Cycle	25		100	%	Increment of 25%
LED Peak Current		5		mA	LED Peak Current = 000
		10		mA	LED Peak Current = 001
		20		mA	LED Peak Current = 010
		50		mA	LED Peak Current = 011
		100		mA	LED Peak Current = 1XX
Optical Rise / Fall Time	100			ns	

Notes:

1. Startup Sequence

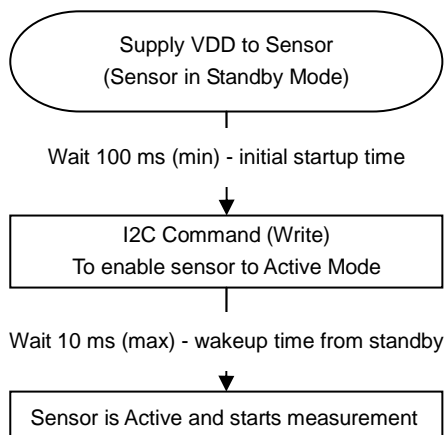

Optical Sensor LTR-659PS-01

AC Electrical Characteristics

All specifications are at VBus = 1.8V, T_{ope} = 25°C, unless otherwise noted.

Parameter	Symbol	Min.	Max.	Unit
SCL clock frequency	f_{SCL}	1	400	kHz
Bus free time between a STOP and START condition	t_{BUF}	1.3		us
Hold time (repeated) START condition. After this period, the first clock pulse is generated	$t_{HD;STA}$	0.6		us
LOW period of the SCL clock	t_{LOW}	1.3		us
HIGH period of the SCL clock	t_{HIGH}	0.6		us
Set-up time for a repeated START condition	$t_{SU;STA}$	0.6		us
Set-up time for STOP condition	$t_{SU;STO}$	0.6		us
Rise time of both SDA and SCL signals	t_r	30	300	ns
Fall time of both SDA and SCL signals	t_f	30	300	ns
Data hold time	$t_{HD;DAT}$	0.3	0.9	us
Data setup time	$t_{SU;DAT}$	100		ns
Pulse width of spikes which must be suppressed by the input filter	t_{SP}	0	50	ns

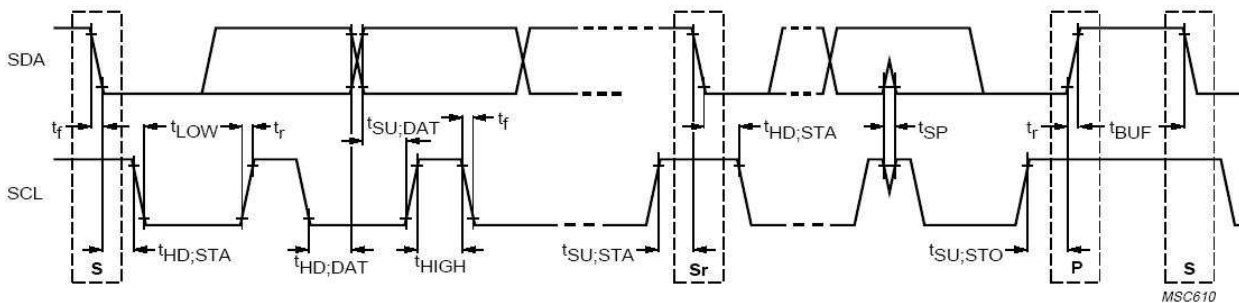

Definition of timing for I²C bus

9. Principles of Operation

I²C Protocols

• I²C Write Protocol (type 1):

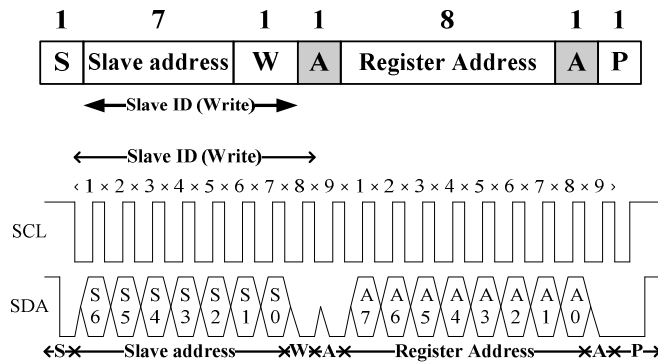

• I²C Write Protocol (type 2):

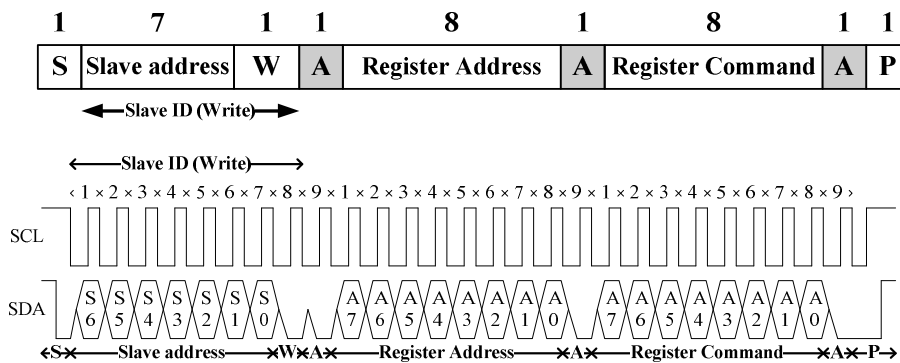

• I²C Read Protocol:

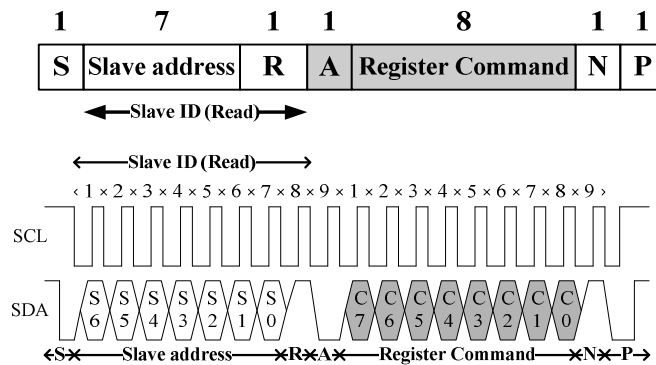

Optical Sensor LTR-659PS-01

· I²C Read (Combined format) Protocol:

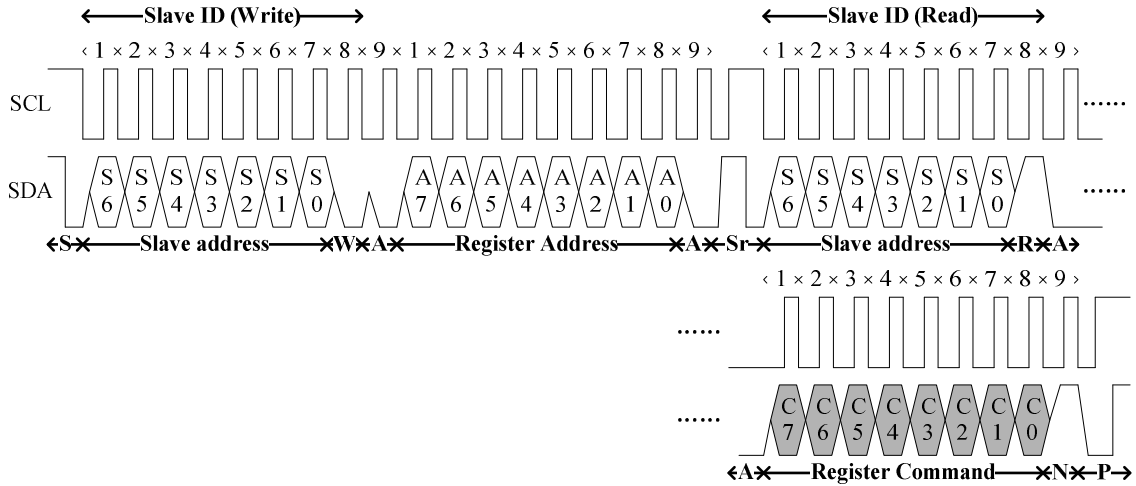
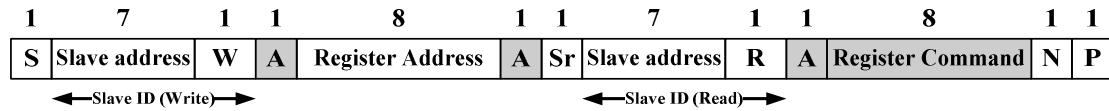

- | | |
|---|---|
| <p>A Acknowledge (0 for an ACK)</p> <p>S Start condition</p> <p>P Stop condition</p> <p>W Write (0 for writing)</p> <p> Slave-to-master</p> | <p>N Non-Acknowledge (1 for an NACK)</p> <p>Sr Repeated Start condition</p> <p>R Read (1 for read)</p> <p> Master-to-Slave</p> |
|---|---|

I²C Slave Address

The 7 bits slave address for this sensor is 0x23H. A read/write bit should be appended to the slave address by the master device to properly communicate with the sensor.

I ² C Slave Address									
Command Type	(0x23H)							W/R	value
	Bit7	Bit6	Bit5	Bit4	Bit3	Bit2	Bit1	Bit0	
Write	0	1	0	0	0	1	1	0	0x46H
Read	0	1	0	0	0	1	1	1	0x47H

Optical Sensor LTR-659PS-01

Register Set

Address	R / W	Register Name	Description	Reset Value
0x80	R / W	SW_RESET	SW reset	0x00
0x81	R / W	PS_CONTR	PS operation mode control	0x00
0x82	R / W	PS_LED	PS LED setting	0x7F
0x83	R / W	PS_N_PULSES	PS number of pulses	0x01
0x84	R / W	PS_MEAS_RATE	PS measurement rate in active mode	0x02
0x85	R / W	RESERVED	Reserved	0x03
0x86	R	PART_ID	Part Number ID and Revision ID	0x92
0x87	R	MANUFAC_ID	Manufacturer ID	0x05
0x88	R	RESERVED	Reserved	0x00
0x89	R	RESERVED	Reserved	0x00
0x8A	R	RESERVED	Reserved	0x00
0x8B	R	RESERVED	Reserved	0x00
0x8C	R	PS_STATUS	PS new data status	0x00
0x8D	R	PS_DATA_0	PS measurement data, lower byte	0x00
0x8E	R	PS_DATA_1	PS measurement data, upper byte	0x00
0x8F	R / W	INTERRUPT	Interrupt settings	0x00
0x90	R / W	PS_THRES_UP_0	PS interrupt upper threshold, lower byte	0xFF
0x91	R / W	PS_THRES_UP_1	PS interrupt upper threshold, upper byte	0x07
0x92	R / W	PS_THRES_LOW_0	PS interrupt lower threshold, lower byte	0x00
0x93	R / W	PS_THRES_LOW_1	PS interrupt lower threshold, upper byte	0x00
0x94	R/W	PS_OFFSET_1	PS offset, upper byte	0x00
0x95	R/W	PS_OFFSET_0	PS offset, lower byte	0x00
0x97	R / W	RESERVED	Reserved	0xFF
0x98	R / W	RESERVED	Reserved	0xFF
0x99	R / W	RESERVED	Reserved	0x00
0x9A	R / W	RESERVED	Reserved	0x00
0x9E	R / W	INTERRUPT PERSIST	PS Interrupt persist setting	0x00

Notes:

1. When reading PS data registers, read sequence should always be from lower address to higher address (E.g. read 0x8D first then 0x8E)
2. When setting of INTERRUPT register (0x8F) is necessary, it should be done before the device is in Active mode.
3. Reserved registers should not be written with any value other than its default value.

Optical Sensor LTR-659PS-01

SW_RESET Register (0x80)

The SW_RESET register controls the software (SW) reset for the sensor.

0x80	SW_RESET (default = 0x00)							
	B7	B6	B5	B4	B3	B2	B1	B0
	Reserved						SW Reset	Reserved

Field	Bits	Default	Type	Description	
Reserved	7:2	000000	--	--	--
SW reset	1	0	RW	0	Initial start-up procedure is NOT started (default)
				1	Initial start-up procedure is started, bit has default value of 0 after start-up
Reserved	0	0	--	--	--

PS_CONTR Register (0x81)

The PS_CONTR register controls the PS operation modes. The PS sensor can be set to either standby mode or active mode. At either of these modes, the I²C circuitry is always active. The default mode after power up is standby mode. During standby mode, there is no PS measurement performed but I²C communication is allowed to enable read/write to all the registers. PS Gain controls the gain setting for the PS sensor. PS Saturation Indicator Enable bit is used for enabling the saturation indicator in Bit 7 of PS_DATA register (0x8E).

0x81	PS_CONTR (default = 0x00)							
	B7	B6	B5	B4	B3	B2	B1	B0
	Reserved		PS Saturation Indicator Enable	Reserved	PS Gain		PS Mode	

Optical Sensor

LTR-659PS-01

Field	Bits	Default	Type	Description	
Reserved	7:6	00	--	--	Must be 0
PS Saturation Indicator Enable	5	0	R/W	0	Saturation indicator disable
				1	Saturation indicator enable
Reserved	4	0	--	--	Must be 0
PS Gain	3:2	00	RW	00	X16 (default)
				10	X32
				X1	X64
PS Mode	1:0	00	RW	00	Stand-by mode (default)
				01	
				10	Active mode
				11	

Optical Sensor LTR-659PS-01

PS_LED Register (0x82)

The PS_LED register controls the LED pulse modulation frequency, LED current duty cycle and LED peak current.

0x82	PS_LED (default = 0x7F)							
	B7	B6	B5	B4	B3	B2	B1	B0
	LED Pulse Frequency			LED Duty Cycle		LED Peak Current		

Field	Bits	Default	Type	Description	
LED pulse Modulation Frequency	7:5	011	RW	000	LED pulse period = 30kHz
				001	LED pulse period = 40kHz
				010	LED pulse period = 50kHz
				011	LED pulse period = 60kHz (default)
				100	LED pulse period = 70kHz
				101	LED pulse period = 80kHz
				110	LED pulse period = 90kHz
				111	LED pulse period = 100kHz
LED Current DUTY	4:3	11	RW	00	DUTY = 25%
				01	DUTY = 50%
				10	DUTY = 75%
				11	DUTY = 100% (default)
LED current	2:0	111	RW	000	LED pulsed current level = 5mA
				001	LED pulsed current level = 10mA
				010	LED pulsed current level = 20mA
				011	LED pulsed current level = 50mA
				100	LED pulsed current level = 100mA (default)
				101	
				110	
				111	

Optical Sensor LTR-659PS-01

PS_N_Pulses Register (0x83)

The PS_N_Pulses register controls the number of LED pulses to be emitted.

0x83	PS_N_Pulses (default = 0x01)							
	B7	B6	B5	B4	B3	B2	B1	B0
	<i>Reserved</i>				<i>LED Pulse Count</i>			

Field	Bits	Default	Type	Description	
PS number of LED pulses	7:4	0000	RW	0000 (default) RESERVED (Write only 0000)	
	3:0	0001	RW	0000	RESERVED
				0001	Number of pulses = 1 (default)
				0010	Number of pulses = 2
				0011	Number of pulses = 3
				0100	Number of pulses = 4
				0101	Number of pulses = 5
				0110	Number of pulses = 6
				0111	Number of pulses = 7
				1000	Number of pulses = 8
				1001	Number of pulses = 9
				1010	Number of pulses = 10
				1011	Number of pulses = 11
				1100	Number of pulses = 12
				1101	Number of pulses = 13
1110	Number of pulses = 14				
1111	Number of pulses = 15				

Optical Sensor LTR-659PS-01

PS_MEAS_RATE Register (0x84)

The PS_MEAS_RATE register controls the timing of the periodic measurements of the PS in active mode. PS Measurement Repeat Rate is the interval between PS_DATA registers update.

0x84	PS_MEAS_RATE (default = 0x02)							
	B7	B6	B5	B4	B3	B2	B1	B0
	<i>Reserved</i>				<i>PS Measurement Repeat Rate</i>			

Field	Bits	Default	Type	Description	
Reserved	7:4	0000	--	--	--
PS measurement rate	3:0	0010	RW	0000	50ms
				0001	70ms
				0010	100ms (default)
				0011	200ms
				0100	500ms
				0101	1000ms
				0110	2000ms
				0111	
1XXX	10ms				

Optical Sensor LTR-659PS-01

PART_ID Register (0x86) (Read Only)

The PART_ID register defines the part number and revision identification of the sensor.

0x86	PART_ID (default = 0x92)							
	B7	B6	B5	B4	B3	B2	B1	B0
	<i>Part Number ID</i>				<i>Revision ID</i>			

Field	Bits	Default	Type	Description
Part Number ID	7:4	1001	R	--
Revision ID	3:0	0010	R	--

MANUFAC_ID Register (0x87) (Read Only)

The MANUFAC_ID register defines the manufacturer identification of the sensor.

0x87	MANUFAC_ID (default = 0x05)							
	B7	B6	B5	B4	B3	B2	B1	B0
	<i>Manufacturer ID</i>							

Field	Bits	Default	Type	Description
Manufacturer ID	7:0	00000101	R	Manufacturer ID (0x05H)

Optical Sensor LTR-659PS-01

PS_STATUS Register (0x8C) (Read Only)

The PS_STATUS register stores the information about interrupt status and PS data status. New data means data has not been read yet. When the measurement is completed and data is written to the data register, the data status bit will be set to logic 1. When the data register is read, the data status bit will be set to logic 0. Interrupt status determines if the PS interrupt criteria are met. It will check if the PS measurement data is outside of the range defined by the upper and lower threshold limits.

0x8C	PS_STATUS (default = 0x00)							
	B7	B6	B5	B4	B3	B2	B1	B0
	<i>Reserved</i>						<i>PS Interrupt Status</i>	<i>PS Data Status</i>

Field	Bits	Default	Type	Description	
Reserved	7:2	000000	--	--	--
PS interrupt status	1	0	R	0	interrupt signal INACTIVE (default)
				1	interrupt signal ACTIVE
PS data status	0	0	R	0	OLD data (data already read), (default)
				1	NEW data (first time data is being read)

PS_DATA_0 Register (0x8D / 0x8E) (Read Only)

The PS ADC channel data are expressed as a 11-bit data spread over two registers. The PS_DATA_0 and PS_DATA_1 registers provide the lower and upper byte respectively. When the I²C read operation starts, both the registers are locked until the I²C read operation is completed. This will ensure that the data in the registers is from the same measurement even if an additional integration cycle ends during the read operation. New measurement data is stored into temporary registers and the PS_DATA registers are updated as soon as there is no on-going I²C read operation.

PS Saturation Flag is used for monitoring the internal IC saturation. It will be flagged when the IC has reached saturation and not able to perform any further PS measurement. The PS Saturation Indicator Enable bit in PS_CONTR Register (0x81) has to be enabled in order to use this feature. If it is not enable, the flag will always be indicated as 0.

Optical Sensor LTR-659PS-01

0x8D	PS_DATA_0 (default = 0x00)							
	B7	B6	B5	B4	B3	B2	B1	B0
	<i>PS Data Low</i>							

0x8E	PS_DATA_1 (default = 0x00)							
	B7	B6	B5	B4	B3	B2	B1	B0
	<i>PS Saturation Flag</i>	<i>Reserved</i>				<i>PS Data High</i>		

Field	Address	Bits	Default	Type	Description	
PS Data, Low	0x8D	7:0	00000000	R	--	PS ADC lower byte data
PS Saturation Flag	0x8E	7	0	R	0	PS not saturated
					1	PS saturated
Reserved	0x8E	6:3	00000	--	--	--
PS Data, High	0x8E	2:0	000	R	--	PS ADC upper byte data

INTERRUPT Register (0x8F)

The INTERRUPT register controls the operation of the interrupt pin and functions. When the Interrupt Mode is set to 00, the INT output pin 2 is inactive / disabled and will not trigger any interrupt. However at this condition, the PS_STATUS register will still be updated. Note that when this register is to be set with values other than its default values, it should be set before device is in Active mode.

0x8F	INTERRUPT (default = 0x00)							
	B7	B6	B5	B4	B3	B2	B1	B0
	<i>Reserved</i>					<i>Interrupt Polarity</i>	<i>Reserved</i>	<i>Interrupt Mode</i>

Optical Sensor LTR-659PS-01

Field	Bits	Default	Type	Description	
Reserved	7:3	00000	--	--	
Interrupt Polarity	2	0	RW	0	INT pin is considered active when it is a logic 0 (default)
				1	INT pin is considered active when it is a logic 1
Reserved	1	0	--	--	
Interrupt mode	1:0	00	RW	0	Interrupt pin is INACTIVE/high impedance state (default)
				1	PS measurement can trigger interrupt

PS_THRES Register (0x90 / 0x91 / 0x92 / 0x93)

The PS_THRES_UP and PS_THRES_LOW registers determines the upper and lower limit of the interrupt threshold value respectively. These two values form a range and the interrupt function compares if the measurement value in PS_DATA registers is inside or outside the range. The interrupt function is active if the measurement data is outside the range defined by the upper and lower limits. The data format for PS_THRES must be the same as PS_DATA registers.

0x90	PS_THRES_UP_0 (default = 0xFF)							
	B7	B6	B5	B4	B3	B2	B1	B0
	<i>PS Upper Threshold Low</i>							
0x91	PS_THRES_UP_1 (default = 0x07)							
	B7	B6	B5	B4	B3	B2	B1	B0
	<i>Reserved</i>				<i>PS Upper Threshold High</i>			

0x92	PS_THRES_LOW_0 (default = 0x00)							
	B7	B6	B5	B4	B3	B2	B1	B0
	<i>PS Lower Threshold Low</i>							
0x93	PS_THRES_LOW_1 (default = 0x00)							
	B7	B6	B5	B4	B3	B2	B1	B0
	<i>Reserved</i>				<i>PS Lower Threshold High</i>			

Optical Sensor LTR-659PS-01

Field	Address	Bits	Default	Type	Description
PS Upper Threshold Low	0x90	7:0	11111111	RW	PS upper threshold lower byte
Reserved	0x91	7:3	00000	--	Reserved
PS Upper Threshold High	0x91	2:0	111	RW	PS upper threshold upper byte
PS lower threshold, Low	0x92	7:0	00000000	RW	PS lower interrupt threshold value, lower byte
Reserved	0x93	7:3	00000	--	Reserved
PS lower threshold, High	0x93	2:0	000	RW	PS lower interrupt threshold value, upper byte

PS_OFFSET Register (0x94 / 0x95)

The PS_OFFSET register defines the offset compensation value for proximity offsets caused by device variations, optical crosstalk and other environment factors. This value will be used and cancelled from the original PS raw data such that the data in PS_DATA register (0x8D and 0x8E) are the compensated value.

0x94	PS_OFFSET_1 (default = 0x00)							
	B7	B6	B5	B4	B3	B2	B1	B0
	<i>Reserved</i>						<i>PS Offset, High byte</i>	

0x95	PS_OFFSET_0 (default = 0x00)							
	B7	B6	B5	B4	B3	B2	B1	B0
	<i>PS Offset, Low byte</i>							

Optical Sensor LTR-659PS-01

INTERRUPT PERSIST Register (0x9E)

The INTERRUPT PERSIST register controls the N number of times the measurement data is outside the range defined by the upper and lower threshold limits before asserting the interrupt.

0x9E	INTERRUPT PERSIST (default = 0x00)							
	B7	B6	B5	B4	B3	B2	B1	B0
	<i>PS Persist</i>				<i>Reserved</i>			

Field	Bits	Default	Type	Description	
PS persist	7:4	0000	RW	0000	Every PS value out of threshold range (default)
				0001	2 consecutive PS values out of threshold range
			
				1111	16 consecutive PS values out of threshold range
Reserved	3:0	0000	--	--	--

10. Device Operation(using Interrupt)

Below flow diagram illustrates the LTR-659PS operation involving the use of Thresholds and Interrupts.

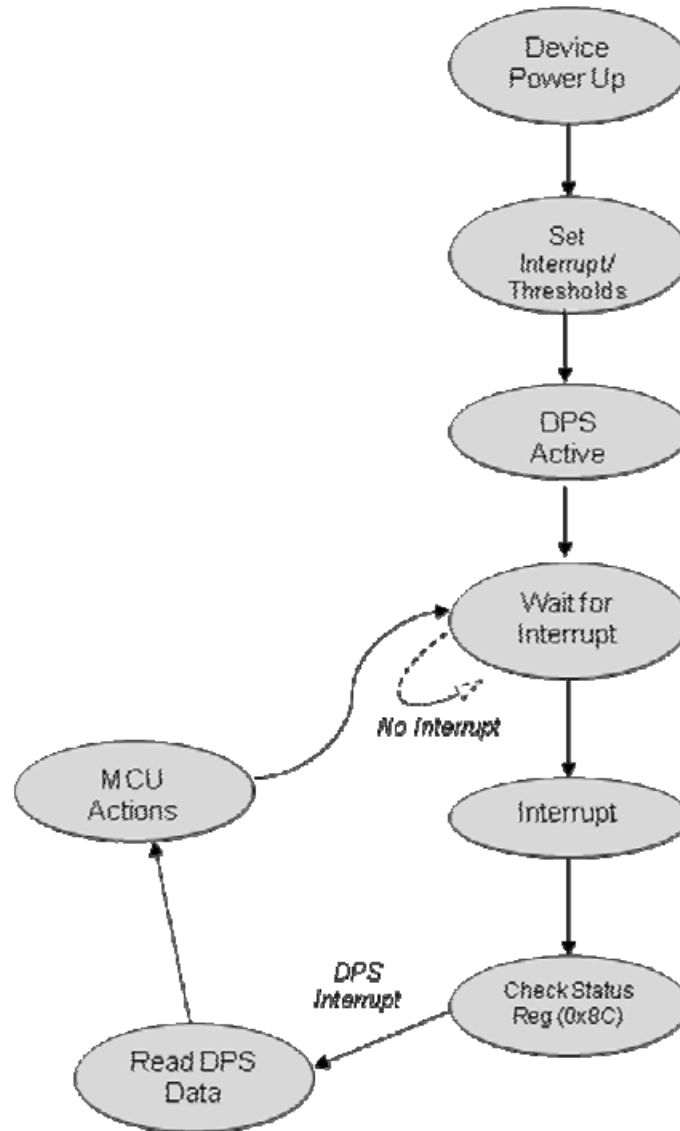

Optical Sensor LTR-659PS-01

11. Pseudo Codes Examples

Control Registers

// The Control Registers define the operating modes and gain settings of PS of LTR-659.
 // Default settings are 0x00 for both registers (both in Standby mode).

Slave_Addr = 0x23 // Slave address of LTR-659 device

// Enable PS

Register_Addr = 0x81 // PS_CONTR register
 Command = 0x03 // Gain = 16
 // For Gain = 32, Command = 0x0B
 // For Gain = 64, Command = 0x0F

WriteByte(Slave_Addr, Register_Addr, Command)

PS LED Registers

// The PS LED Registers define the LED pulse modulation frequency, duty cycle and peak current.
 // Default setting is 0x7F (60kHz, 100%, 100mA).

Slave_Addr = 0x23 // Slave address of LTR-659 device

// Set LED Pulse Freq 30kHz (duty cycle 100%, peak curr 100mA)

Register_Addr = 0x82 // PS_LED register
 Command = 0x1F // Pulse Freq = 30kHz, (duty cyc 100%, peak curr 100mA)
 // For Pulse Freq = 40kHz, (100%, 100mA), Command = 0x3F
 // For Pulse Freq = 50kHz, (100%, 100mA), Command = 0x5F
 // For Pulse Freq = 60kHz, (100%, 100mA), Command = 0x7F
 // For Pulse Freq = 70kHz, (100%, 100mA), Command = 0x9F
 // For Pulse Freq = 80kHz, (100%, 100mA), Command = 0xBF
 // For Pulse Freq = 90kHz, (100%, 100mA), Command = 0xDF
 // For Pulse Freq = 100kHz, (100%, 100mA), Command = 0xFF

WriteByte(Slave_Addr, Register_Addr, Command)

// Set LED Duty Cycle 25% (pulse freq 60kHz, peak curr 100mA)

Register_Addr = 0x82 // PS_LED register
 Command = 0x67 // Duty Cycle = 25%, (pulse freq 60kHz, peak curr 100mA)
 // For Duty Cycle = 50%, (60kHz, 100mA), Command = 0x6F
 // For Duty Cycle = 75%, (60kHz, 100mA), Command = 0x77
 // For Duty Cycle = 100%, (60kHz, 100mA), Command = 0x7F

WriteByte(Slave_Addr, Register_Addr, Command)

// Set LED Peak Current 5mA (pulse freq 60kHz, duty cycle 100%)

Register_Addr = 0x82 // PS_LED register
 Command = 0x78 // Peak Current = 5mA, (pulse freq 60kHz, duty cyc 100%)
 // For Peak Current = 10mA, (60kHz, 100%), Command = 0x79
 // For Peak Current = 20mA, (60kHz, 100%), Command = 0x7A
 // For Peak Current = 50mA, (60kHz, 100%), Command = 0x7B

WriteByte(Slave_Addr, Register_Addr, Command)

PS Measurement Rate Register

// The PS_MEAS_RATE register controls the PS measurement rate.

Optical Sensor LTR-659PS-01

// Default setting of the register is 0x02 (repeat rate 100ms)

Slave_Addr = 0x23 // Slave address of LTR-659 device

// Set PS Repeat Rate 50ms

Register_Addr = 0x84

// PS_MEAS_RATE register

Command = 0x00

// Meas rate = 50ms

// For Meas rate = 500ms, Command = 0x04

WriteByte(Slave_Addr, Register_Addr, Command)

PS Status Register (Read Only)

// The PS_STATUS Register contains the information on Interrupt, PS data availability status.

// This register is read only.

Slave_Addr = 0x23 // Slave address of LTR-659 device

// Read back Register

Register_Addr = 0x8C

// PS_STATUS register address

ReadByte(Slave_Addr, Register_Addr, Data)

Interrupt_Status = Data & 0x02

// Interrupt_Status = 2(decimal) → PS Interrupt

NewData_Status = Data & 0x01

// NewData_Status = 1(decimal) → PS New Data

PS Data Registers (Read Only)

// The PS Data Registers contain the ADC output data.

// These registers should be read as a group, with the lower address being read first.

Slave_Addr = 0x23 // Slave address of LTR-659 device

// Read back PS_DATA registers

Register_Addr = 0x8D

// PS_DATA low byte address

ReadByte(Slave_Addr, Register_Addr, Data0)

Register_Addr = 0x8E

// PS_DATA high byte address

ReadByte(Slave_Addr, Register_Addr, Data1)

PS_ADC_Data = (Data1 << 8) | Data0

// Combining lower and upper bytes to give 16-bit PS data

Interrupt Registers

// The Interrupt register controls the operation of the interrupt pins and function.

// The default value for this register is 0x08 (Interrupt inactive)

Slave_Addr = 0x23 // Slave address of LTR-659 device

// Set Interrupt Polarity for Active Low, for PS trigger

Register_Addr = 0x8F

// Interrupt Register address

Command = 0x03

// Interrupt is Active Low, PS can trigger

// For Active High Interrupt, Command = 0x05

WriteByte(Slave_Addr, Register_Addr, Command)

Optical Sensor LTR-659PS-01

PS Threshold Registers

// The PS_THRES_UP and PS_THRES_LOW registers determines the upper and
// lower limit of the interrupt threshold value.
// Following example illustrates the setting of the PS threshold window of
// decimal values of 200 (lower threshold) and 1000 (upper threshold)

Slave_Addr = 0x23 // Slave address of LTR-659 device

// Upper Threshold Setting (decimal 1000)

PS_Upp_Threshold_Reg_0 = 0x90 // PS Upper Threshold Low Byte Register address
PS_Upp_Threshold_Reg_1 = 0x91 // PS Upper Threshold High Byte Register address
Data1 = 1000 >> 8 // To convert decimal 1000 into two eight bytes register values
Data0 = 1000 & 0xFF
WriteByte(Slave_Addr, PS_Upp_Threshold_Reg_0, Data0)
WriteByte(Slave_Addr, PS_Upp_Threshold_Reg_1, Data1)

// Lower Threshold Setting (decimal 200)

PS_Low_Threshold_Reg_0 = 0x92 // PS Lower Threshold Low Byte Register address
PS_Low_Threshold_Reg_1 = 0x93 // PS Lower Threshold High Byte Register address
Data1 = 200 >> 8 // To convert decimal 200 into two eight bytes register values
Data0 = 200 & 0xFF
WriteByte(Slave_Addr, PS_Low_Threshold_Reg_0, Data0)
WriteByte(Slave_Addr, PS_Low_Threshold_Reg_1, Data1)

**Optical Sensor
LTR-659PS-01**

12. Recommended Leadfree Reflow Profile

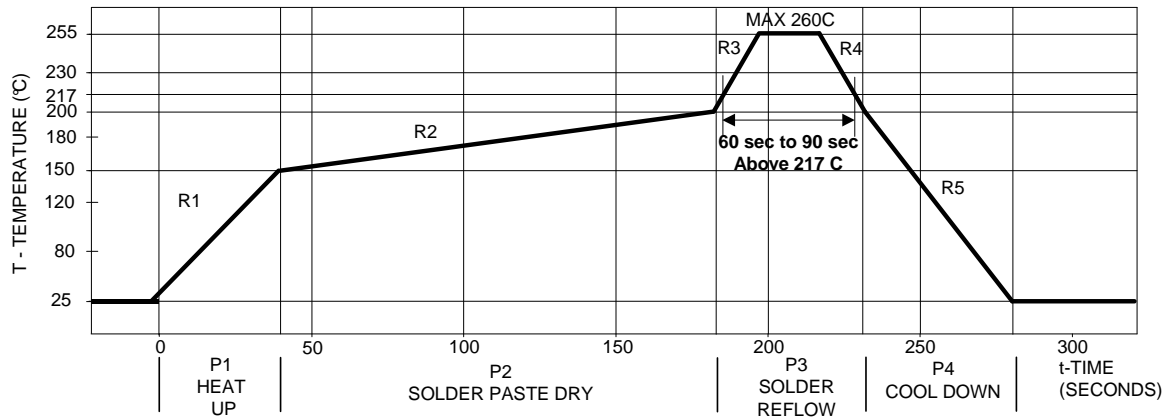

Process Zone	Symbol	ΔT	Maximum $\Delta T/\Delta \text{time}$ or Duration
Heat Up	P1, R1	25°C to 150°C	3°C/s
Solder Paste Dry	P2, R2	150°C to 200°C	100s to 180s
Solder Reflow	P3, R3	200°C to 260°C	3°C/s
	P3, R4	260°C to 200°C	-6°C/s
Cool Down	P4, R5	200°C to 25°C	-6°C/s
Time maintained above liquidus point, 217°C		> 217°C	60s to 90s
Peak Temperature		260°C	-
Time within 5°C of actual Peak Temperature		> 255°C	20s
Time 25°C to Peak Temperature		25°C to 260°C	8mins

It is recommended to perform reflow soldering no more than twice.

**Optical Sensor
LTR-659PS-01**

13. Moisture Proof Packaging

All LTR-659PS-01 are shipped in moisture proof package. Once opened, moisture absorption begins. This part is compliant to JEDEC J-STD-033A Level 3.

Time from Unsealing to Soldering

After removal from the moisture barrier bag, the parts should be stored at the recommended storage conditions and soldered within seven days. When the moisture barrier bag is opened and the parts are exposed to the recommended storage conditions for more than seven days, the parts must be baked before reflow to prevent damage to the parts.

Recommended Storage Conditions

Storage Temperature	10°C to 30°C
Relative Humidity	Below 60% RH

Baking Conditions

Package	Temperature	Time
In Reels	60°C	48 hours
In Bulk	100°C	4 hours

Baking should only be done once.

14. Recommended Land Pattern and Metal Stencil Aperture

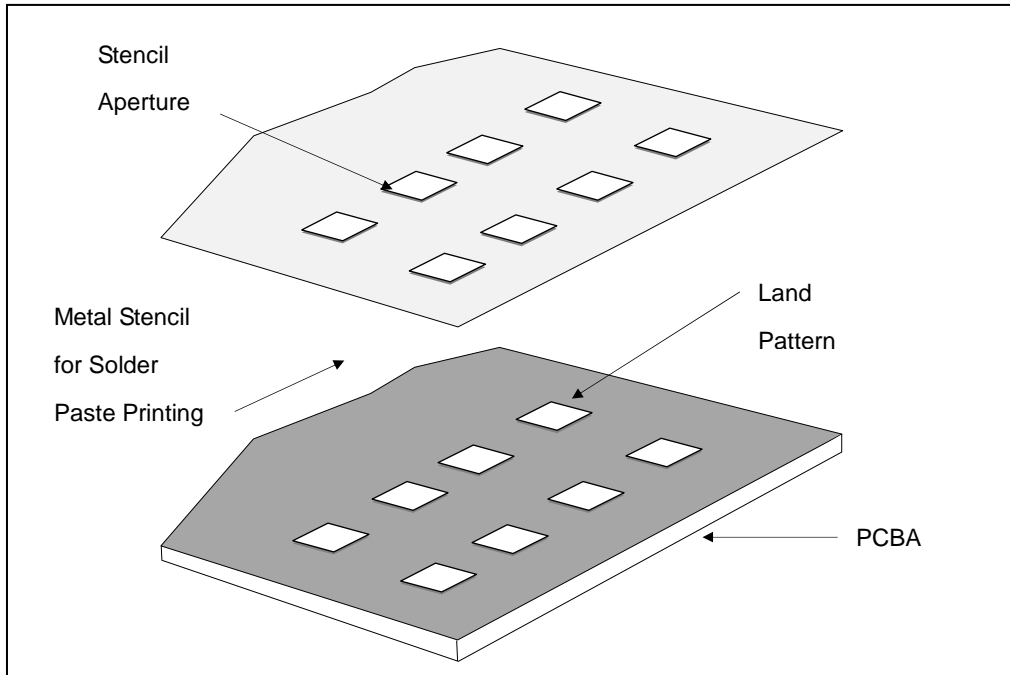

Recommended Land Pattern

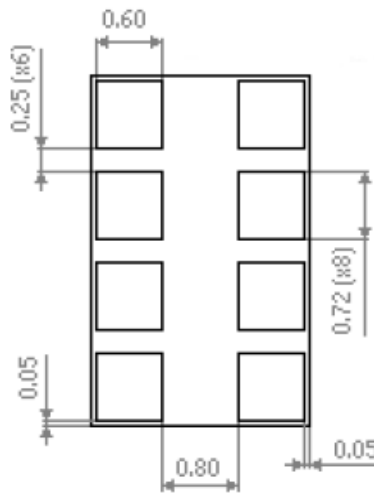

Note:

1. All dimensions are in millimeters

Optical Sensor LTR-659PS-01

Recommended Metal Stencil Aperture

It is recommended that the metal stencil used for solder paste printing has a thickness (t) of 0.11mm (0.004 inches / 4 mils) or 0.127mm (0.005 inches / 5 mils).

The stencil aperture opening is recommended to be 0.72mm x 0.60mm which has the same dimension as the land pattern. This is to ensure adequate printed solder paste volume and yet no shorting.

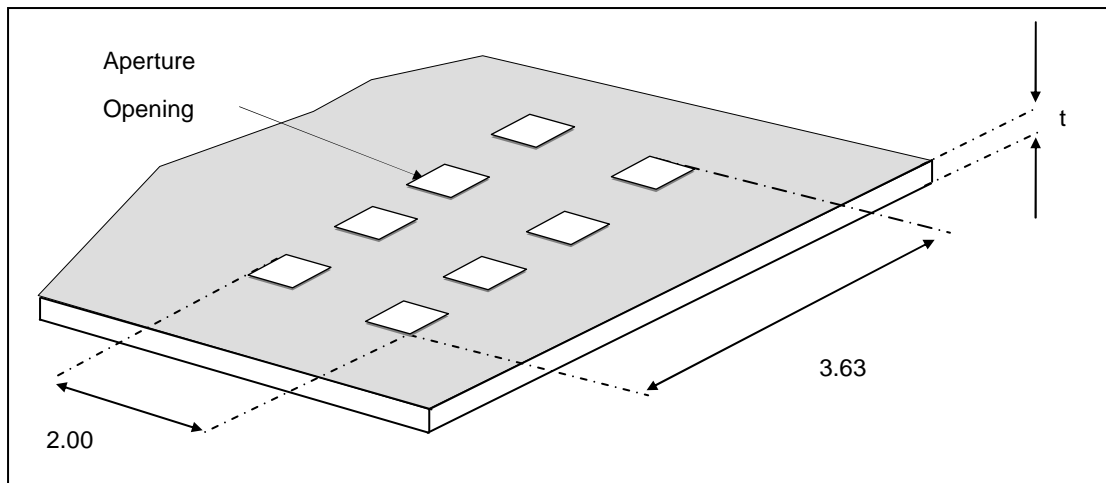

Note:

1. All dimensions are in millimeters

**Optical Sensor
LTR-659PS-01**

15. Package Dimension for Tape and Reel

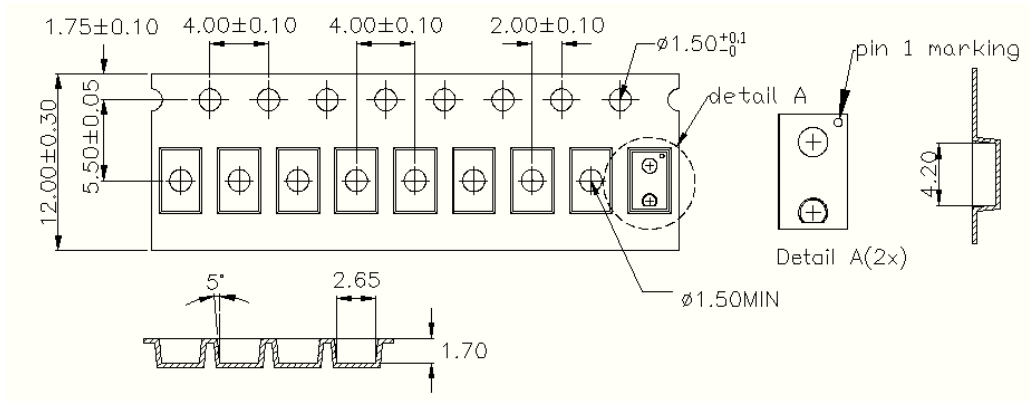

Note:

1. All dimensions are in millimeters

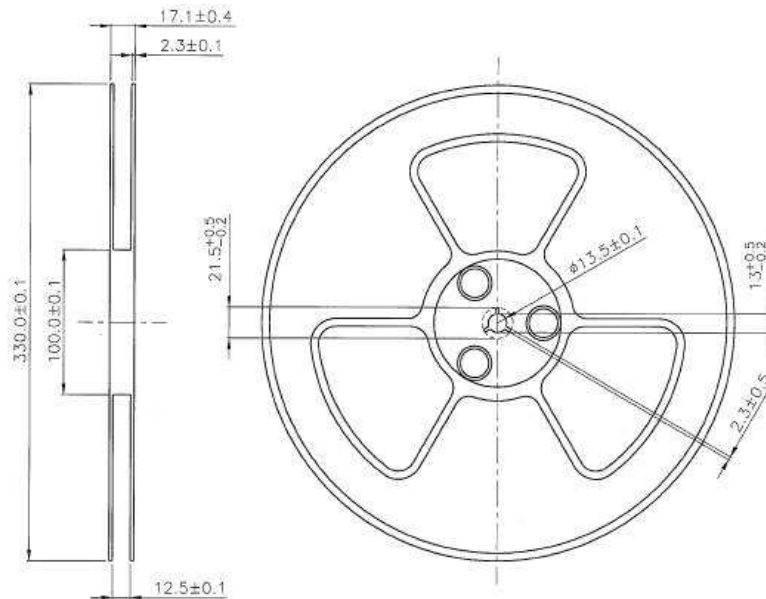

Notes:

1. All dimensions are in millimeters (inches)
2. Empty component pockets sealed with top cover tape
3. 13 inch reel - 8000 pieces per reel
4. In accordance with ANSI/EIA 481-1-A-1994 specifications.