

MC100EL30

5V ECL Triple D Flip-Flop with Set and Reset

The MC100EL30 is a triple master-slave D flip-flop with differential outputs. Data enters the master latch when the clock input is LOW and transfers to the slave upon a positive transition on the clock input.

In addition to a common Set input individual Reset inputs are provided for each flip flop. Both the Set and Reset inputs function asynchronous and overriding with respect to the clock inputs.

Features

- 1200 MHz Minimum Toggle Frequency
 - 450 ps Typical Propagation Delays
 - ESD Protection: >2 kV Human Body Model
 - The 100 Series Contains Temperature Compensation.
 - PECL Mode Operating Range:
 $V_{CC} = 4.2\text{ V to }5.7\text{ V}$ with $V_{EE} = 0\text{ V}$
 - NECL Mode Operating Range:
 $V_{CC} = 0\text{ V}$ with $V_{EE} = -4.2\text{ V to }-5.7\text{ V}$
 - Internal Input 75 k Ω Pulldown Resistors
 - Meets or Exceeds JEDEC Spec EIA/JESD78 IC Latchup Test
 - Moisture Sensitivity: Pb = Level 1
Pb-Free = Level 3
- For Additional Information, see Application Note AND8003/D
- Flammability Rating: UL 94 V-0 @ 0.125 in, Oxygen Index: 28 to 34
 - Transistor Count = 347 devices
 - Pb-Free Packages are Available*



ON Semiconductor®

<http://onsemi.com>

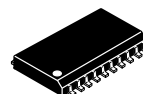

SO-20 WB
DW SUFFIX
CASE 751D

MARKING DIAGRAM*

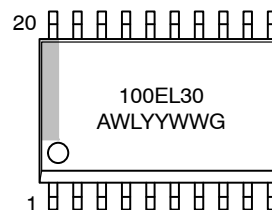

A = Assembly Location
WL = Wafer Lot
YY = Year
WW = Work Week
G = Pb-Free Package

*For additional marking information, refer to Application Note AND8002/D.

ORDERING INFORMATION

See detailed ordering and shipping information in the package dimensions section on page 5 of this data sheet.

*For additional information on our Pb-Free strategy and soldering details, please download the ON Semiconductor Soldering and Mounting Techniques Reference Manual, SOLDERRM/D.

MC100EL30

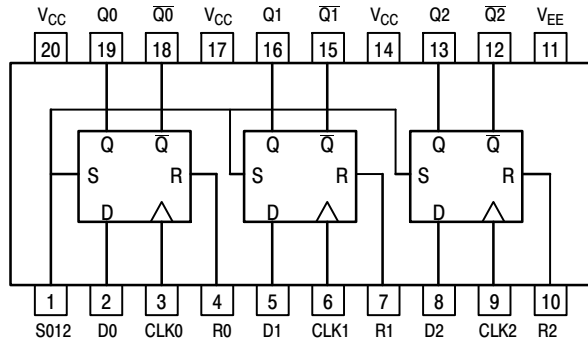

Warning: All V_{CC} and V_{EE} pins must be externally connected to Power Supply to guarantee proper operation.

Figure 1. Logic Diagram and Pinout: 20-Lead SOIC (Top View)

Table 1. PIN DESCRIPTION

| Pin | Function |
|---------------------------|-------------------------------|
| D0–D2 | ECL Data Inputs |
| R0–R2 | ECL Reset Inputs |
| CLK0–CLK2 | ECL Clock Inputs |
| S012 | ECL Common Set Input |
| Q0–Q2; $\overline{Q0-Q2}$ | ECL Differential Data Outputs |
| V _{CC} | Positive Supply |
| V _{EE} | Negative Supply |

Table 2. FUNCTION TABLE

| R* | S* | D* | CLK* | Q | \overline{Q} |
|----|----|----|------|-------|----------------|
| L | L | L | Z | L | H |
| L | L | H | Z | H | L |
| H | L | X | X | L | H |
| L | H | X | X | H | L |
| H | H | X | X | Undef | Undef |

Z = Low-to-High Transition

X = Don't Care

*Pin will default low when left open.

Table 3. MAXIMUM RATINGS

| Symbol | Parameter | Condition 1 | Condition 2 | Rating | Unit |
|------------------|--|--|--|-------------------|--------------|
| V _{CC} | PECL Mode Power Supply | V _{EE} = 0 V | | 8 to 0 | V |
| V _{EE} | NECL Mode Power Supply | V _{CC} = 0 V | | -8 to 0 | V |
| V _I | PECL Mode Input Voltage NECL Mode Input Voltage | V _{EE} = 0 V V _{CC} = 0 V | V _I ≤ V _{CC} V _I ≥ V _{EE} | 6 to 0 -6 to 0 | V V |
| I _{out} | Output Current | Continuous Surge | | 50 100 | mA mA |
| T _A | Operating Temperature Range | | | -40 to +85 | °C |
| T _{stg} | Storage Temperature Range | | | -65 to +150 | °C |
| θ _{JA} | Thermal Resistance (Junction-to-Ambient) | 0 lfpm 500 lfpm | SOIC-20 SOIC-20 | 90 60 | °C/W °C/W |
| θ _{JC} | Thermal Resistance (Junction-to-Case) | Standard Board | SOIC-20 | 30 to 35 | °C/W |
| T _{sol} | Wave Solder | Pb Pb-Free | <2 to 3 sec @ 248°C <2 to 3 sec @ 260°C | 265 265 | °C |

Stresses exceeding Maximum Ratings may damage the device. Maximum Ratings are stress ratings only. Functional operation above the Recommended Operating Conditions is not implied. Extended exposure to stresses above the Recommended Operating Conditions may affect device reliability.

MC100EL30

Table 4. PECL DC CHARACTERISTICS $V_{CC}= 5.0\text{ V}$; $V_{EE}= 0.0\text{ V}$ (Note 1)

| Symbol | Characteristic | -40°C | | | 25°C | | | 85°C | | | Unit |
|----------|------------------------------|-------|------|------|------|------|------|------|------|------|---------------|
| | | Min | Typ | Max | Min | Typ | Max | Min | Typ | Max | |
| I_{EE} | Power Supply Current | | 55 | 62 | | 55 | 62 | | 55 | 64 | mA |
| V_{OH} | Output HIGH Voltage (Note 2) | 3915 | 3995 | 4120 | 3975 | 4045 | 4120 | 3975 | 4050 | 4120 | mV |
| V_{OL} | Output LOW Voltage (Note 2) | 3170 | 3305 | 3445 | 3190 | 3295 | 3380 | 3190 | 3295 | 3380 | mV |
| V_{IH} | Input HIGH Voltage | 3835 | | 4120 | 3835 | | 4120 | 3835 | | 4120 | mV |
| V_{IL} | Input LOW Voltage | 3190 | | 3525 | 3190 | | 3525 | 3190 | | 3525 | mV |
| I_{IH} | Input HIGH Current | | | 150 | | | 150 | | | 150 | μA |
| I_{IL} | Input LOW Current | 0.5 | | | 0.5 | | | 0.5 | | | μA |

NOTE: Device will meet the specifications after thermal equilibrium has been established when mounted in a test socket or printed circuit board with maintained transverse airflow greater than 500 lfm. Electrical parameters are guaranteed only over the declared operating temperature range. Functional operation of the device exceeding these conditions is not implied. Device specification limit values are applied individually under normal operating conditions and not valid simultaneously.

1. Input and output parameters vary 1:1 with V_{CC} . V_{EE} can vary +0.8 V / -0.5 V.
2. Outputs are terminated through a 50 Ω resistor to $V_{CC} - 2.0\text{ V}$.

Table 5. NECL DC CHARACTERISTICS $V_{CC}= 0.0\text{ V}$; $V_{EE}= -5.0\text{ V}$ (Note 3)

| Symbol | Characteristic | -40°C | | | 25°C | | | 85°C | | | Unit |
|----------|------------------------------|-------|-------|-------|-------|-------|-------|-------|-------|-------|---------------|
| | | Min | Typ | Max | Min | Typ | Max | Min | Typ | Max | |
| I_{EE} | Power Supply Current | | 55 | 62 | | 55 | 62 | | 55 | 64 | mA |
| V_{OH} | Output HIGH Voltage (Note 4) | -1085 | -1005 | -880 | -1025 | -955 | -880 | -1025 | -955 | -880 | mV |
| V_{OL} | Output LOW Voltage (Note 4) | -1830 | -1695 | -1555 | -1810 | -1705 | -1620 | -1810 | -1705 | -1620 | mV |
| V_{IH} | Input HIGH Voltage | -1165 | | -880 | -1165 | | -880 | -1165 | | -880 | mV |
| V_{IL} | Input LOW Voltage | -1810 | | -1475 | -1810 | | -1475 | -1810 | | -1475 | mV |
| I_{IH} | Input HIGH Current | | | 150 | | | 150 | | | 150 | μA |
| I_{IL} | Input LOW Current | 0.5 | | | 0.5 | | | 0.5 | | | μA |

NOTE: Device will meet the specifications after thermal equilibrium has been established when mounted in a test socket or printed circuit board with maintained transverse airflow greater than 500 lfm. Electrical parameters are guaranteed only over the declared operating temperature range. Functional operation of the device exceeding these conditions is not implied. Device specification limit values are applied individually under normal operating conditions and not valid simultaneously.

3. Input and output parameters vary 1:1 with V_{CC} . V_{EE} can vary +0.8 V / -0.5 V.
4. Outputs are terminated through a 50 Ω resistor to $V_{CC} - 2.0\text{ V}$.

MC100EL30

Table 6. AC CHARACTERISTICS $V_{CC}= 5.0\text{ V}; V_{EE}= 0.0\text{ V}$ or $V_{CC}= 0.0\text{ V}; V_{EE}= -5.0\text{ V}$ (Note 5)

| Symbol | Characteristic | -40°C | | | 25°C | | | 85°C | | | Unit |
|------------------------|--|------------|----------|-----|------------|----------|-----|------------|----------|-----|------|
| | | Min | Typ | Max | Min | Typ | Max | Min | Typ | Max | |
| f_{\max} | Maximum Toggle Frequency | 1.0 | | | 1.2 | | | 1.2 | | | GHz |
| t_{PLH} t_{PHL} | Propagation Delay to Output CLK, S, R | 550 | | 800 | 570 | | 820 | 590 | | 840 | ps |
| t_S t_H | Setup Time Hold Time | 150 200 | 0 100 | | 150 200 | 0 100 | | 150 200 | 0 100 | | ps |
| t_{RR} | Set/Reset Recovery | 400 | 200 | | 400 | 200 | | 400 | 200 | | ps |
| t_{PW} | Minimum Pulse Width CLK Set, Reset | 400 650 | | | 400 650 | | | 400 650 | | | ps |
| t_{JITTER} | Cycle-to-Cycle Jitter | | TBD | | | TBD | | | TBD | | ps |
| t_r t_f | Output Rise/Fall Times Q (20% – 80%) | 280 | | 550 | 280 | 450 | 550 | 280 | | 550 | ps |

NOTE: Device will meet the specifications after thermal equilibrium has been established when mounted in a test socket or printed circuit board with maintained transverse airflow greater than 500 lfm. Electrical parameters are guaranteed only over the declared operating temperature range. Functional operation of the device exceeding these conditions is not implied. Device specification limit values are applied individually under normal operating conditions and not valid simultaneously.

5. V_{EE} can vary +0.8 V / -0.5 V.

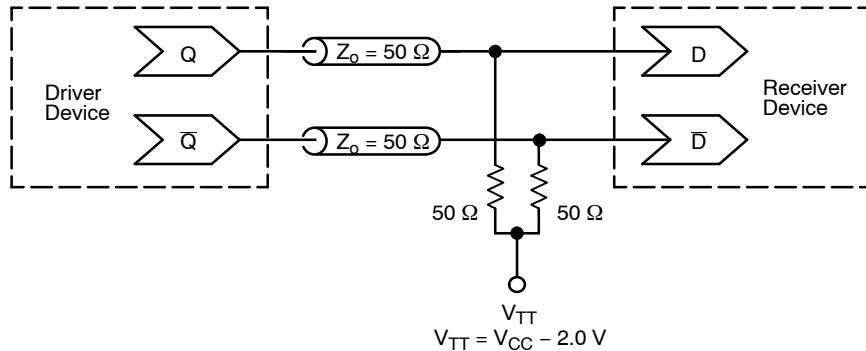

Figure 2. Typical Termination for Output Driver and Device Evaluation
(See Application Note AND8020/D – Termination of ECL Logic Devices.)

MC100EL30

ORDERING INFORMATION

| Device | Package | Package [†] |
|----------------|----------------------|----------------------|
| MC100EL30DW | SOIC-20 | 38 Units / Rail |
| MC100EL30DWG | SOIC-20 (Pb-Free) | 38 Units / Rail |
| MC100EL30DWR2 | SOIC-20 | 1000 / Tape & Reel |
| MC100EL30DWR2G | SOIC-20 (Pb-Free) | 1000 / Tape & Reel |

[†]For information on tape and reel specifications, including part orientation and tape sizes, please refer to our Tape and Reel Packaging Specifications Brochure, BRD8011/D.

Resource Reference of Application Notes

- AN1405/D** - ECL Clock Distribution Techniques
- AN1406/D** - Designing with PECL (ECL at +5.0 V)
- AN1503/D** - ECLinPS I/O SPICE Modeling Kit
- AN1504/D** - Metastability and the ECLinPS Family
- AN1568/D** - Interfacing Between LVDS and ECL
- AN1672/D** - The ECL Translator Guide
- AND8001/D** - Odd Number Counters Design
- AND8002/D** - Marking and Date Codes
- AND8020/D** - Termination of ECL Logic Devices
- AND8066/D** - Interfacing with ECLinPS
- AND8090/D** - AC Characteristics of ECL Devices

MC100EL30

PACKAGE DIMENSIONS

SO-20 WB
DW SUFFIX
CASE 751D-05
ISSUE G

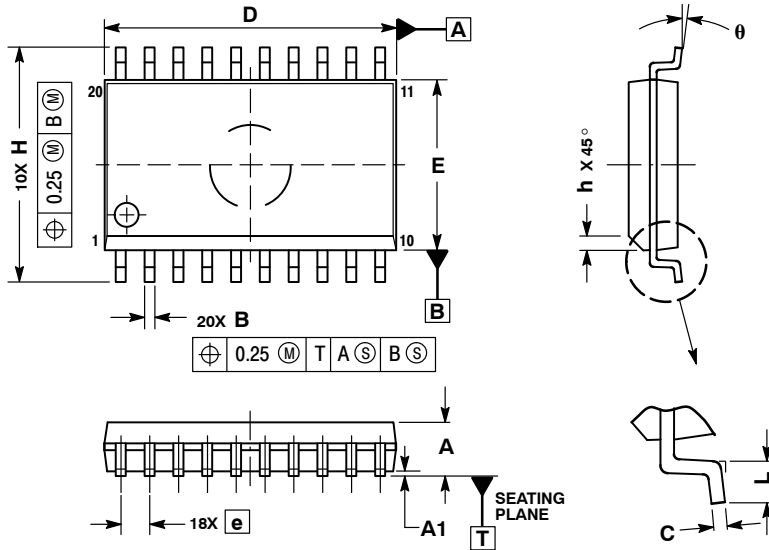

NOTES:

1. DIMENSIONS ARE IN MILLIMETERS.
2. INTERPRET DIMENSIONS AND TOLERANCES PER ASME Y14.5M, 1994.
3. DIMENSIONS D AND E DO NOT INCLUDE MOLD PROTRUSION.
4. MAXIMUM MOLD PROTRUSION 0.15 PER SIDE.
5. DIMENSION B DOES NOT INCLUDE DAMBAR PROTRUSION. ALLOWABLE PROTRUSION SHALL BE 0.13 TOTAL IN EXCESS OF B DIMENSION AT MAXIMUM MATERIAL CONDITION.

| DIM | MILLIMETERS | |
|-----|-------------|-------|
| | MIN | MAX |
| A | 2.35 | 2.65 |
| A1 | 0.10 | 0.25 |
| B | 0.35 | 0.49 |
| C | 0.23 | 0.32 |
| D | 12.65 | 12.95 |
| E | 7.40 | 7.60 |
| e | 1.27 BSC | |
| H | 10.05 | 10.55 |
| h | 0.25 | 0.75 |
| L | 0.50 | 0.90 |
| θ | 0° | 7° |

ECLinPS are registered trademarks of Semiconductor Components Industries, LLC (SCILLC).

ON Semiconductor and are registered trademarks of Semiconductor Components Industries, LLC (SCILLC). SCILLC reserves the right to make changes without further notice to any products herein. SCILLC makes no warranty, representation or guarantee regarding the suitability of its products for any particular purpose, nor does SCILLC assume any liability arising out of the application or use of any product or circuit, and specifically disclaims any and all liability, including without limitation special, consequential or incidental damages. "Typical" parameters which may be provided in SCILLC data sheets and/or specifications can and do vary in different applications and actual performance may vary over time. All operating parameters, including "Typicals" must be validated for each customer application by customer's technical experts. SCILLC does not convey any license under its patent rights nor the rights of others. SCILLC products are not designed, intended, or authorized for use as components in systems intended for surgical implant into the body, or other applications intended to support or sustain life, or for any other application in which the failure of the SCILLC product could create a situation where personal injury or death may occur. Should Buyer purchase or use SCILLC products for any such unintended or unauthorized application, Buyer shall indemnify and hold SCILLC and its officers, employees, subsidiaries, affiliates, and distributors harmless against all claims, costs, damages, and expenses, and reasonable attorney fees arising out of, directly or indirectly, any claim of personal injury or death associated with such unintended or unauthorized use, even if such claim alleges that SCILLC was negligent regarding the design or manufacture of the part. SCILLC is an Equal Opportunity/Affirmative Action Employer. This literature is subject to all applicable copyright laws and is not for resale in any manner.

PUBLICATION ORDERING INFORMATION

LITERATURE FULFILLMENT:
Literature Distribution Center for ON Semiconductor
P.O. Box 5163, Denver, Colorado 80217 USA
Phone: 303-675-2175 or 800-344-3860 Toll Free USA/Canada
Fax: 303-675-2176 or 800-344-3867 Toll Free USA/Canada
Email: orderlit@onsemi.com

N. American Technical Support: 800-282-9855 Toll Free
USA/Canada
Europe, Middle East and Africa Technical Support:
Phone: 421 33 790 2910
Japan Customer Focus Center
Phone: 81-3-5773-3850

ON Semiconductor Website: www.onsemi.com
Order Literature: <http://www.onsemi.com/orderlit>
For additional information, please contact your local Sales Representative

Mouser Electronics

Authorized Distributor

Click to View Pricing, Inventory, Delivery & Lifecycle Information:

[ON Semiconductor:](#)

[MC100EL30DWG](#) [MC100EL30DWR2G](#)