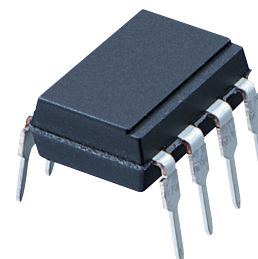


# PC912L0NSZ0F Series

High Speed 25Mb/s, High CMR type  
DIP 8 pin \*OPIC Photocoupler



## ■ Description

**PC912L0NSZ0F Series** contains a LED optically coupled to an OPIC chip.

It is packaged in a 8 pin DIP, available in SMT gullwing lead-form option.

Input-output isolation voltage(rms) is 5.0 kV. Data transfer rate is MAX. 25 Mb/s and CMR is MIN. 20 kV/μs.

## ■ Features

1. DIP 8 pin package
2. Double transfer mold package  
(Ideal for Flow Soldering)
3. High speed response  
( $t_{PHL}$  : MAX. 40ns,  $t_{PLH}$  : MAX. 40ns)
4. High noise immunity due to high instantaneous common mode rejection voltage  
( $CM_H$  : MIN. 20 kV/μs,  $CM_L$  : MIN. -20 kV/μs)
5. High isolation voltage between input and output  
( $V_{iso(rms)}$  : 5.0 kV)
6. Lead-free and RoHS directive compliant

## ■ Agency approvals/Compliance

1. Recognized by UL1577 (Double protection isolation), file No. E64380 (as model No. **PC912L**)
2. Approved by VDE (DIN EN60747-5-2<sup>(\*)</sup>) (as an option), file No. 40008898 (as model No. **PC912L**)
3. Package resin : UL flammability grade (94V-0)

<sup>(\*)</sup>DIN EN60747-5-2 : successor standard of DIN VDE0884

## ■ Applications

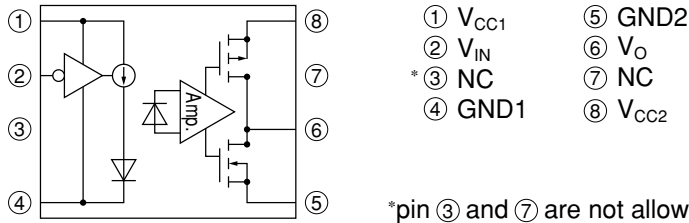
1. FA equipment

\* "OPIC"(Optical IC) is a trademark of the SHARP Corporation. An OPIC consists of a light-detecting element and a signal-processing circuit integrated onto a single chip.

Notice The content of data sheet is subject to change without prior notice.

In the absence of confirmation by device specification sheets, SHARP takes no responsibility for any defects that may occur in equipment using any SHARP devices shown in catalogs, data books, etc. Contact SHARP in order to obtain the latest device specification sheets before using any SHARP device.

## Internal Connection Diagram



\*pin ③ and ⑦ are not allowed external connection

## Truth table

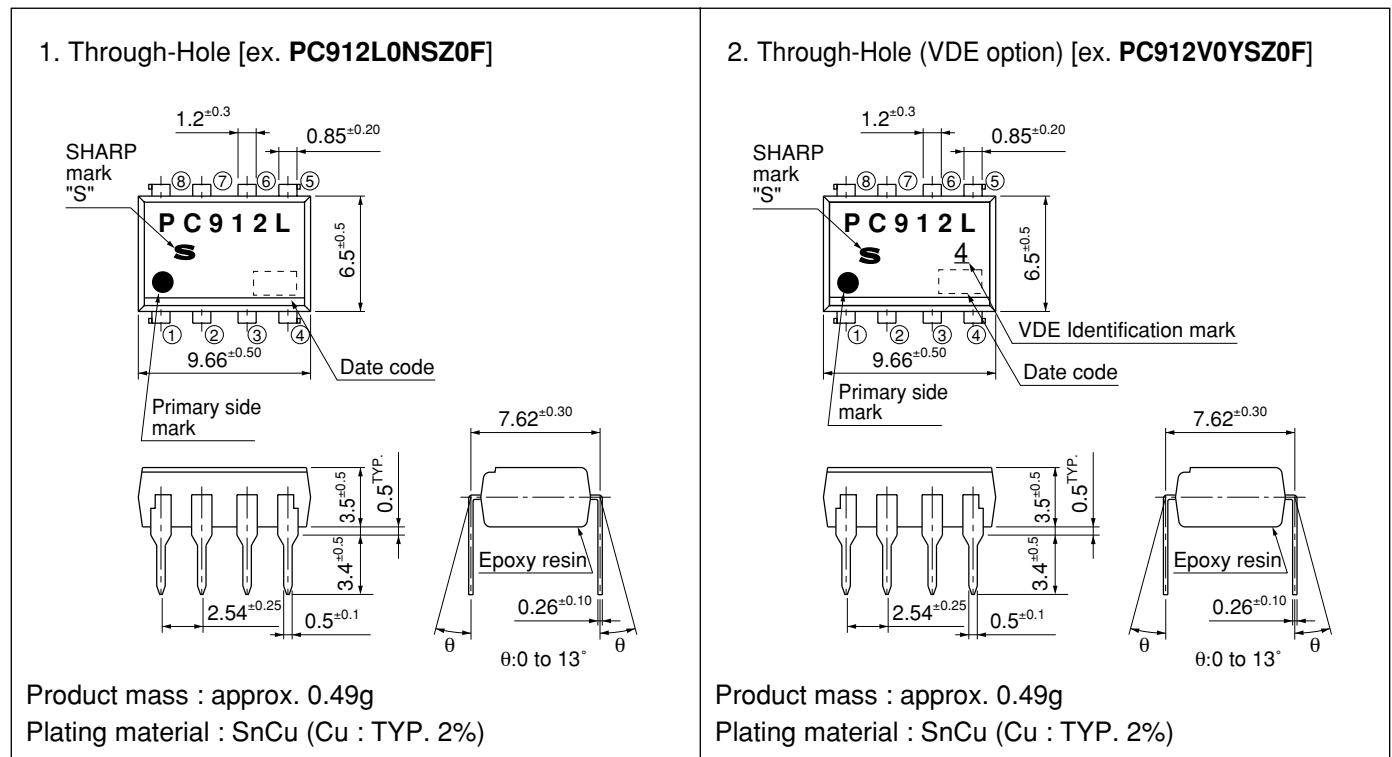
Input	LED	Output
L	ON	L
H	OFF	H

L : Logic (0)

H : Logic (1)

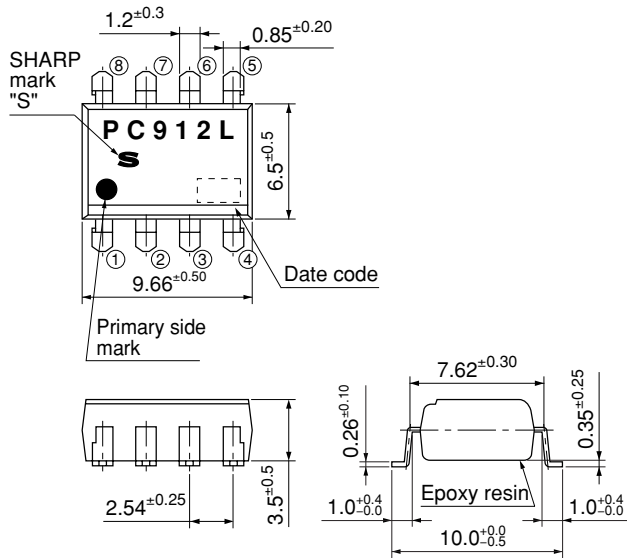
## Outline Dimensions

(Unit : mm)



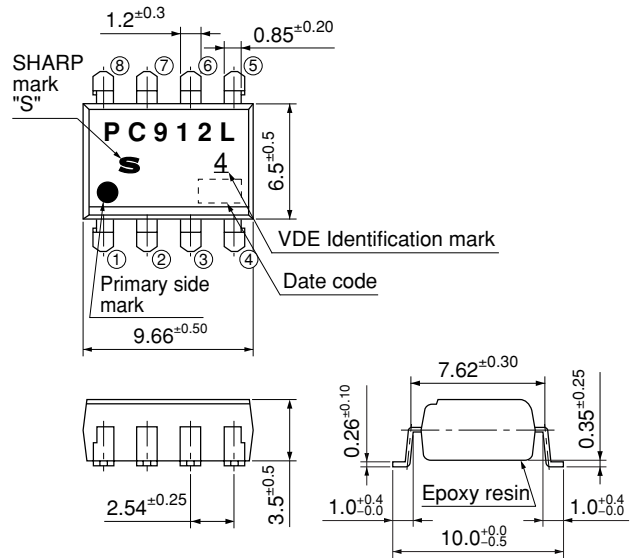
(Unit : mm)

**3. SMT Gullwing Lead-Form [ex. PC912L0NIZ0F]**



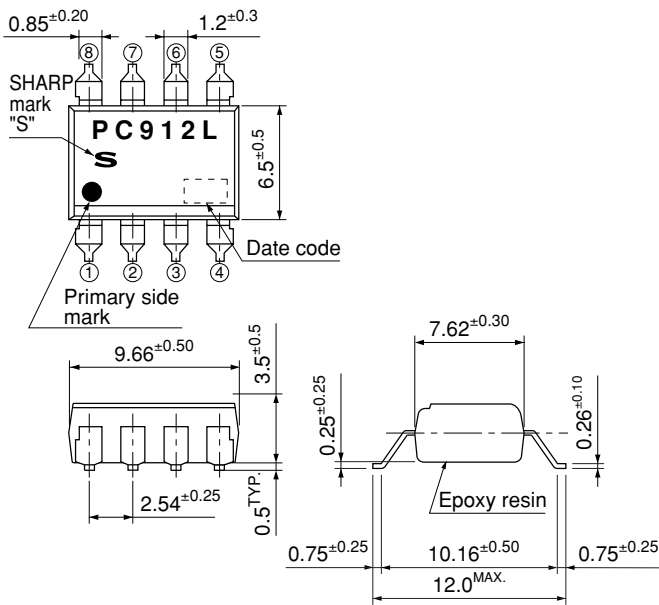
Product mass : approx. 0.49g  
 Plating material : SnCu (Cu : TYP. 2%)

**4. SMT Gullwing Lead-Form (VDE option) [ex. PC912L0YIZ0F]**



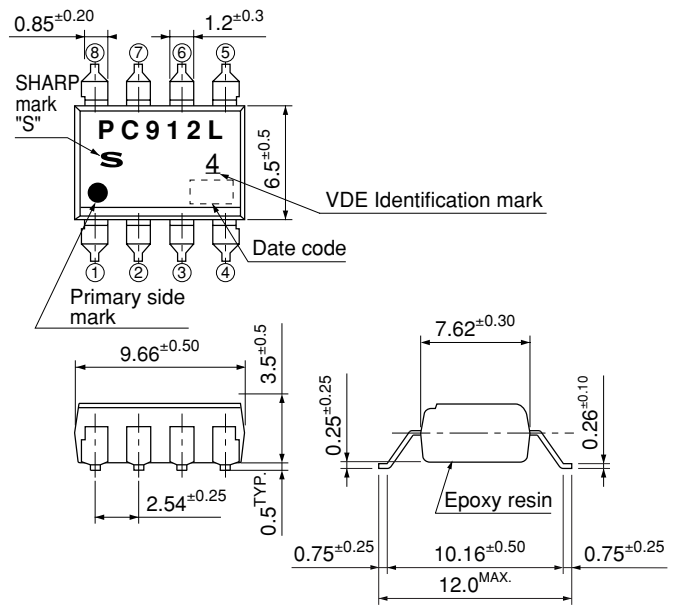
Product mass : approx. 0.49g  
 Plating material : SnCu (Cu : TYP. 2%)

**5. Wide SMT Gullwing Lead-Form [ex. PC912L0NUZ0F]**



Product mass : approx. 0.49g  
 Plating material : SnCu (Cu : TYP. 2%)

**6. Wide SMT Gullwing Lead-Form (VDE option) [ex. PC912L0YUZ0F]**



Product mass : approx. 0.49g  
 Plating material : SnCu (Cu : TYP. 2%)

Date code (2 digit)

1st digit				2nd digit	
Year of production				Month of production	
A.D.	Mark	A.D	Mark	Month	Mark
1990	A	2002	P	January	1
1991	B	2003	R	February	2
1992	C	2004	S	March	3
1993	D	2005	T	April	4
1994	E	2006	U	May	5
1995	F	2007	V	June	6
1996	H	2008	W	July	7
1997	J	2009	X	August	8
1998	K	2010	A	September	9
1999	L	2011	B	October	O
2000	M	2012	C	November	N
2001	N	∴	∴	December	D

repeats in a 20 year cycle

Country of origin

Japan

Rank mark

There is no rank mark indicator.

## Absolute Maximum Ratings

(Unless otherwise specified  $T_a=T_{opr}$ )

Parameter	Symbol	Rating	Unit	
Input	Supply voltage	$V_{CC1}$	0 to 5.5	V
	Input voltage	$V_{IN}$	-0.5 to $V_{CC1}+0.5$	V
Output	Supply voltage	$V_{CC2}$	0 to 5.5	V
	High level output voltage	$V_O$	-0.5 to $V_{CC2}+0.5$	V
	Low level output current	$I_O$	10	mA
*1 Isolation voltage	$V_{iso (rms)}$	5.0	kV	
Operating temperature	$T_{opr}$	-40 to +85	°C	
Storage temperature	$T_{stg}$	-55 to +125	°C	
*2 Soldering temperature	$T_{sol}$	270	°C	

\*1 40 to 60%RH, AC for 1minute,  $f=60\text{Hz}$

\*2 For 10s

## Electro-optical Characteristics\*3

(Unless otherwise specified  $T_a=T_{opr}$ )

Parameter		Symbol	Conditions	MIN.	TYP.	MAX.	Unit	
Input	Low level supply current	$I_{CC1L}$	$V_{IN}=0\text{V}$	-	6.0	10.0	mA	
	High level supply current	$I_{CC1H}$	$V_{IN}=V_{CC1}$	-	0.8	3.0	mA	
	Input current	$I_{IN}$	$V_{CC1}=5\text{V}$	-10	-	10	$\mu\text{A}$	
Output	High level supply current	$I_{CC2H}$	$V_{IN}=5\text{V}$	-	2.5	5.0	mA	
	Low level supply current	$I_{CC2L}$	$V_{IN}=0\text{V}$	-	2.0	4.0	mA	
	High level output voltage	$V_{OH}$	$I_O=-20\mu\text{A}, V_{IN}=5\text{V}$	4.4	5.0	-	V	
			$I_O=-4\text{mA}, V_{IN}=5\text{V}$	4.0	4.8	-	V	
	Low level output voltage	$V_{OL}$	$I_O=20\mu\text{A}, V_{IN}=0\text{V}$	-	0	0.1	V	
			$I_O=400\mu\text{A}, V_{IN}=0\text{V}$	-	-	0.1	V	
$I_O=4\text{mA}, V_{IN}=0\text{V}$			-	0.2	1.0	V		
Isolation resistance		$R_{ISO}$	DC500V, 40 to 60%RH	$5 \times 10^{10}$	$10^{11}$	-	$\Omega$	
Transfer characteristics	Response time	"High→Low" propagation delay time	$t_{PHL}$	$C_L=15\text{pF}$ , CMOS Logic level $V_{IN}=0 \rightarrow 5\text{V}$ $t_r=t_f < 1\text{ns}$ Pulse width 40ns Duty 50%	-	23	40	ns
		"Low→High" propagation delay time	$t_{PLH}$		-	22	40	ns
		Pulse width distortion $ t_{PHL}-t_{PLH} $	$\Delta t_w$		-	-	6	ns
		Propagation delay skew	$T_{PSK}$		-	-	20	ns
		Data transfer rate	$T$		-	-	25	Mb/s
		Rise time	$t_r$		-	4	-	ns
		Fall time	$t_f$		-	3	-	ns
	Instantaneous common mode rejection voltage "Output : High level"		$CM_H$	$V_{IN}=V_{CC1}, V_O < 0.8 \times V_{CC2}$ $V_{CM}=1\text{kV}$	20	-	-	kV/ $\mu\text{s}$
	Instantaneous common mode rejection voltage "Output : Low level"		$CM_L$	$V_{IN}=0, V_O < 0.8\text{V}$ $V_{CM}=1\text{kV}$	-20	-	-	kV/ $\mu\text{s}$

\*3 When measuring output and transfer characteristics, connect a by-pass capacitor (0.01 $\mu\text{F}$  or more) between  $V_{CC1}$  (pin ①) and  $GND_1$  (pin ④), between  $V_{CC2}$  (pin ⑧) and  $GND_2$  (pin ⑤) near the device.

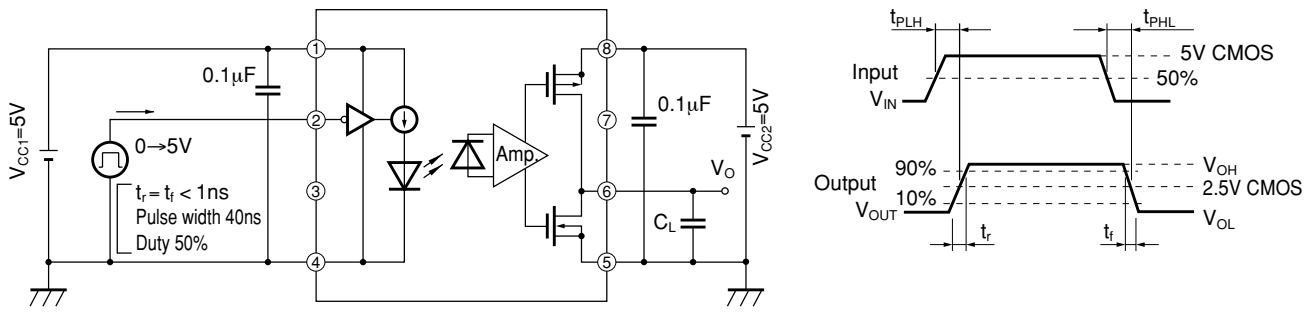
All typical values: at  $T_a=25^\circ\text{C}$ ,  $V_{CC1}=V_{CC2}=5\text{V}$

### ■ Model Line-up

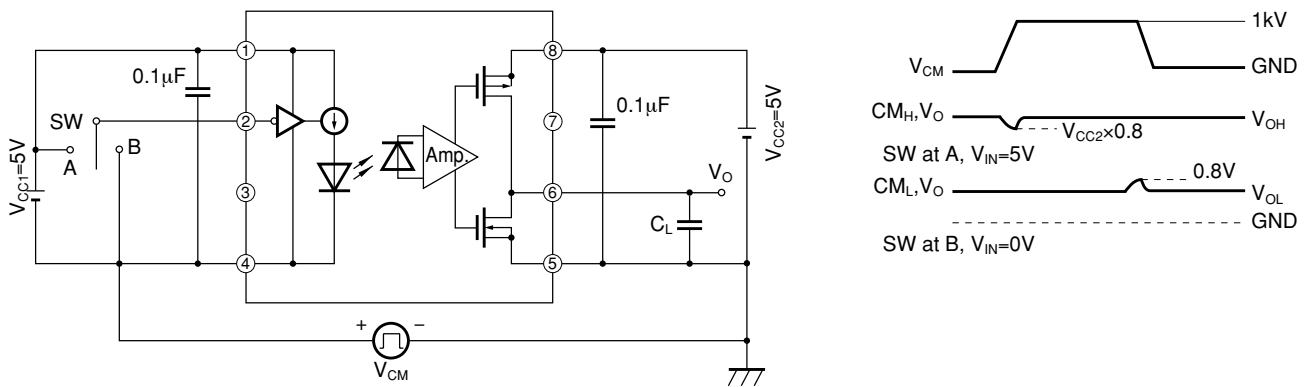
Lead Form	Through-Hole		SMT Gullwing		Wide SMT Gullwing	
Package	Sleeve		Sleeve		Sleeve	
	50pcs/sleeve		50pcs/sleeve		50pcs/sleeve	
DIN EN60747-5-2	———	Approved	———	Approved	———	Approved
Model No.	<b>PC912L0NSZ0F</b>	<b>PC912L0YSZ0F</b>	<b>PC912L0NIZ0F</b>	<b>PC912L0YIZ0F</b>	<b>PC912L0NUZ0F</b>	<b>PC912L0YUZ0F</b>

Please contact a local SHARP sales representative to inquire about production status.

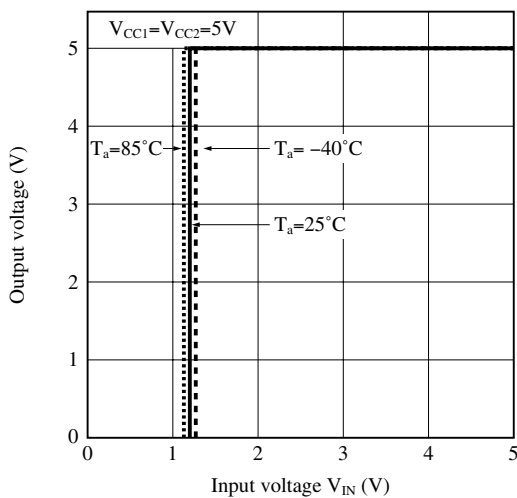
**Fig.1 Test Circuit for Propagation Delay Time and Rise Time, Fall Time**



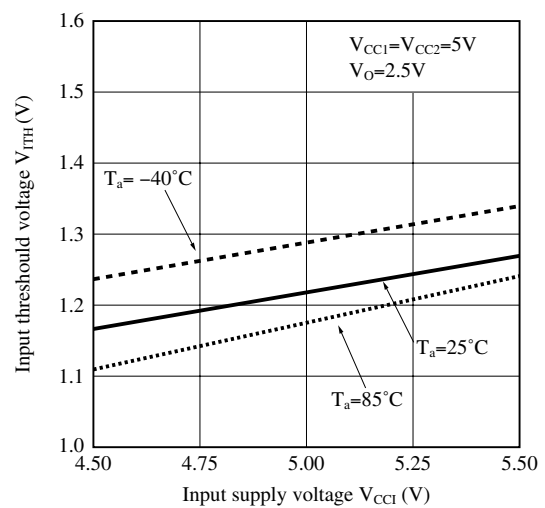
**Fig.2 Test Circuit for Instantaneous Common Mode Rejection Voltage**



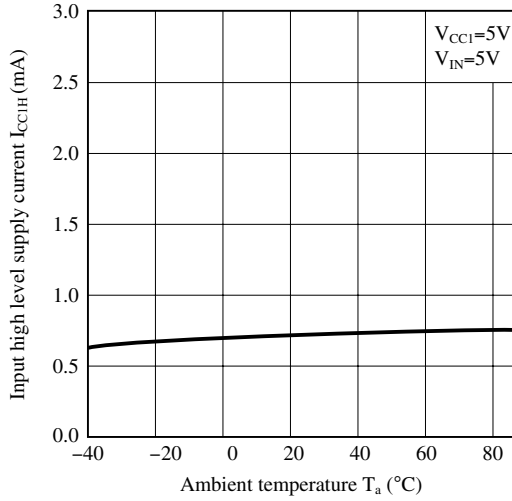
**Fig.3 Output Voltage vs. Input Voltage**



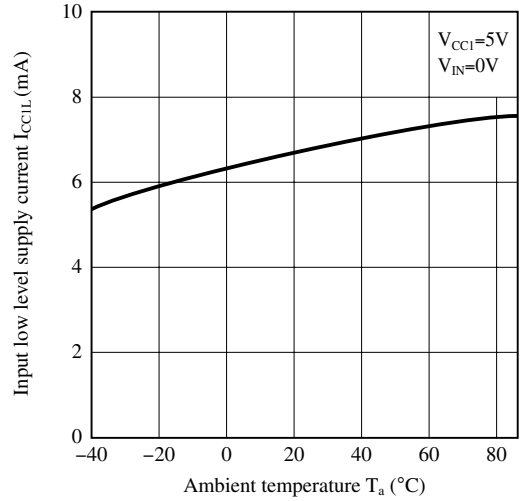
**Fig.4 Input Threshold Voltage vs. Input Supply Voltage**



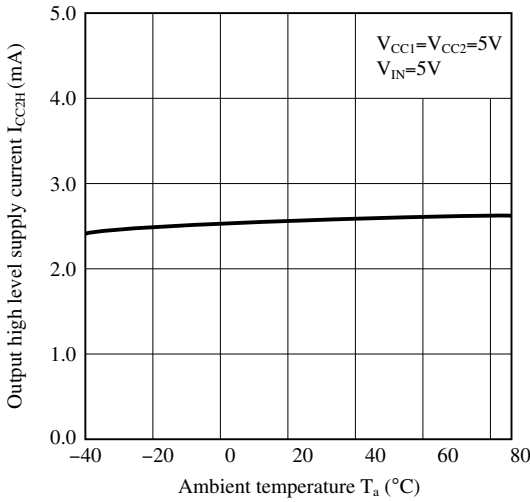
**Fig.5 Input High Level Supply Current vs. Ambient Temperature**



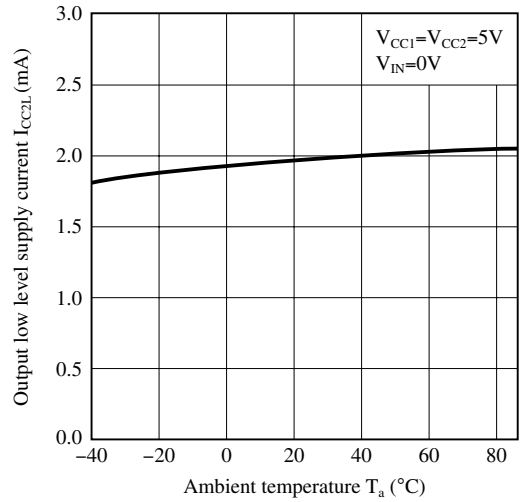
**Fig.6 Input Low Level Supply Current vs. Ambient Temperature**



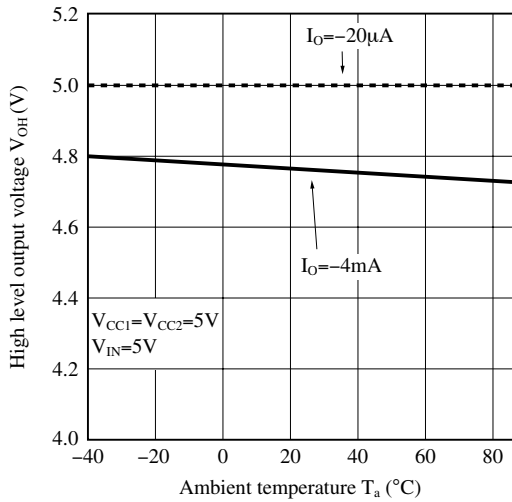
**Fig.7 Output High Level Supply Current vs. Ambient Temperature**



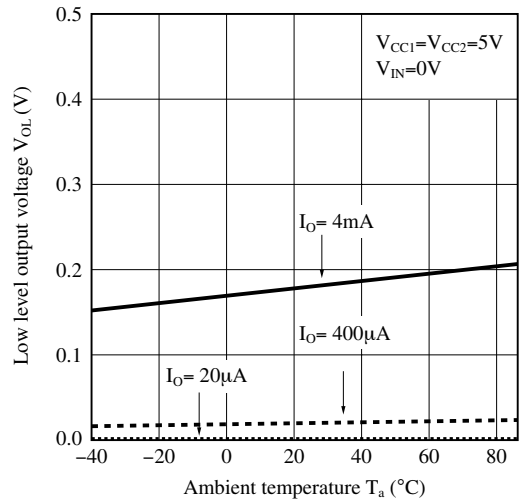
**Fig.8 Output Low Level Supply Current vs. Ambient Temperature**



**Fig.9 High Level Output Voltage vs. Ambient Temperature**

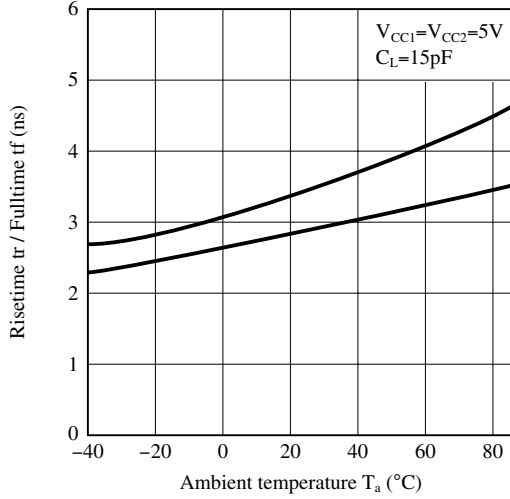


**Fig.10 Low Level Output Voltage vs. Ambient Temperature**

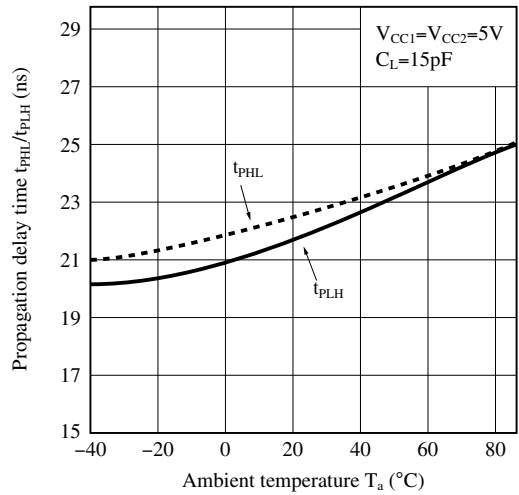




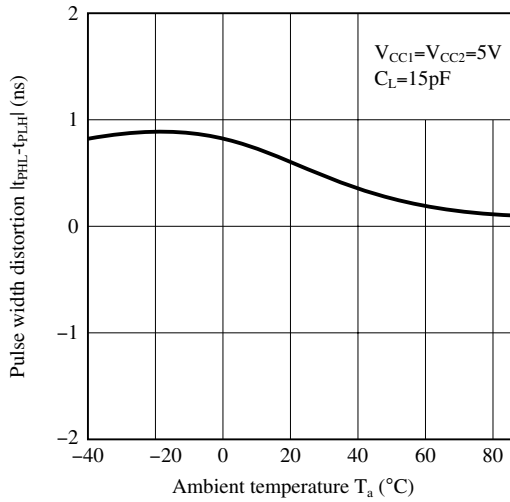
**Fig.11 Rise Time/Fall Time vs. Ambient Temperature**



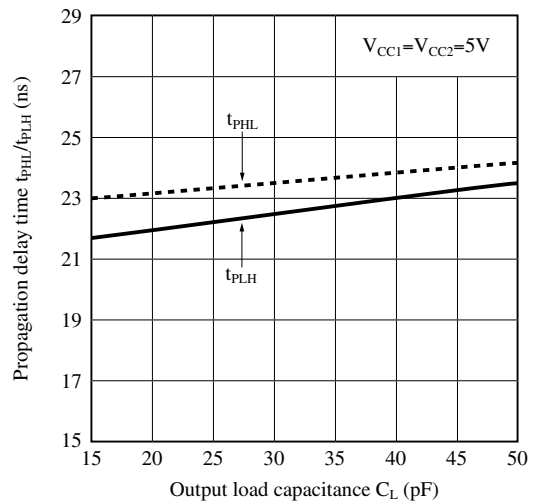
**Fig.12 Propagation Delay Time vs. Ambient Temperature**



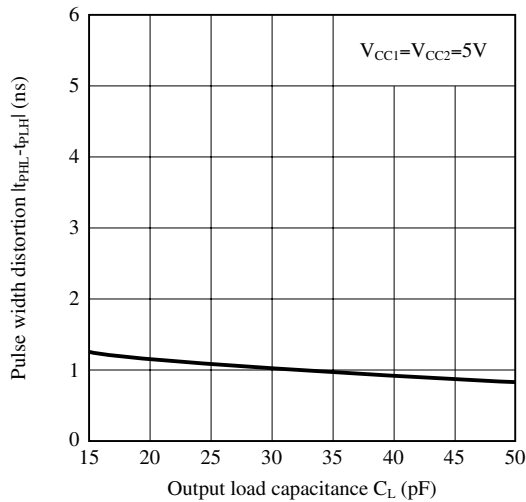
**Fig.13 Pulse Width Distortion vs. Ambient Temperature**



**Fig.14 Propagation Delay Time vs. Output Load Capacitance**



**Fig.15 Pulse Width Distortion vs. Ambient Temperature**



Remarks : Please be aware that all data in the graph are just for reference and not for guarantee.

## ■ Design Considerations

### ● Recommended operating conditions

Parameter	Symbol	MIN.	TYP.	MAX.	Unit
Supply voltage	$V_{CC1}$	4.5	–	5.5	V
Supply voltage	$V_{CC2}$	4.5	–	5.5	V
Low level input voltage	$V_{IL}$	0	–	0.8	V
High level input voltage	$V_{IH}$	2.0	–	$V_{CC1}$	V
Operating temperature	$T_{opr}$	–40	–	+70	°C

### ● Notes about static electricity

Transistor of detector side in CMOS configuration may be damaged by static electricity due to its minute design.

When handling these devices, general countermeasure against static electricity should be taken to avoid breakdown of devices or degradation of characteristics.

### ● Design guide

In order to stabilize power supply line, we should certainly recommend to connect a by-pass capacitor of 0.01 $\mu$ F or more between  $V_{CC1}$ -GND and  $V_{CC2}$ -GND near the device.

The detector which is used in this device, has parasitic diode between each pins and GND.

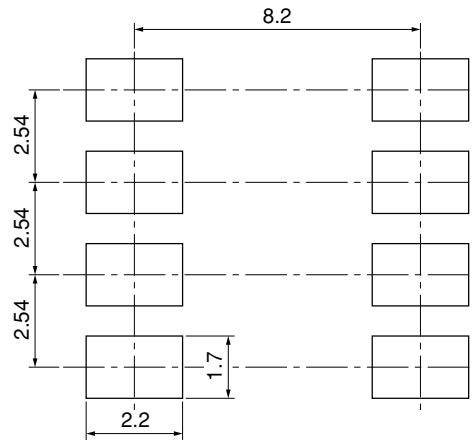
There are cases that miss operation or destruction possibly may be occurred if electric potential of any pin becomes below GND level even for instant.

Therefore it shall be recommended to design the circuit that electric potential of any pin does not become below GND level.

This product is not designed against irradiation and incorporates non-coherent LED.

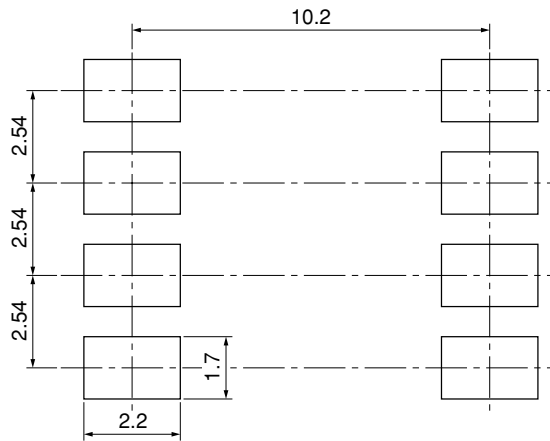
● Recommended Foot Print (reference)

SMT Gullwing Lead-form



(Unit : mm)

Wide SMT Gullwing Lead-form



(Unit : mm)

☆ For additional design assistance, please review our corresponding Optoelectronic Application Notes.

## ■ Manufacturing Guidelines

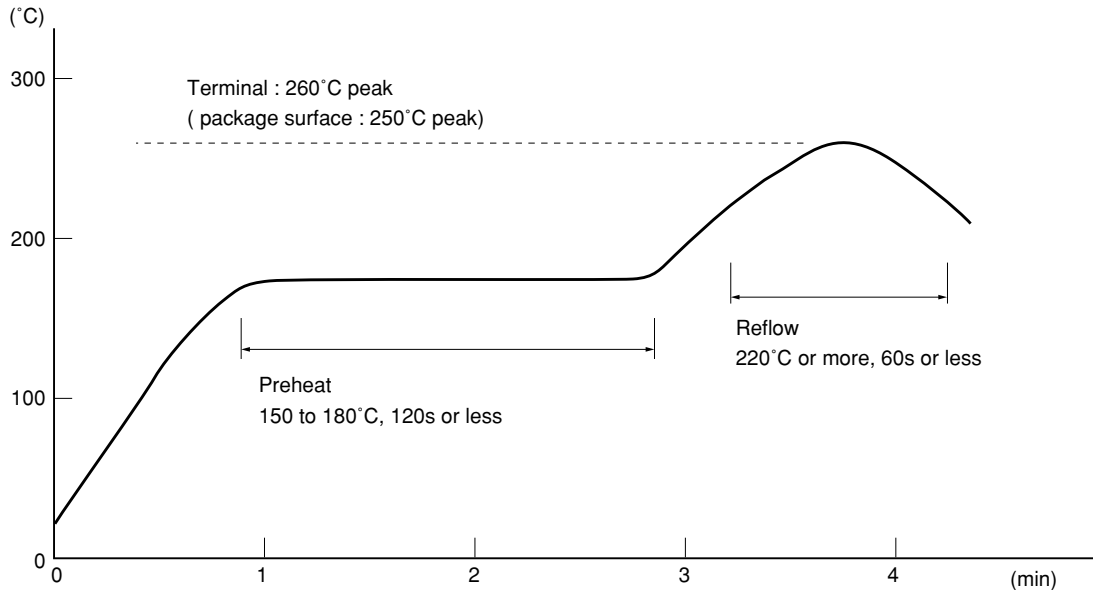
### ● Soldering Method

#### Reflow Soldering:

Reflow soldering should follow the temperature profile shown below.

Soldering should not exceed the curve of temperature profile and time.

Please don't solder more than twice.



#### Flow Soldering :

Due to SHARP's double transfer mold construction submersion in flow solder bath is allowed under the below listed guidelines.

Flow soldering should be completed below 270°C and within 10s.

Preheating is within the bounds of 100 to 150°C and 30 to 80s.

Please don't solder more than twice.

#### Hand soldering

Hand soldering should be completed within 3s when the point of solder iron is below 400°C.

Please don't solder more than twice.

#### Other notices

Please test the soldering method in actual condition and make sure the soldering works fine, since the impact on the junction between the device and PCB varies depending on the tooling and soldering conditions.

**● Cleaning instructions****Solvent cleaning:**

Solvent temperature should be 45°C or below Immersion time should be 3minutes or less

**Ultrasonic cleaning:**

The impact on the device varies depending on the size of the cleaning bath, ultrasonic output, cleaning time, size of PCB and mounting method of the device.

Therefore, please make sure the device withstands the ultrasonic cleaning in actual conditions in advance of mass production.

**Recommended solvent materials:**

Ethyl alcohol, Methyl alcohol and Isopropyl alcohol

In case the other type of solvent materials are intended to be used, please make sure they work fine in actual using conditions since some materials may erode the packaging resin.

**● Presence of ODC**

This product shall not contain the following materials.

And they are not used in the production process for this product.

Regulation substances : CFCs, Halon, Carbon tetrachloride, 1.1.1-Trichloroethane (Methylchloroform)

Specific brominated flame retardants such as the PBB and PBDE are not used in this product at all.

This product shall not contain the following materials banned in the RoHS Directive.

- Lead, Mercury, Cadmium, Hexavalent chromium, Polybrominated biphenyls (PBB), Polybrominated diphenyl ethers (PBDE).

■ Package specification

● Sleeve package

1. Through-Hole or SMT Gullwing

Package materials

Sleeve : HIPS (with anti-static material)

Stopper : Styrene-Elastomer

Package method

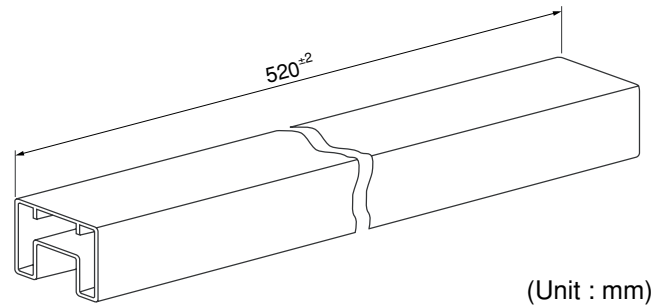
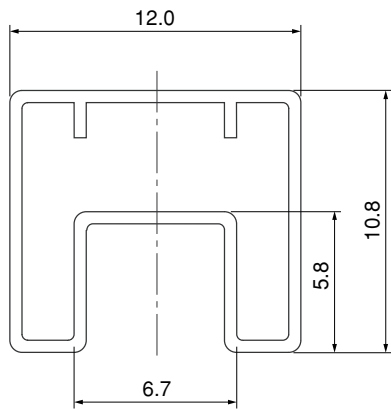
MAX. 50 pcs. of products shall be packaged in a sleeve.

Both ends shall be closed by tabbed and tabless stoppers.

The product shall be arranged in the sleeve with its primary side mark on the tabless stopper side.

MAX. 20 sleeves in one case.

Sleeve outline dimensions



2. Wide SMT Gullwing

Package materials

Sleeve : HIPS (with anti-static material)

Stopper : Styrene-Elastomer

Package method

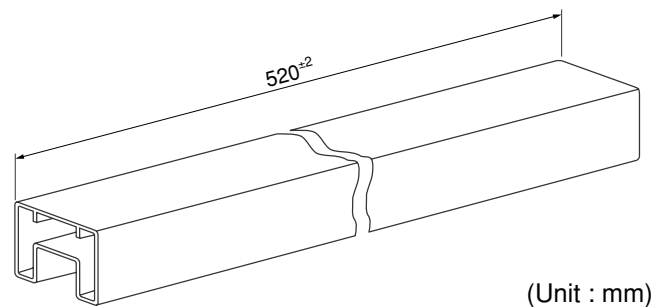
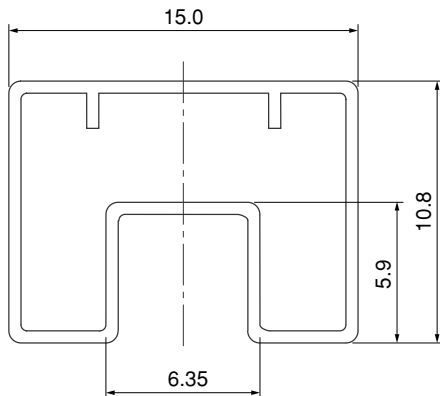
MAX. 50 pcs. of products shall be packaged in a sleeve.

Both ends shall be closed by tabbed and tabless stoppers.

The product shall be arranged in the sleeve with its primary side mark on the tabless stopper side.

MAX. 20 sleeves in one case.

Sleeve outline dimensions



## ■ Important Notices

· The circuit application examples in this publication are provided to explain representative applications of SHARP devices and are not intended to guarantee any circuit design or license any intellectual property rights. SHARP takes no responsibility for any problems related to any intellectual property right of a third party resulting from the use of SHARP's devices.

· Contact SHARP in order to obtain the latest device specification sheets before using any SHARP device. SHARP reserves the right to make changes in the specifications, characteristics, data, materials, structure, and other contents described herein at any time without notice in order to improve design or reliability. Manufacturing locations are also subject to change without notice.

· Observe the following points when using any devices in this publication. SHARP takes no responsibility for damage caused by improper use of the devices which does not meet the conditions and absolute maximum ratings to be used specified in the relevant specification sheet nor meet the following conditions:

(i) The devices in this publication are designed for use in general electronic equipment designs such as:

- Personal computers
- Office automation equipment
- Telecommunication equipment [terminal]
- Test and measurement equipment
- Industrial control
- Audio visual equipment
- Consumer electronics

(ii) Measures such as fail-safe function and redundant design should be taken to ensure reliability and safety when SHARP devices are used for or in connection

with equipment that requires higher reliability such as:

- Transportation control and safety equipment (i.e., aircraft, trains, automobiles, etc.)
- Traffic signals
- Gas leakage sensor breakers
- Alarm equipment
- Various safety devices, etc.

(iii) SHARP devices shall not be used for or in connection with equipment that requires an extremely high level of reliability and safety such as:

- Space applications
- Telecommunication equipment [trunk lines]
- Nuclear power control equipment
- Medical and other life support equipment (e.g., scuba).

· If the SHARP devices listed in this publication fall within the scope of strategic products described in the Foreign Exchange and Foreign Trade Law of Japan, it is necessary to obtain approval to export such SHARP devices.

· This publication is the proprietary product of SHARP and is copyrighted, with all rights reserved. Under the copyright laws, no part of this publication may be reproduced or transmitted in any form or by any means, electronic or mechanical, for any purpose, in whole or in part, without the express written permission of SHARP. Express written permission is also required before any use of this publication may be made by a third party.

· Contact and consult with a SHARP representative if there are any questions about the contents of this publication.

# Mouser Electronics

Authorized Distributor

Click to View Pricing, Inventory, Delivery & Lifecycle Information:

[Sharp Microelectronics:](#)

[PC912L0NSZ0F](#)