

8 7 6 5 4 3 2 1

NOTES:

1. MOUNTING: Mounts in a $\phi .312 \pm .002$ ($\phi 7.92\text{mm} \pm 0.051$) panel hole on .500 (12.7mm) centers. Panel thickness .031 (.8mm) to .125 (3.18mm). Panel hole shall be deburred, but not chamfered.
2. ASSEMBLY: Insert Litepipe through the panel hole, slide lock washer onto lens barrel on litepipe and twist on retaining ring. Slide PCB into position aligning LED with the end of the Litepipe unit.
3. MATERIAL: Litepipe - Acrylic (Clear optical grade) UL 94-HB
 Lens - Polycarbonate UL 94-V2
 Seal - EPDM
 Lock washer - FH Steel, Nickel Plate
 Retaining Nut - Thermoplastic (white) UL 94-V0
4. Meets NEMA 6P/IP 67 standards
5. U.S. & Foreign Pat. Issued

REVISIONS					
ECN #	REV.	DESCRIPTION	DATE	INITIALS	CHK'D
	001	REVISED PER ECR 111009AZ01	8/18/10	KH	DZ
	002	MODIFIED GENERAL TOLERANCE .XX	11/29/11	KH	AZ

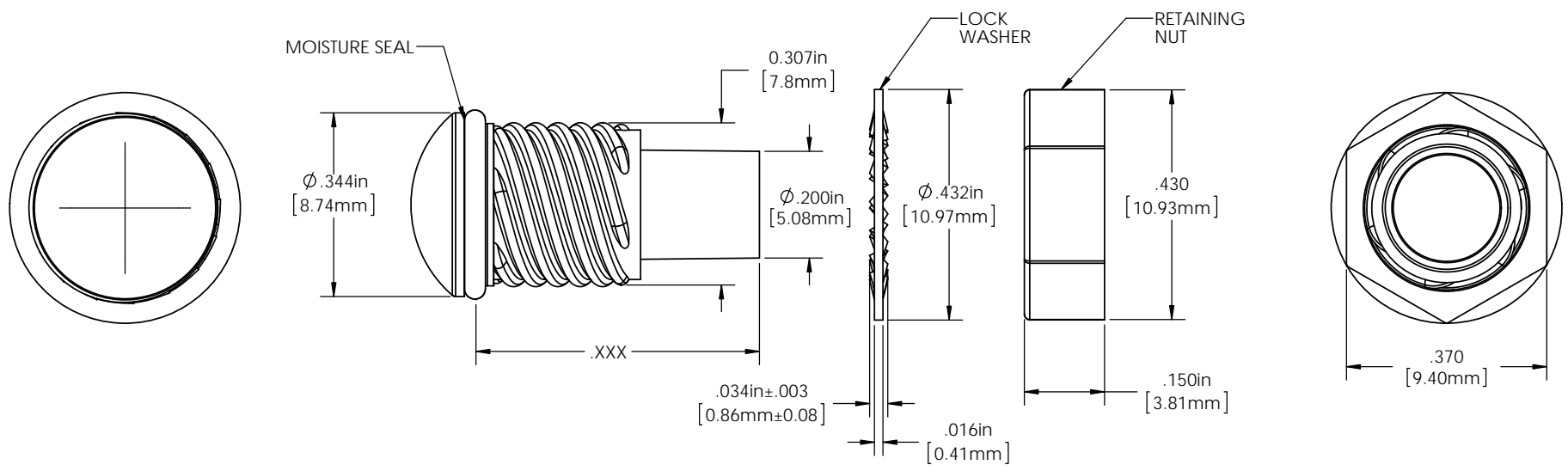
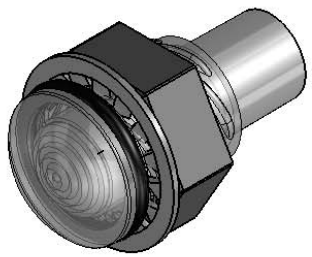

ORDERING CODE: **LCS XXX XXX**

LITEPIPE	
XXX =	LENGTH
032	.320"
052	.520"
072	.720"
092	.92"
112	1.12"
132	1.32"

LENS	
XXX =	COLOR
RTP	RED TRANSPARENT
ATP	AMBER TRANSPARENT
GTP	GREEN TRANSPARENT
BTP	BLUE TRANSPARENT
YTP	YELLOW TRANSPARENT
CTP	CLEAR TRANSPARENT

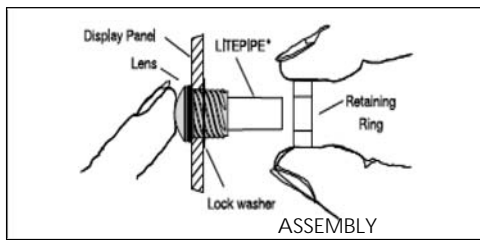

APPROVAL		DATE
DRAWN KHOWARD		8/18/10
CHECKED DPZ		8/19/10
MATERIAL		
SEE NOTES		
FINISH		
SEE NOTES		
DO NOT SCALE DRAWING		

VCC OPTOELECTRONICS
 190 BOSSTICK BLVD. SUITE 101 SAN MARCOS, CA 92069 U.S.A.
 PHONE: (760) 560-1300. FAX: (760) 560-1301 EMAIL: vccsales@vcc3ite.com

TITLE: 5MM THREADED MOISTURE SEALED LITEPIPE

SIZE	DWG. NO.	REV
B	LCS XXX XXX	002

SCALE: 5:1 SHEET 1 OF 1

CUSTOM LENGTHS AVAILABLE UPON REQUEST

8 7 6 5 4 3 2 1

Mouser Electronics

Authorized Distributor

Click to View Pricing, Inventory, Delivery & Lifecycle Information:

VCC:

[LCS_032_ATP](#) [LCS_032_BTP](#) [LCS_032_CTP](#) [LCS_032_GTP](#) [LCS_032_YTP](#) [LCS_052_ATP](#) [LCS_132_BTP](#)
[LCS_132_CTP](#) [LCS_132_GTP](#) [LCS_132_RTP](#) [LCS_132_YTP](#) [LCS_112_BTP](#) [LCS_112_CTP](#) [LCS_112_GTP](#)
[LCS_112_RTP](#) [LCS_112_YTP](#) [LCS_132_ATP](#) [LCS_092_BTP](#) [LCS_092_CTP](#) [LCS_092_GTP](#) [LCS_092_RTP](#)
[LCS_092_YTP](#) [LCS_112_ATP](#) [LCS_072_BTP](#) [LCS_072_CTP](#) [LCS_072_GTP](#) [LCS_072_RTP](#) [LCS_072_YTP](#)
[LCS_092_ATP](#) [LCS_052_BTP](#) [LCS_052_CTP](#) [LCS_052_GTP](#) [LCS_052_RTP](#) [LCS_052_YTP](#) [LCS_072_ATP](#)